

**SILICON NPN TRANSISTOR**

- SGS-THOMSON PREFERRED SALESTYPE
- NPN TRANSISTOR
- FAST SWITCHING SPEED
- LOW COLLECTOR EMITTER SATURATION

**APPLICATIONS**

- GENERAL PURPOSE SWITCHING

**DESCRIPTION**

The BUY49S is a silicon epitaxial planar NPN transistor in jedec TO-39 package. It is used in high-current switching applications up to 3 A.

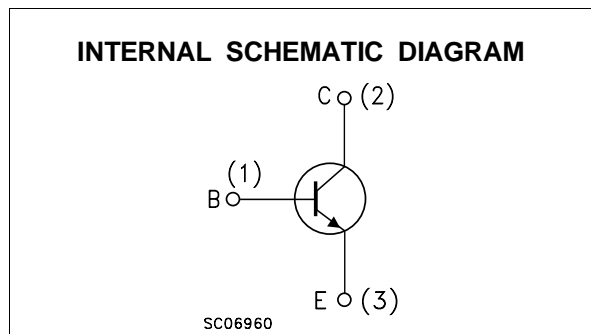
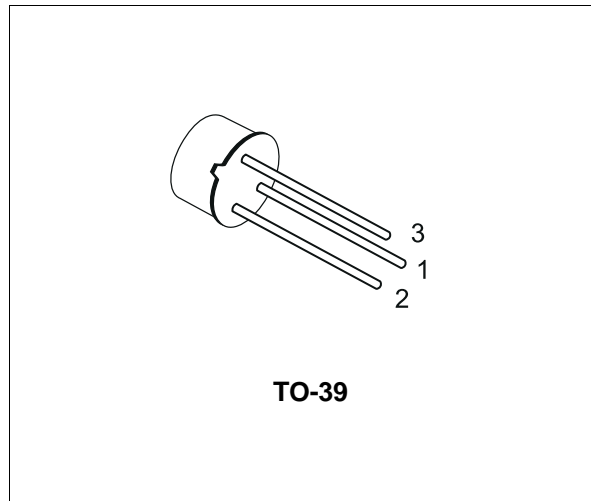

**ABSOLUTE MAXIMUM RATINGS**

Symbol	Parameter	Value	Unit
$V_{CBO}$	Collector-Base Voltage ( $I_E = 0$ )	250	V
$V_{CEO}$	Collector-Emitter Voltage ( $I_B = 0$ )	200	V
$V_{EBO}$	Emitter-Base Voltage ( $I_C = 0$ )	6	V
$I_C$	Collector Current	3	A
$I_{CM}$	Collector Peak Current	5	A
$P_{tot}$	Total Power Dissipation at $T_{amb} \leq 25\text{ }^\circ\text{C}$	10	W
$T_{stg}$	Storage Temperature	- 65 to 200	$^\circ\text{C}$
$T_j$	Max Operating Junction Temperature	200	$^\circ\text{C}$

## BUY49S

### THERMAL DATA

R <sub>thj-case</sub>	Thermal Resistance Junction-case	Max	15	°C/W
R <sub>thj-amb</sub>	Thermal Resistance Junction-case-ambient	Max	175	°C/W

### ELECTRICAL CHARACTERISTICS (T<sub>case</sub> = 25 °C unless otherwise specified)

Symbol	Parameter	Test Conditions	Min.	Typ.	Max.	Unit
I <sub>CBO</sub>	Collector Cut-off Current (I <sub>E</sub> = 0)	V <sub>CB</sub> = 200 V V <sub>CB</sub> = 200 V      T <sub>case</sub> = 150 °C			0.1 50	μA μA
V <sub>(BR)CBO</sub> *	Collector-Base Breakdown Voltage (I <sub>E</sub> = 0)	I <sub>C</sub> = 100 μA	250			V
V <sub>CEO(sus)</sub> *	Collector-Emitter Sustaining Voltage (I <sub>B</sub> = 0)	I <sub>C</sub> = 20 mA	200			V
V <sub>EBO</sub> *	Emitter-base Voltage (I <sub>C</sub> = 0)	I <sub>E</sub> = 1 mA	6			V
V <sub>CE(sat)</sub> *	Collector-Emitter Saturation Voltage	I <sub>C</sub> = 0.5 A      I <sub>B</sub> = 50 mA			0.2	V
V <sub>BE(sat)</sub> *	Collector-Emitter Saturation Voltage	I <sub>C</sub> = 0.5 A      I <sub>B</sub> = 50 mA			1.1	V
h <sub>FE</sub> *	DC Current Gain	I <sub>C</sub> = 20 mA      V <sub>CE</sub> = 5 V I <sub>C</sub> = 0.5 A      V <sub>CE</sub> = 5 V I <sub>C</sub> = 20 mA      V <sub>CE</sub> = 2 V T <sub>case</sub> = - 55 °C	40 40 16	80		
f <sub>T</sub>	Transistor Frequency	I <sub>C</sub> = 100 mA      V <sub>CE</sub> = 10 V	50			MHz
C <sub>CBO</sub>	Collector-base Capacitance	I <sub>E</sub> = 0      V <sub>CB</sub> = 10 V f = 1 MHz			30	pF
t <sub>on</sub>	Turn-on Time	I <sub>C</sub> = 0.5 A      V <sub>CC</sub> = 20 V			0.3	μs
t <sub>off</sub>	Turn-off Time	I <sub>B1</sub> = - I <sub>B2</sub> = 50 mA			1	μs
I <sub>s/b</sub> **	Second Breakdown Collector Current	V <sub>CE</sub> = 50 V	0.2			A

\* Pulsed: Pulse duration = 300 μs, duty cycle = 1.5 %

\*\* Pulsed: 1 s, non repetitive pulse.

**TO-39 MECHANICAL DATA**

DIM.	mm			inch		
	MIN.	TYP.	MAX.	MIN.	TYP.	MAX.
A	12.7			0.500		
B			0.49			0.019
D			6.6			0.260
E			8.5			0.334
F			9.4			0.370
G	5.08			0.200		
H			1.2			0.047
I			0.9			0.035
L	45° (typ.)					

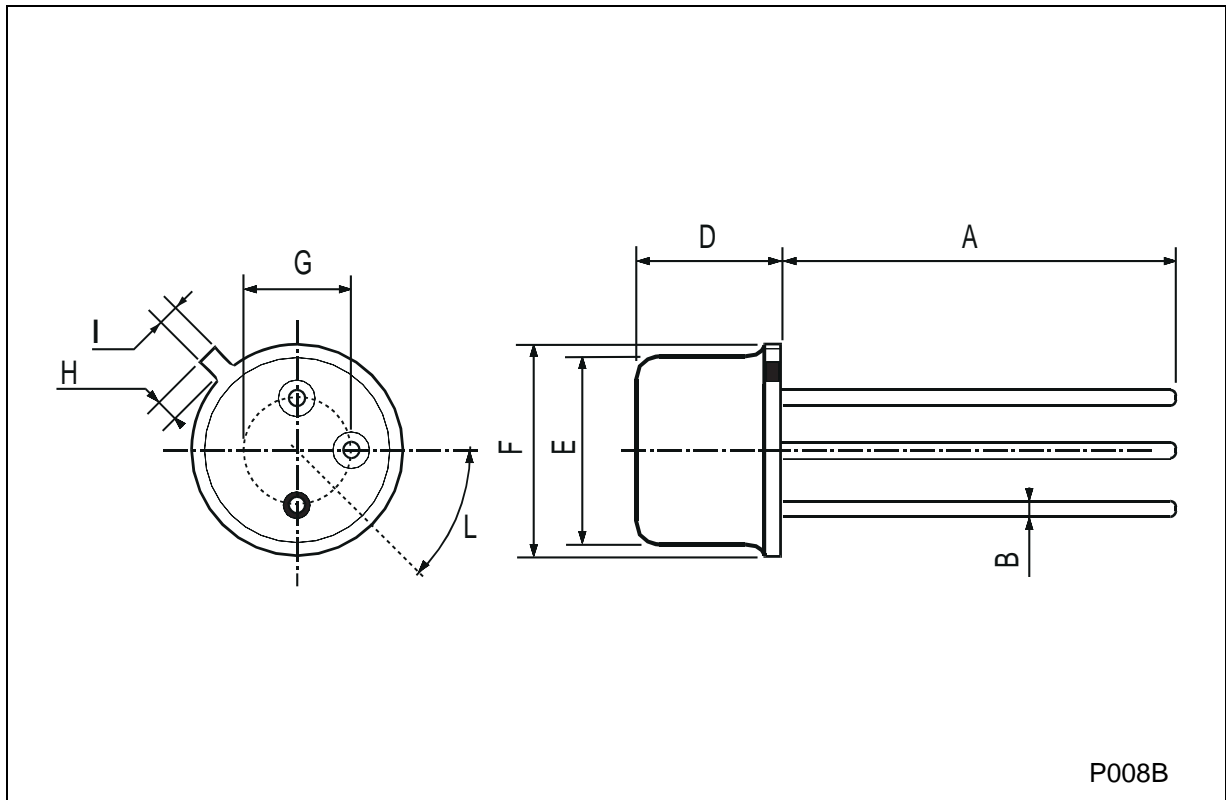

P008B

Information furnished is believed to be accurate and reliable. However, SGS-THOMSON Microelectronics assumes no responsibility for the consequences of use of such information nor for any infringement of patents or other rights of third parties which may result from its use. No license is granted by implication or otherwise under any patent or patent rights of SGS-THOMSON Microelectronics. Specifications mentioned in this publication are subject to change without notice. This publication supersedes and replaces all information previously supplied. SGS-THOMSON Microelectronics products are not authorized for use as critical components in life support devices or systems without express written approval of SGS-THOMSON Microelectronics.

© 1997 SGS-THOMSON Microelectronics - Printed in Italy - All Rights Reserved

SGS-THOMSON Microelectronics GROUP OF COMPANIES  
Australia - Brazil - Canada - China - France - Germany - Hong Kong - Italy - Japan - Korea - Malaysia - Malta - Morocco - The Netherlands -  
Singapore - Spain - Sweden - Switzerland - Taiwan - Thailand - United Kingdom - U.S.A  
...



LittleDiode supplies new, hard to find or obsolete electronic components and semiconductors all over the world.

With over two million different components listed you are sure to find the part you need.

Feel free to visit us today at our online store:

[LittleDiode.com](http://LittleDiode.com)

Looking forward to providing you with the best possible service.