



Quad 8-Bit CMOS D/A Converter with Internal 10 V Reference

DAC-8426

1.1 Scope.

This specification covers the detail requirement for a quad 8-bit CMOS digital-to-analog converter with output voltage amplifiers and internal 10 V voltage reference. The internal latches provide direct interface for most microprocessors. The DAC-8426 operates with either a dual or single power supply.

It is highly recommended that this data sheet be used as a baseline for new military or aerospace specification control drawings.

1.2 Part Number.

The complete part numbers per Table 1 of this specification is as follows:

Device	Part Number	Package
-1	DAC-8426AR/883	R
-2	DAC-8426BR/883	R

1.2.3 Case Outline.

Letter	Case Outline (Lead Finish per MIL-M-38510)
R	20-Lead Ceramic Dual-in-Line Package (Cerdip)

1.3 Absolute Maximum Ratings. ($T_A = +25^\circ\text{C}$ unless otherwise noted)

V_{DD} to AGND or DGND	-0.3 V, +17 V
V_{SS} to AGND or DGND	-7 V, V_{DD}
V_{DD} to V_{SS}	-0.3 V, +24 V
AGND to DGND	-0.3 V, +5 V
Digital Input Voltage to DGND	-0.3 V, V_{DD}
V_{REFOUT} to AGND	-0.3 V, V_{DD}
V_{OUT} to AGND	V_{SS} , V_{DD}
Power Dissipation to $+75^\circ\text{C}$	500 mW
Derate above 75°C by	6.4 mW/ $^\circ\text{C}$
Operating Temperature Range	-55°C to $+125^\circ\text{C}$
Junction Temperature Range (T_J)	-65°C to $+150^\circ\text{C}$
Storage Temperature Range	-65°C to $+150^\circ\text{C}$
Lead Temperature (Soldering 60 sec)	$+300^\circ\text{C}$

1.5 Thermal Characteristics.

Thermal Resistance θ_{JC}	$= 7^\circ\text{C}/\text{W}$
θ_{JA}	$= 70^\circ\text{C}/\text{W}$ max

REV. A

Information furnished by Analog Devices is believed to be accurate and reliable. However, no responsibility is assumed by Analog Devices for its use, nor for any infringements of patents or other rights of third parties which may result from its use. No license is granted by implication or otherwise under any patent or patent rights of Analog Devices.

One Technology Way, P.O. Box 9106, Norwood, MA 02062-9106, U.S.A.
Tel: 617/329-4700 Fax: 617/326-8703 Twx: 710/394-6577
Telex: 924491 Cable: ANALOG NORWOODMASS

DAC-8426—SPECIFICATIONS

Table 1.

Test	Symbol	Device Types	Limits		Group A Subgroups	Conditions ¹	Units
			Min	Max			
Resolution	N	All	8		1, 2, 3	T _A = +25°C, -55°C & +125°C	Bits
Total Unadjusted Error	TUE	All	-1	±1	1, 2, 3	Includes Reference ² T _A = +25°C, -55°C & +125°C	LSB
			-2	±2	1, 2, 3		
Relative Accuracy	INL	All	-1	±1/2	1, 2, 3	T _A = +25°C, -55°C & +125°C	LSB
			-2	±1	1, 2, 3		
Differential Nonlinearity	DNL	All		±1	1, 2, 3	Note 3; T _A = +25°C, -55°C & +125°C	LSB
Zero Scale Error	V _{ZSE}	All		20	1, 2, 3	V _{SS} = -5 V; T _A = +25°C, -55°C & +125°C	mV
Reference Output Voltage	V _{REFOUT}	All	9.96	10.02	1, 2, 3	No Load; T _A = +25°C, -55°C & +125°C	V
			-2	9.92			
Reference Load Regulation	LD _{REG}	All		0.1	1, 2, 3	ΔI _L = 10 mA; T _A = +25°C, -55°C & +125°C	%/mA
Reference Line Regulation	LN _{REG}	All		0.04	1, 2, 3	ΔV _{DD} = ±10%; T _A = +25°C, -55°C & +125°C	%/mA
Reference Output Current	I _{REFOUT}	All	5		1, 2, 3	ΔV _{REFOUT} < 40 mV; T _A = +25°C, -55°C & +125°C	mA
Logic Input "0"	V _{INL}	All		0.8	1, 2, 3	T _A = +25°C, -55°C & +125°C	V
Logic Input "1"	V _{INH}	All	2.4		1, 2, 3	T _A = +25°C, -55°C & +125°C	V
Logic Input Current	I _{IN}	All		10	1, 2, 3	V _{IN} = 0 V or V _{DD} ; T _A = +25°C, -55°C & +125°C	μA
Positive Supply Current ³	I _{DD}	All		14	1, 2, 3	T _A = +25°C, -55°C & +125°C	mA
Negative Supply Current ³	I _{SS}	All		10	1, 2, 3	Dual Supply, V _{SS} = -5 V; T _A = +25°C, -55°C & +125°C	mA
Power Supply Sensitivity	PSS	All		0.01	1, 2, 3	ΔV _{DD} = ±10%; T _A = +25°C, -55°C & +125°C	%/%
Output Source Current	I _{OUT}	All	10		1, 2, 3	Digital Inputs All Ones; T _A = +25°C, -55°C & +125°C	mA
Output Sink Current	I _{OUT-}	All	0.35		1, 2, 3	Digital Inputs All Zeros	mA
V _{OUT} Settling Time (Positive or Negative)	t _S	All		5	9	T _O ±1/2 LSB; T _A = +25°C	μs
Address to Write Setup Time	t _{AS}	All	0		9, 10, 11	T _A = +25°C, -55°C & +125°C	ns
Address to Write Hold Time	t _{AH}	All	0		9, 10, 11	T _A = +25°C, -55°C & +125°C	ns
Data Valid to Write Setup Time	t _{DS}	All	70		9, 10, 11	T _A = +25°C, -55°C & +125°C	ns
Data Valid to Write Hold Time	t _{DH}	All	10		9, 10, 11	T _A = +25°C, -55°C & +125°C	ns
Write Pulse Width	t _{WR}	All	50		9, 10, 11	T _A = +25°C, -55°C & +125°C	ns
Minimum Load Resistance	R _{L(MIN)}	All	2		1, 2, 3	Digital Inputs All Ones; T _A = +25°C, -55°C & +125°C	kΩ
V _{OUT} Slew Rate	SR	All	2.5		7	T _A = +25°C	V/μs

NOTES

¹V_{DD} = +15 V ± 10%, AGND = 0 V, DGND = 0 V, V_{SS} = 0 V unless otherwise specified.

²Includes full-scale error, relative accuracy, and zero code error.

³Digital inputs V_{IN} = V_{INL} or V_{INH}; V_{OUT} and V_{REFOUT} unloaded.

Table 2. Electrical Test Requirements for Class B Devices

MIL-STD-883 Test Requirements	Subgroups (See Table 3)
Interim Electrical Parameters (Pre Burn-In)	1
Final Electrical Test Parameters	1,* 2, 3
Group A Test Requirements	1, 2, 3, 7, 9, 10, 11

NOTE

*PDA applies to Subgroup 1 only. No other subgroups are included in PDA.

Table 3. Control Table

Logic Control			DAC-8426
WR	A1	A0	Operation
H	X	X	No Operation Device Not Selected
L	L	L	DAC A Transparent
\overline{L}	L	L	DAC A Latched
L	L	H	DAC B Transparent
\overline{L}	L	H	DAC B Latched
L	H	L	DAC C Transparent
\overline{L}	H	L	DAC C Latched
L	H	H	DAC D Transparent
\overline{L}	H	H	DAC D Latched

L = Low State, H = High State, X = Don't Care.

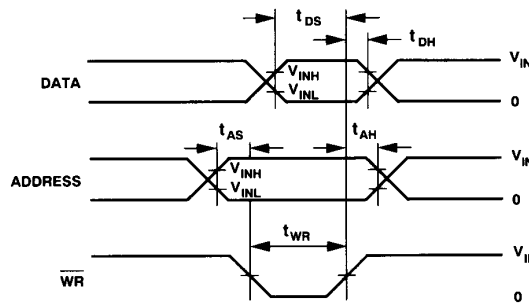

NOTES:

1. ALL INPUT SIGNAL RISE AND FALL TIMES ARE MEASURED FROM THE 10% TO 90% OF V_{DD} ($t_r = t_f = 20ns$ OVER THE V_{DD} RANGE)
2. TIMING REFERENCE LEVEL IS FROM $\frac{V_{INH} + V_{INL}}{2}$
3. $V_{IN} = 5V$

Write Timing Diagram

DAC-8426

3.2.1 Functional Block Diagram and Terminal Assignments.

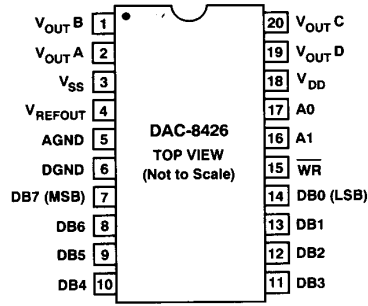
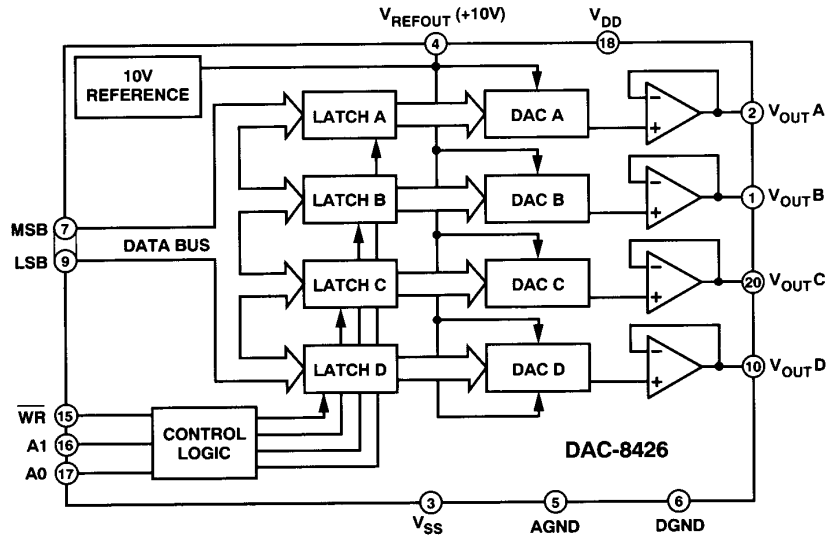

3.2.4 Microcircuit Technology Group.

This microcircuit is covered by technology group 80.

4.2.1 Life Test/Burn-In Circuit.

Steady state life test is per MIL-STD-883 Method 1005. Burn-in is per MIL-STD-883 Method 1015 test condition (B).

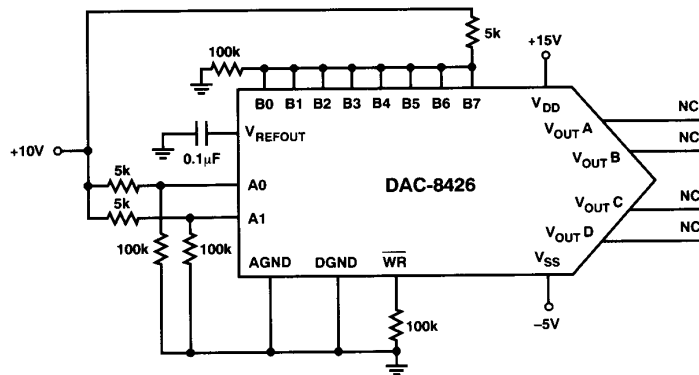

20-Lead Ceramic DIP
(R Suffix)

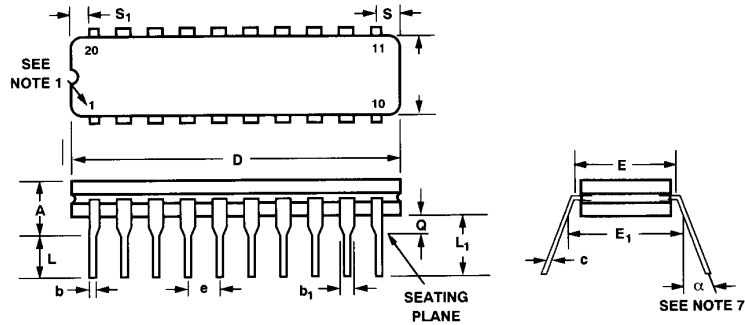

20-Lead Ceramic DIP
(R Suffix)

SYMBOL	INCHES		MILLIMETERS		NOTES
	MIN	MAX	MIN	MAX	
A		0.200		5.08	
b	0.014	0.023	0.36	0.58	
b ₁	0.030	0.070	0.76	1.78	2
c	0.008	0.015	0.20	0.38	
D		1.060		26.92	4
E	0.220	0.310	5.59	7.87	4
E ₁	0.290	0.320	7.37	8.13	7
e	0.100 BSC		2.54 BSC		5
L	0.125	0.200	3.18	5.08	
L ₁	0.150		3.81		
Q	0.015	0.060	0.38	1.52	3
S		0.080		2.03	6
S ₁	0.005		0.13		6
α	0°	15°	0°	15°	

NOTES

1. Index area; a notch or a lead one identification mark is located adjacent to lead one.
2. The minimum limit for dimension b₁ may be 0.023" (0.58 mm) for all four corner leads only.
3. Dimension Q shall be measured from the seating plane to the base plane.
4. This dimension allows for off-center lid, meniscus and glass overrun.
5. The basic lead spacing is 0.100" (2.54 mm) between centerlines.
6. Applies to all four corners.
7. Leads center when α is 0°. E₁ shall be measured at the centerline of the leads.



LittleDiode supplies new, hard to find or obsolete electronic components and semiconductors all over the world.

With over two million different components listed you are sure to find the part you need.

Feel free to visit us today at our online store:

LittleDiode.com

Looking forward to providing you with the best possible service.