

2540

QUAD DARLINGTON POWER DRIVER

UDN2540B

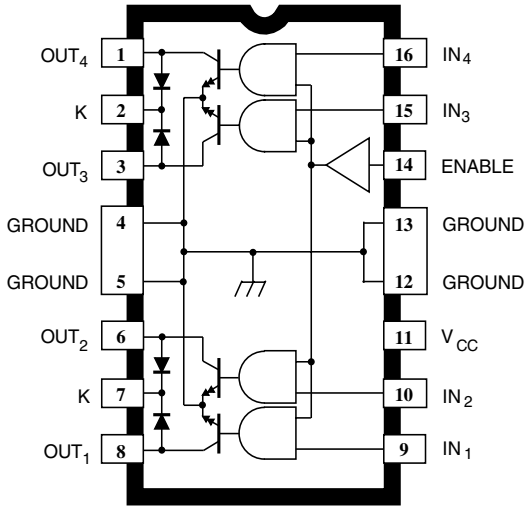

Dwg. PP-017-2

ABSOLUTE MAXIMUM RATINGS

at $T_A = 25^\circ\text{C}$

Output Voltage, V_{OUT}	50 V
Output Current, I_{OUT} (peak)	2.5 A
(continuous)	1.8 A
Logic Supply Voltage, V_{CC}	7.0 V
Input Voltage, V_{IN}	7.0 V
Package Power Dissipation, P_D	See Graph
Operating Temperature Range, T_A	-20°C to +85°C
Storage Temperature Range, T_S	-55°C to +150°C

Combining AND logic gates and inverting high-current bipolar outputs, the UDN2540B and A2540SLB quad Darlington power drivers provide interface between low-level signal-processing circuits and power loads totaling 360 W. Each of the four independent outputs can sink up to 1.8 A in the on state with peak inrush currents to 2.5 A. The four power outputs are each comprised of an open-collector Darlington driver and an internal flyback/clamp diode for switching inductive loads. They feature a minimum breakdown and sustaining voltage of 50 V. The logic inputs are compatible with TTL and 5 V CMOS logic systems.

Typical applications include print heads, relays, solenoids, and dc stepping motors. These drivers can also be used to drive high-current incandescent lamps, LEDs, and heaters. A similar device, specifically intended for driving a unipolar stepper motor in the two-phase drive format, is the UDN2544B.

The UDN2540B is supplied in a 16-pin batwing power DIP; the A2540SLB is supplied in a 20-lead batwing power SOIC for surface-mount applications. The batwing construction provides for maximum package power dissipation in a standard construction. At 25°C, and with only 1 sq. in. of copper foil at the ground tabs, either package is capable of safely dissipating more than 2 W.

FEATURES

- 1.8 A Continuous Output Current
- Output Voltage to 50 V
- TTL and 5 V CMOS Compatible Inputs
- Efficient Input/Output Pinning
- Integral Transient-Suppression Diodes
- Replaces L6221A and L6221CD

Always order by complete part number:

Part Number	Package
UDN2540B	16-pin batwing DIP
A2540SLB	20-lead batwing SOIC

2540 QUAD DARLINGTON POWER DRIVER

A2540SLB

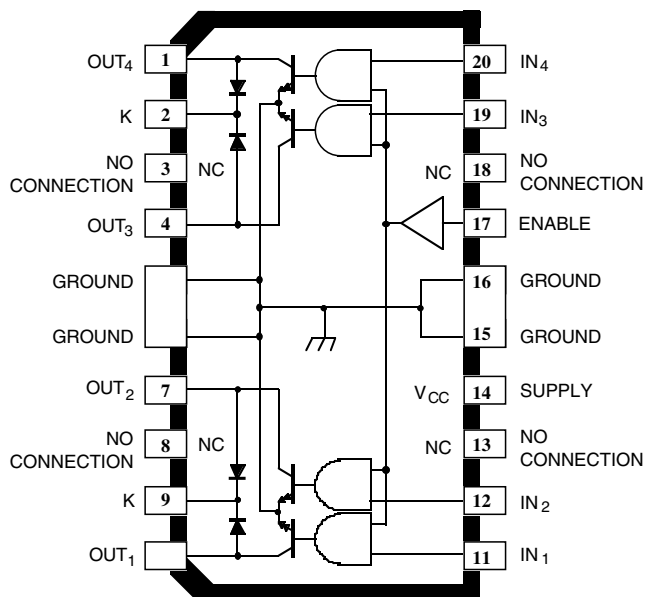

Dwg. PP-017-3

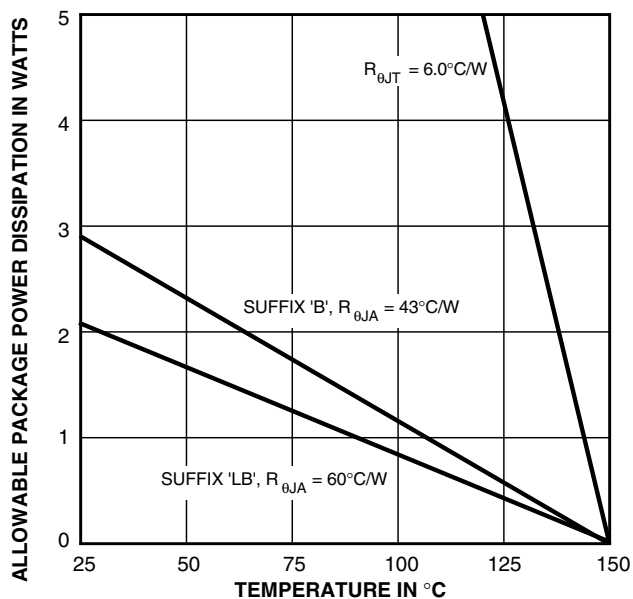

Dwg. GP-049-3

TRUTH TABLE

ENABLE	IN _N	OUT _N
H	H	ON
—	L	OFF
L	X	OFF

X = Don't care.

2540
QUAD DARLINGTON
POWER DRIVER

ELECTRICAL CHARACTERISTICS at $T_A = 25^\circ\text{C}$, $T_J \leq 150^\circ\text{C}$, $V_{CC} = 4.75\text{ V to }5.25\text{ V}$.

Characteristic	Symbol	Test Conditions	Limits			Units
			Min.	Typ.	Max.	
Output Leakage Current	I_{CEX}	$V_{OUT} = 50\text{ V}$, $V_{IN} = 0.8\text{ V}$, $V_{EN} = 2.4\text{ V}$	—	<1.0	100	μA
		$V_{OUT} = 50\text{ V}$, $V_{IN} = 2.4\text{ V}$, $V_{EN} = 0.8\text{ V}$	—	<1.0	100	μA
Output Sustaining Voltage	$V_{CE(sus)}$	$I_{OUT} = 1.8\text{ A}$, $L = 3.0\text{ mH}$	50	—	—	V
Output Saturation Voltage	$V_{CE(SAT)}$	$I_{OUT} = 600\text{ mA}$, $V_{IN} = V_{EN} = 2.4\text{ V}$	—	0.9	1.0	V
		$I_{OUT} = 1.0\text{ A}$, $V_{IN} = V_{EN} = 2.4\text{ V}$	—	1.0	1.2	V
		$I_{OUT} = 1.8\text{ A}$, $V_{IN} = V_{EN} = 2.4\text{ V}$	—	1.3	1.6	V
Input Voltage	Logic 1	$V_{IN(1)}$ or $V_{EN(1)}$	2.4	—	—	V
	Logic 0	$V_{IN(0)}$ or $V_{EN(0)}$	—	—	0.8	V
Input Current	Logic 1	$V_{IN(1)}$ or $V_{EN(1)} = 2.4\text{ V}$	—	—	10	μA
	Logic 0	$V_{IN(0)}$ or $V_{EN(0)} = 0.8\text{ V}$	—	—	-100	μA
Total Supply Current	I_{CC}	$V_{IN}^* = V_{EN} = 2.4\text{ V}$, $V_{CC} = 5.0\text{ V}$, Outputs Open	—	14	20	mA
		$V_{IN}^* = V_{EN} = 0.8\text{ V}$, $V_{CC} = 5.0\text{ V}$	—	0.4	2.0	mA
Clamp Diode Forward Voltage	V_F	$I_F = 1.0\text{ A}$	—	1.3	1.6	V
		$I_F = 1.8\text{ A}$	—	1.6	2.0	V
Clamp Diode Leakage Current	I_R	$V_R = 50\text{ V}$	—	<1.0	100	μA

Typical Data is for design information only.

Negative current is defined as coming out of (sourcing) the specified terminal.

As used here, -100 is defined as greater than +10 (absolute magnitude convention) and the minimum is implicitly zero.

*All inputs simultaneously, all other tests are performed with each input tested separately.

2540 QUAD DARLINGTON POWER DRIVER

TYPICAL APPLICATION (QUAD RELAY DRIVER WITH ZENER FLYBACK)

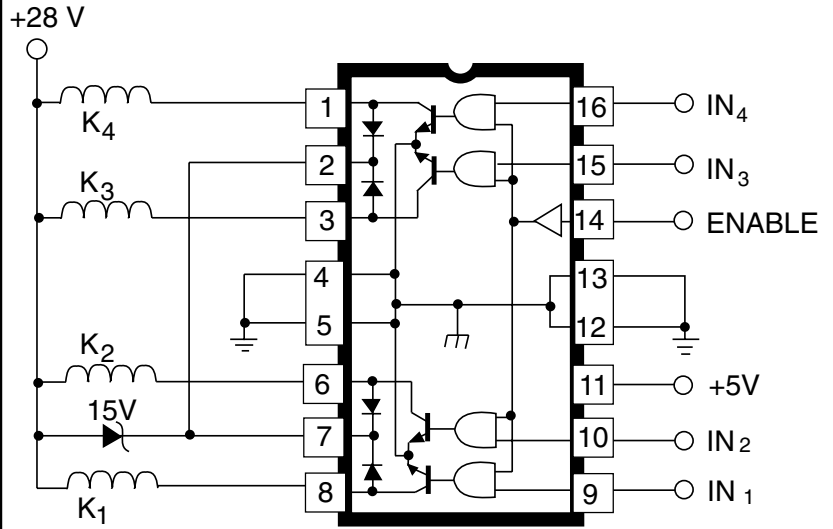

Dwg. EP-016

APPLICATIONS INFORMATION

A typical application is shown for driving four high-current relays, solenoids, or print heads. A Zener diode is used to increase the flyback voltage, providing a much faster inductive load turn-off current decay, resulting in faster dropout (reduced relay contact arcing), and improved performance. The maximum Zener voltage, plus the load supply voltage, plus the flyback diode forward voltage must not exceed the device's rated sustaining voltage.

With external control circuitry, the ENABLE input can be used for chopper (PWM) applications. If the ENABLE input is not used, it should be tied high.

All inputs will float high if open circuited.

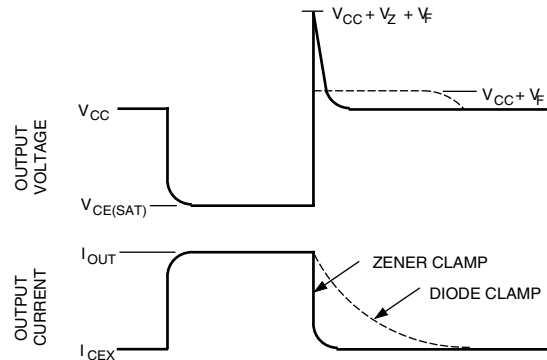

Dwg. WP-001

2540 QUAD DARLINGTON POWER DRIVER

UDN2540B Dimensions in Inches (controlling dimensions)

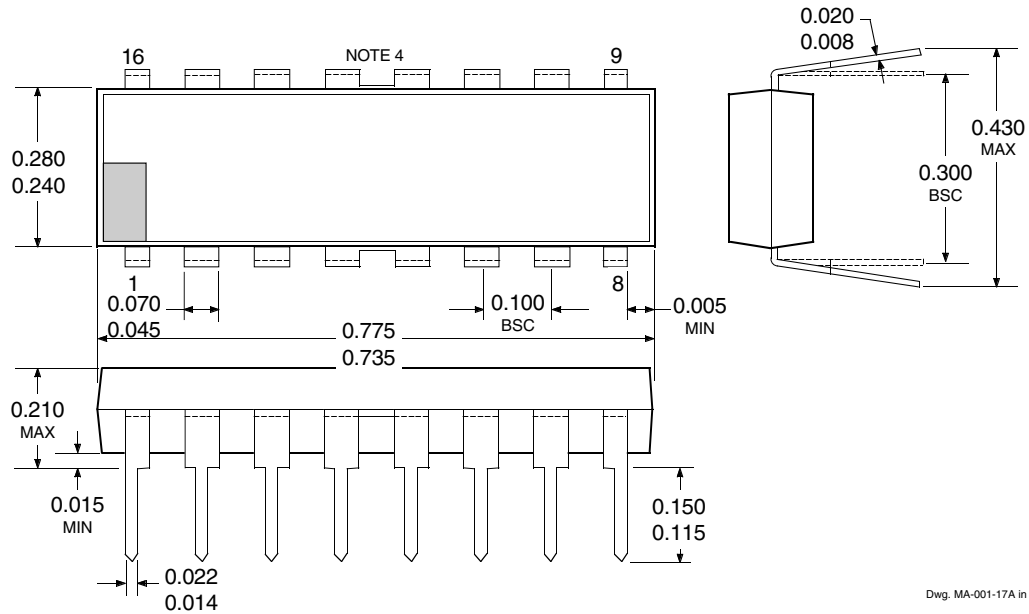

Dimensions in Millimeters (for reference only)

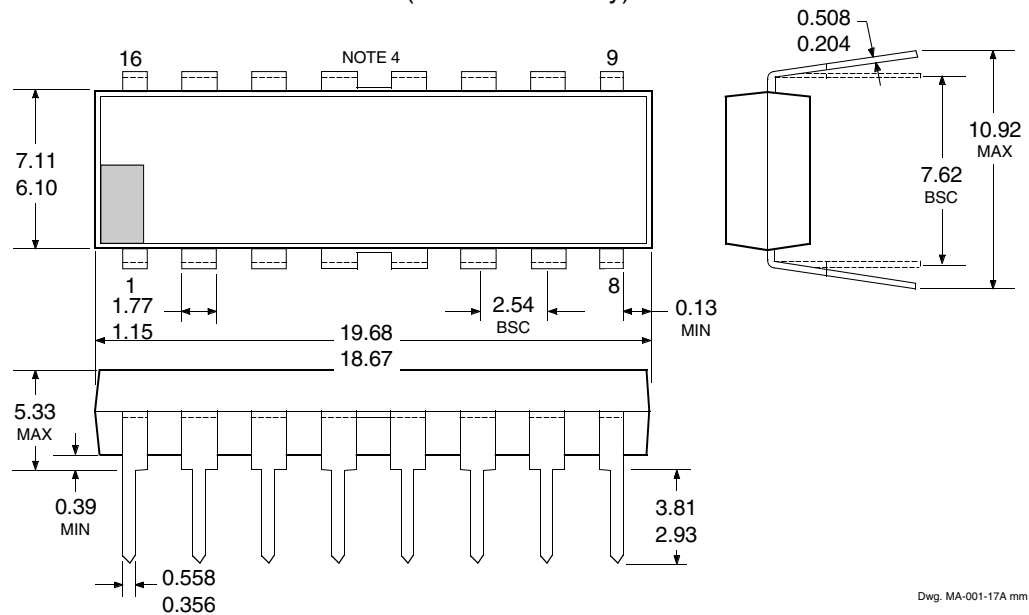

- NOTES: 1. Leads 1, 8, 9, and 16 may be half leads at vendor's option.
 2. Lead thickness is measured at seating plane or below.
 3. Lead spacing tolerance is non-cumulative.
 4. Webbed lead frame. Leads indicated are internally one piece.
 5. Exact body and lead configuration at vendor's option within limits shown.

2540 QUAD DARLINGTON POWER DRIVER

A2540SLB Dimensions in Inches (for reference only)

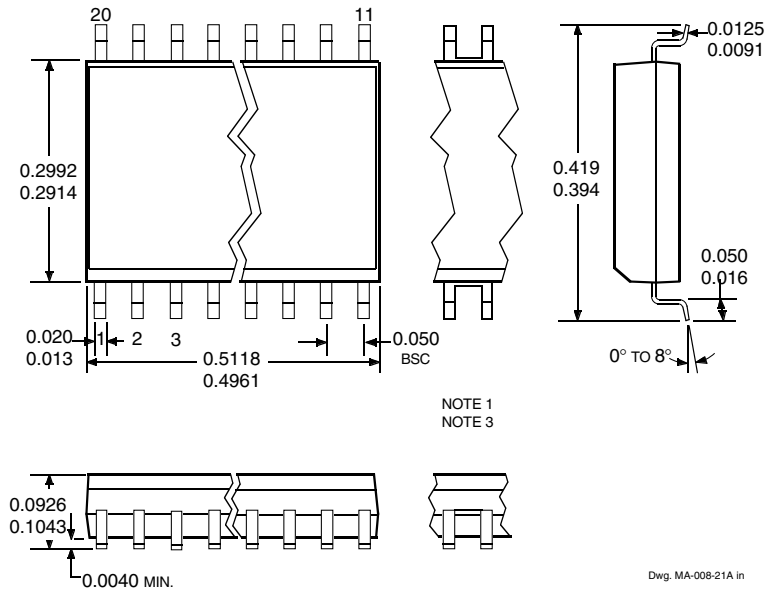

Dimensions in Millimeters (controlling dimensions)

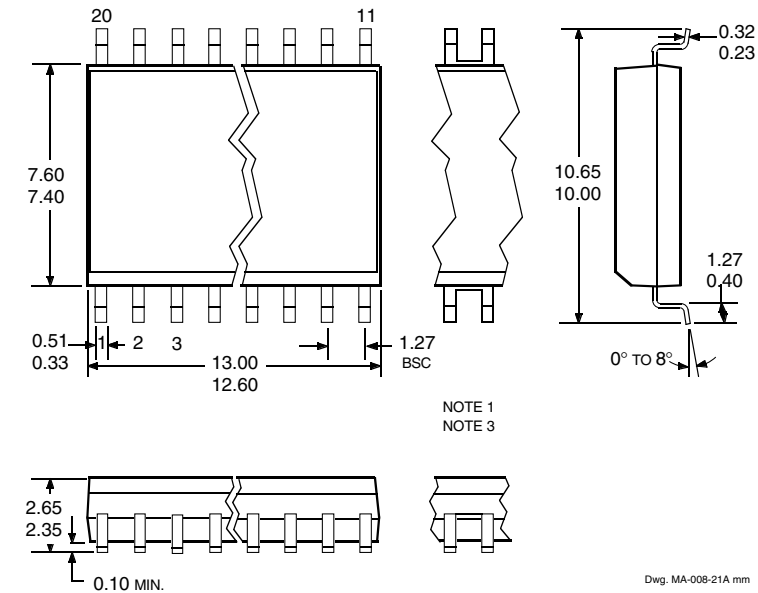

- NOTES: 1. Webbed lead frame. Leads 5, 6, 15, and 16 are internally one piece.
2. Lead spacing tolerance is non-cumulative.
3. Exact body and lead configuration at vendor's option within limits shown.

2540
QUAD DARLINGTON
POWER DRIVER

The products described here are manufactured under one or more U.S. patents or U.S. patents pending.

Allegro MicroSystems, Inc. reserves the right to make, from time to time, such departures from the detail specifications as may be required to permit improvements in the performance, reliability, or manufacturability of its products. Before placing an order, the user is cautioned to verify that the information being relied upon is current.

Allegro products are not authorized for use as critical components in life-support devices or systems without express written approval.

The information included herein is believed to be accurate and reliable. However, Allegro MicroSystems, Inc. assumes no responsibility for its use; nor for any infringement of patents or other rights of third parties which may result from its use.

2540 QUAD DARLINGTON POWER DRIVER

POWER SINK DRIVERS

IN ORDER OF 1) OUTPUT CURRENT, 2) OUTPUT VOLTAGE, 3) NUMBER OF DRIVERS

Output Ratings *			Features					Part Number †	
mA	V	#	Serial Input	Latched Drivers	Diode Clamp	Outputs	Internal Protection		
75	17	8	X	X	–	constant current	–	6275	
	17	16	X	X	–	constant current	–	6276	
100	20	8	–	–	–	saturated	–	2595	
	30	32	X	X	–	–	–	5833	
	40	32	X	X	–	saturated	–	5832	
	50	8	addressable decoder/driver			–	DMOS	–	6B259
	50	8	–	X	–	DMOS	–	6B273	
	50	8	X	X	–	DMOS	–	6B595	
250	50	8	addressable decoder/driver			–	DMOS	–	6259
	50	8	–	X	–	DMOS	–	6273	
	50	8	X	X	–	DMOS	–	6595	
	135	7	–	–	X	–	–	7003	
300	45	1	–	Hall sensor/driver	X	–	X	5140	
	50	7	–	–	X	–	–	2003	
	50	8	–	–	X	–	–	2803	
	50	8	–	–	X	saturated	–	2596	
	60	4	–	–	X	saturated	X	2557	
	95	7	–	–	X	–	–	2023	
	95	8	–	–	X	–	–	2823	
350	50	4	–	X	X	–	–	5800	
	50	7	–	–	X	–	–	2004	
	50	8	–	–	X	–	–	2804	
	50	8	–	X	X	–	–	5801	
	50	8	X	X	–	–	–	5821	
	50	8	X	X	X	–	–	5841	
	50	8	addressable decoder/driver			–	DMOS	–	6A259
	50	8	X	X	–	DMOS	–	6A595	
	80	8	X	X	–	–	–	5822	
	80	8	X	X	X	–	–	5842	
	95	7	–	–	X	–	–	2024	
	95	8	–	–	X	–	–	2824	
450	30	28	dual 4- to 14-line decoder/driver			–	–	6817	
600	60	4	–	–	–	saturated	X	2547	
	60	4	–	–	X	saturated	X	2549	
700	60	4	–	–	X	saturated	X	2543 and 2559	
750	50	8	–	–	X	saturated	–	2597	
900	14	2	–	Hall sensor/driver	X	saturated	X	3625	
	26	2	–	Hall sensor/driver	X	saturated	X	3626	
1000	46	4	stepper motor controller/driver			MOS	–	7024 and 7029	
1200	46	4	microstepping controller/driver			MOS	–	7042	
1250	50	4	stepper motor translator/driver			–	X	5804	
	50	4	–	–	X	–	–	2064 and 2068	
1500	80	4	–	–	X	–	–	2065 and 2069	
1800	50	4	–	–	X	–	–	2544	
	50	4	–	–	X	–	–	2540	
3000	46	4	stepper motor controller/driver			MOS	–	7026	
	46	4	microstepping controller/driver			MOS	–	7044	
4000	50	4	–	–	X	–	–	2878	
	80	4	–	–	X	–	–	2879	

* Current is maximum specified test condition, voltage is maximum rating. See specification for sustaining voltage limits or over-current protection voltage limits.

† Complete part number includes additional characters to indicate operating temperature range and package style.



115 Northeast Cutoff, Box 15036
Worcester, Massachusetts 01615-0036 (508) 853-5000

This datasheet has been downloaded from:

www.DatasheetCatalog.com

Datasheets for electronic components.



LittleDiode supplies new, hard to find or obsolete electronic components and semiconductors all over the world.

With over two million different components listed you are sure to find the part you need.

Feel free to visit us today at our online store:

LittleDiode.com

Looking forward to providing you with the best possible service.