

MECHANICAL DATA

Dimensions in mm

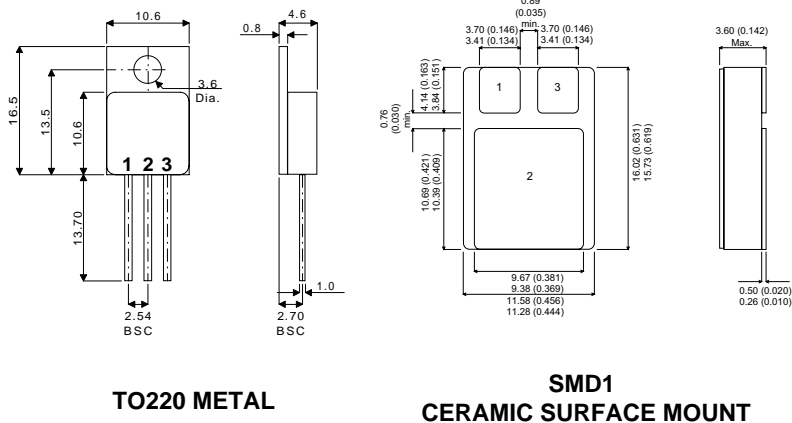

**HERMETICALLY SEALED
DUAL FAST RECOVERY
SILICON RECTIFIER
FOR HI-REL APPLICATIONS**

- STANDARD (COMMON CATHODE)
- COMMON ANODE
- SERIES CONNECTION

FEATURES

- HERMETIC TO220 METAL OR CERAMIC SURFACE MOUNT PACKAGE
- SCREENING OPTIONS AVAILABLE
- ALL LEADS ISOLATED FROM CASE
- VOLTAGE RANGE 50 TO 200V
- AVERAGE CURRENT 20A
- VERY LOW REVERSE RECOVERY TIME – $t_{rr} = 35ns$
- VERY LOW SWITCHING LOSSES

ELECTRICAL CONNECTIONS

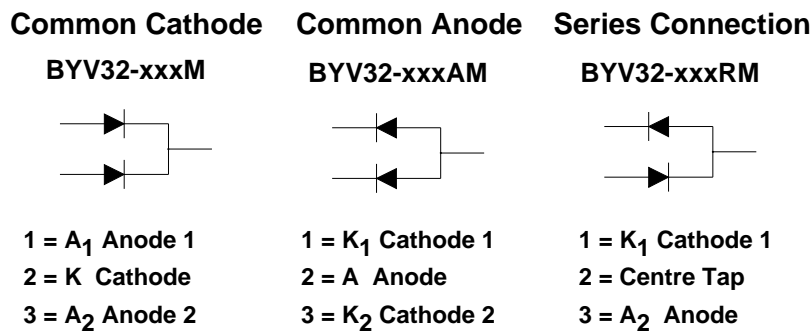

Applications include secondary rectification in high frequency switching power supplies.

ABSOLUTE MAXIMUM RATINGS ($T_{case} = 25^{\circ}C$ unless otherwise stated)		BYV32 -50M	BYV32 -100M	BYV32 -150M	BYV32 -200M
V_{RRM}	Peak Repetitive Reverse Voltage	50V	100V	150V	200V
V_{RWM}	Working Peak Reverse Voltage	50V	100V	150V	200V
V_R	Continuous Reverse Voltage	50V	100V	150V	200V
I_{FRM}	Repetitive Peak Forward Current $t_p = 10\mu s$			200A	
$I_{F(AV)}$	Average Forward Current $T_{case} = 70^{\circ}C$ (switching operation, $\delta = 0.5$, both diodes conducting)			20A	
I_{FSM}	Surge Non Repetitive Forward Current $t_p = 10 ms$			80A	
T_{stg}	Storage Temperature Range			-65 to 200°C	
T_j	Maximum Operating Junction Temperature			200°C	

ELECTRICAL CHARACTERISTICS (Per Diode) ($T_{case} = 25^{\circ}C$ unless otherwise stated)

Parameter	Test Conditions	Min.	Typ.	Max.	Unit
I_R Reverse Current	$V_R = V_{RWM}$ $T_j = 25^{\circ}C$			30	μA
	$V_R = V_{RWM}$ $T_j = 100^{\circ}C$			0.6	mA
V_F * Forward Voltage	$I_F = 8A$ $T_C = 25^{\circ}C$			1.1	V
	$I_F = 20A$ $T_C = 25^{\circ}C$			1.5	
	$I_F = 5A$ $T_C = 100^{\circ}C$			0.95	
t_{rr} Reverse Recovery Time	$I_F = 2A$ $V_R = 30V$ $di / dt = 20A/\mu s$			35	ns
	$I_F = 1A$ $V_R = 30V$ $di / dt = 50A/\mu s$			50	ns
Q_{rr} Recovered Charge	$I_F = 2A$ $V_R = 30V$ $di / dt = 20A/\mu s$			15	nC
V_{Fp} Forward Recovery Overvoltage	$di / dt = 10A/\mu s$ $I_F = 1A$		1.0		V

* Pulse Test: $t_p \leq 300\mu s$, duty cycle $\leq 2\%$.

THERMAL CHARACTERISTICS (TO220 METAL CASE)

$R_{\theta JC}^{\dagger}$ Thermal Resistance Junction – Case			1.6	$^{\circ}C/W$
--	--	--	-----	---------------

\dagger Both diodes conducting.



LittleDiode supplies new, hard to find or obsolete electronic components and semiconductors all over the world.

With over two million different components listed you are sure to find the part you need.

Feel free to visit us today at our online store:

LittleDiode.com

Looking forward to providing you with the best possible service.