

# 74ALVC125

Quad buffer/line driver; 3-state

Rev. 02 — 10 January 2008

Product data sheet

## 1. General description

The 74ALVC125 is a quad non-inverting buffer/line driver with 3-state outputs. The 3-state outputs ( $nY$ ) are controlled by the output enable input ( $n\overline{OE}$ ). A HIGH on the  $n\overline{OE}$  pin causes the outputs to assume a high-impedance OFF-state.

## 2. Features

- Wide supply voltage range from 1.65 V to 3.6 V
- 3.6 V tolerant inputs/outputs
- CMOS low power consumption
- Direct interface with TTL levels (2.7 V to 3.6 V)
- Power-down mode
- Latch-up performance exceeds 250 mA
- Complies with JEDEC standards:
  - ◆ JESD8-7 (1.65 V to 1.95 V)
  - ◆ JESD8-5 (2.3 V to 2.7 V)
  - ◆ JESD8B/JESD36 (2.7 V to 3.6 V)
- ESD protection:
  - ◆ HBM JESD22-A114E exceeds 2000 V
  - ◆ MM JESD22-A 115-A exceeds 200 V

## 3. Ordering information

Table 1. Ordering information

Type number	Package			
	Temperature range	Name	Description	Version
74ALVC125D	-40 °C to +85 °C	SO14	plastic small outline package; 14 leads; body width 3.9 mm	SOT108-1
74ALVC125PW	-40 °C to +85 °C	TSSOP14	plastic thin shrink small outline package; 14 leads; body width 4.4 mm	SOT402-1
74ALVC125BQ	-40 °C to +85 °C	DHVQFN14	plastic dual in-line compatible thermal enhanced very thin quad flat package; no leads; 14 terminals; body 2.5 × 3 × 0.85 mm	SOT762-1

### 4. Functional diagram

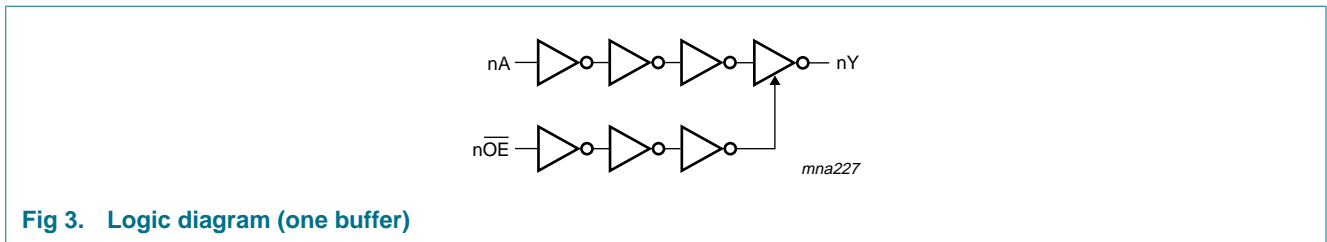
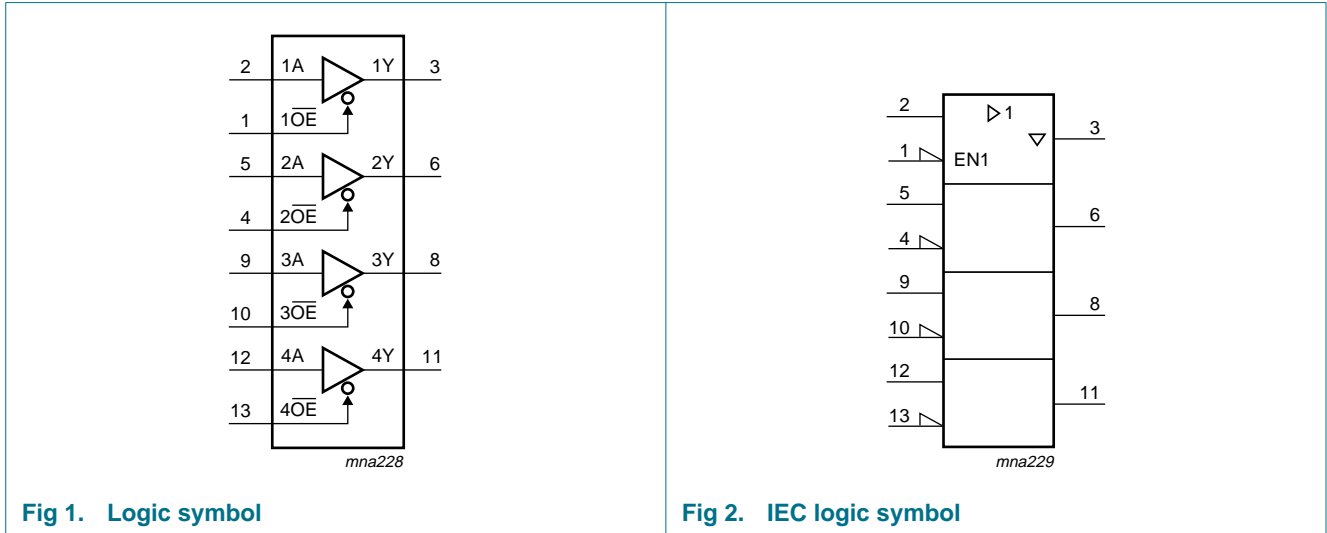

### 5. Pinning information

#### 5.1 Pinning

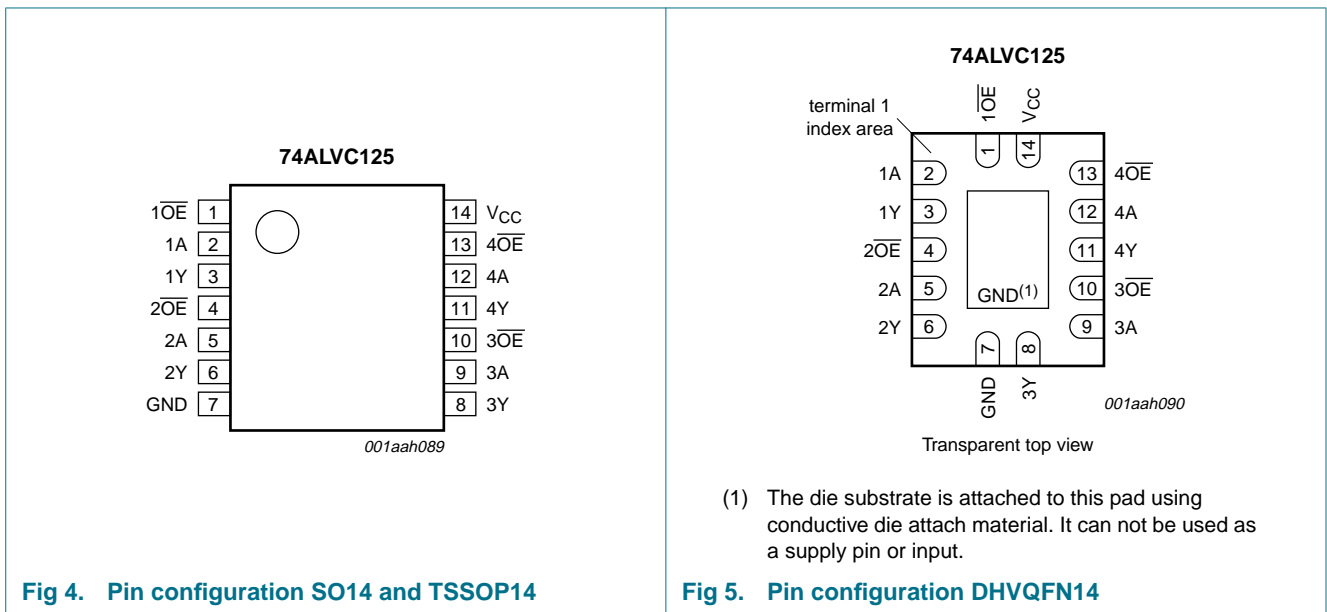

(1) The die substrate is attached to this pad using conductive die attach material. It can not be used as a supply pin or input.

## 5.2 Pin description

**Table 2.** Pin description

Symbol	Pin	Description
nA	2, 5, 9, 12	data input
nY	3, 6, 8, 11	bus output
n $\overline{\text{OE}}$	1, 4, 10, 13	output enable (active LOW)
V <sub>CC</sub>	14	supply voltage
GND	7	ground (0 V)

## 6. Functional description

**Table 3.** Function table<sup>[1]</sup>

Input		Output
n $\overline{\text{OE}}$	nA	nY
L	L	L
L	H	H
H	X	Z

- [1] H = HIGH voltage level  
 L = LOW voltage level  
 X = don't care  
 Z = high-impedance OFF-state

## 7. Limiting values

**Table 4.** Limiting values

In accordance with the Absolute Maximum Rating System (IEC 60134). Voltages are referenced to GND (ground = 0 V).

Symbol	Parameter	Conditions	Min	Max	Unit
V <sub>CC</sub>	supply voltage		-0.5	+4.6	V
I <sub>IK</sub>	input clamping current	V <sub>I</sub> < 0 V	-50	-	mA
V <sub>I</sub>	input voltage		[1] -0.5	+4.6	V
I <sub>OK</sub>	output clamping current	V <sub>O</sub> > V <sub>CC</sub> or V <sub>O</sub> < 0 V	-	±50	mA
V <sub>O</sub>	output voltage	output HIGH or LOW state	[1][2] -0.5	V <sub>CC</sub> + 0.5	V
		output 3-state	-0.5	+4.6	V
		Power-down mode, V <sub>CC</sub> = 0 V	[2] -0.5	+4.6	V
I <sub>O</sub>	output current	V <sub>O</sub> = 0 V to V <sub>CC</sub>	-	±50	mA
I <sub>CC</sub>	supply current		-	100	mA
I <sub>GND</sub>	ground current		-100	-	mA
T <sub>stg</sub>	storage temperature		-65	+150	°C
P <sub>tot</sub>	total power dissipation	T <sub>amb</sub> = -40 °C to +85 °C	[3] -	500	mW

- [1] The minimum input voltage ratings may be exceeded if the input current ratings are observed.  
 [2] When V<sub>CC</sub> = 0 V (Power-down mode), the output voltage can be 3.6 V in normal operation.  
 [3] For SO14 packages: above 70 °C derate linearly with 8 mW/K.  
 For TSSOP14 packages: above 60 °C derate linearly with 5.5 mW/K.  
 For DHVQFN20 packages: above 60 °C derate linearly with 4.5 mW/K.

## 8. Recommended operating conditions

**Table 5. Recommended operating conditions**

Symbol	Parameter	Conditions	Min	Max	Unit
V <sub>CC</sub>	supply voltage		1.65	3.6	V
V <sub>I</sub>	input voltage		0	3.6	V
V <sub>O</sub>	output voltage	output HIGH or LOW state	0	V <sub>CC</sub>	V
		output 3-state	0	3.6	V
		Power-down mode; V <sub>CC</sub> = 0 V	0	3.6	V
T <sub>amb</sub>	ambient temperature	in free air	-40	+85	°C
Δt/ΔV	input transition rise and fall rate	V <sub>CC</sub> = 1.65 V to 2.7 V	0	20	ns/V
		V <sub>CC</sub> = 2.7 V to 3.6 V	0	10	ns/V

## 9. Static characteristics

**Table 6. Static characteristics**

At recommended operating conditions. Voltages are referenced to GND (ground = 0 V).

Symbol	Parameter	Conditions	-40 °C to +85 °C			Unit
			Min	Typ <sup>[1]</sup>	Max	
V <sub>IH</sub>	HIGH-level input voltage	V <sub>CC</sub> = 1.65 V to 1.95 V	0.65 × V <sub>CC</sub>	-	-	V
		V <sub>CC</sub> = 2.3 V to 2.7 V	1.7	-	-	V
		V <sub>CC</sub> = 2.7 V to 3.6 V	2.0	-	-	V
V <sub>IL</sub>	LOW-level input voltage	V <sub>CC</sub> = 1.65 V to 1.95 V	-	-	0.35 × V <sub>CC</sub>	V
		V <sub>CC</sub> = 2.3 V to 2.7 V	-	-	0.7	V
		V <sub>CC</sub> = 2.7 V to 3.6 V	-	-	0.8	V
V <sub>OH</sub>	HIGH-level output voltage	V <sub>I</sub> = V <sub>IH</sub> or V <sub>IL</sub>				
		I <sub>O</sub> = -100 μA; V <sub>CC</sub> = 1.65 V to 3.6 V	V <sub>CC</sub> - 0.2	-	-	V
		I <sub>O</sub> = -6 mA; V <sub>CC</sub> = 1.65 V	1.25	1.51	-	V
		I <sub>O</sub> = -12 mA; V <sub>CC</sub> = 2.3 V	1.8	2.10	-	V
		I <sub>O</sub> = -18 mA; V <sub>CC</sub> = 2.3 V	1.7	2.01	-	V
		I <sub>O</sub> = -12 mA; V <sub>CC</sub> = 2.7 V	2.2	2.53	-	V
		I <sub>O</sub> = -18 mA; V <sub>CC</sub> = 3.0 V	2.4	2.76	-	V
		I <sub>O</sub> = -24 mA; V <sub>CC</sub> = 3.0 V	2.2	2.68	-	V
V <sub>OL</sub>	LOW-level output voltage	V <sub>I</sub> = V <sub>IH</sub> or V <sub>IL</sub>				
		I <sub>O</sub> = 100 μA; V <sub>CC</sub> = 1.65 V to 3.6 V	-	-	0.2	V
		I <sub>O</sub> = 6 mA; V <sub>CC</sub> = 1.65 V	-	0.11	0.3	V
		I <sub>O</sub> = 12 mA; V <sub>CC</sub> = 2.3 V	-	0.17	0.4	V
		I <sub>O</sub> = 18 mA; V <sub>CC</sub> = 2.3 V	-	0.25	0.6	V
		I <sub>O</sub> = 12 mA; V <sub>CC</sub> = 2.7 V	-	0.16	0.4	V
		I <sub>O</sub> = 18 mA; V <sub>CC</sub> = 3.0 V	-	0.23	0.4	V
		I <sub>O</sub> = 24 mA; V <sub>CC</sub> = 3.0 V	-	0.30	0.55	V
I <sub>I</sub>	input leakage current	V <sub>CC</sub> = 3.6 V; V <sub>I</sub> = 3.6 V or GND	-	±0.1	±5	μA

**Table 6. Static characteristics ...continued**

At recommended operating conditions. Voltages are referenced to GND (ground = 0 V).

Symbol	Parameter	Conditions	-40 °C to +85 °C			Unit
			Min	Typ <sup>[1]</sup>	Max	
I <sub>OZ</sub>	OFF-state output current	V <sub>I</sub> = V <sub>IH</sub> or V <sub>IL</sub> ; V <sub>CC</sub> = 1.65 V to 3.6 V; V <sub>O</sub> = 3.6 V or GND;	-	±0.1	±10	µA
I <sub>OFF</sub>	power-off leakage current	V <sub>CC</sub> = 0 V; V <sub>I</sub> or V <sub>O</sub> = 0 V to 3.6 V	-	±0.1	±10	µA
I <sub>CC</sub>	supply current	V <sub>CC</sub> = 3.6 V; V <sub>I</sub> = V <sub>CC</sub> or GND; I <sub>O</sub> = 0 A	-	0.2	10	µA
ΔI <sub>CC</sub>	additional supply current	per input pin; V <sub>CC</sub> = 3.0 V to 3.6 V; V <sub>I</sub> = V <sub>CC</sub> - 0.6 V; I <sub>O</sub> = 0 A	-	5	750	µA
C <sub>I</sub>	input capacitance		-	3.5	-	pF

[1] All typical values are measured at V<sub>CC</sub> = 3.3 V (unless stated otherwise) and T<sub>amb</sub> = 25 °C.

## 10. Dynamic characteristics

**Table 7. Dynamic characteristics**

Voltages are referenced to GND (ground = 0 V). For test circuit see [Figure 8](#).

Symbol	Parameter	Conditions	-40 °C to +85 °C			Unit
			Min	Typ <sup>[1]</sup>	Max	
t <sub>pd</sub>	propagation delay	nA to nY; see <a href="#">Figure 6</a> <sup>[2]</sup>				
		V <sub>CC</sub> = 1.65 V to 1.95 V	1.3	2.4	5.3	ns
		V <sub>CC</sub> = 2.3 V to 2.7 V	1.0	1.7	3.2	ns
		V <sub>CC</sub> = 2.7 V	-	2.0	3.1	ns
		V <sub>CC</sub> = 3.0 V to 3.6 V	1.1	1.8	2.8	ns
t <sub>en</sub>	enable time	n $\overline{O}E$ to nY; see <a href="#">Figure 7</a> <sup>[2]</sup>				
		V <sub>CC</sub> = 1.65 V to 1.95 V	1.4	3.9	6.4	ns
		V <sub>CC</sub> = 2.3 V to 2.7 V	1.0	2.2	4.1	ns
		V <sub>CC</sub> = 2.7 V	-	2.7	4.3	ns
		V <sub>CC</sub> = 3.0 V to 3.6 V	1.0	1.9	3.5	ns
t <sub>dis</sub>	disable time	n $\overline{O}E$ to nY; see <a href="#">Figure 7</a> <sup>[2]</sup>				
		V <sub>CC</sub> = 1.65 V to 1.95 V	1.8	3.9	5.9	ns
		V <sub>CC</sub> = 2.3 V to 2.7 V	1.0	2.1	3.4	ns
		V <sub>CC</sub> = 2.7 V	-	2.9	4.0	ns
		V <sub>CC</sub> = 3.0 V to 3.6 V	1.4	2.7	4.0	ns

**Table 7. Dynamic characteristics ...continued**  
 Voltages are referenced to GND (ground = 0 V). For test circuit see [Figure 8](#).

Symbol	Parameter	Conditions	-40 °C to +85 °C			Unit
			Min	Typ <sup>[1]</sup>	Max	
C <sub>PD</sub>	power dissipation capacitance	per buffer; V <sub>I</sub> = GND to V <sub>CC</sub> ; V <sub>CC</sub> = 3.3 V <sup>[3]</sup>				
		outputs HIGH or LOW state	-	27	-	pF
		outputs 3-state	-	5	-	pF

- [1] Typical values are measured at T<sub>amb</sub> = 25 °C
- [2] t<sub>pd</sub> is the same as t<sub>PHL</sub> and t<sub>PLH</sub>.  
 t<sub>en</sub> is the same as t<sub>PZH</sub> and t<sub>PZL</sub>.  
 t<sub>dis</sub> is the same as t<sub>PHZ</sub> and t<sub>PLZ</sub>.
- [3] C<sub>PD</sub> is used to determine the dynamic power dissipation (P<sub>D</sub> in μW).  
 $P_D = C_{PD} \times V_{CC}^2 \times f_i \times N + \Sigma(C_L \times V_{CC}^2 \times f_o)$  where:  
 f<sub>i</sub> = input frequency in MHz; f<sub>o</sub> = output frequency in MHz  
 C<sub>L</sub> = output load capacitance in pF  
 V<sub>CC</sub> = supply voltage in Volts  
 N = number of inputs switching  
 Σ(C<sub>L</sub> × V<sub>CC</sub><sup>2</sup> × f<sub>o</sub>) = sum of the outputs

## 11. Waveforms

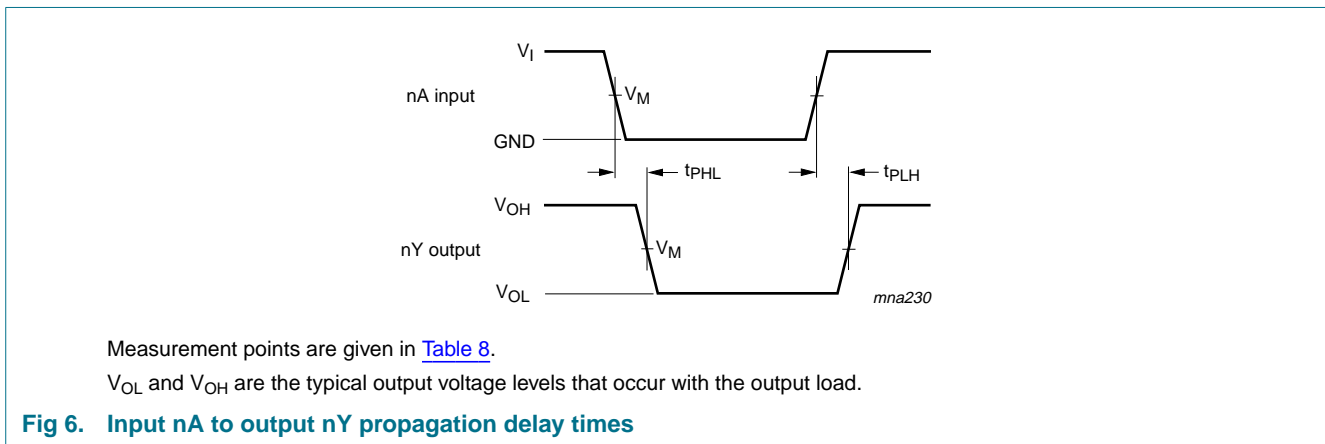

**Table 8. Measurement points**

Supply voltage	Input	Output		
V <sub>CC</sub>	V <sub>M</sub>	V <sub>M</sub>	V <sub>X</sub>	V <sub>Y</sub>
1.65 V to 1.95 V	0.5V <sub>CC</sub>	0.5V <sub>CC</sub>	V <sub>OL</sub> + 0.15 V	V <sub>OH</sub> - 0.15 V
2.3 V to 2.7 V	0.5V <sub>CC</sub>	0.5V <sub>CC</sub>	V <sub>OL</sub> + 0.15 V	V <sub>OH</sub> - 0.15 V
2.7 V	1.5 V	1.5 V	V <sub>OL</sub> + 0.3 V	V <sub>OH</sub> - 0.3 V
3.0 V to 3.6 V	1.5 V	1.5 V	V <sub>OL</sub> + 0.3 V	V <sub>OH</sub> - 0.3 V

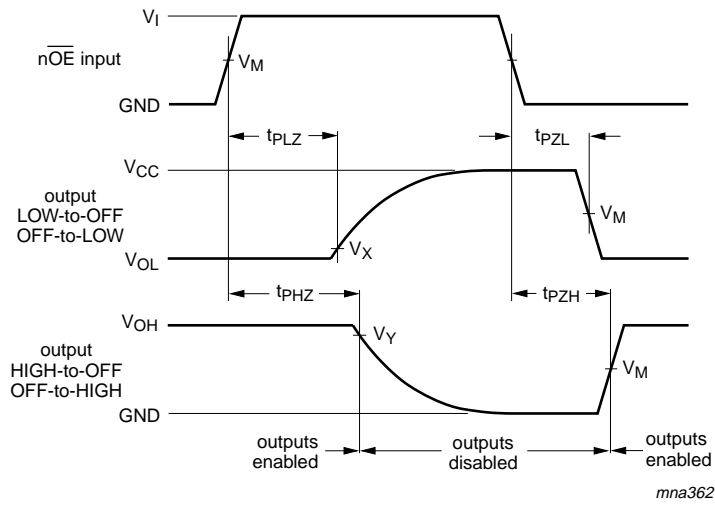

Measurement points are given in [Table 8](#).

$V_{OL}$  and  $V_{OH}$  are the typical output voltage levels that occur with the output load.

**Fig 7. Enable and disable times**

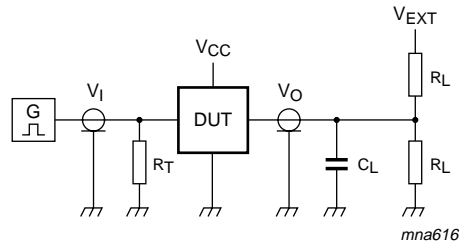

Test data is given in [Table 9](#).

Definitions for test circuit:

$R_L$  = Load resistance.

$C_L$  = Load capacitance including jig and probe capacitance.

$R_T$  = Termination resistance should be equal to output impedance  $Z_o$  of the pulse generator.

$V_{EXT}$  = External voltage for measuring switching times.

**Fig 8. Test circuitry for switching times**

**Table 9. Test data**

Supply voltage	Input		Load		$V_{EXT}$		
	$V_I$	$t_r, t_f$	$C_L$	$R_L$	$t_{PLH}, t_{PHL}$	$t_{PLZ}, t_{PZL}$	$t_{PHZ}, t_{PZH}$
1.65 V to 1.95 V	$V_{CC}$	$\leq 2.0$ ns	30 pF	1 k $\Omega$	open	$2 \times V_{CC}$	GND
2.3 V to 2.7 V	$V_{CC}$	$\leq 2.0$ ns	30 pF	500 $\Omega$	open	$2 \times V_{CC}$	GND
2.7 V	2.7 V	$\leq 2.5$ ns	50 pF	500 $\Omega$	open	6 V	GND
3.0 V to 3.6 V	2.7 V	$\leq 2.5$ ns	50 pF	500 $\Omega$	open	6 V	GND

12. Package outline

SO14: plastic small outline package; 14 leads; body width 3.9 mm

SOT108-1

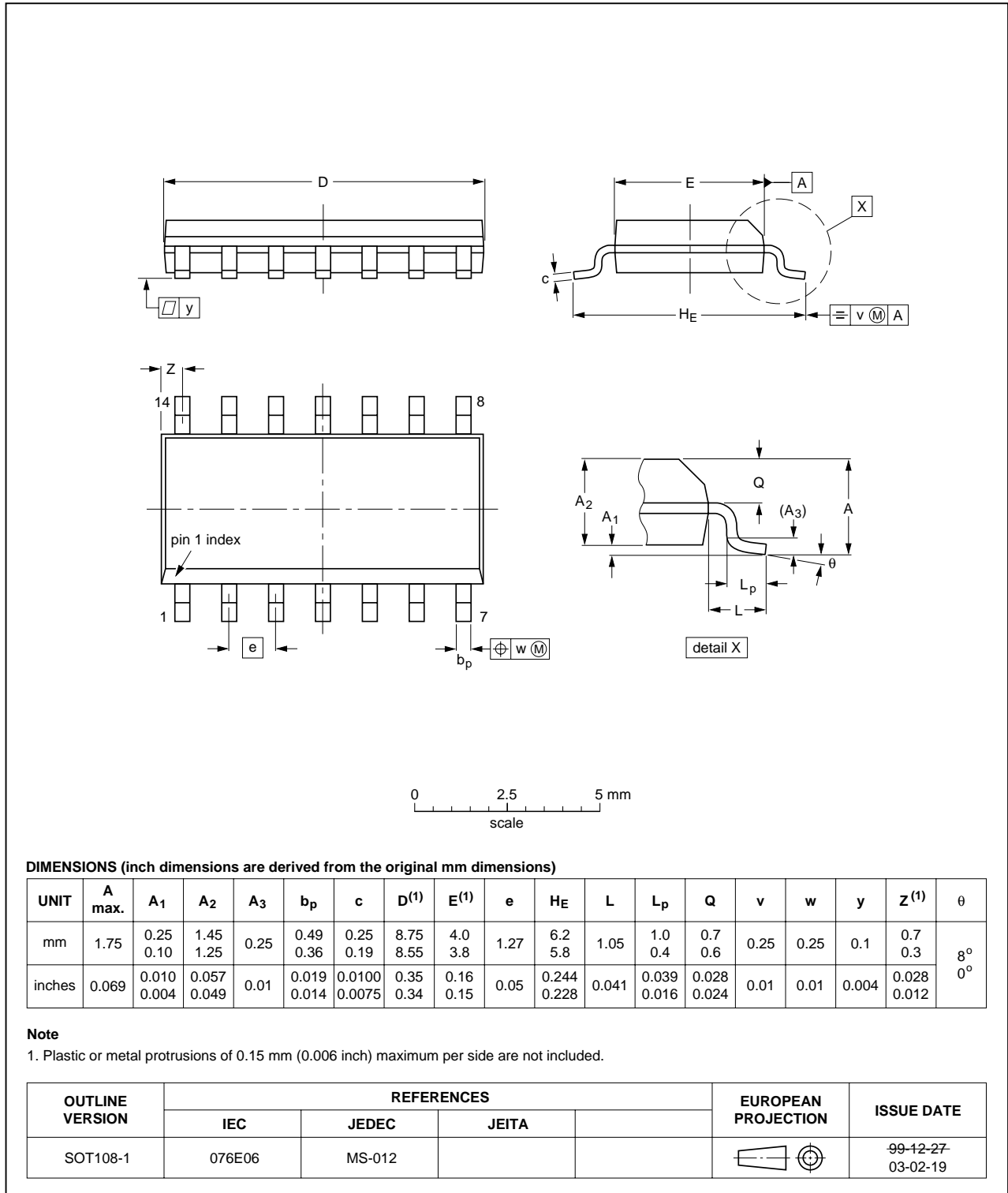

Fig 9. Package outline SOT108-1 (SO14)

TSSOP14: plastic thin shrink small outline package; 14 leads; body width 4.4 mm

SOT402-1

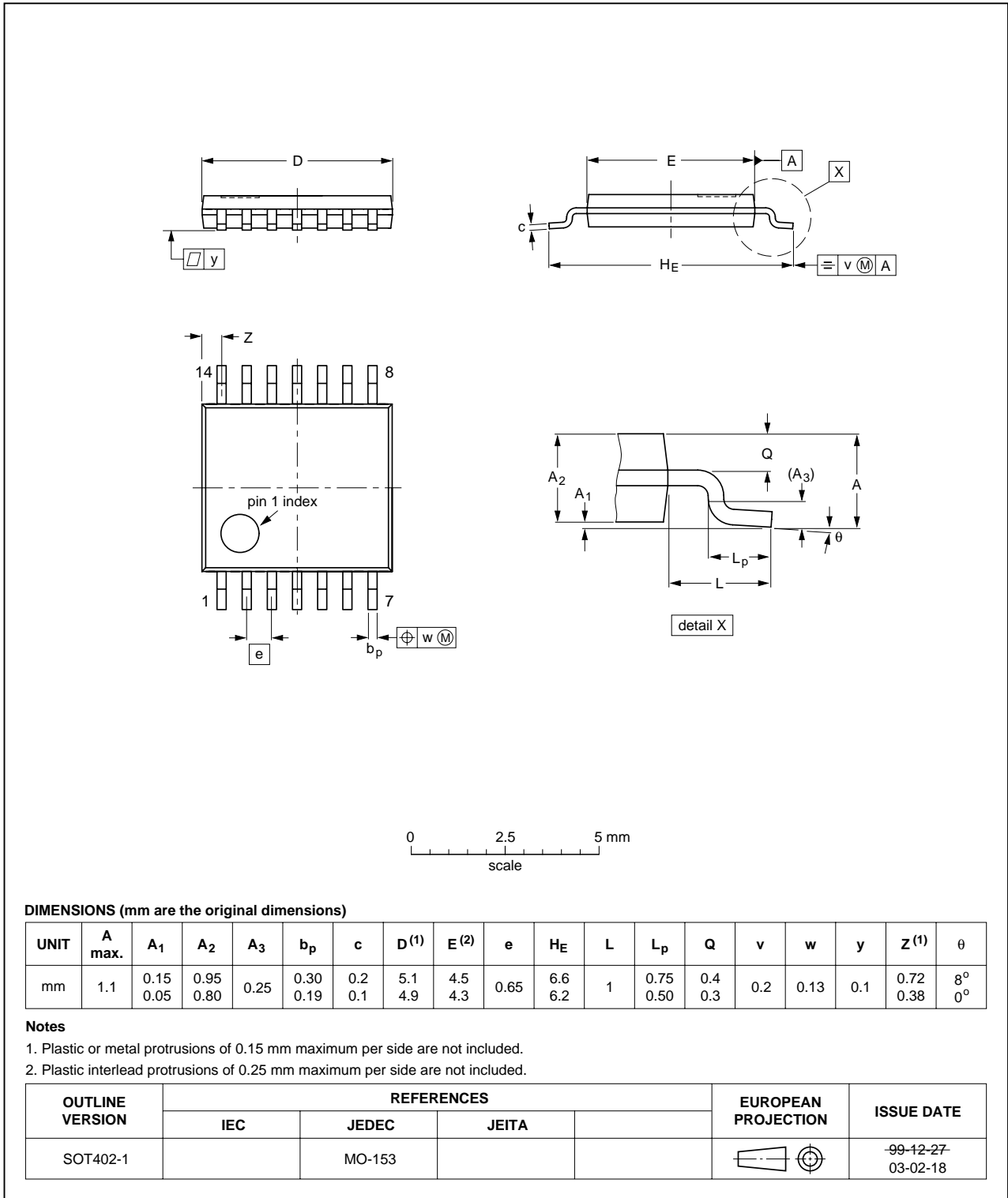

Fig 10. Package outline SOT402-1 (TSSOP14)

DHVQFN14: plastic dual in-line compatible thermal enhanced very thin quad flat package; no leads; 14 terminals; body 2.5 x 3 x 0.85 mm

SOT762-1

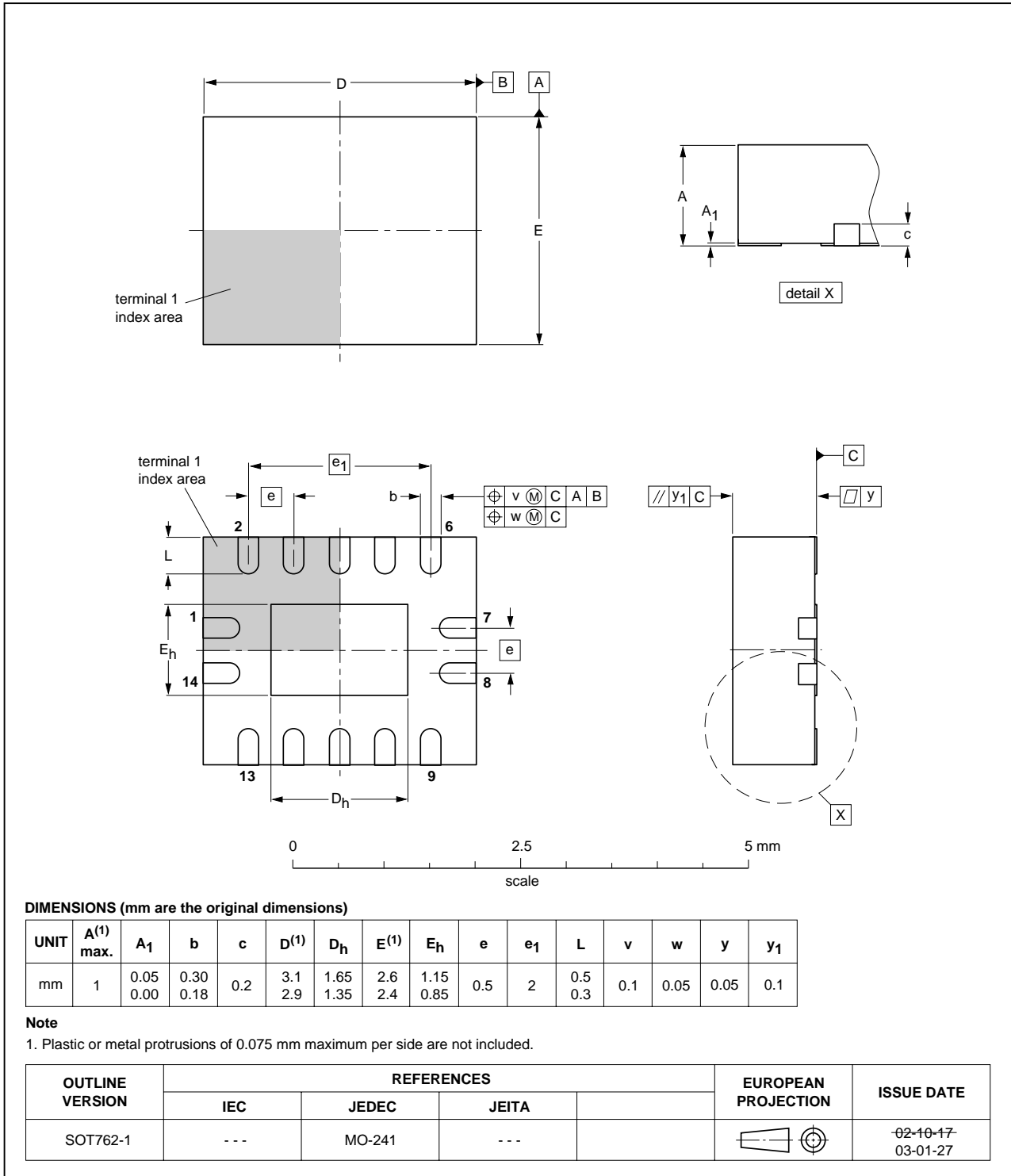

Fig 11. Package outline SOT762-1 (DHVQFN14)

## 13. Abbreviations

Table 10. Abbreviations

Acronym	Description
CDM	Charged-Device Model
DUT	Device Under Test
ESD	ElectroStatic Discharge
HBM	Human Body Model
MM	Machine Model
TTL	Transistor-Transistor Logic

## 14. Revision history

Table 11. Revision history

Document ID	Release date	Data sheet status	Change notice	Supersedes
74ALVC125_2	20080110	Product data sheet	-	74ALVC125_1
Modifications:	<ul style="list-style-type: none"> <li>• The format of this data sheet has been redesigned to comply with the new identity guidelines of NXP Semiconductors.</li> <li>• Legal texts have been adapted to the new company name where appropriate.</li> <li>• <a href="#">Section 3</a>: DHVQFN14 package added.</li> <li>• <a href="#">Section 7</a>: derating values added for DHVQFN14 package.</li> <li>• <a href="#">Section 12</a>: outline drawing added for DHVQFN14 package.</li> </ul>			
74ALVC125_1	20021118	Product specification	-	-

## 15. Legal information

### 15.1 Data sheet status

Document status <sup>[1][2]</sup>	Product status <sup>[3]</sup>	Definition
Objective [short] data sheet	Development	This document contains data from the objective specification for product development.
Preliminary [short] data sheet	Qualification	This document contains data from the preliminary specification.
Product [short] data sheet	Production	This document contains the product specification.

[1] Please consult the most recently issued document before initiating or completing a design.

[2] The term 'short data sheet' is explained in section "Definitions".

[3] The product status of device(s) described in this document may have changed since this document was published and may differ in case of multiple devices. The latest product status information is available on the Internet at URL <http://www.nxp.com>.

### 15.2 Definitions

**Draft** — The document is a draft version only. The content is still under internal review and subject to formal approval, which may result in modifications or additions. NXP Semiconductors does not give any representations or warranties as to the accuracy or completeness of information included herein and shall have no liability for the consequences of use of such information.

**Short data sheet** — A short data sheet is an extract from a full data sheet with the same product type number(s) and title. A short data sheet is intended for quick reference only and should not be relied upon to contain detailed and full information. For detailed and full information see the relevant full data sheet, which is available on request via the local NXP Semiconductors sales office. In case of any inconsistency or conflict with the short data sheet, the full data sheet shall prevail.

### 15.3 Disclaimers

**General** — Information in this document is believed to be accurate and reliable. However, NXP Semiconductors does not give any representations or warranties, expressed or implied, as to the accuracy or completeness of such information and shall have no liability for the consequences of use of such information.

**Right to make changes** — NXP Semiconductors reserves the right to make changes to information published in this document, including without limitation specifications and product descriptions, at any time and without notice. This document supersedes and replaces all information supplied prior to the publication hereof.

**Suitability for use** — NXP Semiconductors products are not designed, authorized or warranted to be suitable for use in medical, military, aircraft, space or life support equipment, nor in applications where failure or

malfunction of an NXP Semiconductors product can reasonably be expected to result in personal injury, death or severe property or environmental damage. NXP Semiconductors accepts no liability for inclusion and/or use of NXP Semiconductors products in such equipment or applications and therefore such inclusion and/or use is at the customer's own risk.

**Applications** — Applications that are described herein for any of these products are for illustrative purposes only. NXP Semiconductors makes no representation or warranty that such applications will be suitable for the specified use without further testing or modification.

**Limiting values** — Stress above one or more limiting values (as defined in the Absolute Maximum Ratings System of IEC 60134) may cause permanent damage to the device. Limiting values are stress ratings only and operation of the device at these or any other conditions above those given in the Characteristics sections of this document is not implied. Exposure to limiting values for extended periods may affect device reliability.

**Terms and conditions of sale** — NXP Semiconductors products are sold subject to the general terms and conditions of commercial sale, as published at <http://www.nxp.com/profile/terms>, including those pertaining to warranty, intellectual property rights infringement and limitation of liability, unless explicitly otherwise agreed to in writing by NXP Semiconductors. In case of any inconsistency or conflict between information in this document and such terms and conditions, the latter will prevail.

**No offer to sell or license** — Nothing in this document may be interpreted or construed as an offer to sell products that is open for acceptance or the grant, conveyance or implication of any license under any copyrights, patents or other industrial or intellectual property rights.

### 15.4 Trademarks

Notice: All referenced brands, product names, service names and trademarks are the property of their respective owners.

## 16. Contact information

For additional information, please visit: <http://www.nxp.com>

For sales office addresses, send an email to: [salesaddresses@nxp.com](mailto:salesaddresses@nxp.com)

**17. Contents**

1 **General description** ..... 1

2 **Features** ..... 1

3 **Ordering information** ..... 1

4 **Functional diagram** ..... 2

5 **Pinning information** ..... 2

5.1 Pinning ..... 2

5.2 Pin description ..... 3

6 **Functional description** ..... 3

7 **Limiting values** ..... 3

8 **Recommended operating conditions** ..... 4

9 **Static characteristics** ..... 4

10 **Dynamic characteristics** ..... 5

11 **Waveforms** ..... 6

12 **Package outline** ..... 8

13 **Abbreviations** ..... 11

14 **Revision history** ..... 11

15 **Legal information** ..... 12

15.1 Data sheet status ..... 12

15.2 Definitions ..... 12

15.3 Disclaimers ..... 12

15.4 Trademarks ..... 12

16 **Contact information** ..... 12

17 **Contents** ..... 13

Please be aware that important notices concerning this document and the product(s) described herein, have been included in section 'Legal information'.



© NXP B.V. 2008.

All rights reserved.

For more information, please visit: <http://www.nxp.com>

For sales office addresses, please send an email to: [salesaddresses@nxp.com](mailto:salesaddresses@nxp.com)

Date of release: 10 January 2008

Document identifier: 74ALVC125\_2



LittleDiode supplies new, hard to find or obsolete electronic components and semiconductors all over the world.

With over two million different components listed you are sure to find the part you need.

Feel free to visit us today at our online store:

[LittleDiode.com](http://LittleDiode.com)

Looking forward to providing you with the best possible service.