

DATA SHEET

74ALVCH162244

16-bit buffer/line driver
with 30 Ω termination resistor (3-State)

Product specification

1998 Jun 29

IC24 Data Handbook

16-bit buffer/line driver with 30Ω termination resistor (3-State)

74ALVCH162244

FEATURES

- Wide supply voltage range of 1.2V to 3.6V
- Complies with JEDEC standard no. 8-1A
- CMOS low power consumption
- MULTIBYTE™ flow-through standard pin-out architecture
- Low inductance multiple V_{CC} and ground pins for minimum noise and ground bounce
- Direct interface with TTL levels
- Bus hold on all data inputs
- Integrated 30Ω termination resistor

DESCRIPTION

The 74ALVCH162244 is a high-performance, low-power, low-voltage, Si-gate CMOS device, superior to most advanced CMOS compatible TTL families.

The 74ALVCH162244 is a 16-bit non-inverting buffer/line driver with 3-State outputs. The device can be used as four 4-bit buffers, two 8-bit buffers or one 16-bit buffer. The 3-State outputs are controlled by the output enable inputs $1\overline{OE}$ and $2\overline{OE}$. A HIGH on $n\overline{OE}$ causes the outputs to assume a high impedance OFF-state. The 74ALVCH162244 is designed with 30Ω series resistors in both HIGH and LOW output states.

The 74ALVCH162244 has active bus hold circuitry which is provided to hold unused or floating data inputs at a valid logic level. This feature eliminates the need for external pull-up or pull-down resistors.

PIN CONFIGURATION

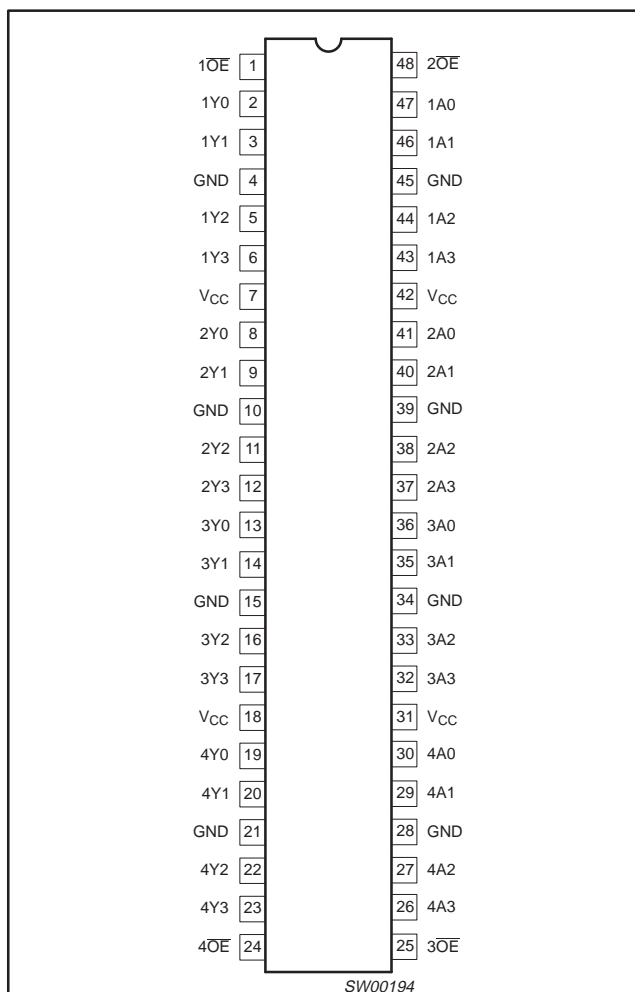

QUICK REFERENCE DATA

GND = 0 V; $T_{amb} = 25^{\circ}\text{C}$; $t_r = t_f \leq 2.5 \text{ ns}$

SYMBOL	PARAMETER	CONDITIONS	TYPICAL	UNIT	
t_{PHL}/t_{PLH}	Propagation delay An to Yn	$V_{CC} = 2.5\text{V}$, $C_L = 30\text{pF}$ $V_{CC} = 3.3\text{V}$, $C_L = 50\text{pF}$	3.0 2.7	ns	
C_I	Input capacitance		5.0	pF	
C_{PD}	Power dissipation capacitance per buffer	$V_I = \text{GND to } V_{CC}^1$	Outputs enabled	25	pF
			Outputs disabled	4	

NOTES:

1. C_{PD} is used to determine the dynamic power dissipation (P_D in μW):

$$P_D = C_{PD} \times V_{CC}^2 \times f_i + \sum (C_L \times V_{CC}^2 \times f_o)$$

where: f_i = input frequency in MHz; C_L = output load capacitance in pF;
 f_o = output frequency in MHz; V_{CC} = supply voltage in V; $\sum (C_L \times V_{CC}^2 \times f_o)$ = sum of the outputs.

ORDERING INFORMATION

PACKAGES	TEMPERATURE RANGE	OUTSIDE NORTH AMERICA	NORTH AMERICA	DWG NUMBER
48-Pin Plastic SSOP Type III	-40°C to +85°C	74ALVCH162244 DL	ACH162244 DL	SOT370-1
48-Pin Plastic TSSOP Type II	-40°C to +85°C	74ALVCH162244 DGG	ACH162244 DGG	SOT362-1

16-bit buffer/line driver with 30Ω termination resistor (3-State)

74ALVCH162244

RECOMMENDED OPERATING CONDITIONS

SYMBOL	PARAMETER	CONDITIONS	LIMITS		UNIT
			MIN	MAX	
V _{CC}	DC supply voltage 2.5V range (for max. speed performance @ 30 pF output load)		2.3	2.7	V
	DC supply voltage 3.3V range (for max. speed performance @ 50 pF output load)		3.0	3.6	
V _I	DC Input voltage range		0	V _{CC}	V
V _O	DC output voltage range		0	V _{CC}	V
T _{amb}	Operating free-air temperature range		-40	+85	°C
t _r , t _f	Input rise and fall times	V _{CC} = 2.3 to 3.0V	0	20	ns/V
		V _{CC} = 3.0 to 3.6V	0	10	

ABSOLUTE MAXIMUM RATINGS

In accordance with the Absolute Maximum Rating System (IEC 134)

Voltages are referenced to GND (ground = 0V)

SYMBOL	PARAMETER	CONDITIONS	RATING	UNIT
V _{CC}	DC supply voltage		-0.5 to +4.6	V
I _{IK}	DC input diode current	V _I < 0	-50	mA
V _I	DC input voltage	For data inputs with bus hold ¹	-0.5 to V _{CC} +0.5	V
		For control pins ¹	-0.5 to +4.6	
I _{OK}	DC output diode current	V _O > V _{CC} or V _O < 0	±50	mA
V _O	DC output voltage	Note 1	-0.5 to V _{CC} +0.5	V
I _O	DC output source or sink current	V _O = 0 to V _{CC}	±50	mA
I _{GND} , I _{CC}	DC V _{CC} or GND current		±100	mA
T _{stg}	Storage temperature range		-65 to +150	°C
P _{TOT}	Power dissipation per package -plastic medium-shrink (SSOP) -plastic thin-medium-shrink (TSSOP)	For temperature range: -40 to +125 °C	850	mW
		above +55°C derate linearly with 11.3 mW/K above +55°C derate linearly with 8 mW/K	600	

NOTE:

- The input and output voltage ratings may be exceeded if the input and output current ratings are observed.

16-bit buffer/line driver with 30Ω termination resistor (3-State)

74ALVCH162244

DC ELECTRICAL CHARACTERISTICS

Over recommended operating conditions. Voltage are referenced to GND (ground = 0 V).

SYMBOL	PARAMETER	TEST CONDITIONS	LIMITS			UNIT
			Temp = -40°C to +85°C			
			MIN	TYP ¹	MAX	
V _{IH}	HIGH level Input voltage	V _{CC} = 2.3 to 2.7V	1.7	1.2		V
		V _{CC} = 2.7 to 3.6V	2.0	1.5		
V _{IL}	LOW level Input voltage	V _{CC} = 2.3 to 2.7V		1.2	0.7	V
		V _{CC} = 2.7 to 3.6V		1.5	0.8	
V _{OH}	HIGH level output voltage	V _{CC} = 2.3 to 3.6V; V _I = V _{IH} or V _{IL} ; I _O = -100μA	V _{CC} - 0.2	V _{CC}		V
		V _{CC} = 2.3V; V _I = V _{IH} or V _{IL} ; I _O = -4mA	V _{CC} - 0.4	V _{CC} - 0.11		
		V _{CC} = 2.3V; V _I = V _{IH} or V _{IL} ; I _O = -6mA	V _{CC} - 0.6	V _{CC} - 0.17		
		V _{CC} = 2.7V; V _I = V _{IH} or V _{IL} ; I _O = -4mA	V _{CC} - 0.5	V _{CC} - 0.09		
		V _{CC} = 2.7V; V _I = V _{IH} or V _{IL} ; I _O = -8mA	V _{CC} - 0.7	V _{CC} - 0.19		
		V _{CC} = 3.0V; V _I = V _{IH} or V _{IL} ; I _O = -6mA	V _{CC} - 0.6	V _{CC} - 0.13		
		V _{CC} = 3.0V; V _I = V _{IH} or V _{IL} ; I _O = -12mA	V _{CC} - 1.0	V _{CC} - 0.27		
V _{OL}	LOW level output voltage	V _{CC} = 2.3 to 3.6V; V _I = V _{IH} or V _{IL} ; I _O = 100μA		GND	0.20	V
		V _{CC} = 2.3V; V _I = V _{IH} or V _{IL} ; I _O = 4mA		0.07	0.40	
		V _{CC} = 2.3V; V _I = V _{IH} or V _{IL} ; I _O = 6mA		0.11	0.55	
		V _{CC} = 2.7V; V _I = V _{IH} or V _{IL} ; I _O = 4mA		0.06	0.40	
		V _{CC} = 2.7V; V _I = V _{IH} or V _{IL} ; I _O = 8mA		0.13	0.60	
		V _{CC} = 3.0V; V _I = V _{IH} or V _{IL} ; I _O = 6mA		0.09	0.55	
		V _{CC} = 3.0V; V _I = V _{IH} or V _{IL} ; I _O = 12mA		0.19	0.80	
I _I	Input leakage current	V _{CC} = 2.3 to 3.6V; V _I = V _{CC} or GND		0.1	5	μA
I _{OZ}	3-State output OFF-state current	V _{CC} = 2.3 to 3.6V; V _I = V _{IH} or V _{IL} ; V _O = V _{CC} or GND		0.1	10	μA
I _{CC}	Quiescent supply current	V _{CC} = 2.3 to 3.6V; V _I = V _{CC} or GND; I _O = 0		0.2	40	μA
ΔI _{CC}	Additional quiescent supply current	V _{CC} = 2.3V to 3.6V; V _I = V _{CC} - 0.6V; I _O = 0		150	750	μA
I _{BHL} ²	Bus hold LOW sustaining current	V _{CC} = 2.3V; V _I = 0.7V	45	-		μA
		V _{CC} = 3.0V; V _I = 0.8V	75	150		
I _{BHH} ²	Bus hold HIGH sustaining current	V _{CC} = 2.3V; V _I = 1.7V	-45			μA
		V _{CC} = 3.0V; V _I = 2.0V	-75	-175		
I _{BHLO} ²	Bus hold LOW overdrive current	V _{CC} = 3.6V	500			μA
I _{BHHO} ²	Bus hold HIGH overdrive current	V _{CC} = 3.6V	-500			μA

NOTES:

1. All typical values are at T_{amb} = 25°C.
2. Valid for data inputs of bus hold parts.

16-bit buffer/line driver with 30Ω termination resistor (3-State)

74ALVCH162244

AC CHARACTERISTICS FOR $V_{CC} = 2.3V$ TO $2.7V$ RANGE AND $V_{CC} < 2.3V$

GND = 0V; $t_r = t_f \leq 2.0ns$; $C_L = 30pF$

SYMBOL	PARAMETER	WAVEFORM	LIMITS			UNIT
			$V_{CC} = 2.3$ to $2.7V$			
			MIN	TYP ¹	MAX	
t_{PHL}/t_{PLH}	Propagation delay nAn to nYn	1, 3	1.0	3.0	4.9	ns
t_{PZH}/t_{PZL}	3-State output enable time nOE to nYn	2, 3	1.0	4.0	6.8	ns
t_{PHZ}/t_{PLZ}	3-State output disable time nOE to nYn	2, 3	1.0	2.3	6.3	ns

NOTES:1. All typical values are measured at $T_{amb} = 25^\circ C$ and $V_{CC} = 2.5V$.

AC CHARACTERISTICS FOR $V_{CC} = 3.0V$ TO $3.6V$ RANGE AND $V_{CC} = 2.7V$

GND = 0V; $t_r = t_f \leq 2.5ns$; $C_L = 50pF$

SYMBOL	PARAMETER	WAVEFORM	LIMITS						UNIT
			$V_{CC} = 3.3 \pm 0.3V$			$V_{CC} = 2.7V$			
			MIN	TYP ^{1, 2}	MAX	MIN	TYP ¹	MAX	
t_{PHL}/t_{PLH}	Propagation delay nAn to nYn	1, 3	1.0	2.7	4.2	1.0	3.3	4.7	ns
t_{PZH}/t_{PZL}	3-State output enable time nOE to nYn	2, 3	1.0	3.5	5.6	1.0	4.6	6.7	ns
t_{PHZ}/t_{PLZ}	3-State output disable time nOE to nYn	2, 3	1.0	2.9	5.5	1.0	3.2	5.7	ns

NOTES:1. All typical values are measured at $T_{amb} = 25^\circ C$.2. Typical value is measured at $V_{CC} = 3.3V$

16-bit buffer/line driver with 30Ω termination resistor (3-State)

74ALVCH162244

AC WAVEFORMS FOR $V_{CC} = 2.3V$ TO $2.7V$ AND $V_{CC} < 2.3V$ RANGE

$V_M = 0.5 V_{CC}$
 $V_X = V_{OL} + 0.15V$
 $V_Y = V_{OH} - 0.15V$
 V_{OL} and V_{OH} are the typical output voltage drop that occur with the output load.
 $V_I = V_{CC}$

AC WAVEFORMS FOR $V_{CC} = 3.0V$ TO $3.6V$ AND $V_{CC} = 2.7V$ RANGE

$V_M = 1.5 V$
 $V_X = V_{OL} + 0.3V$
 $V_Y = V_{OH} - 0.3V$
 V_{OL} and V_{OH} are the typical output voltage drop that occur with the output load.
 $V_I = 2.7V$

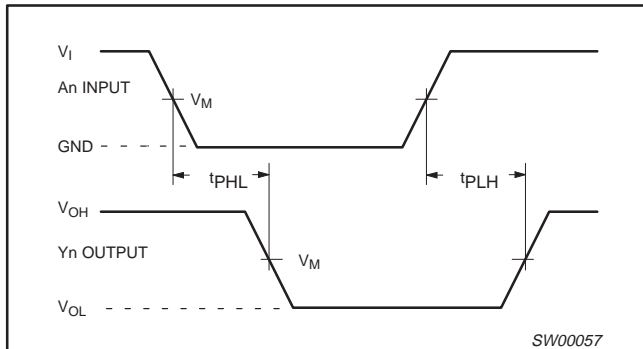

Waveform 1. Input (An) to output (Yn) propagation delay times

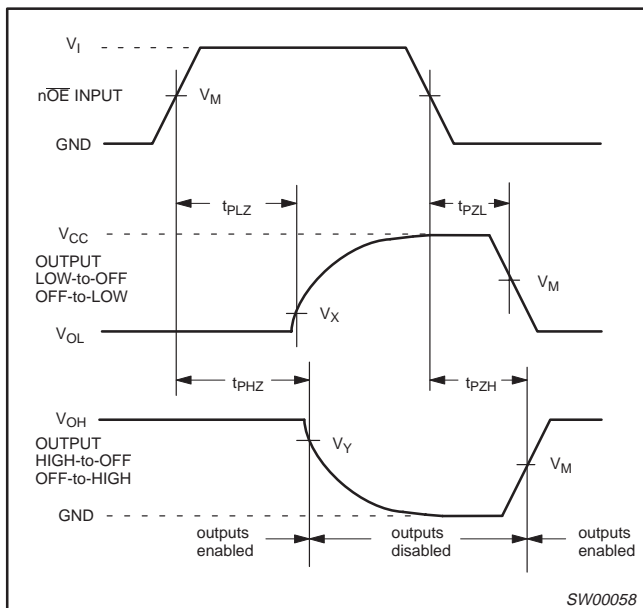

Waveform 2. 3-State enable and disable times

TEST CIRCUIT

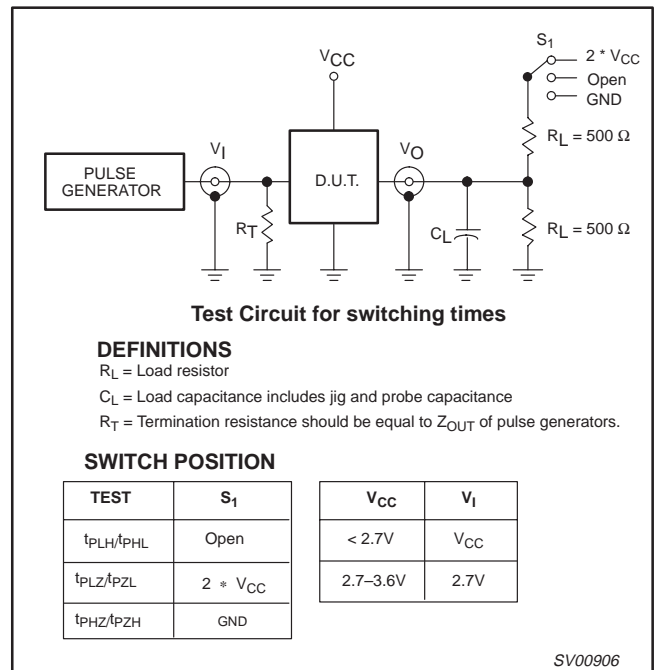

Waveform 3. Load circuitry for switching times

16-bit buffer/line driver with 30Ω termination resistor
(3-State)

74ALVCH162244

SSOP48: plastic shrink small outline package; 48 leads; body width 7.5 mm

SOT370-1

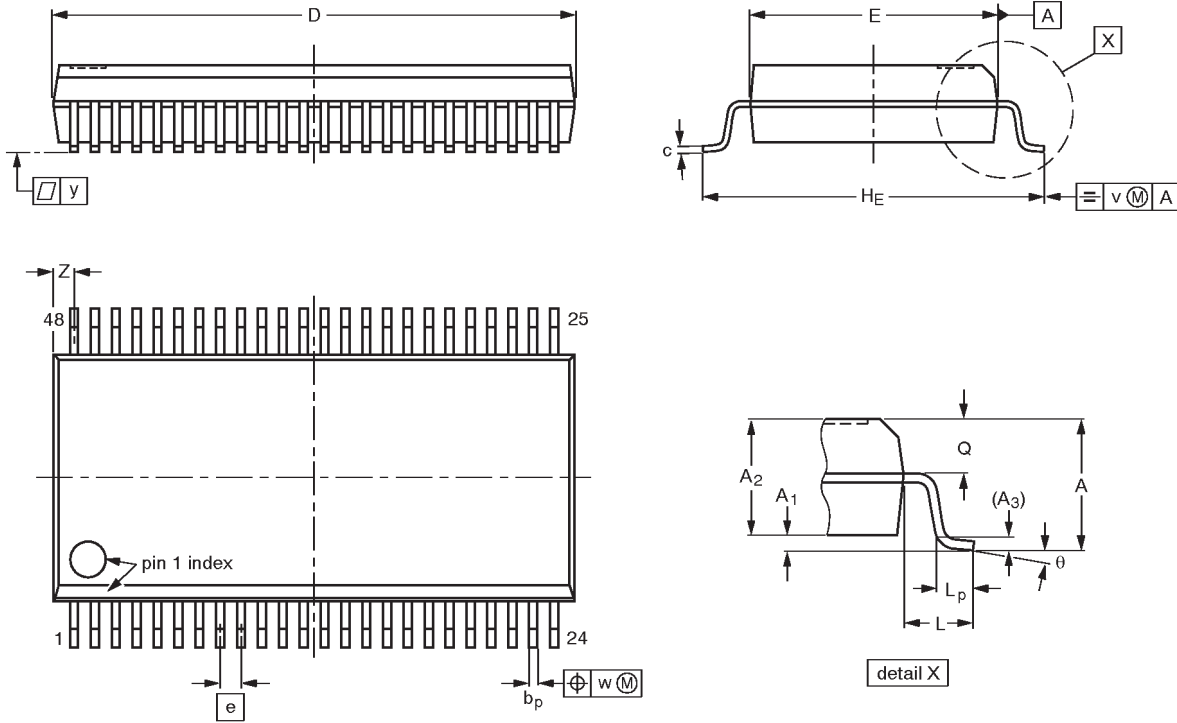

DIMENSIONS (mm are the original dimensions)

UNIT	A max.	A ₁	A ₂	A ₃	b _p	c	D ⁽¹⁾	E ⁽¹⁾	e	H _E	L	L _p	Q	v	w	y	Z ⁽¹⁾	θ
mm	2.8	0.4 0.2	2.35 2.20	0.25	0.3 0.2	0.22 0.13	16.00 15.75	7.6 7.4	0.635	10.4 10.1	1.4	1.0 0.6	1.2 1.0	0.25	0.18	0.1	0.85 0.40	8° 0°

Note

1. Plastic or metal protrusions of 0.25 mm maximum per side are not included.

OUTLINE VERSION	REFERENCES				EUROPEAN PROJECTION	ISSUE DATE
	IEC	JEDEC	EIAJ			
SOT370-1		MO-118AA				93-11-02- 95-02-04

16-bit buffer/line driver with 30Ω termination resistor
(3-State)

74ALVCH162244

TSSOP48: plastic thin shrink small outline package; 48 leads; body width 6.1mm

SOT362-1

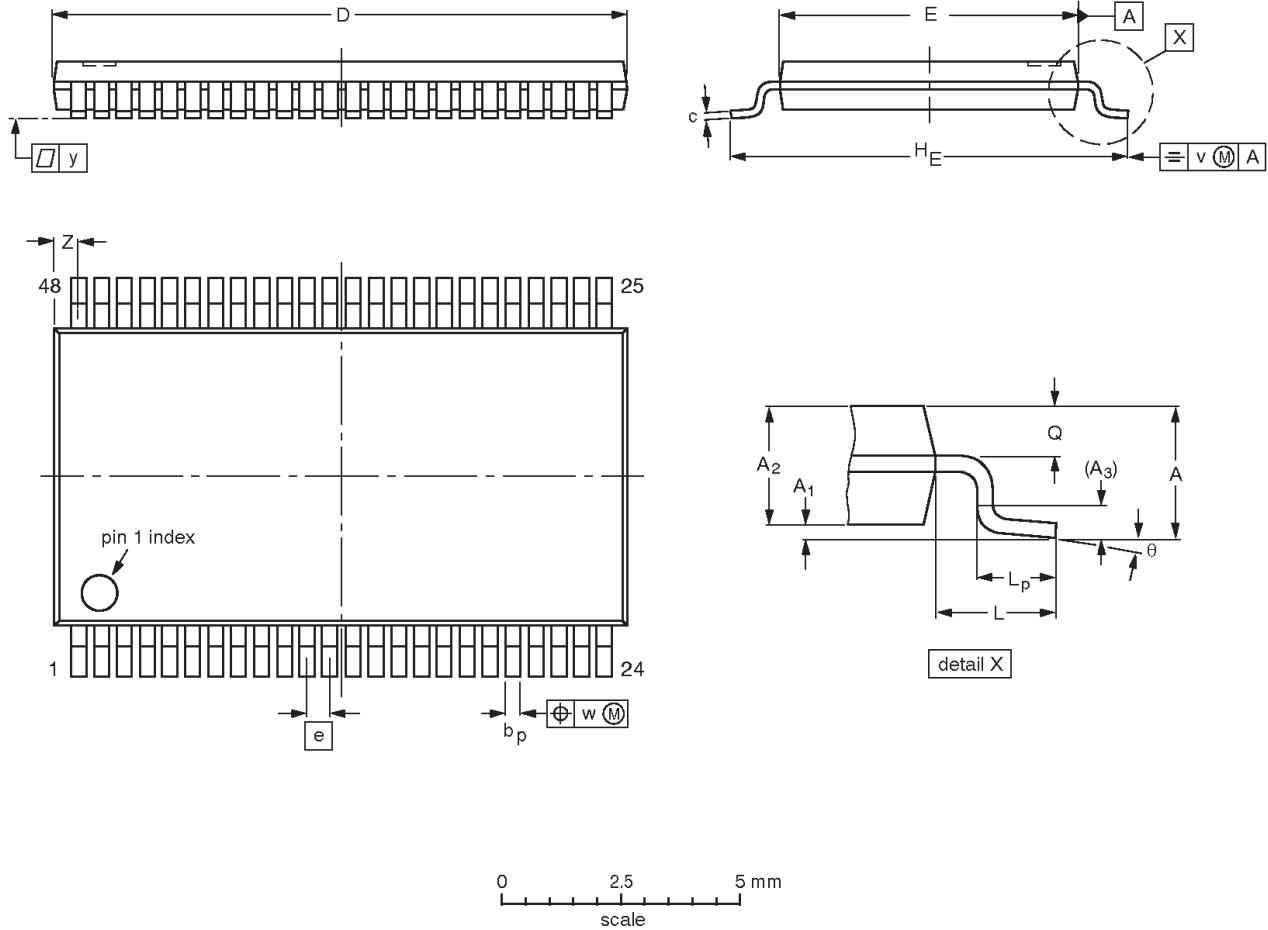

DIMENSIONS (mm are the original dimensions).

UNIT	A max.	A ₁	A ₂	A ₃	b _p	c	D ⁽¹⁾	E ⁽²⁾	e	H _E	L	L _p	Q	v	w	y	Z	θ
mm	1.2	0.15 0.05	1.05 0.85	0.25	0.28 0.17	0.2 0.1	12.6 12.4	6.2 6.0	0.5	8.3 7.9	1	0.8 0.4	0.50 0.35	0.25	0.08	0.1	0.8 0.4	8° 0°

Notes

1. Plastic or metal protrusions of 0.15 mm maximum per side are not included.
2. Plastic interlead protrusions of 0.25 mm maximum per side are not included.

OUTLINE VERSION	REFERENCES				EUROPEAN PROJECTION	ISSUE DATE
	IEC	JEDEC	EIAJ			
SOT362-1		MO-153ED				93-02-03 95-02-10

16-bit buffer/line driver with 30Ω termination resistor
(3-State)

74ALVCH162244

NOTES

16-bit buffer/line driver with 30Ω termination resistor (3-State)

74ALVCH162244

Data sheet status

Data sheet status	Product status	Definition [1]
Objective specification	Development	This data sheet contains the design target or goal specifications for product development. Specification may change in any manner without notice.
Preliminary specification	Qualification	This data sheet contains preliminary data, and supplementary data will be published at a later date. Philips Semiconductors reserves the right to make changes at any time without notice in order to improve design and supply the best possible product.
Product specification	Production	This data sheet contains final specifications. Philips Semiconductors reserves the right to make changes at any time without notice in order to improve design and supply the best possible product.

[1] Please consult the most recently issued datasheet before initiating or completing a design.

Definitions

Short-form specification — The data in a short-form specification is extracted from a full data sheet with the same type number and title. For detailed information see the relevant data sheet or data handbook.

Limiting values definition — Limiting values given are in accordance with the Absolute Maximum Rating System (IEC 134). Stress above one or more of the limiting values may cause permanent damage to the device. These are stress ratings only and operation of the device at these or at any other conditions above those given in the Characteristics sections of the specification is not implied. Exposure to limiting values for extended periods may affect device reliability.

Application information — Applications that are described herein for any of these products are for illustrative purposes only. Philips Semiconductors make no representation or warranty that such applications will be suitable for the specified use without further testing or modification.

Disclaimers

Life support — These products are not designed for use in life support appliances, devices or systems where malfunction of these products can reasonably be expected to result in personal injury. Philips Semiconductors customers using or selling these products for use in such applications do so at their own risk and agree to fully indemnify Philips Semiconductors for any damages resulting from such application.

Right to make changes — Philips Semiconductors reserves the right to make changes, without notice, in the products, including circuits, standard cells, and/or software, described or contained herein in order to improve design and/or performance. Philips Semiconductors assumes no responsibility or liability for the use of any of these products, conveys no license or title under any patent, copyright, or mask work right to these products, and makes no representations or warranties that these products are free from patent, copyright, or mask work right infringement, unless otherwise specified.

Philips Semiconductors
811 East Arques Avenue
P.O. Box 3409
Sunnyvale, California 94088-3409
Telephone 800-234-7381

© Copyright Philips Electronics North America Corporation 1998
All rights reserved. Printed in U.S.A.

Date of release: 06-98

Document order number:

9397-750-04537

Let's make things better.



LittleDiode supplies new, hard to find or obsolete electronic components and semiconductors all over the world.

With over two million different components listed you are sure to find the part you need.

Feel free to visit us today at our online store:

LittleDiode.com

Looking forward to providing you with the best possible service.