

DATA SHEET

74ALVT16652

**2.5V/3.3V 16-bit bus transceiver/register
(3-State)**

Product specification
Supersedes data of 1996 Aug 13
IC23 Data Handbook

1998 Feb 13

2.5V/3.3V 16-bit bus transceiver/register (3-State)

74ALVT16652

FEATURES

- 16-bit bus interface
- 5V I/O Compatible
- 3-State buffers
- Output capability: +64mA/-32mA
- TTL input and output switching levels
- Input and output interface capability to systems at 5V supply
- Bus-hold data inputs eliminate the need for external pull-up resistors to hold unused inputs
- Live insertion/extraction permitted
- Power-up reset
- Power-up 3-State
- No bus current loading when output is tied to 5V bus
- Latch-up protection exceeds 500mA per JEDEC JC40.2 Std 17
- ESD protection exceeds 2000V per MIL STD 883 Method 3015 and 200V per Machine Model

DESCRIPTION

The 74ALVT16652 is a high-performance BiCMOS product designed for V_{CC} operation at 2.5V or 3.3V with I/O compatibility up to 5V. The device can be used as two 8-bit transceivers or one 16-bit transceiver.

Complimentary output-enable (OEAB and \overline{OEBA}) inputs are provided to control the transceiver functions. Select-control (SAB and SBA) inputs are provided to select whether real-time or stored data is transferred. A Low-input level selects real-time data, and a High input level selects stored data. The circuitry used for select control eliminates the typical decoding glitch that occurs in a multiplexer during the transition between stored and real-time data.

Data on the A or B bus, or both, can be stored in the internal flip-flops by Low-to-High transitions at the appropriate clock (CPAB or CPBA) inputs regardless of the levels on the select-control or output-enable inputs. When SAB and SBA are in real-time transfer mode, it is possible to store data without using the internal D-type flip-flops by simultaneously enabling OEAB and OEBA. In this configuration, each output reinforces its input. Thus, when all other data sources to the two sets of bus lines are at high impedance, each set of bus lines remains at its last level configuration.

QUICK REFERENCE DATA

SYMBOL	PARAMETER	CONDITIONS $T_{amb} = 25^{\circ}C$	TYPICAL		UNIT
			2.5V	3.3V	
t_{PLH} t_{PHL}	Propagation delay nAx to nBx or nBx to nAx	$C_L = 50pF$	2.0 2.1	1.5 1.6	ns
C_{IN}	Input capacitance DIR, \overline{OE}	$V_I = 0V$ or V_{CC}	3	3	pF
$C_{I/O}$	I/O pin capacitance	$V_{I/O} = 0V$ or V_{CC}	9	9	pF
I_{CCZ}	Total supply current	Outputs disabled	40	70	μA

ORDERING INFORMATION

PACKAGES	TEMPERATURE RANGE	OUTSIDE NORTH AMERICA	NORTH AMERICA	DWG NUMBER
56-Pin Plastic SSOP Type III	-40°C to +85°C	74ALVT16652 DL	AV16652 DL	SOT371-1
56-Pin Plastic TSSOP Type II	-40°C to +85°C	74ALVT16652 DGG	AV16652 DGG	SOT364-1

LOGIC SYMBOL (IEEE/IEC)

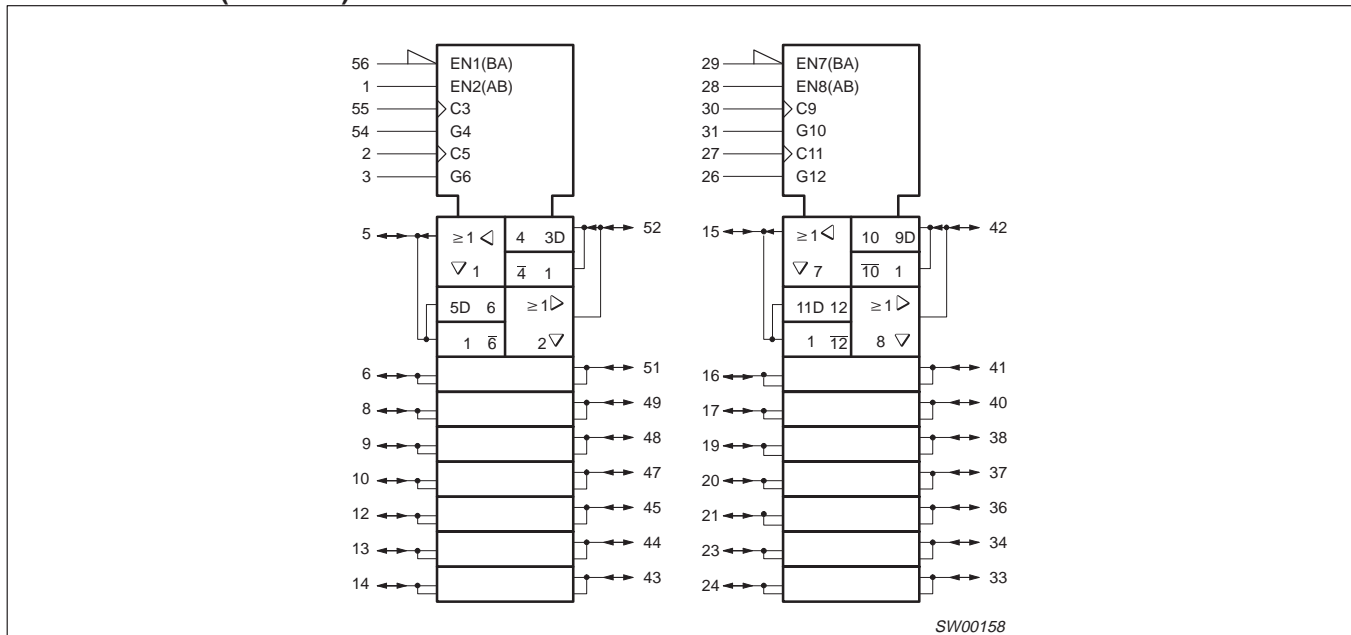

SW00158

2.5V/3.3V 16-bit bus transceiver/register (3-State)

74ALVT16652

PIN CONFIGURATION

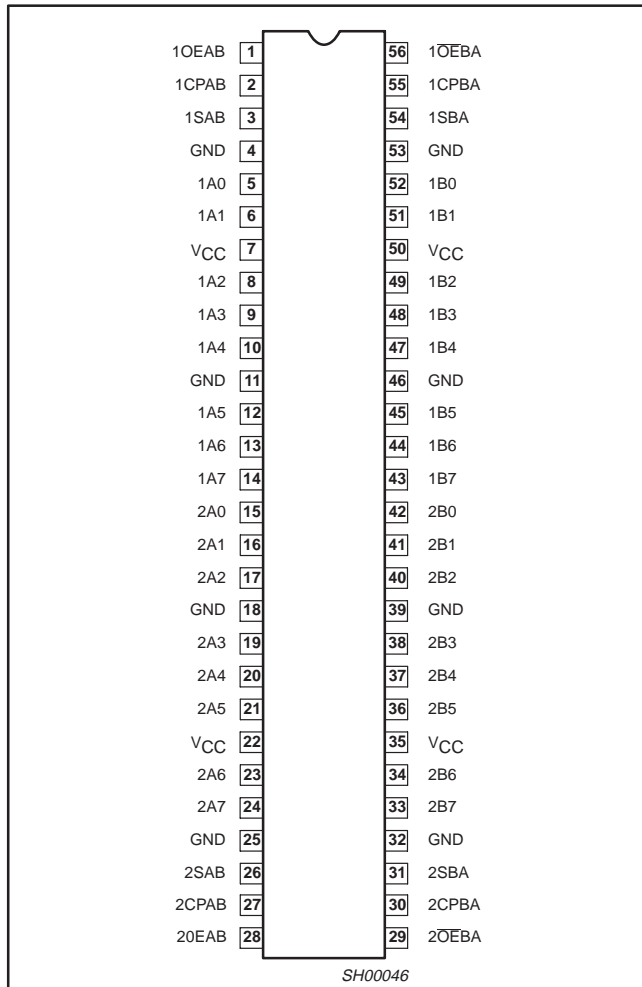

LOGIC SYMBOL

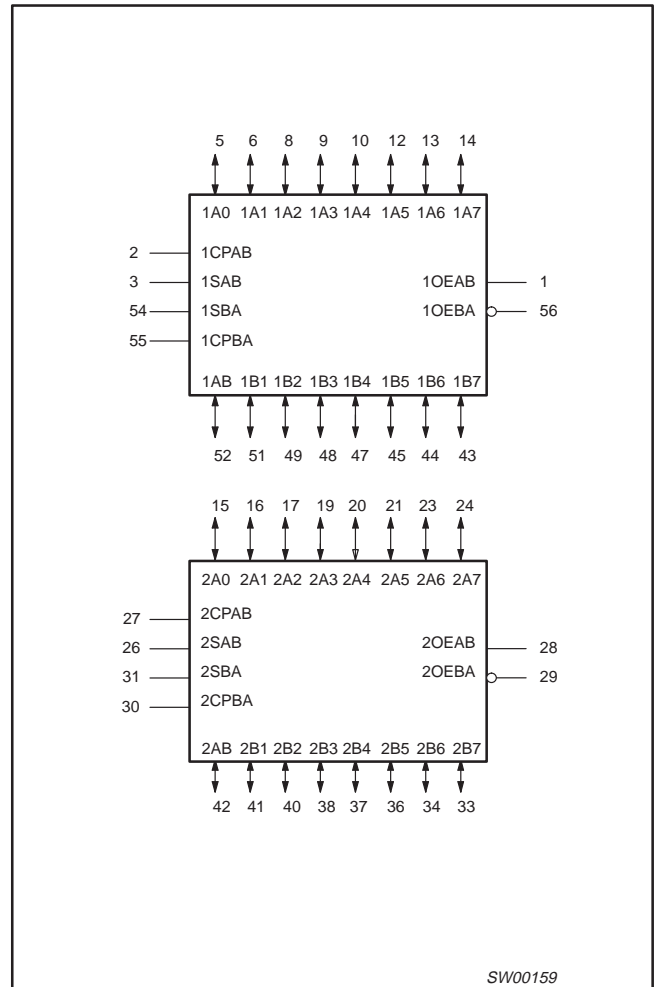

PIN DESCRIPTION

PIN NUMBER	SYMBOL	NAME AND FUNCTION
2, 55, 27, 30	1CPAB, 1CPBA, 2CPAB, 2CPBA	Clock input A to B / Clock input B to A
3, 54, 26, 31	1SAB, 1SBA, 2SAB, 2SBA	Select input A to B / Select input B to A
5, 6, 8, 9, 10, 12, 13, 14 15, 16, 17, 19, 20, 21, 23, 24	1A0 – 1A7, 2A0 – 2A7	Data inputs/outputs (A side)
52, 51, 49, 48, 47, 45, 44, 43 42, 41, 40, 38, 37, 36, 34, 33	1B0 – 1B7, 2B0 – 2B7	Data inputs/outputs (B side)
1, 56, 28, 29	1OEAB, 1OEBA, 2OEAB, 2OEBA	Output enable inputs
4, 11, 18, 25, 32, 39, 46, 53	GND	Ground (0V)
7, 22, 35, 50	V _{CC}	Positive supply voltage

2.5V/3.3V 16-bit bus transceiver/register (3-State)

74ALVT16652

LOGIC DIAGRAM

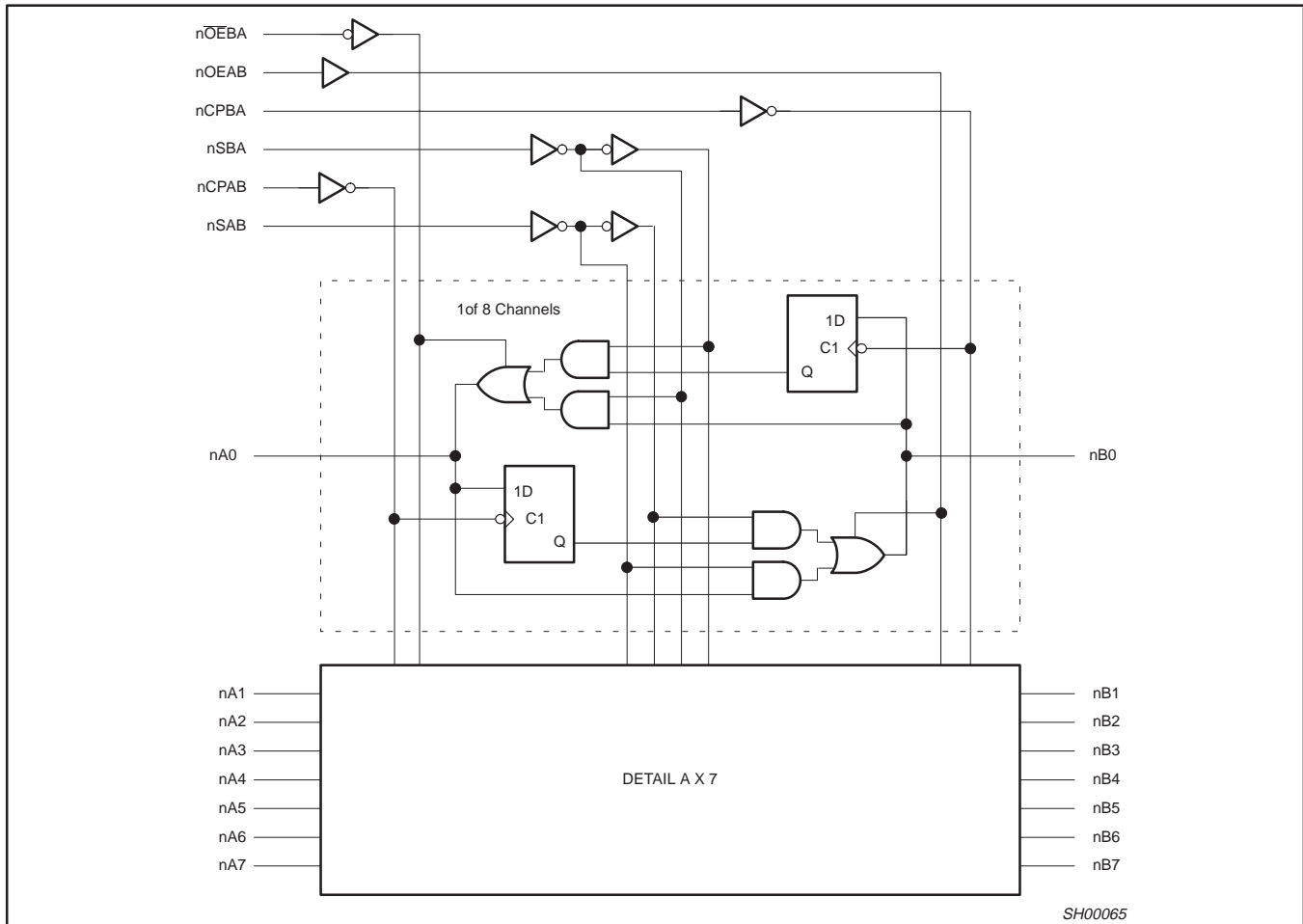

FUNCTION TABLE

INPUTS						DATA I/O		OPERATING MODE
nOEAB	nOEBA	nCPAB	nCPBA	nSAB	nSBA	nAx	nBx	
L	H	H or L	H or L	X	X	Input	Input	Isolation Store A and B data
X	H	↑	H or L	X	X	Input	Unspecified output*	Store A, Hold B Store A in both registers
L	X	H or L	↑	X	X	Unspecified output*	Input	Hold A, Store B Store B in both registers
L	L	X	X	X	L	Output	Input	Real time B data to A bus Stored B data to A bus
H	H	X	X	L	X	Input	Output	Real time A data to B bus Store A data to B bus
H	L	H or L	H or L	H	H	Output	Output	Stored A data to B bus Stored B data to A bus

H = High voltage level

L = Low voltage level

X = Don't care

↑ = Low-to-High clock transition

* The data output function may be enabled or disabled by various signals at the nOEBA and nOEAB inputs. Data input functions are always enabled, i.e., data at the bus pins will be stored on every Low-to-High transition of the clock.

** If both Select controls (nSAB and nSBA) are Low, then clocks can occur simultaneously. If either Select control is High, the clocks must be staggered in order to load both registers.

2.5V/3.3V 16-bit bus transceiver/register (3-State)

74ALVT16652

The following examples demonstrate the four fundamental bus-management functions that can be performed with the 74ALVT16652. The select pins determine whether data is stored or

transferred through the device in real time. The output enable pins determine the direction of the data flow.

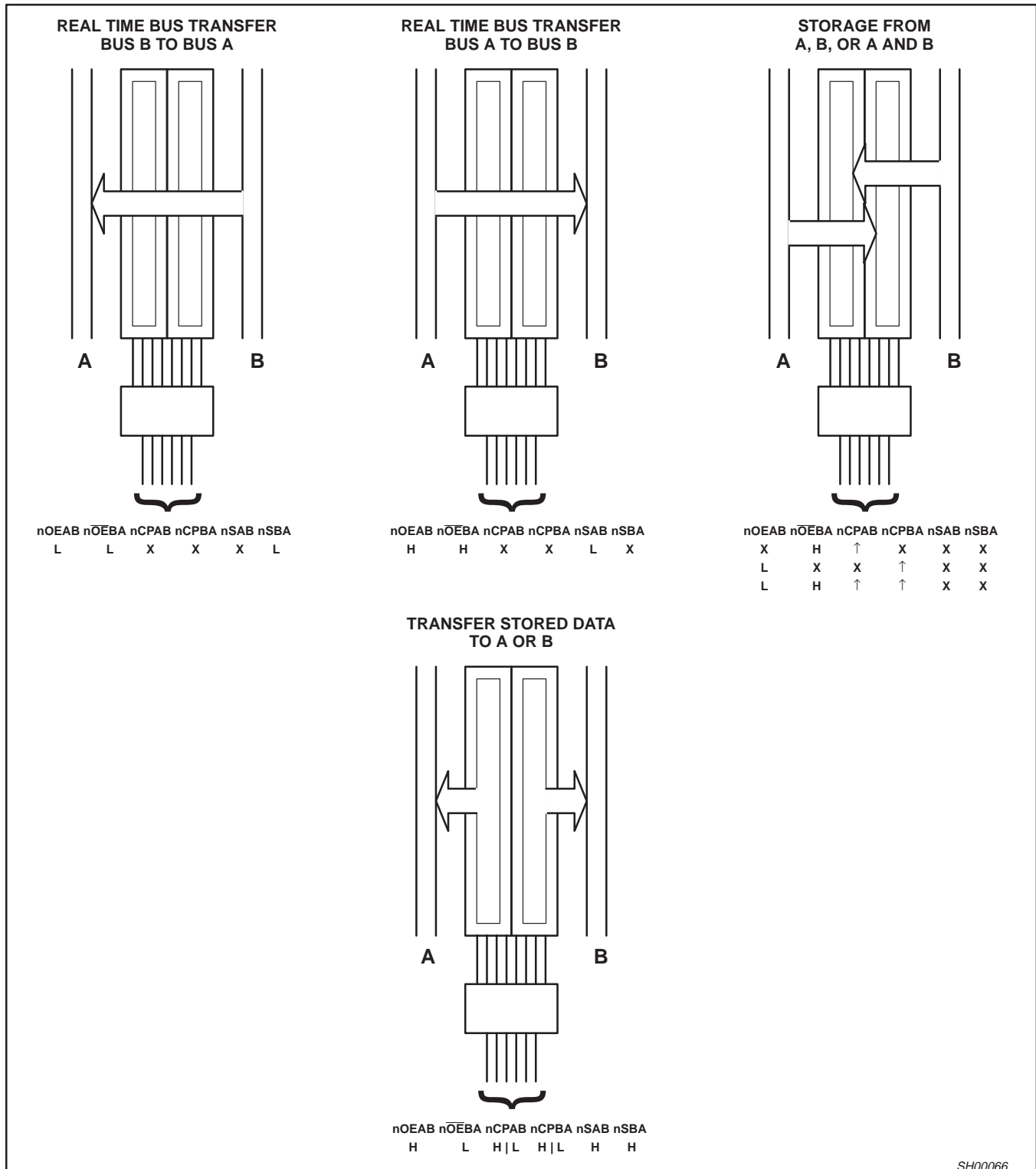

SH00066

2.5V/3.3V 16-bit bus transceiver/register (3-State)

74ALVT16652

ABSOLUTE MAXIMUM RATINGS^{1, 2}

SYMBOL	PARAMETER	CONDITIONS	RATING	UNIT
V _{CC}	DC supply voltage		-0.5 to +4.6	V
I _{IK}	DC input diode current	V _I < 0	-50	mA
V _I	DC input voltage ³		-0.5 to +7.0	V
I _{OK}	DC output diode current	V _O < 0	-50	mA
V _{OUT}	DC output voltage ³	Output in Off or High state	-0.5 to +7.0	V
I _{OUT}	DC output current	Output in Low state	128	mA
		Output in High state	-64	
T _{stg}	Storage temperature range		-65 to +150	°C

NOTES:

- Stresses beyond those listed may cause permanent damage to the device. These are stress ratings only and functional operation of the device at these or any other conditions beyond those indicated under "recommended operating conditions" is not implied. Exposure to absolute-maximum-rated conditions for extended periods may affect device reliability.
- The performance capability of a high-performance integrated circuit in conjunction with its thermal environment can create junction temperatures which are detrimental to reliability. The maximum junction temperature of this integrated circuit should not exceed 150°C.
- The input and output negative voltage ratings may be exceeded if the input and output clamp current ratings are observed.

RECOMMENDED OPERATING CONDITIONS

SYMBOL	PARAMETER	2.5V RANGE LIMITS		3.3V RANGE LIMITS		UNIT
		MIN	MAX	MIN	MAX	
V _{CC}	DC supply voltage	2.3	2.7	3.0	3.6	V
V _I	Input voltage	0	5.5	0	5.5	V
V _{IH}	High-level input voltage	1.7		2.0		V
V _{IL}	Input voltage		0.7		0.8	V
I _{OH}	High-level output current		-8		-32	mA
I _{OL}	Low-level output current		8		32	mA
	Low-level output current; current duty cycle ≤ 50%; f ≥ 1kHz		24		64	
Δt/Δv	Input transition rise or fall rate; Outputs enabled		10		10	ns/V
T _{amb}	Operating free-air temperature range	-40	+85	-40	+85	°C

2.5V/3.3V 16-bit bus transceiver/register (3-State)

74ALVT16652

DC ELECTRICAL CHARACTERISTICS (3.3V ± 0.3V RANGE)

GND = 0V; $t_R = t_F = 2.5\text{ns}$; $C_L = 50\text{pF}$; $R_L = 500\Omega$; $T_{\text{amb}} = -40^\circ\text{C}$ to $+85^\circ\text{C}$.

SYMBOL	PARAMETER	TEST CONDITIONS	LIMITS			UNIT
			Temp = -40°C to $+85^\circ\text{C}$			
			MIN	TYP ¹	MAX	
V_{IK}	Input clamp voltage	$V_{CC} = 3.0\text{V}$; $I_{IK} = -18\text{mA}$		-0.85	-1.2	V
V_{OH}	High-level output voltage	$V_{CC} = 3.0$ to 3.6V ; $I_{OH} = -100\mu\text{A}$	$V_{CC}-0.2$	V_{CC}		V
		$V_{CC} = 3.0\text{V}$; $I_{OH} = -32\text{mA}$	2.0	2.3		
V_{OL}	Low-level output voltage	$V_{CC} = 3.0\text{V}$; $I_{OL} = 100\mu\text{A}$		0.07	0.2	V
		$V_{CC} = 3.0\text{V}$; $I_{OL} = 16\text{mA}$		0.25	0.4	
		$V_{CC} = 3.0\text{V}$; $I_{OL} = 32\text{mA}$		0.3	0.5	
		$V_{CC} = 3.0\text{V}$; $I_{OL} = 64\text{mA}$		0.4	0.55	
V_{RST}	Power-up output low voltage ⁶	$V_{CC} = 3.6\text{V}$; $I_O = 1\text{mA}$; $V_I = V_{CC}$ or GND			0.55	V
I_I	Input leakage current	$V_{CC} = 3.6\text{V}$; $V_I = V_{CC}$ or GND	Control pins	0.1	± 1	μA
		$V_{CC} = 0$ or 3.6V ; $V_I = 5.5\text{V}$		0.1	10	
		$V_{CC} = 3.6\text{V}$; $V_I = 5.5\text{V}$	I/O Data pins ⁴	0.1	20	
		$V_{CC} = 3.6\text{V}$; $V_I = V_{CC}$		0.5	10	
		$V_{CC} = 3.6\text{V}$; $V_I = 0$		0.1	-5	
I_{OFF}	Off current	$V_{CC} = 0\text{V}$; V_I or $V_O = 0$ to 4.5V		0.1	± 100	μA
I_{HOLD}	Bus Hold current Data inputs ⁷	$V_{CC} = 3\text{V}$; $V_I = 0.8\text{V}$	75	130		μA
		$V_{CC} = 3\text{V}$; $V_I = 2.0\text{V}$	-75	-140		μA
		$V_{CC} = 3.0\text{V}$; $V_I = 0\text{V}$ to 3.6V	± 500			μA
I_{EX}	Current into an output in the High state when $V_O > V_{CC}$	$V_O = 5.5\text{V}$; $V_{CC} = 3.0\text{V}$		50	125	μA
$I_{PU/PD}$	Power up/down 3-State output current ³	$V_{CC} \leq 1.2\text{V}$; $V_O = 0.5\text{V}$ to V_{CC} ; $V_I = \text{GND}$ or V_{CC} OE/OE = Don't care		40	± 100	μA
I_{CCH}	Quiescent supply current	$V_{CC} = 3.6\text{V}$; Outputs High, $V_I = \text{GND}$ or V_{CC} , $I_O = 0$		0.07	0.14	mA
I_{CCL}		$V_{CC} = 3.6\text{V}$; Outputs Low, $V_I = \text{GND}$ or V_{CC} , $I_O = 0$		3.2	7	
I_{CCZ}		$V_{CC} = 3.6\text{V}$; Outputs Disabled; $V_I = \text{GND}$ or V_{CC} , $I_O = 0^5$		0.07	0.14	
ΔI_{CC}	Additional supply current per input pin ²	$V_{CC} = 3\text{V}$ to 3.6V ; One input at $V_{CC}-0.6\text{V}$, Other inputs at V_{CC} or GND		0.04	0.4	mA

NOTES:

- All typical values are at $V_{CC} = 3.3\text{V}$ and $T_{\text{amb}} = 25^\circ\text{C}$.
- This is the increase in supply current for each input at the specified voltage level other than V_{CC} or GND
- This parameter is valid for any V_{CC} between 0V and 1.2V with a transition time of up to 10msec. From $V_{CC} = 1.2\text{V}$ to $V_{CC} = 3.3\text{V} \pm 0.3\text{V}$ a transition time of 100 μsec is permitted. This parameter is valid for $T_{\text{amb}} = 25^\circ\text{C}$ only.
- Unused pins at V_{CC} or GND.
- I_{CCZ} is measured with outputs pulled up to V_{CC} or pulled down to ground.
- For valid test results, data must not be loaded into the flip-flops (or latches) after applying power.
- This is the bus hold overdrive current required to force the input to the opposite logic state.

2.5V/3.3V 16-bit bus transceiver/register (3-State)

74ALVT16652

AC CHARACTERISTICS (3.3V ± 0.3V RANGE)

GND = 0V; $t_R = t_F = 2.5\text{ns}$; $C_L = 50\text{pF}$; $R_L = 500\Omega$; $T_{\text{amb}} = -40^\circ\text{C}$ to $+85^\circ\text{C}$.

SYMBOL	PARAMETER	WAVEFORM	LIMITS			UNIT
			$V_{CC} = 3.3V \pm 0.3V$			
			MIN	TYP ¹	MAX	
f_{MAX}	Maximum clock frequency	1	150	300		MHz
t_{PLH} t_{PHL}	Propagation delay nCPAB to nBx or nCPBA to nAx	1	1.0 1.0	2.4 2.1	3.6 3.2	ns
t_{PLH} t_{PHL}	Propagation delay nAx to nBx or nBx to nAx	2	0.5 0.5	1.5 1.6	2.5 2.7	ns
t_{PLH} t_{PHL}	Propagation delay nSAB to nBx or nSBA to nAx	3	0.5 0.5	2.4 2.1	3.9 3.9	ns
t_{PZH} t_{PZL}	Output enable time nOEBA to nAx	5 6	0.5 0.5	2.3 1.5	3.6 2.5	ns
t_{PHZ} t_{PLZ}	Output disable time nOEBA to nAx	5 6	1.5 1.0	3.4 2.6	5.0 3.8	ns
t_{PZH} t_{PZL}	Output enable time nOEAB to nBx	5 6	0.5 0.5	2.4 1.7	3.6 2.6	ns
t_{PHZ} t_{PLZ}	Output disable time nOEAB to nBx	5 6	1.5 1.5	3.8 3.1	5.8 4.5	ns

NOTE:

1. All typical values are at $V_{CC} = 3.3V$ and $T_{\text{amb}} = 25^\circ\text{C}$.

AC SETUP REQUIREMENTS (3.3V ± 0.3V RANGE)

GND = 0V, $t_R = 2.5\text{ns}$, $t_F = 2.5\text{ns}$, $C_L = 50\text{pF}$, $R_L = 500\Omega$, $T_{\text{amb}} = -40^\circ\text{C}$ to $+85^\circ\text{C}$

SYMBOL	PARAMETER	WAVEFORM	LIMITS		UNIT
			$V_{CC} = 3.3V \pm 0.3V$		
			MIN	TYP	
$t_s(\text{H})$ $t_s(\text{L})$	Setup time nAx to nCPAB, nBx to nCPBA	4	1.6 1.6	0.8 0.6	ns
$t_h(\text{H})$ $t_h(\text{L})$	Hold time nAx to nCPAB, nBx to nCPBA	4	0.5 0	-0.5 -0.8	ns
$t_w(\text{H})$ $t_w(\text{L})$	Pulse width, High or Low nCPAB or nCPBA	1	1.5 1.5		ns

2.5V/3.3V 16-bit bus transceiver/register (3-State)

74ALVT16652

DC ELECTRICAL CHARACTERISTICS (2.5V ± 0.2V RANGE)

GND = 0V; $t_R = t_F = 2.5\text{ns}$; $C_L = 50\text{pF}$; $R_L = 500\Omega$; $T_{\text{amb}} = -40^\circ\text{C}$ to $+85^\circ\text{C}$.

SYMBOL	PARAMETER	TEST CONDITIONS	LIMITS			UNIT
			Temp = -40°C to $+85^\circ\text{C}$			
			MIN	TYP ¹	MAX	
V_{IK}	Input clamp voltage	$V_{CC} = 2.3\text{V}$; $I_{IK} = -18\text{mA}$		-0.85	-1.2	V
V_{OH}	High-level output voltage	$V_{CC} = 2.3$ to 3.6V ; $I_{OH} = -100\mu\text{A}$	$V_{CC}-0.2$	V_{CC}		V
		$V_{CC} = 2.3\text{V}$; $I_{OH} = -8\text{mA}$	1.8	2.1		
V_{OL}	Low-level output voltage	$V_{CC} = 2.3\text{V}$; $I_{OL} = 100\mu\text{A}$		0.07	0.2	V
		$V_{CC} = 2.3\text{V}$; $I_{OL} = 24\text{mA}$		0.3	0.5	
		$V_{CC} = 2.3\text{V}$; $I_{OL} = 8\text{mA}$			0.4	
V_{RST}	Power-up output low voltage ⁷	$V_{CC} = 2.7\text{V}$; $I_O = 1\text{mA}$; $V_I = V_{CC}$ or GND			0.55	V
I_I	Input leakage current	$V_{CC} = 2.7\text{V}$; $V_I = \text{GND}$	Control pins	0.1	±1	μA
		$V_{CC} = 0$ or 2.7V ; $V_I = 5.5\text{V}$		0.1	10	
		$V_{CC} = 2.7\text{V}$; $V_I = 5.5\text{V}$	I/O Data pins ⁴	0.1	20	
		$V_{CC} = 2.7\text{V}$; $V_I = V_{CC}$		0.1	10	
		$V_{CC} = 2.7\text{V}$; $V_I = 0$		0.1	-5	
I_{OFF}	Off current	$V_{CC} = 0\text{V}$; V_I or $V_O = 0$ to 4.5V		0.1	±100	μA
I_{HOLD}	Bus Hold current A or B inputs ⁶	$V_{CC} = 2.3\text{V}$; $V_I = 0.7\text{V}$		90		μA
		$V_{CC} = 2.3\text{V}$; $V_I = 1.7\text{V}$		-10		μA
I_{EX}	Current into an output in the High state when $V_O > V_{CC}$	$V_O = 5.5\text{V}$; $V_{CC} = 2.3\text{V}$		50	125	μA
$I_{PU/PD}$	Power up/down 3-State output current ³	$V_{CC} \leq 1.2\text{V}$; $V_O = 0.5\text{V}$ to V_{CC} ; $V_I = \text{GND}$ or V_{CC} OE/OE = Don't care		40	100	μA
I_{CCH}	Quiescent supply current	$V_{CC} = 2.7\text{V}$; Outputs High, $V_I = \text{GND}$ or V_{CC} , $I_O = 0$		0.04	0.1	mA
I_{CCL}		$V_{CC} = 2.7\text{V}$; Outputs Low, $V_I = \text{GND}$ or V_{CC} , $I_O = 0$		2.5	4.5	
I_{CCZ}		$V_{CC} = 2.7\text{V}$; Outputs Disabled; $V_I = \text{GND}$ or V_{CC} , $I_O = 0^5$		0.04	0.1	
ΔI_{CC}	Additional supply current per input pin ²	$V_{CC} = 2.3\text{V}$ to 2.7V ; One input at $V_{CC}-0.6\text{V}$, Other inputs at V_{CC} or GND		0.01	0.4	mA

NOTES:

- All typical values are at $V_{CC} = 2.5\text{V}$ and $T_{\text{amb}} = 25^\circ\text{C}$.
- This is the increase in supply current for each input at the specified voltage level other than V_{CC} or GND
- This parameter is valid for any V_{CC} between 0V and 1.2V with a transition time of up to 10msec. From $V_{CC} = 1.2\text{V}$ to $V_{CC} = 2.5\text{V} \pm 0.2\text{V}$ a transition time of 100μsec is permitted. This parameter is valid for $T_{\text{amb}} = 25^\circ\text{C}$ only.
- Unused pins at V_{CC} or GND.
- I_{CCZ} is measured with outputs pulled up to V_{CC} or pulled down to ground.
- Not guaranteed.
- For valid test results, data must not be loaded into the flip-flops (or latches) after applying power.

2.5V/3.3V 16-bit bus transceiver/register (3-State)

74ALVT16652

AC CHARACTERISTICS (2.5V ± 0.2V RANGE)

GND = 0V; $t_R = t_F = 2.5\text{ns}$; $C_L = 50\text{pF}$; $R_L = 500\Omega$; $T_{\text{amb}} = -40^\circ\text{C}$ to $+85^\circ\text{C}$.

SYMBOL	PARAMETER	WAVEFORM	LIMITS			UNIT
			$V_{CC} = 2.5V \pm 0.2V$			
			MIN	TYP ¹	MAX	
f_{MAX}	Maximum clock frequency	1	150	200		MHz
t_{PLH} t_{PHL}	Propagation delay nCPAB to nBx or nCPBA to nAx	1	1.0 1.0	3.0 2.7	4.9 4.2	ns
t_{PLH} t_{PHL}	Propagation delay nAx to nBx or nBx to nAx	2	0.5 0.5	2.0 2.1	3.2 3.5	ns
t_{PLH} t_{PHL}	Propagation delay nSAB to nBx or nSBA to nAx	3	1.5 1.5	3.4 3.2	5.2 5.8	ns
t_{PZH} t_{PZL}	Output enable time nOEBA to nAx	5 6	1.5 0.5	3.2 2.0	4.7 3.2	ns
t_{PHZ} t_{PLZ}	Output disable time nOEBA to nAx	5 6	1.5 1.8	3.2 2.3	4.8 3.5	ns
t_{PZH} t_{PZL}	Output enable time nOEAB to nBx	5 6	1.5 1.0	3.3 2.5	4.9 3.6	ns
t_{PHZ} t_{PLZ}	Output disable time nOEAB to nBx	5 6	2.0 1.0	3.9 2.3	5.9 6.0	ns

NOTE:

1. All typical values are at $V_{CC} = 3.3V$ and $T_{\text{amb}} = 25^\circ\text{C}$.

AC SETUP REQUIREMENTS (2.5V ± 0.2V RANGE)

GND = 0V, $t_R = 2.5\text{ns}$, $t_F = 2.5\text{ns}$, $C_L = 50\text{pF}$, $R_L = 500\Omega$, $T_{\text{amb}} = -40^\circ\text{C}$ to $+85^\circ\text{C}$

SYMBOL	PARAMETER	WAVEFORM	LIMITS		UNIT
			$V_{CC} = 2.5V \pm 0.2V$		
			MIN	TYP	
$t_s(H)$ $t_s(L)$	Setup time ¹ nAx to nCPAB, nBx to nCPBA	4	1.8 2.0	0.9 1.0	ns
$t_h(H)$ $t_h(L)$	Hold time ¹ nAx to nCPAB, nBx to nCPBA	4	0.0 0.0	-1.0 -1.0	ns
$t_w(H)$ $t_w(L)$	Pulse width, High or Low nCPAB or nCPBA	1	1.5 1.5		ns

NOTE:

1. This data sheet limit may vary among suppliers.

AC WAVEFORMS

$V_M = 1.5V$ at $V_{CC} \geq 3.0V$; $V_M = V_{CC}/2$ at $V_{CC} \leq 2.7V$
 $V_X = V_{OL} + 0.3V$ at $V_{CC} \geq 3.0V$; $V_X = V_{OL} + 0.15V$ at $V_{CC} \leq 2.7V$
 $V_Y = V_{OH} - 0.3V$ at $V_{CC} \geq 3.0V$; $V_Y = V_{OH} - 0.15V$ at $V_{CC} \leq 2.7V$

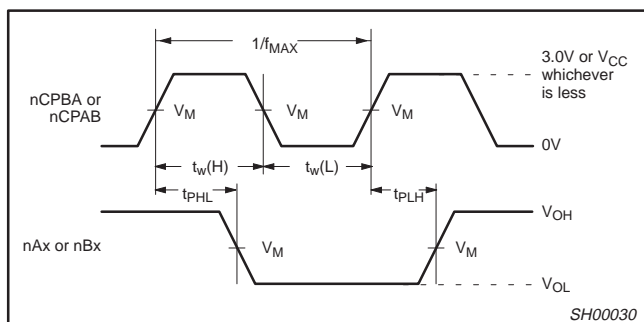

Waveform 1. Propagation Delay, Clock Input to Output, Clock Pulse Width, and Maximum Clock Frequency

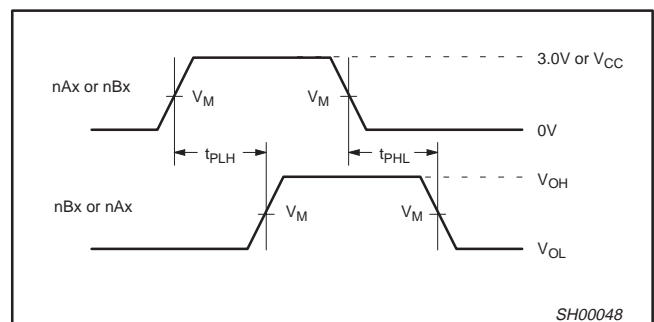

Waveform 2. Propagation Delay, nAx to nBx or nBx to nAx

2.5V/3.3V 16-bit bus transceiver/register (3-State)

74ALVT16652

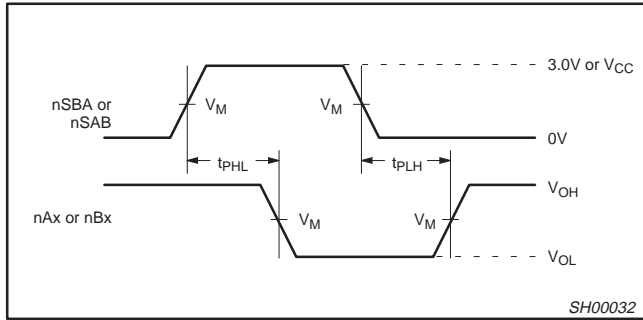

Waveform 3. Propagation Delay, SBA to nAx or SAB to nBx

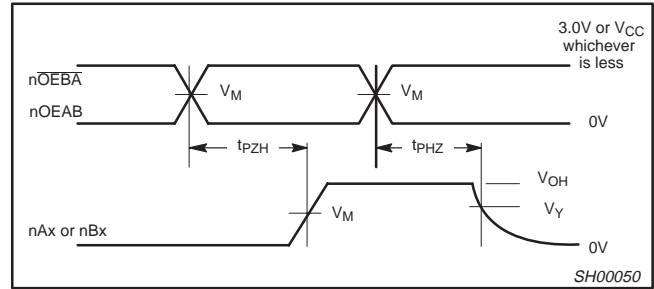

Waveform 5. 3-State Output Enable Time to High Level and Output Disable Time from High Level

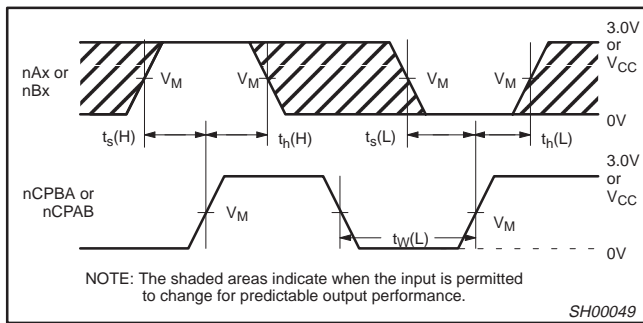

Waveform 4. Data Setup and Hold Times

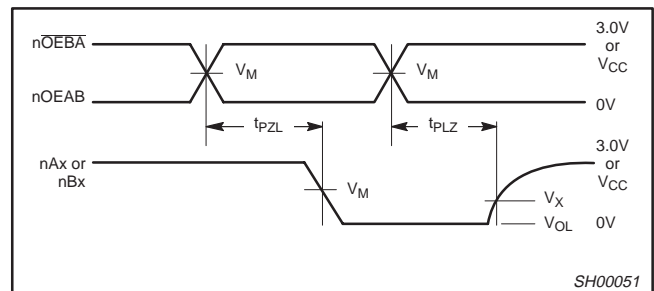

Waveform 6. 3-State Output Enable Time to Low Level and Output Disable Time from Low Level

TEST CIRCUIT AND WAVEFORMS

Test Circuit for 3-State Outputs

SWITCH POSITION

TEST	SWITCH
t_{PLZ}/t_{PZL}	6V or $V_{CC} \times 2$
t_{PLH}/t_{PHL}	Open
t_{PHZ}/t_{PZH}	GND

DEFINITIONS

R_L = Load resistor; see AC CHARACTERISTICS for value.

C_L = Load capacitance includes jig and probe capacitance: See AC CHARACTERISTICS for value.

R_T = Termination resistance should be equal to Z_{OUT} of pulse generators.

SW00025

FAMILY	INPUT PULSE REQUIREMENTS				
	Amplitude	Rep. Rate	t_W	t_R	t_F
74ALVT16	3.0V or V_{CC} whichever is less	$\leq 10\text{MHz}$	500ns	$\leq 2.5\text{ns}$	$\leq 2.5\text{ns}$

2.5V/3.3V 16-bit bus transceiver/register (3-State)

74ALVT16652

SSOP56: plastic shrink small outline package; 56 leads; body width 7.5 mm

SOT371-1

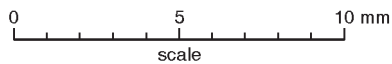
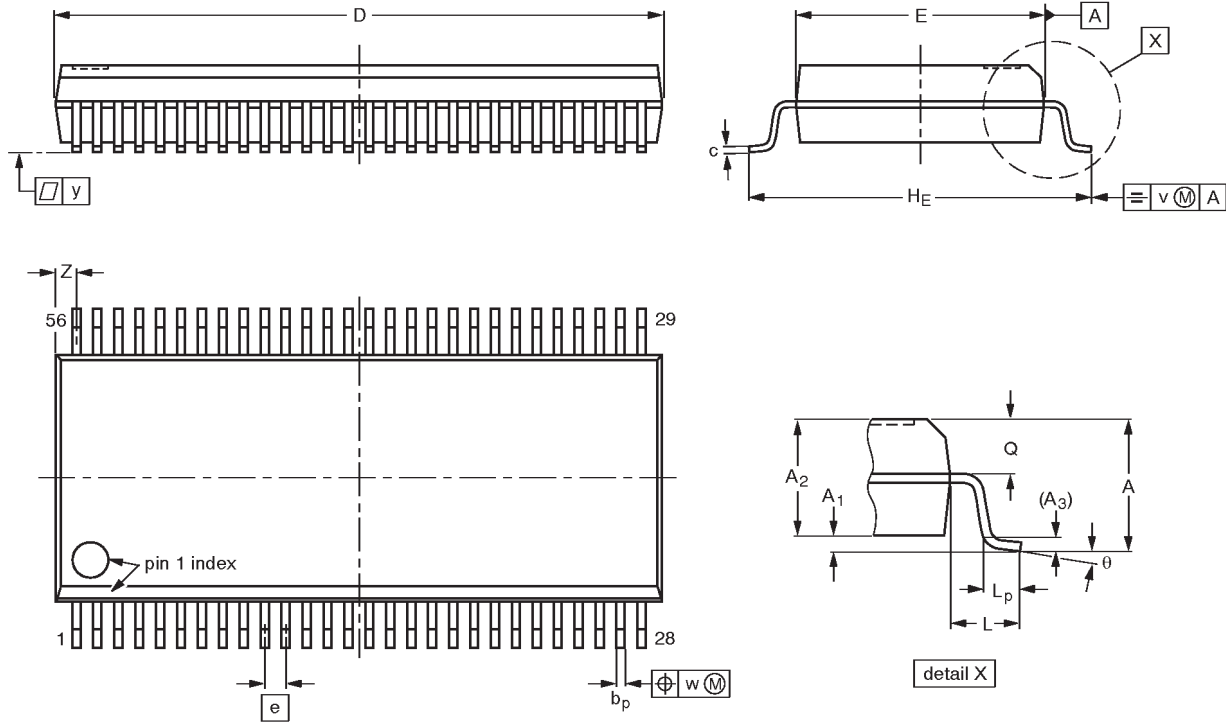

DIMENSIONS (mm are the original dimensions)

UNIT	A max.	A ₁	A ₂	A ₃	b _p	c	D ⁽¹⁾	E ⁽¹⁾	e	H _E	L	L _p	Q	v	w	y	Z ⁽¹⁾	θ
mm	2.8	0.4 0.2	2.35 2.20	0.25	0.3 0.2	0.22 0.13	18.55 18.30	7.6 7.4	0.635	10.4 10.1	1.4	1.0 0.6	1.2 1.0	0.25	0.18	0.1	0.85 0.40	8° 0°

Note

1. Plastic or metal protrusions of 0.25 mm maximum per side are not included.

OUTLINE VERSION	REFERENCES				EUROPEAN PROJECTION	ISSUE DATE
	IEC	JEDEC	EIAJ			
SOT371-1		MO-118AB				93-11-02 95-02-04

2.5V/3.3V 16-bit bus transceiver/register (3-State)

74ALVT16652

TSSOP56: plastic thin shrink small outline package; 56 leads; body width 6.1mm

SOT364-1

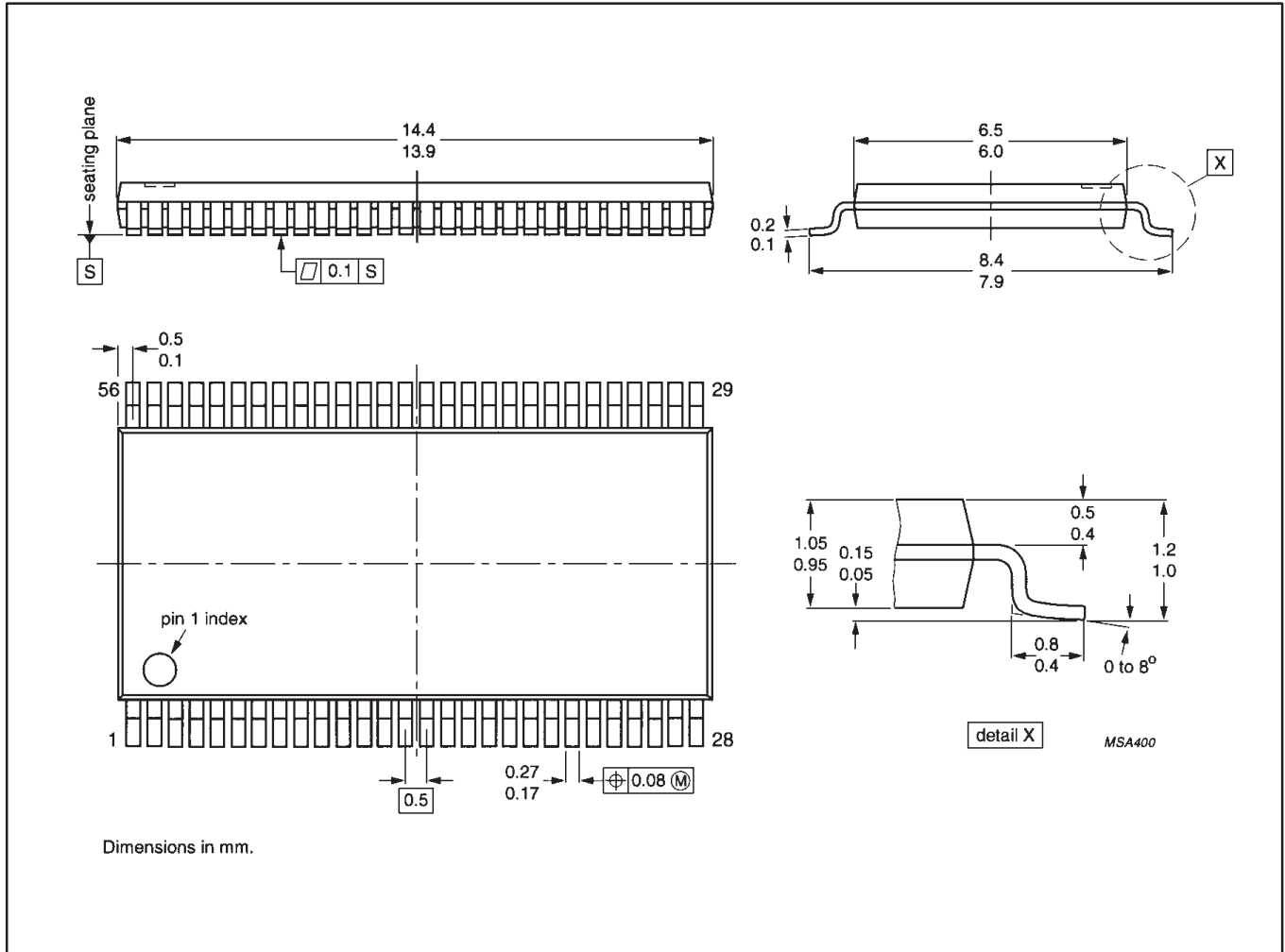

2.5V/3.3V 16-bit bus transceiver/register (3-State)

74ALVT16652

Data sheet status

Data sheet status	Product status	Definition [1]
Objective specification	Development	This data sheet contains the design target or goal specifications for product development. Specification may change in any manner without notice.
Preliminary specification	Qualification	This data sheet contains preliminary data, and supplementary data will be published at a later date. Philips Semiconductors reserves the right to make changes at any time without notice in order to improve design and supply the best possible product.
Product specification	Production	This data sheet contains final specifications. Philips Semiconductors reserves the right to make changes at any time without notice in order to improve design and supply the best possible product.

[1] Please consult the most recently issued datasheet before initiating or completing a design.

Definitions

Short-form specification — The data in a short-form specification is extracted from a full data sheet with the same type number and title. For detailed information see the relevant data sheet or data handbook.

Limiting values definition — Limiting values given are in accordance with the Absolute Maximum Rating System (IEC 134). Stress above one or more of the limiting values may cause permanent damage to the device. These are stress ratings only and operation of the device at these or at any other conditions above those given in the Characteristics sections of the specification is not implied. Exposure to limiting values for extended periods may affect device reliability.

Application information — Applications that are described herein for any of these products are for illustrative purposes only. Philips Semiconductors make no representation or warranty that such applications will be suitable for the specified use without further testing or modification.

Disclaimers

Life support — These products are not designed for use in life support appliances, devices or systems where malfunction of these products can reasonably be expected to result in personal injury. Philips Semiconductors customers using or selling these products for use in such applications do so at their own risk and agree to fully indemnify Philips Semiconductors for any damages resulting from such application.

Right to make changes — Philips Semiconductors reserves the right to make changes, without notice, in the products, including circuits, standard cells, and/or software, described or contained herein in order to improve design and/or performance. Philips Semiconductors assumes no responsibility or liability for the use of any of these products, conveys no license or title under any patent, copyright, or mask work right to these products, and makes no representations or warranties that these products are free from patent, copyright, or mask work right infringement, unless otherwise specified.

Philips Semiconductors
811 East Arques Avenue
P.O. Box 3409
Sunnyvale, California 94088-3409
Telephone 800-234-7381

© Copyright Philips Electronics North America Corporation 1998
All rights reserved. Printed in U.S.A.

print code

Date of release: 05-96

Document order number:

9397-750-03573

Let's make things better.



LittleDiode supplies new, hard to find or obsolete electronic components and semiconductors all over the world.

With over two million different components listed you are sure to find the part you need.

Feel free to visit us today at our online store:

LittleDiode.com

Looking forward to providing you with the best possible service.