

# 74HC1G125; 74HCT1G125

Bus buffer/line driver; 3-state

Rev. 05 — 23 December 2005

Product data sheet

## 1. General description

The 74HC1G125; 74HCT1G125 is a high-speed, Si-gate CMOS device.

The 74HC1G125; 74HCT1G125 provides one non-inverting buffer/line driver with 3-state output. The 3-state output is controlled by the output enable input (pin  $\overline{OE}$ ). A HIGH level at pin  $\overline{OE}$  causes the output to assume a high-impedance OFF-state.

The bus driver output currents are equal compared to the 74HC125 and 74HCT125.

## 2. Features

- Wide supply voltage range from 2.0 V to 6.0 V
- Symmetrical output impedance
- High noise immunity
- Low power consumption
- Balanced propagation delays
- ESD protection:
  - ◆ HBM EIA/JESD22-A114-C exceeds 2000 V
  - ◆ MM EIA/JESD22-A115-A exceeds 200 V
- Very small 5 pins packages
- Specified from  $-40\text{ }^{\circ}\text{C}$  to  $+85\text{ }^{\circ}\text{C}$  and  $-40\text{ }^{\circ}\text{C}$  to  $+125\text{ }^{\circ}\text{C}$

## 3. Quick reference data

**Table 1: Quick reference data**

$GND = 0\text{ V}$ ;  $T_{amb} = 25\text{ }^{\circ}\text{C}$ ;  $t_r = t_f \leq 6.0\text{ ns}$ .

Symbol	Parameter	Conditions	Min	Typ	Max	Unit
<b>74HC1G125</b>						
$t_{PHL}$ , $t_{PLH}$	propagation delay A to Y	$V_{CC} = 5\text{ V}$ ; $C_L = 15\text{ pF}$	-	9	-	ns
$C_i$	input capacitance		-	1.5	-	pF
$C_{PD}$	power dissipation capacitance	$V_I = GND$ to $V_{CC}$	<a href="#">[1]</a> -	30	-	pF

**PHILIPS**

**Table 1: Quick reference data ...continued** $GND = 0\text{ V}$ ;  $T_{amb} = 25\text{ °C}$ ;  $t_r = t_f \leq 6.0\text{ ns}$ .

Symbol	Parameter	Conditions	Min	Typ	Max	Unit
<b>74HCT1G125</b>						
$t_{PHL}$ , $t_{PLH}$	propagation delay A to Y	$V_{CC} = 5\text{ V}$ ; $C_L = 15\text{ pF}$	-	10	-	ns
$C_i$	input capacitance		-	1.5	-	pF
$C_{PD}$	power dissipation capacitance	$V_I = GND$ to $V_{CC} - 1.5\text{ V}$	[1]	27	-	pF

[1]  $C_{PD}$  is used to determine the dynamic power dissipation ( $P_D$  in  $\mu\text{W}$ ). $P_D = C_{PD} \times V_{CC}^2 \times f_i \times N + \Sigma(C_L \times V_{CC}^2 \times f_o)$  where: $f_i$  = input frequency in MHz; $f_o$  = output frequency in MHz; $C_L$  = output load capacitance in pF; $V_{CC}$  = supply voltage in V;

N = number of inputs switching;

 $\Sigma(C_L \times V_{CC}^2 \times f_o)$  = sum of the outputs.

## 4. Ordering information

**Table 2: Ordering information**

Type number	Package			Version
	Temperature range	Name	Description	
<b>74HC1G125</b>				
74HC1G125GW	-40 °C to +125 °C	TSSOP5	plastic thin shrink small outline package; 5 leads; body width 1.25 mm	SOT353-1
74HC1G125GV	-40 °C to +125 °C	SC-74A	plastic surface mounted package; 5 leads	SOT753
<b>74HCT1G125</b>				
74HCT1G125GW	-40 °C to +125 °C	TSSOP5	plastic thin shrink small outline package; 5 leads; body width 1.25 mm	SOT353-1
74HCT1G125GV	-40 °C to +125 °C	SC-74A	plastic surface mounted package; 5 leads	SOT753

## 5. Marking

**Table 3: Marking**

Type number	Marking code
74HC1G125GW	HM
74HC1G125GV	H25
74HCT1G125GW	TM
74HCT1G125GV	T25

## 6. Functional diagram

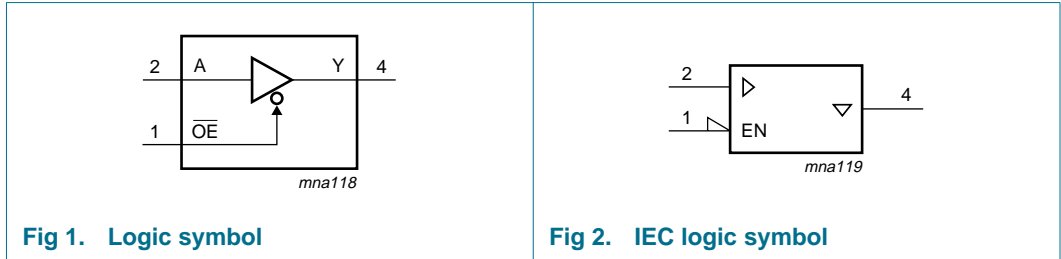

Fig 1. Logic symbol

Fig 2. IEC logic symbol

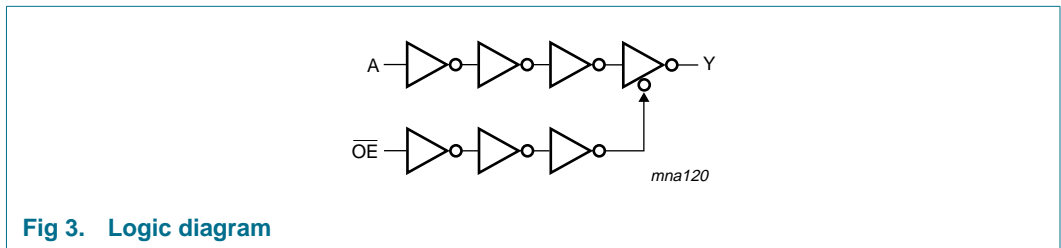

Fig 3. Logic diagram

## 7. Pinning information

### 7.1 Pinning

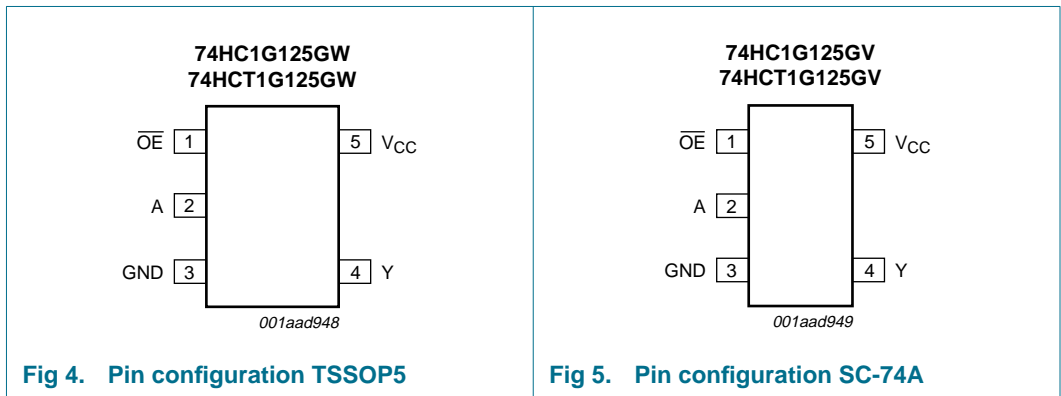

Fig 4. Pin configuration TSSOP5

Fig 5. Pin configuration SC-74A

### 7.2 Pin description

Table 4: Pin description

Symbol	Pin	Description
$\overline{OE}$	1	output enable input (active LOW)
A	2	data input
GND	3	ground (0 V)
Y	4	data output
$V_{CC}$	5	supply voltage

## 8. Functional description

### 8.1 Function table

Table 5: Function table <sup>[1]</sup>

Control	Input	Output
OE	A	Y
L	L	L
L	H	H
H	X	Z

- [1] H = HIGH voltage level;  
 L = LOW voltage level;  
 X = don't care;  
 Z = high-impedance OFF-state.

## 9. Limiting values

Table 6: Limiting values

In accordance with the Absolute Maximum Rating System (IEC 60134). Voltages are referenced to GND (ground = 0 V).

Symbol	Parameter	Conditions	Min	Max	Unit
$V_{CC}$	supply voltage		-0.5	+7.0	V
$I_{IK}$	input clamping current	$V_I < -0.5\text{ V}$ or $V_I > V_{CC} + 0.5\text{ V}$	<sup>[1]</sup> -	±20	mA
$I_{OK}$	output clamping current	$V_O < -0.5\text{ V}$ or $V_O > V_{CC} + 0.5\text{ V}$	<sup>[1]</sup> -	±20	mA
$I_O$	output current	$V_O = -0.5\text{ V}$ to $(V_{CC} + 0.5\text{ V})$	<sup>[1]</sup> -	±35	mA
$I_{CC}$	quiescent supply current		-	70	mA
$I_{GND}$	ground current		-	-70	mA
$T_{stg}$	storage temperature		-65	+150	°C
$P_{tot}$	total power dissipation	$T_{amb} = -40\text{ °C}$ to $+125\text{ °C}$	<sup>[2]</sup> -	200	mW

- [1] The input and output voltage ratings may be exceeded if the input and output current ratings are observed.  
 [2] Above 55 °C the value of  $P_{tot}$  derates linearly with 2.5 mW/K.

## 10. Recommended operating conditions

**Table 7: Recommended operating conditions**

Symbol	Parameter	Conditions	Min	Typ	Max	Unit
<b>74HC1G125</b>						
$V_{CC}$	supply voltage		2.0	5.0	6.0	V
$V_I$	input voltage		0	-	$V_{CC}$	V
$V_O$	output voltage		0	-	$V_{CC}$	V
$T_{amb}$	ambient temperature		-40	+25	+125	°C
$t_r, t_f$	input rise and fall times	$V_{CC} = 2.0\text{ V}$	-	-	1000	ns
		$V_{CC} = 4.5\text{ V}$	-	-	500	ns
		$V_{CC} = 6.0\text{ V}$	-	-	400	ns
<b>74HCT1G125</b>						
$V_{CC}$	supply voltage		4.5	5.0	5.5	V
$V_I$	input voltage		0	-	$V_{CC}$	V
$V_O$	output voltage		0	-	$V_{CC}$	V
$T_{amb}$	ambient temperature		-40	+25	+125	°C
$t_r, t_f$	input rise and fall times	$V_{CC} = 4.5\text{ V}$	-	-	500	ns

## 11. Static characteristics

**Table 8: Static characteristics 74HC1G125**

At recommended operating conditions; voltages are referenced to GND (ground = 0 V).

Symbol	Parameter	Conditions	Min	Typ	Max	Unit
<b><math>T_{amb} = -40\text{ °C to }+85\text{ °C}</math> [1]</b>						
$V_{IH}$	HIGH-state input voltage	$V_{CC} = 2.0\text{ V}$	1.5	1.2	-	V
		$V_{CC} = 4.5\text{ V}$	3.15	2.4	-	V
		$V_{CC} = 6.0\text{ V}$	4.2	3.2	-	V
$V_{IL}$	LOW-state input voltage	$V_{CC} = 2.0\text{ V}$	-	0.8	0.5	V
		$V_{CC} = 4.5\text{ V}$	-	2.1	1.35	V
		$V_{CC} = 6.0\text{ V}$	-	2.8	1.8	V
$V_{OH}$	HIGH-state output voltage	$V_I = V_{IH}$ or $V_{IL}$				
		$I_O = -20\text{ }\mu\text{A}; V_{CC} = 2.0\text{ V}$	1.9	2.0	-	V
		$I_O = -20\text{ }\mu\text{A}; V_{CC} = 4.5\text{ V}$	4.4	4.5	-	V
		$I_O = -20\text{ }\mu\text{A}; V_{CC} = 6.0\text{ V}$	5.9	6.0	-	V
		$I_O = -6.0\text{ mA}; V_{CC} = 4.5\text{ V}$	3.84	4.32	-	V
		$I_O = -7.8\text{ mA}; V_{CC} = 6.0\text{ V}$	5.34	5.81	-	V
$V_{OL}$	LOW-state output voltage	$V_I = V_{IH}$ or $V_{IL}$				
		$I_O = 20\text{ }\mu\text{A}; V_{CC} = 2.0\text{ V}$	-	0	0.1	V
		$I_O = 20\text{ }\mu\text{A}; V_{CC} = 4.5\text{ V}$	-	0	0.1	V
		$I_O = 20\text{ }\mu\text{A}; V_{CC} = 6.0\text{ V}$	-	0	0.1	V
		$I_O = 6.0\text{ mA}; V_{CC} = 4.5\text{ V}$	-	0.15	0.33	V
		$I_O = 7.8\text{ mA}; V_{CC} = 6.0\text{ V}$	-	0.16	0.33	V

**Table 8: Static characteristics 74HC1G125 ...continued**

At recommended operating conditions; voltages are referenced to GND (ground = 0 V).

Symbol	Parameter	Conditions	Min	Typ	Max	Unit
$I_{LI}$	input leakage current	$V_I = V_{CC}$ or GND; $V_{CC} = 6.0$ V	-	-	1.0	$\mu$ A
$I_{OZ}$	OFF-state output current	$V_I = V_{IH}$ or $V_{IL}$ ; $V_O = V_{CC}$ or GND; $V_{CC} = 6.0$ V	-	-	5	$\mu$ A
$I_{CC}$	quiescent supply current	$V_I = V_{CC}$ or GND; $I_O = 0$ A; $V_{CC} = 6.0$ V	-	-	10	$\mu$ A
$C_i$	input capacitance		-	1.5	-	pF
<b><math>T_{amb} = -40</math> °C to <math>+125</math> °C</b>						
$V_{IH}$	HIGH-state input voltage	$V_{CC} = 2.0$ V	1.5	-	-	V
		$V_{CC} = 4.5$ V	3.15	-	-	V
		$V_{CC} = 6.0$ V	4.2	-	-	V
$V_{IL}$	LOW-state input voltage	$V_{CC} = 2.0$ V	-	-	0.5	V
		$V_{CC} = 4.5$ V	-	-	1.35	V
		$V_{CC} = 6.0$ V	-	-	1.8	V
$V_{OH}$	HIGH-state output voltage	$V_I = V_{IH}$ or $V_{IL}$				
		$I_O = -20$ $\mu$ A; $V_{CC} = 2.0$ V	1.9	-	-	V
		$I_O = -20$ $\mu$ A; $V_{CC} = 4.5$ V	4.4	-	-	V
		$I_O = -20$ $\mu$ A; $V_{CC} = 6.0$ V	5.9	-	-	V
		$I_O = -6.0$ mA; $V_{CC} = 4.5$ V	3.7	-	-	V
$V_{OL}$	LOW-state output voltage	$V_I = V_{IH}$ or $V_{IL}$				
		$I_O = 20$ $\mu$ A; $V_{CC} = 2.0$ V	-	-	0.1	V
		$I_O = 20$ $\mu$ A; $V_{CC} = 4.5$ V	-	-	0.1	V
		$I_O = 20$ $\mu$ A; $V_{CC} = 6.0$ V	-	-	0.1	V
		$I_O = 6.0$ mA; $V_{CC} = 4.5$ V	-	-	0.4	V
		$I_O = 7.8$ mA; $V_{CC} = 6.0$ V	-	-	0.4	V
$I_{LI}$	input leakage current	$V_I = V_{CC}$ or GND; $V_{CC} = 6.0$ V	-	-	1.0	$\mu$ A
$I_{OZ}$	OFF-state output current	$V_I = V_{IH}$ or $V_{IL}$ ; $V_O = V_{CC}$ or GND; $V_{CC} = 6.0$ V	-	-	10	$\mu$ A
$I_{CC}$	quiescent supply current	$V_I = V_{CC}$ or GND; $I_O = 0$ A; $V_{CC} = 6.0$ V	-	-	20	$\mu$ A

[1] All typical values are measured at  $T_{amb} = 25$  °C.

**Table 9: Static characteristics 74HCT1G125**

At recommended operating conditions; voltages are referenced to GND (ground = 0 V).

Symbol	Parameter	Conditions	Min	Typ	Max	Unit
<b><math>T_{amb} = -40\text{ °C to }+85\text{ °C}</math> [1]</b>						
$V_{IH}$	HIGH-state input voltage	$V_{CC} = 4.5\text{ V to }5.5\text{ V}$	2.0	1.6	-	V
$V_{IL}$	LOW-state input voltage	$V_{CC} = 4.5\text{ V to }5.5\text{ V}$	-	1.2	0.8	V
$V_{OH}$	HIGH-state output voltage	$V_I = V_{IH}\text{ or }V_{IL}; V_{CC} = 4.5\text{ V}$				
		$I_O = -20\text{ }\mu\text{A}$	4.4	4.5	-	V
		$I_O = -6.0\text{ mA}$	3.84	4.32	-	V
$V_{OL}$	LOW-state output voltage	$V_I = V_{IH}\text{ or }V_{IL}; V_{CC} = 4.5\text{ V}$				
		$I_O = 20\text{ }\mu\text{A}$	-	0	0.1	V
		$I_O = 6.0\text{ mA}$	-	0.16	0.33	V
$I_{LI}$	input leakage current	$V_I = V_{CC}\text{ or GND}; V_{CC} = 5.5\text{ V}$	-	-	1.0	$\mu\text{A}$
$I_{OZ}$	OFF-state output current	$V_I = V_{IH}\text{ or }V_{IL}; V_O = V_{CC}\text{ or GND}; V_{CC} = 5.5\text{ V}$	-	-	5	$\mu\text{A}$
$I_{CC}$	quiescent supply current	$V_I = V_{CC}\text{ or GND}; I_O = 0\text{ A}; V_{CC} = 6.0\text{ V}$	-	-	10	$\mu\text{A}$
$\Delta I_{CC}$	additional quiescent supply current	$V_I = V_{CC} - 2.1\text{ V}; I_O = 0\text{ A}; V_{CC} = 4.5\text{ V to }5.5\text{ V}$	-	-	500	$\mu\text{A}$
$C_i$	input capacitance		-	1.5	-	pF
<b><math>T_{amb} = -40\text{ °C to }+125\text{ °C}</math></b>						
$V_{IH}$	HIGH-state input voltage	$V_{CC} = 4.5\text{ V to }5.5\text{ V}$	2.0	-	-	V
$V_{IL}$	LOW-state input voltage	$V_{CC} = 4.5\text{ V to }5.5\text{ V}$	-	-	0.8	V
$V_{OH}$	HIGH-state output voltage	$V_I = V_{IH}\text{ or }V_{IL}; V_{CC} = 4.5\text{ V}$				
		$I_O = -20\text{ }\mu\text{A}$	4.4	-	-	V
		$I_O = -6.0\text{ mA}$	3.7	-	-	V
$V_{OL}$	LOW-state output voltage	$V_I = V_{IH}\text{ or }V_{IL}; V_{CC} = 4.5\text{ V}$				
		$I_O = 20\text{ }\mu\text{A}$	-	-	0.1	V
		$I_O = 6.0\text{ mA}$	-	-	0.4	V
$I_{LI}$	input leakage current	$V_I = V_{CC}\text{ or GND}; V_{CC} = 5.5\text{ V}$	-	-	1.0	$\mu\text{A}$
$I_{OZ}$	OFF-state output current	$V_I = V_{IH}\text{ or }V_{IL}; V_O = V_{CC}\text{ or GND}; V_{CC} = 5.5\text{ V}$	-	-	10	$\mu\text{A}$
$I_{CC}$	quiescent supply current	$V_I = V_{CC}\text{ or GND}; I_O = 0\text{ A}; V_{CC} = 6.0\text{ V}$	-	-	20	$\mu\text{A}$
$\Delta I_{CC}$	additional quiescent supply current	$V_I = V_{CC} - 2.1\text{ V}; I_O = 0\text{ A}; V_{CC} = 4.5\text{ V to }5.5\text{ V}$	-	-	850	$\mu\text{A}$

[1] All typical values are measured at  $T_{amb} = 25\text{ °C}$ .

## 12. Dynamic characteristics

**Table 10: Dynamic characteristics 74HC1G125**

Voltages are referenced to GND (ground = 0 V);  $C_L = 50$  pF unless otherwise specified; for test circuit see [Figure 8](#)

Symbol	Parameter	Conditions	Min	Typ	Max	Unit
<b><math>T_{amb} = -40</math> °C to <math>+85</math> °C [1]</b>						
$t_{PHL}$ , $t_{PLH}$	propagation delay A to Y	see <a href="#">Figure 6</a>				
		$V_{CC} = 2.0$ V	-	24	125	ns
		$V_{CC} = 4.5$ V	-	10	25	ns
		$V_{CC} = 5$ V; $C_L = 15$ pF	-	9	-	ns
		$V_{CC} = 6.0$ V	-	8	21	ns
$t_{PZH}$ , $t_{PZL}$	3-state output enable time OE to Y	see <a href="#">Figure 7</a>				
		$V_{CC} = 2.0$ V	-	19	155	ns
		$V_{CC} = 4.5$ V	-	9	31	ns
		$V_{CC} = 6.0$ V	-	7	26	ns
$t_{PHZ}$ , $t_{PLZ}$	3-state output disable time OE to Y	see <a href="#">Figure 7</a>				
		$V_{CC} = 2.0$ V	-	18	155	ns
		$V_{CC} = 4.5$ V	-	12	31	ns
		$V_{CC} = 6.0$ V	-	11	26	ns
$C_{PD}$	power dissipation capacitance	$V_I = \text{GND to } V_{CC}$	[2]	-	30	- pF
<b><math>T_{amb} = -40</math> °C to <math>+125</math> °C</b>						
$t_{PHL}$ , $t_{PLH}$	propagation delay A to Y	see <a href="#">Figure 6</a>				
		$V_{CC} = 2.0$ V	-	-	150	ns
		$V_{CC} = 4.5$ V	-	-	30	ns
		$V_{CC} = 6.0$ V	-	-	26	ns
$t_{PZH}$ , $t_{PZL}$	3-state output enable time OE to Y	see <a href="#">Figure 7</a>				
		$V_{CC} = 2.0$ V	-	-	190	ns
		$V_{CC} = 4.5$ V	-	-	38	ns
		$V_{CC} = 6.0$ V	-	-	32	ns
$t_{PHZ}$ , $t_{PLZ}$	3-state output disable time OE to Y	see <a href="#">Figure 7</a>				
		$V_{CC} = 2.0$ V	-	-	190	ns
		$V_{CC} = 4.5$ V	-	-	38	ns
		$V_{CC} = 6.0$ V	-	-	32	ns

[1] All typical values are measured at  $T_{amb} = 25$  °C.

[2]  $C_{PD}$  is used to determine the dynamic power dissipation ( $P_D$  in  $\mu$ W).

$$P_D = C_{PD} \times V_{CC}^2 \times f_i \times N + \Sigma(C_L \times V_{CC}^2 \times f_o) \text{ where:}$$

$f_i$  = input frequency in MHz;

$f_o$  = output frequency in MHz;

$C_L$  = output load capacitance in pF;

$V_{CC}$  = supply voltage in V;

$N$  = number of inputs switching;

$\Sigma(C_L \times V_{CC}^2 \times f_o)$  = sum of the outputs.

**Table 11: Dynamic characteristics 74HCT1G125**

Voltages are referenced to GND (ground = 0 V);  $C_L = 50$  pF unless otherwise specified; for test circuit see [Figure 8](#)

Symbol	Parameter	Conditions	Min	Typ	Max	Unit
<b><math>T_{amb} = -40</math> °C to <math>+85</math> °C [1]</b>						
$t_{PHL}$ , $t_{PLH}$	propagation delay A to Y	see <a href="#">Figure 6</a>				
		$V_{CC} = 4.5$ V	-	11	30	ns
		$V_{CC} = 5$ V; $C_L = 15$ pF	-	10	-	ns
$t_{PZH}$ , $t_{PZL}$	3-state output enable time $\overline{OE}$ to Y	$V_{CC} = 4.5$ V; see <a href="#">Figure 7</a>	-	10	35	ns
$t_{PHZ}$ , $t_{PLZ}$	3-state output disable time $\overline{OE}$ to Y	$V_{CC} = 4.5$ V; see <a href="#">Figure 7</a>	-	11	31	ns
$C_{PD}$	power dissipation capacitance	$V_I = GND$ to $V_{CC} - 1.5$ V	[2]	-	27	pF
<b><math>T_{amb} = -40</math> °C to <math>+125</math> °C</b>						
$t_{PHL}$ , $t_{PLH}$	propagation delay A to Y	$V_{CC} = 4.5$ V; see <a href="#">Figure 6</a>	-	-	36	ns
$t_{PZH}$ , $t_{PZL}$	3-state output enable time $\overline{OE}$ to Y	$V_{CC} = 4.5$ V; see <a href="#">Figure 7</a>	-	-	42	ns
$t_{PHZ}$ , $t_{PLZ}$	3-state output disable time $\overline{OE}$ to Y	$V_{CC} = 4.5$ V; see <a href="#">Figure 7</a>	-	-	38	ns

[1] All typical values are measured at  $T_{amb} = 25$  °C.

[2]  $C_{PD}$  is used to determine the dynamic power dissipation ( $P_D$  in  $\mu$ W).

$$P_D = C_{PD} \times V_{CC}^2 \times f_i \times N + \Sigma(C_L \times V_{CC}^2 \times f_o) \text{ where:}$$

$f_i$  = input frequency in MHz;

$f_o$  = output frequency in MHz;

$C_L$  = output load capacitance in pF;

$V_{CC}$  = supply voltage in V;

$N$  = number of inputs switching;

$\Sigma(C_L \times V_{CC}^2 \times f_o)$  = sum of the outputs.

13. Waveforms

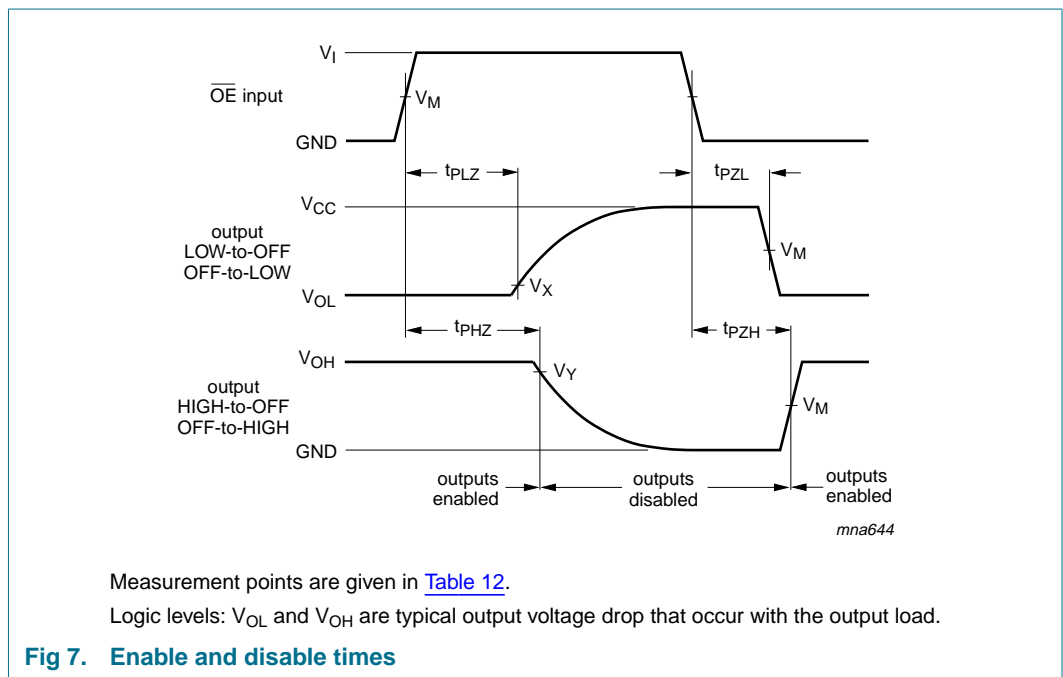
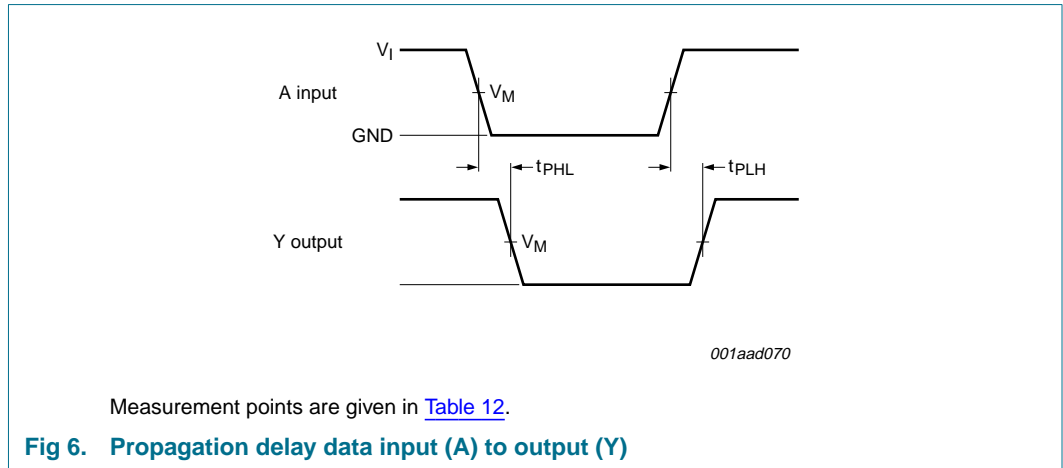

**Table 12: Measurement points**

Type	Input	Output		
	$V_M$	$V_M$	$V_X$	$V_Y$
74HC1G125	$0.5V_{CC}$	$0.5V_{CC}$	$V_{OL} + 0.3 V$	$V_{OH} - 0.3 V$
74HCT1G125	1.3 V	1.3 V	$V_{OL} + 0.3 V$	$V_{OH} - 0.3 V$

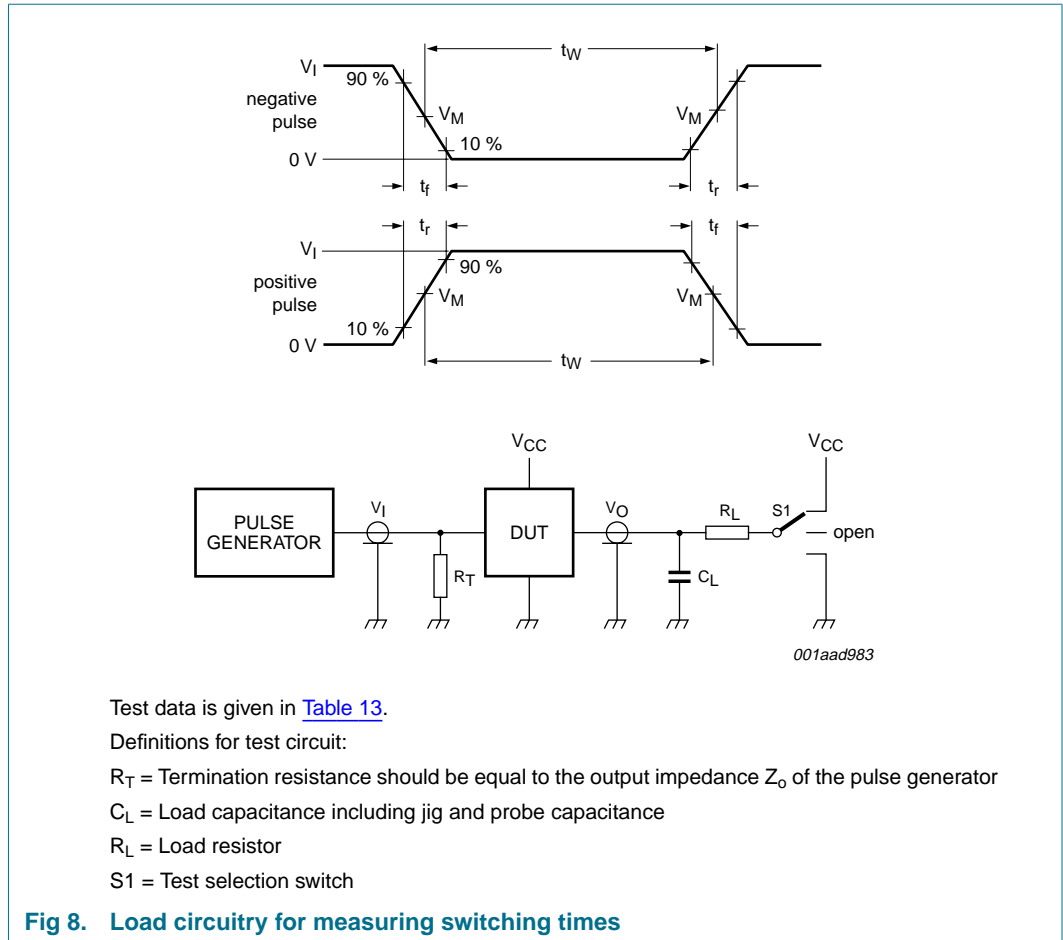

Table 13: Test data

Type	Input		Load		S1 position		
	$V_I$	$t_r, t_f$	$C_L$	$R_L$	$t_{PLH}, t_{PHL}$	$t_{PZH}, t_{PHZ}$	$t_{PZL}, t_{PLZ}$
74HC1G125	$V_{CC}$	6 ns	15 pF, 50 pF	1 k $\Omega$	open	GND	$V_{CC}$
74HCT1G125	3 V	6 ns	15 pF, 50 pF	1 k $\Omega$	open	GND	$V_{CC}$

14. Package outline

TSSOP5: plastic thin shrink small outline package; 5 leads; body width 1.25 mm

SOT353-1

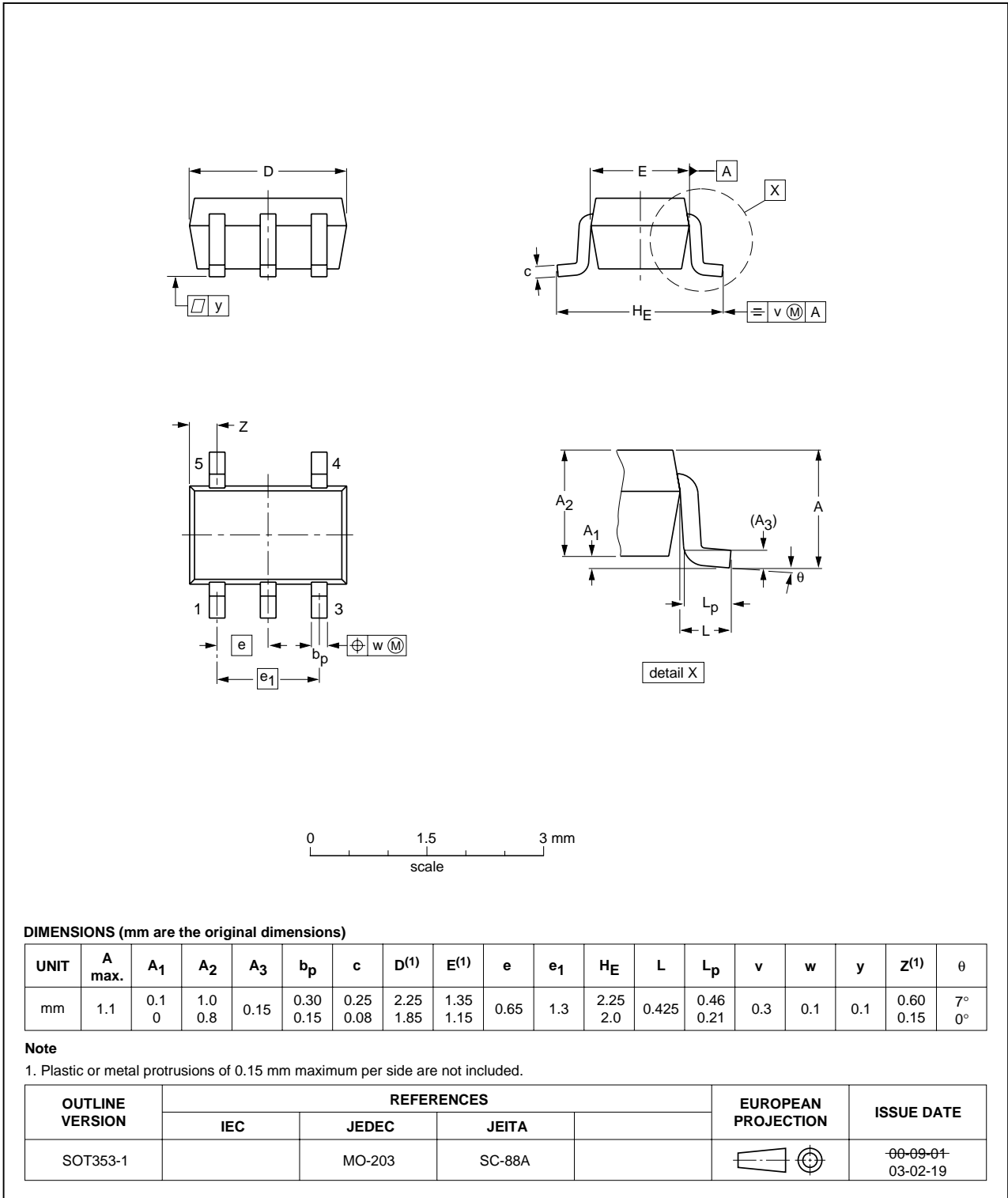

Fig 9. Package outline SOT353-1 (TSSOP5)

Plastic surface mounted package; 5 leads

SOT753

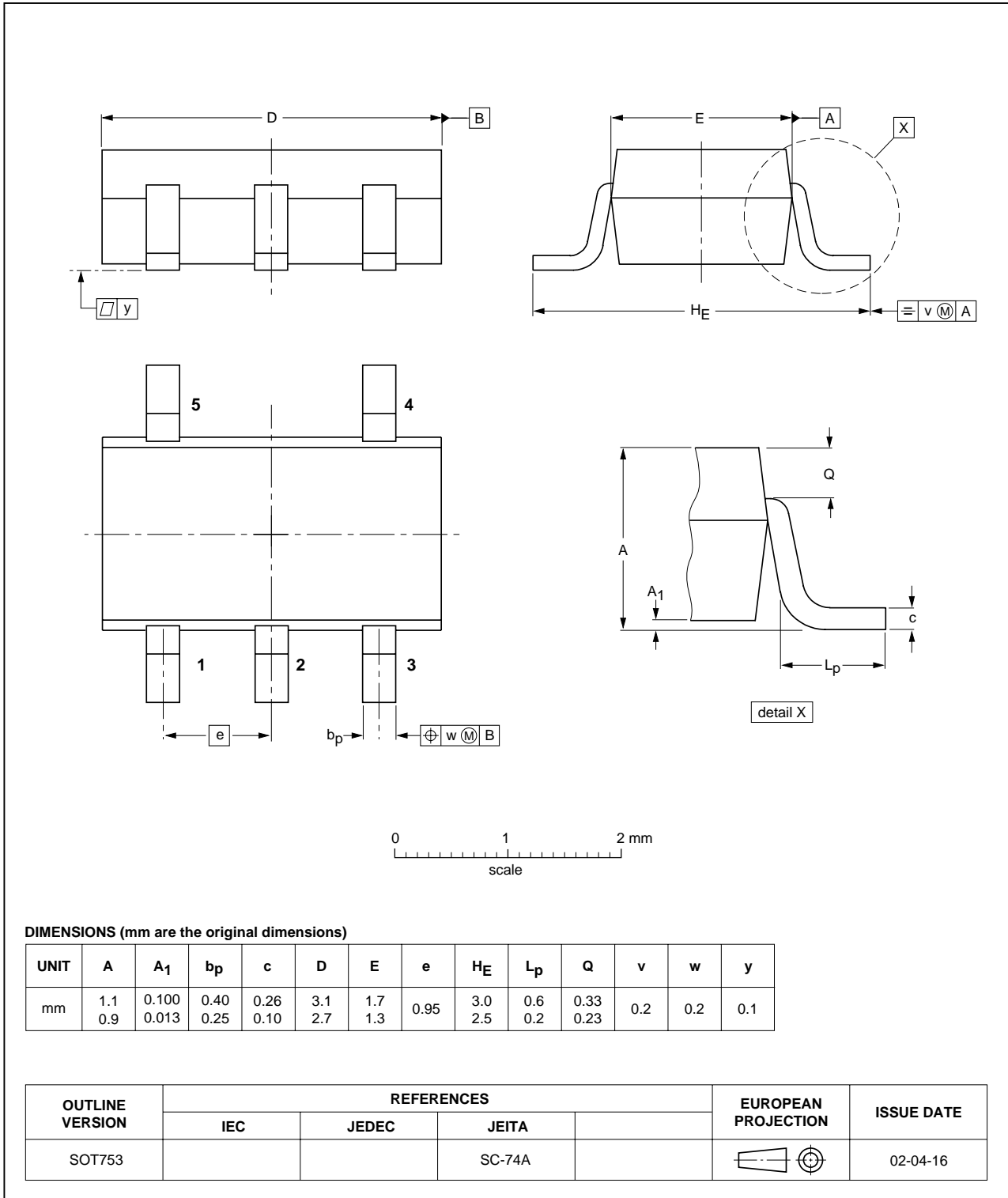

Fig 10. Package outline SOT753 (SC-74A)

## 15. Abbreviations

Table 14: Abbreviations

Acronym	Description
CMOS	Complementary Metal Oxide Semiconductor
ESD	ElectroStatic Discharge
HBM	Human Body Model
TTL	Transistor-Transistor Logic
MM	Machine Model

## 16. Revision history

Table 15: Revision history

Document ID	Release date	Data sheet status	Change notice	Doc. number	Supersedes
74HC_HCT1G125_5	20051223	Product data sheet	ECN05_085	-	74HC_HCT1G125_4
Modifications:					
<ul style="list-style-type: none"> <li>• The format of this data sheet has been redesigned to comply with the new presentation and information standard of Philips Semiconductors.</li> <li>• In <a href="#">Table 6 “Limiting values”</a> <ul style="list-style-type: none"> <li>– <math>I_O</math>: changed max value <math>\pm 12.5</math> into <math>\pm 35</math></li> <li>– <math>I_{CC}</math>: changed max value 25 into 70</li> <li>– <math>I_{GND}</math>: changed max value <math>-25</math> into <math>-70</math></li> </ul> </li> <li>• In <a href="#">Table 8 “Static characteristics 74HC1G125”</a>; <math>T_{amb} = -40\text{ }^{\circ}\text{C}</math> to <math>+85\text{ }^{\circ}\text{C}</math> <ul style="list-style-type: none"> <li>– <math>V_{OH}</math>: changed condition <math>I_O = -2.0\text{ mA}</math> into <math>I_O = -6.0\text{ mA}</math> and min value from 4.13 into 3.84</li> <li>– <math>V_{OH}</math>: changed condition <math>I_O = -2.6\text{ mA}</math> into <math>I_O = -7.8\text{ mA}</math> and min value from 5.63 into 5.34</li> <li>– <math>V_{OL}</math>: changed condition <math>I_O = 2.0\text{ mA}</math> into <math>I_O = 6.0\text{ mA}</math></li> <li>– <math>V_{OL}</math>: changed condition <math>I_O = 2.6\text{ mA}</math> into <math>I_O = 7.8\text{ mA}</math></li> </ul> </li> <li>• In <a href="#">Table 8 “Static characteristics 74HC1G125”</a>; <math>T_{amb} = -40\text{ }^{\circ}\text{C}</math> to <math>+125\text{ }^{\circ}\text{C}</math> <ul style="list-style-type: none"> <li>– <math>V_{OH}</math>: changed condition <math>I_O = -2.0\text{ mA}</math> into <math>I_O = -6.0\text{ mA}</math></li> <li>– <math>V_{OL}</math>: changed condition <math>I_O = 2.0\text{ mA}</math> into <math>I_O = 6.0\text{ mA}</math></li> </ul> </li> <li>• In <a href="#">Table 9 “Static characteristics 74HCT1G125”</a>; <math>T_{amb} = -40\text{ }^{\circ}\text{C}</math> to <math>+85\text{ }^{\circ}\text{C}</math> <ul style="list-style-type: none"> <li>– <math>V_{OH}</math>: changed condition <math>I_O = -2.0\text{ mA}</math> into <math>I_O = -6.0\text{ mA}</math> and min value from 4.13 into 3.84</li> <li>– <math>V_{OL}</math>: changed condition <math>I_O = 2.0\text{ mA}</math> into <math>I_O = 6.0\text{ mA}</math> and typ value from 0.15 into 0.16</li> </ul> </li> <li>• In <a href="#">Table 9 “Static characteristics 74HCT1G125”</a>; <math>T_{amb} = -40\text{ }^{\circ}\text{C}</math> to <math>+125\text{ }^{\circ}\text{C}</math> <ul style="list-style-type: none"> <li>– <math>V_{OH}</math>: changed condition <math>I_O = -2.0\text{ mA}</math> into <math>I_O = -6.0\text{ mA}</math></li> <li>– <math>V_{OL}</math>: changed condition <math>I_O = 2.0\text{ mA}</math> into <math>I_O = 6.0\text{ mA}</math></li> </ul> </li> </ul>					
74HC_HCT1G125_4	20040727	Product specification	-	9397 750 13725	74HC_HCT1G125_3
74HC_HCT1G125_3	20020517	Product specification	-	9397 750 09718	74HC_HCT1G125_2
74HC_HCT1G125_2	20010302	Product specification	-	9397 750 07966	74HC_HCT1G125_1
74HC_HCT1G125_1	19981110	Product specification	-	9397 750 03693	-

## 17. Data sheet status

Level	Data sheet status <sup>[1]</sup>	Product status <sup>[2] [3]</sup>	Definition
I	Objective data	Development	This data sheet contains data from the objective specification for product development. Philips Semiconductors reserves the right to change the specification in any manner without notice.
II	Preliminary data	Qualification	This data sheet contains data from the preliminary specification. Supplementary data will be published at a later date. Philips Semiconductors reserves the right to change the specification without notice, in order to improve the design and supply the best possible product.
III	Product data	Production	This data sheet contains data from the product specification. Philips Semiconductors reserves the right to make changes at any time in order to improve the design, manufacturing and supply. Relevant changes will be communicated via a Customer Product/Process Change Notification (CPCN).

[1] Please consult the most recently issued data sheet before initiating or completing a design.

[2] The product status of the device(s) described in this data sheet may have changed since this data sheet was published. The latest information is available on the Internet at URL <http://www.semiconductors.philips.com>.

[3] For data sheets describing multiple type numbers, the highest-level product status determines the data sheet status.

## 18. Definitions

**Short-form specification** — The data in a short-form specification is extracted from a full data sheet with the same type number and title. For detailed information see the relevant data sheet or data handbook.

**Limiting values definition** — Limiting values given are in accordance with the Absolute Maximum Rating System (IEC 60134). Stress above one or more of the limiting values may cause permanent damage to the device. These are stress ratings only and operation of the device at these or at any other conditions above those given in the Characteristics sections of the specification is not implied. Exposure to limiting values for extended periods may affect device reliability.

**Application information** — Applications that are described herein for any of these products are for illustrative purposes only. Philips Semiconductors makes no representation or warranty that such applications will be suitable for the specified use without further testing or modification.

## 19. Disclaimers

**Life support** — These products are not designed for use in life support appliances, devices, or systems where malfunction of these products can reasonably be expected to result in personal injury. Philips Semiconductors

## 21. Contact information

For additional information, please visit: <http://www.semiconductors.philips.com>

For sales office addresses, send an email to: [sales.addresses@www.semiconductors.philips.com](mailto:sales.addresses@www.semiconductors.philips.com)

customers using or selling these products for use in such applications do so at their own risk and agree to fully indemnify Philips Semiconductors for any damages resulting from such application.

**Right to make changes** — Philips Semiconductors reserves the right to make changes in the products - including circuits, standard cells, and/or software - described or contained herein in order to improve design and/or performance. When the product is in full production (status 'Production'), relevant changes will be communicated via a Customer Product/Process Change Notification (CPCN). Philips Semiconductors assumes no responsibility or liability for the use of any of these products, conveys no license or title under any patent, copyright, or mask work right to these products, and makes no representations or warranties that these products are free from patent, copyright, or mask work right infringement, unless otherwise specified.

## 20. Trademarks

**Notice** — All referenced brands, product names, service names and trademarks are the property of their respective owners.

## 22. Contents

1	General description . . . . .	1
2	Features . . . . .	1
3	Quick reference data . . . . .	1
4	Ordering information . . . . .	2
5	Marking . . . . .	2
6	Functional diagram . . . . .	3
7	Pinning information . . . . .	3
7.1	Pinning . . . . .	3
7.2	Pin description . . . . .	3
8	Functional description . . . . .	4
8.1	Function table . . . . .	4
9	Limiting values . . . . .	4
10	Recommended operating conditions . . . . .	5
11	Static characteristics . . . . .	5
12	Dynamic characteristics . . . . .	8
13	Waveforms . . . . .	10
14	Package outline . . . . .	12
15	Abbreviations . . . . .	14
16	Revision history . . . . .	14
17	Data sheet status . . . . .	15
18	Definitions . . . . .	15
19	Disclaimers . . . . .	15
20	Trademarks . . . . .	15
21	Contact information . . . . .	15



© Koninklijke Philips Electronics N.V. 2005

All rights are reserved. Reproduction in whole or in part is prohibited without the prior written consent of the copyright owner. The information presented in this document does not form part of any quotation or contract, is believed to be accurate and reliable and may be changed without notice. No liability will be accepted by the publisher for any consequence of its use. Publication thereof does not convey nor imply any license under patent- or other industrial or intellectual property rights.

Date of release: 23 December 2005  
Document number: 74HC\_HCT1G125\_5

Published in The Netherlands



LittleDiode supplies new, hard to find or obsolete electronic components and semiconductors all over the world.

With over two million different components listed you are sure to find the part you need.

Feel free to visit us today at our online store:

[LittleDiode.com](http://LittleDiode.com)

Looking forward to providing you with the best possible service.