

ARF442 200W 100V 13.56MHz
ARF443 200W 100V 13.56MHz

THE ARF442 PIN-OUTS ARE MIRROR IMAGE OF THE ARF443.

RF OPERATION (1-15MHz)

POWER MOS IV®

N-CHANNEL ENHANCEMENT MODE RF POWER MOSFET

The ARF442 and ARF443 comprise a symmetric pair of RF power transistors designed for narrow-band push-pull commercial, medical and industrial RF power amplifier applications.

- Specified 100 Volt, 13.56 MHz Characteristics:
- Output Power = 200 Watts.
- Gain = 22dB (Typ.)
- Efficiency = 73% (Typ.)
- Low Cost Common Source RF Package.
- Very High Breakdown for Improved Ruggedness.
- Low Thermal Resistance.
- Nitride Passivated Die for Improved Reliability.

MAXIMUM RATINGS

All Ratings: $T_C = 25^\circ\text{C}$ unless otherwise specified.

Symbol	Parameter	ARF442/443	UNIT
V_{DSS}	Drain-Source Voltage	300	Volts
V_{DGO}	Drain-Gate Voltage	300	
I_D	Continuous Drain Current @ $T_C = 25^\circ\text{C}$	8	Amps
V_{GS}	Gate-Source Voltage	± 30	Volts
P_D	Total Power Dissipation @ $T_C = 25^\circ\text{C}$	167	Watts
$R_{\theta JC}$	Junction to Case	0.75	$^\circ\text{C/W}$
T_J, T_{STG}	Operating and Storage Junction Temperature Range	-55 to 150	$^\circ\text{C}$
T_L	Lead Temperature: 0.063" from Case for 10 Sec.	300	

STATIC ELECTRICAL CHARACTERISTICS

Symbol	Characteristic / Test Conditions	MIN	TYP	MAX	UNIT
BV_{DSS}	Drain-Source Breakdown Voltage ($V_{GS} = 0V, I_D = 250 \mu\text{A}$)	300			Volts
$V_{DS(ON)}$	On State Drain Voltage ^① ($I_D(ON) = 6.5A, V_{GS} = 10V$)			6	
I_{DSS}	Zero Gate Voltage Drain Current ($V_{DS} = V_{DSS}, V_{GS} = 0V$)			250	μA
	Zero Gate Voltage Drain Current ($V_{DS} = 0.8 V_{DSS}, V_{GS} = 0V, T_C = 125^\circ\text{C}$)			1000	
I_{GSS}	Gate-Source Leakage Current ($V_{GS} = \pm 30V, V_{DS} = 0V$)			± 100	nA
g_{fs}	Forward Transconductance ($V_{DS} = 10V, I_D = 5.5A$)	3.5	4.5		mhos
$V_{GS(TH)}$	Gate Threshold Voltage ($V_{DS} = V_{GS}, I_D = 50mA$)	2		5	Volts

 **CAUTION:** These Devices are Sensitive to Electrostatic Discharge. Proper Handling Procedures Should Be Followed.

APT Website - <http://www.advancedpower.com>

USA
 405 S.W. Columbia Street
EUROPE

Avenue J.F. Kennedy Bât B4 Parc Cadéra Nord

Bend, Oregon 97702-1035

F-33700 Merignac - France

Phone: (541) 382-8028

Phone: (33) 5 57 92 15 15

FAX: (541) 388-0364

FAX: (33) 5 56 47 97 61

Symbol	Characteristic	Test Conditions	MIN	TYP	MAX	UNIT
C_{iss}	Input Capacitance	$V_{GS} = 0V$ $V_{DS} = 100V$ $f = 1\text{ MHz}$		730	900	pF
C_{oss}	Output Capacitance			100	140	
C_{rss}	Reverse Transfer Capacitance			33	50	

FUNCTIONAL CHARACTERISTICS

Symbol	Characteristic	Test Conditions	MIN	TYP	MAX	UNIT
G_{PS1}	Common Source Amplifier Power Gain	$V_{DD} = 100V$ $V_{GS} = 0V$ $P_{out} = 200W$ $f = 13.56\text{MHz}$	17	18.9		dB
η_1	Drain Efficiency			73		%
Ψ	Electrical Ruggedness VSWR 30:1		No Degradation in Output Power			
G_{PS2}	Common Source Amplifier Power Gain	$V_{DD} = 100V, P_{out} = 200W$		22		dB
η_2	Drain Efficiency	$I_{DQ} = 50\text{mA}, f = 13.56\text{MHz}$		65		%

① Pulse Test: Pulse width < 380 μs , Duty Cycle < 2%

APT Reserves the right to change, without notice, the specifications and information contained herein.

TYPICAL 13.56 MHz, 400 WATT PUSH-PULL CLASS 'C' POWER AMPLIFIER CIRCUIT

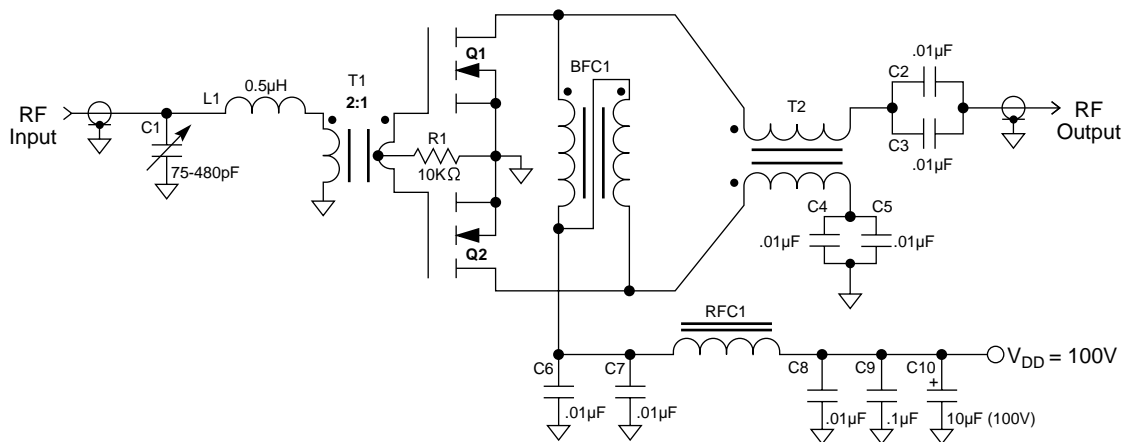

Parts List

- C1 = 75-480pF Compression Mica
- C2, C3, C4, C5, C6, C7 & C8 = .01 μF @ 200V, CK06
- C9 = .1 μF @ 100V, CK06
- C10 = 10 μF @ 100V Electrolytic
- R1 = 10K Ω , 5%, 1/4W, Carbon
- Q1 = ARF442
- Q2 = ARF443

L1 = 7.5 T of #18AWG, ID = .438", L = 0.5 μH

BFC1 = Balanced DC Feed Choke; 7 T of #22 stranded PTFE twisted pair on an Indiana General #F624-19-Q1 toroid. $\mu_i = 125$
 RFC1 = 2 T of #18 stranded PTFE on a Fair-Rite #2677006301 shield bead. $\mu_i = 2000$

T1 = 4:1 Z Conventional Transformer; 2:1 T of #22 stranded PTFE on a Fair-Rite #2843000202 Balun Core. $\mu_i = 850$

T2 = 1:1 Z Transmission Line Transformer, using 50 Ω coax.

- Coax = 22" of mini 50 Ω PTFE coax, OD = .095"
- A large 2-hole balun core was constructed by gluing two Fair-Rite #2643102002, $\mu_i = 850$ cores together.
- The transformer is constructed by winding 4.5 turns of the coax around the center of the balun core.

PCB = .062" G10 Epoxy Glass.

ARF442/443

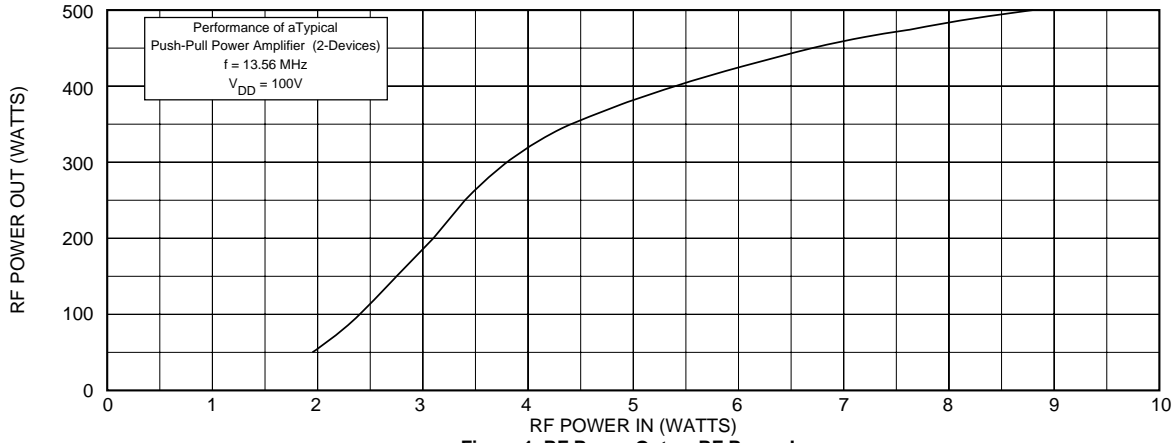

Figure 1, RF Power Out vs RF Power In

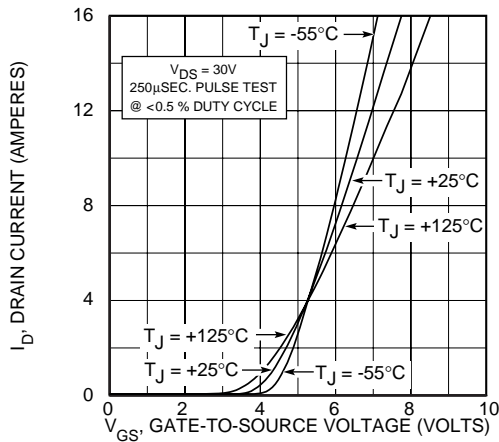

Figure 2, Typical Transfer Characteristics

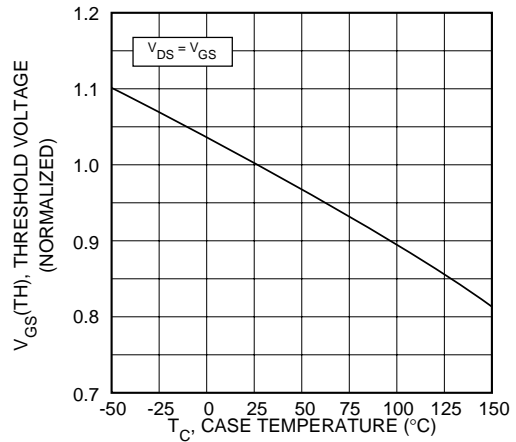

Figure 3, Threshold Voltage vs Temperature

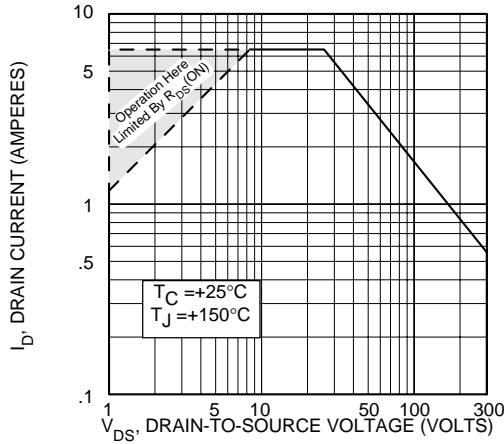

Figure 4, Maximum DC Safe Operating Area

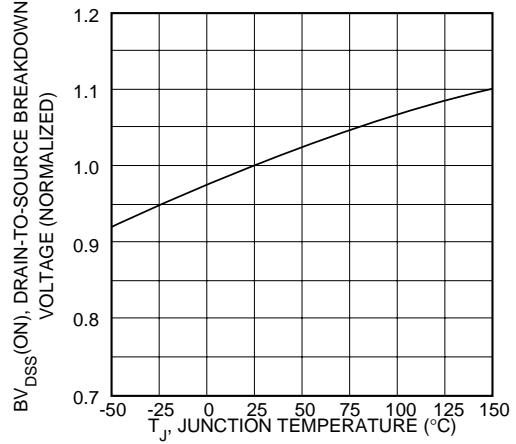

Figure 5, Breakdown Voltage vs Temperature

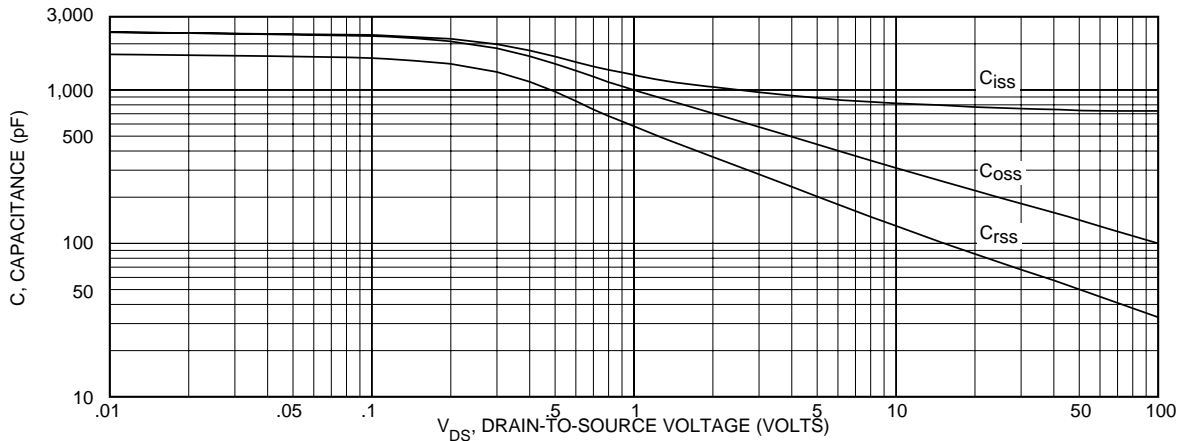
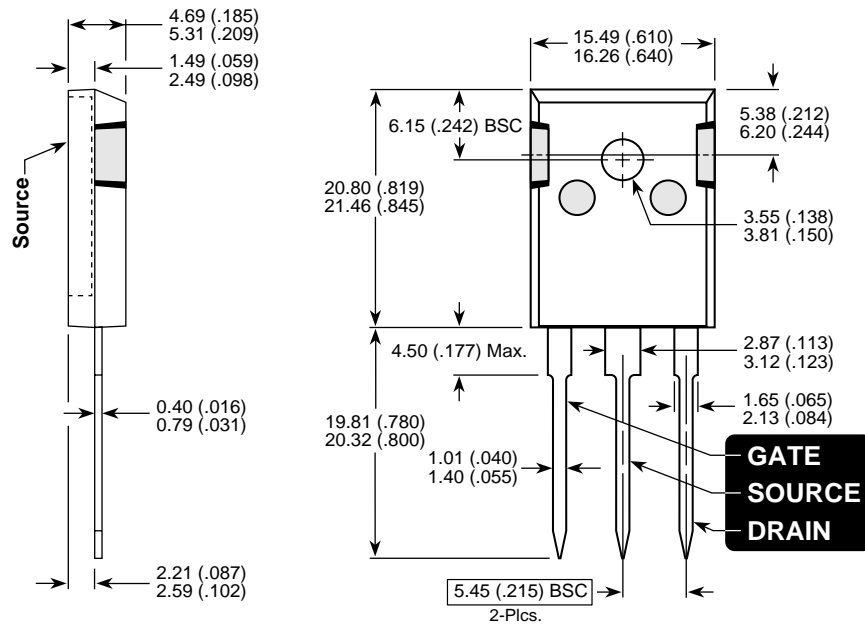

Figure 6, Typical Capacitance vs. Drain-to-Source Voltage

TO-247AD Package Outline

ARF442



Dimensions in Millimeters and (Inches)

ARF443

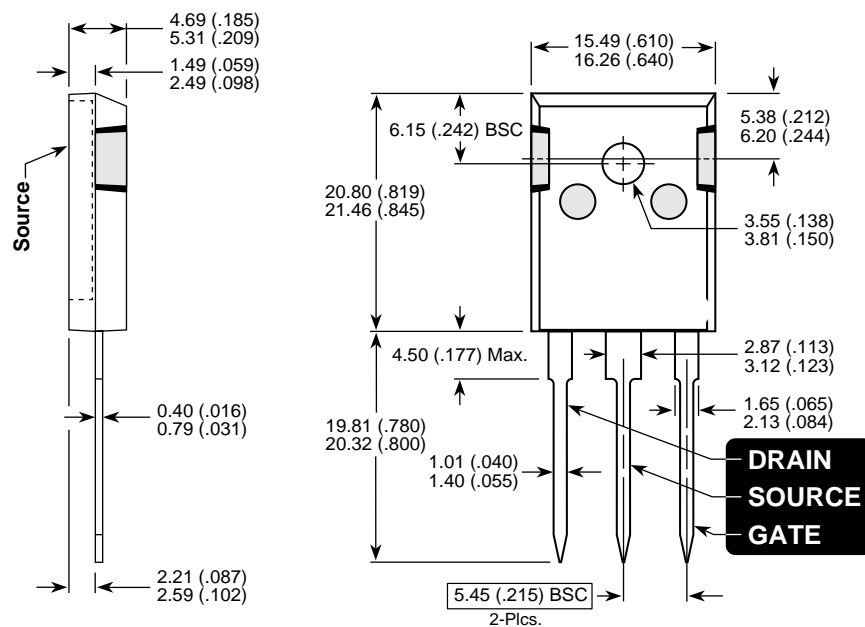

Dimensions in Millimeters and (Inches)

NOTE: The ARF442 and ARF443 comprise a symmetric pair of RF power transistors and meet the same electrical specifications. The device pin-outs are the mirror image of each other to allow ease of use as a push-pull pair.



CAUTION: These Devices are Sensitive to Electrostatic Discharge. Proper Handling Procedures Should Be Followed.

USA
405 S.W. Columbia Street
EUROPE

Avenue J.F. Kennedy Bât B4 Parc Cadéra Nord F-33700 Merignac - France

Bend, Oregon 97702-1035 Phone: (541) 382-8028 FAX: (541) 388-0364

Phone: (33) 5 57 92 15 15 FAX: (33) 5 56 47 97 61

This datasheet has been downloaded from:

www.DatasheetCatalog.com

Datasheets for electronic components.



LittleDiode supplies new, hard to find or obsolete electronic components and semiconductors all over the world.

With over two million different components listed you are sure to find the part you need.

Feel free to visit us today at our online store:

LittleDiode.com

Looking forward to providing you with the best possible service.