

FEATURES

- Low Offset Voltage: 50 μV max
- Low Offset Voltage Drift: 0.5 $\mu\text{V}/^\circ\text{C}$ max
- Very Low Bias Current
- 25°C: 100 pA max
- 55°C to +125°C: 450 pA max
- Very High Open-Loop Gain: 2000 V/mV min
- Low Supply Current (per Amplifier): 625 μA max
- Operates from ± 2 V to ± 20 V Supplies
- High Common-Mode Rejection: 120 dB min

APPLICATIONS

- Strain Gage and Bridge Amplifiers
- High Stability Thermocouple Amplifiers
- Instrumentation Amplifiers
- Photo-Current Monitors
- High Gain Linearity Amplifiers
- Long-Term Integrators/Filters
- Sample-and-Hold Amplifiers
- Peak Detectors
- Logarithmic Amplifiers
- Battery-Powered Systems

GENERAL DESCRIPTION

The OP497 is a quad op amp with precision performance in the space-saving, industry standard 16-lead SOIC package. Its combination of exceptional precision with low power and extremely low input bias current makes the quad OP497 useful in a wide variety of applications.

Precision performance of the OP497 includes very low offset, under 50 μV , and low drift, below 0.5 $\mu\text{V}/^\circ\text{C}$. Open-loop gain exceeds 2000 V/mV ensuring high linearity in every application. Errors due to common-mode signals are eliminated by the OP497's common-mode rejection of over 120 dB. The OP497's power supply rejection of over 120 dB minimizes offset voltage changes experienced in battery-powered systems. Supply current of the OP497 is under 625 μA per amplifier, and it can operate with supply voltages as low as ± 2 V.

The OP497 utilizes a superbeta input stage with bias current cancellation to maintain picoamp bias currents at all temperatures. This is in contrast to FET input op amps whose bias currents start in the picoamp range at 25°C, but double for every 10°C rise in temperature, to reach the nanoamp range above 85°C. Input bias current of the OP497 is under 100 pA at 25°C and is under 450 pA over the military temperature range.

Combining precision, low power, and low bias current, the OP497 is ideal for a number of applications, including instrumentation amplifiers, log amplifiers, photo-diode preamplifiers, and long-term integrators. For a single device, see the OP97; for a dual device, see the OP297.

REV. D

Information furnished by Analog Devices is believed to be accurate and reliable. However, no responsibility is assumed by Analog Devices for its use, nor for any infringements of patents or other rights of third parties that may result from its use. No license is granted by implication or otherwise under any patent or patent rights of Analog Devices.

PIN CONNECTIONS

16-Lead Wide Body SOIC (S-Suffix)

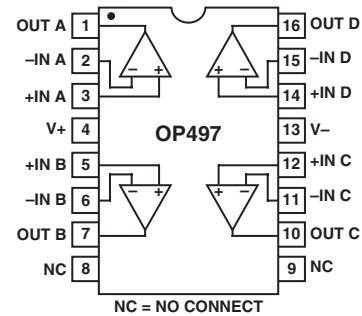

14-Lead Plastic Dip (P-Suffix)

14-Lead Ceramic Dip (Y-Suffix)

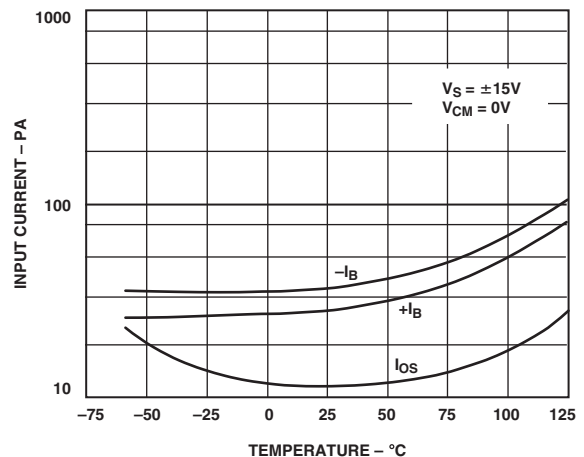
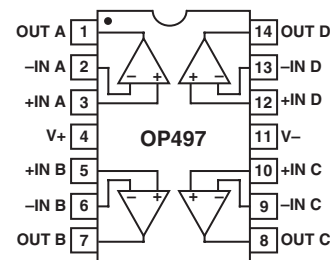

Input Bias, Offset Current vs. Temperature

OP497—SPECIFICATIONS (@ $V_S = 15\text{ V}$, $T_A = 25^\circ\text{C}$, unless otherwise noted.)

Parameter	Symbol	Condition	A			F			C/G			Unit
			Min	Typ	Max	Min	Typ	Max	Min	Typ	Max	
INPUT CHARACTERISTICS												
Offset Voltage	V_{OS}	$-40^\circ\text{C} \leq +85^\circ\text{C}$ $-55^\circ\text{C} \leq +125^\circ\text{C}$	20	50		40	75		80	150	μV	
Average Input Offset Voltage Drift	TCV_{OS}	$T_{MIN} - T_{MAX}$	0.2	0.5		0.4	1.0		0.6	1.5	$\mu\text{V}/^\circ\text{C}$	
Long-Term Input Offset Voltage Stability			0.1			0.1			0.1		$\mu\text{V}/\text{Mo}$	
Input Bias Current	I_B	$V_{CM} = 0\text{ V}$ $-40^\circ \leq T_A \leq +85^\circ\text{C}$ $-55^\circ \leq T_A \leq +125^\circ\text{C}$	30	100		40	150		60	200	pA	
Average Input Bias Current Drift	TC_{IB}	$-40^\circ \leq T_A \leq +85^\circ\text{C}$ $-55^\circ \leq T_A \leq +125^\circ\text{C}$				0.3			0.3		$\text{pA}/^\circ\text{C}$	
Input Offset Current	I_{OS}	$V_{CM} = 0\text{ V}$ $-40^\circ \leq T_A \leq +85^\circ\text{C}$ $-55^\circ \leq T_A \leq +125^\circ\text{C}$	15	100		30	150		50	200	pA	
Average Input Offset Current Drift	TC_{IOS}		0.2			0.3			0.4		$\text{pA}/^\circ\text{C}$	
Input Voltage Range ¹	IVR		+13	+14		+13	t14		+13	+14	V	
Common-Mode Rejection	CMR	$T_{MIN} - T_{MAX}$ $V_{CM} = \pm 13\text{ V}$	+13	+13.5		+13	+13.5		+13	+13.5	dB	
Large Signal Voltage Gain	A_{VO}	$T_{MIN} - T_{MAX}$ $V_O = \pm 10\text{ V}$, $R_L = 2\text{ k}\Omega$ $-40^\circ \leq T_A \leq +85^\circ\text{C}$ $-55^\circ \leq T_A \leq +125^\circ\text{C}$	114	130		108	120		108	120		
Input Resistance Differential Mode	R_{IN}		2000	6000		1500	4000		1200	4000	V/mV	
Input Resistance Common Mode	R_{INCM}		1200	4000		800	2000		800	2000		
Input Capacitance	C_{IN}		1000	3000		1000	3000		800	3000		
			30			30			30		$\text{M}\Omega$	
			500			500			500		$\text{G}\Omega$	
			3			3			3		pF	
OUTPUT CHARACTERISTICS												
Output Voltage Swing	V_O	$R_L = 2\text{ k}\Omega$ $R_L = 10\text{ k}\Omega$ $T_{MIN} - T_{MAX}$ $R_L = 10\text{ k}\Omega$	± 13	± 13.7		± 13	± 13.7		± 13	$\pm 13.7\text{V}$		
Short Circuit	I_{SC}		± 13	± 14		± 13	± 14		± 13	± 14		
			± 13	± 13.5		± 13	± 13.5		± 13	± 13.5		
				± 25			± 25			± 25	mA	
POWER SUPPLY												
Power Supply Rejection Ratio	PSRR	$V_S = \pm 2\text{ V to } \pm 20\text{ V}$ $V_S = \pm 2.5\text{ V to } \pm 20\text{ V}$ $T_{MIN} - T_{MAX}$	120	140		114	135		114	135	dB	
Supply Current (per Amplifier)	I_{SY}	No Load $T_{MIN} - T_{MAX}$	114	130		108	120		108	120	μA	
Supply Voltage Range	V_S	Operating Range $T_{MIN} - T_{MAX}$	± 2	± 20		± 2	± 20		± 2	± 20	V	
			± 2.5	± 20		± 2.5	± 20		± 2.5	± 20		
DYNAMIC PERFORMANCE												
Slew Rate	SR		0.05	0.15		0.05	0.15		0.05	0.15	$\text{V}/\mu\text{S}$	
Gain Bandwidth Product	GBW			500			500			500	kHz	
Channel Separation	CS	$V_O = 20\text{ V}_{p-p}$, $f_o = 10\text{ Hz}$		150			150			150	dB	
NOISE PERFORMANCE												
Voltage Noise	$e_{n\text{ p-p}}$	0.1 Hz to 10 Hz		0.3			0.3			0.3	$\mu\text{V}/\text{p-p}$	
Voltage Noise Density	$e_n = 10\text{ Hz}$ $e_n = 1\text{ kHz}$			17			17			17	$\text{nV}/\sqrt{\text{Hz}}$	
Current Noise Density	$i_n = 10\text{ Hz}$			15			15			15	$\text{nV}/\sqrt{\text{Hz}}$	
				20			20			20	$\text{fA}/\sqrt{\text{Hz}}$	

NOTE

¹Guaranteed by CMR Test.

Specifications subject to change without notice.

ABSOLUTE MAXIMUM RATINGS¹

Supply Voltage	±20 V
Input Voltage ²	20 V
Differential Input Voltage ²	40 V
Output Short-Circuit Duration	Indefinite
Storage Temperature Range	
Y Package	-65°C to +175°C
P, S Package	-65°C to +150°C
Operating Temperature Range	
OP497A, C (Y)	-55°C to +125°C
OP497F, G (Y)	-40°C to +85°C
OP497F, G (P, S)	-40°C to +85°C
Junction Temperature	
Y Package	-65°C to +175°C
P, S Package	-65°C to +150°C
Lead Temperature Range (Soldering 60 sec)	300°C

Package Type	θ_{JA} ³	θ_{JC}	Unit
14-Pin Cerdip (Y)	94	10	°C/W
14-Pin Plastic DIP (P)	76	33	°C/W
16-Pin SOIC (S)	92	23	°C/W

NOTES

¹Absolute Maximum Ratings apply to both DICE and packaged parts, unless otherwise noted.

²For supply voltages less than ±20 V, the absolute maximum input voltage is equal to the supply voltage.

³HIA is specified for worst-case mounting conditions, i.e., θ_{JA} is specified for device in socket for cerdip, P-DIP packages; θ_{JA} is specified for device soldered to printed circuit board for SOIC package.

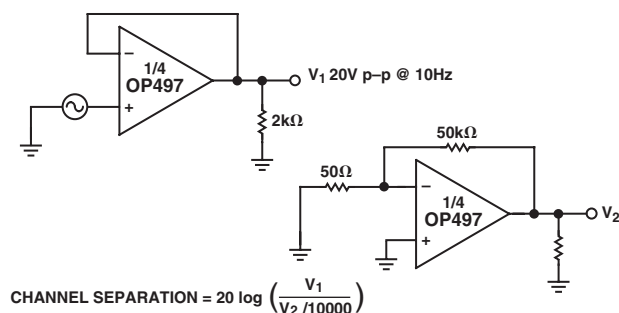

Channel Separation Test Circuit

ORDERING GUIDE

Model	Temperature Range	Package Description	Package Option
OP497AY*	-55°C to +125°C	14-Lead Cerdip	Q-14
OP497CY*	-55°C to +125°C	14-Lead Cerdip	Q-14
OP497FP	-40°C to +85°C	14-Lead Plastic DIP	N-14
OP497FS	-40°C to +85°C	16-Lead SOIC	R-16
OP497GP	-40°C to +85°C	14-Lead Plastic DIP	N-14
OP497GS	-40°C to +85°C	16-Lead SOIC	R-16

*Not for new design; obsolete April 2002.

For a military processed devices, please refer to the Standard Microcircuit Drawing (SMD) available at www.dscc.dla.mil/programs.milspec./default.asp.

SMD Part Number	ADI Part Number
5962-9452101M2A*	OP497BRC
5962-9452101MCA	OP497BY

*Not for new designs; obsolete April 2002.

DICE CHARACTERISTICS

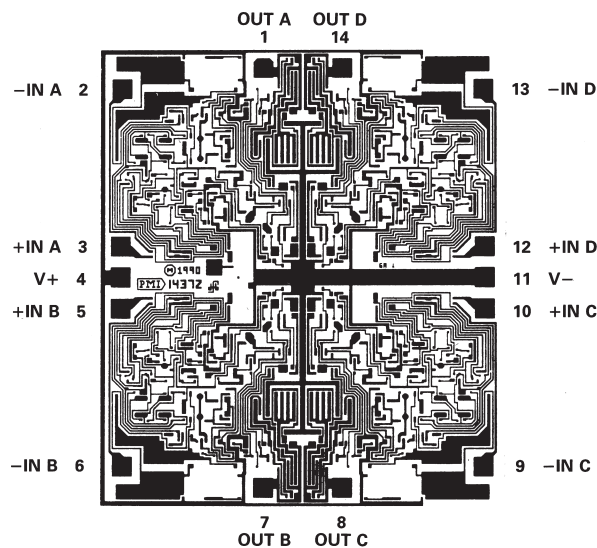

Die Size 0.112 × 0.129 inch, 14,448 sq. mils

CAUTION

ESD (electrostatic discharge) sensitive device. Electrostatic charges as high as 4000 V readily accumulate on the human body and test equipment and can discharge without detection. Although the OP497 features proprietary ESD protection circuitry, permanent damage may occur on devices subjected to high-energy electrostatic discharges. Therefore, proper ESD precautions are recommended to avoid performance degradation or loss of functionality.



OP497—Typical Performance Characteristics (25°C, $V_S = 15\text{ V}$, unless otherwise noted.)

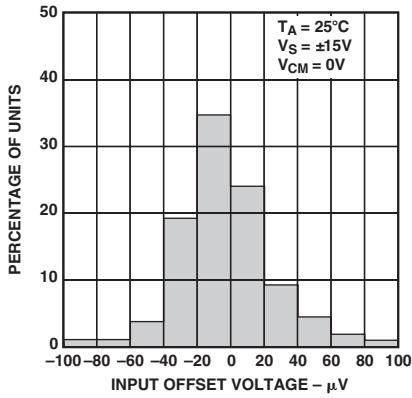

TPC 1. Typical Distribution of Input Offset Voltage

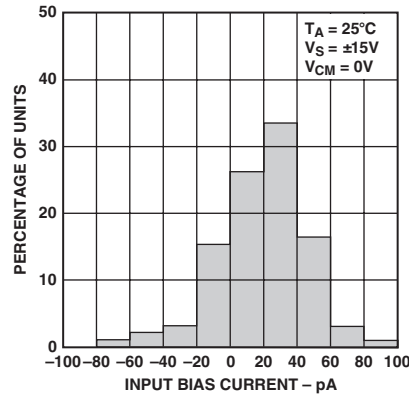

TPC 2. Typical Distribution of Input Bias Current

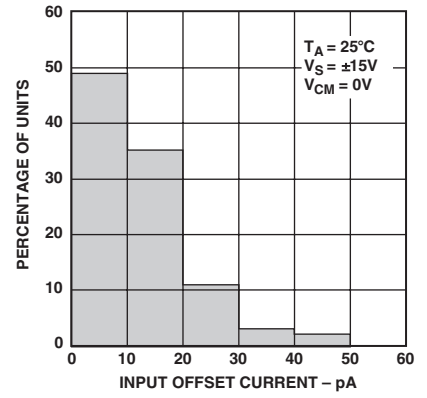

TPC 3. Typical Distribution of Input Offset Current

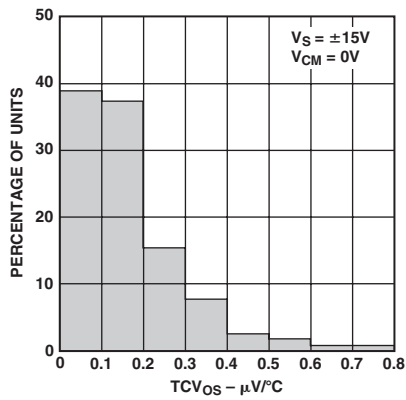

TPC 4. Typical Distribution of TCV_{OS}

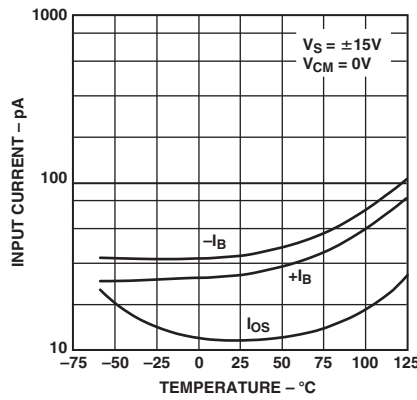

TPC 5. Input Bias, Offset Current vs. Temperature

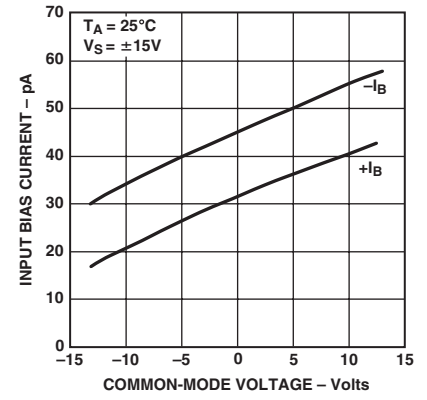

TPC 6. Input Bias Current vs. Common-Mode Voltage

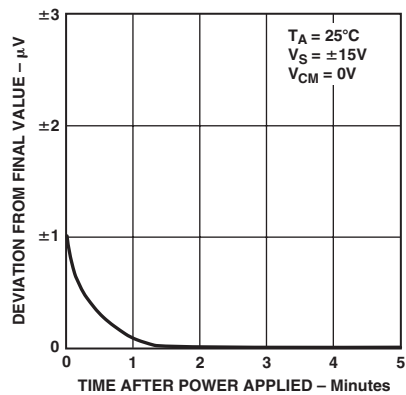

TPC 7. Input Offset Voltage Warm-Up Drift

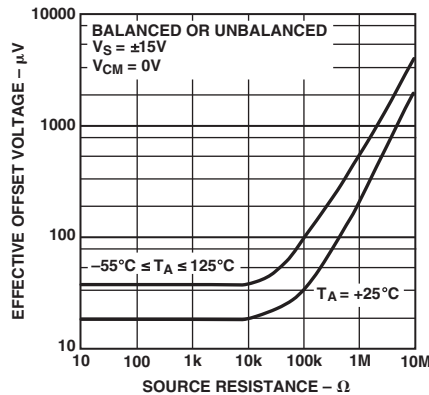

TPC 8. Effective Offset Voltage vs. Source Resistance

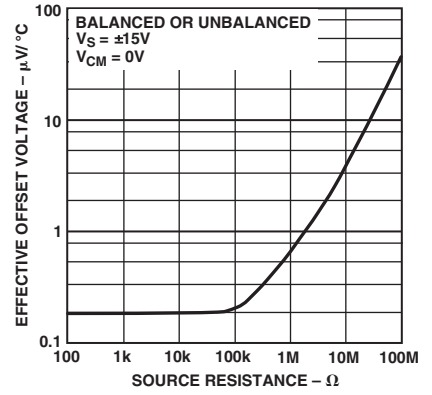

TPC 9. Effective TCV_{OS} vs. Source Resistance

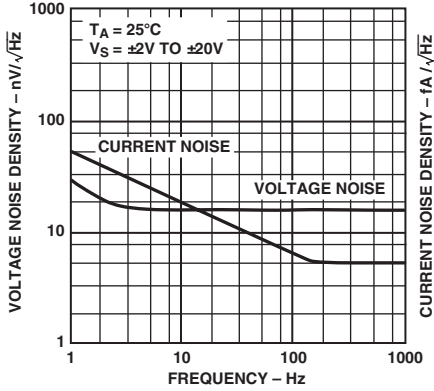

TPC 10. Voltage Noise Density vs. Frequency

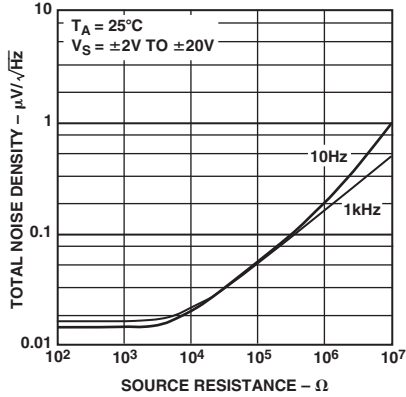

TPC 11. Total Noise Density vs. Source Resistance

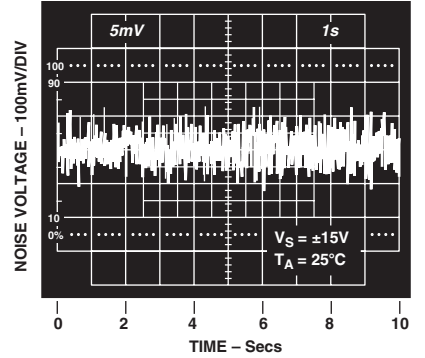

TPC 12. 0.1 Hz to 10 Hz Noise Voltage

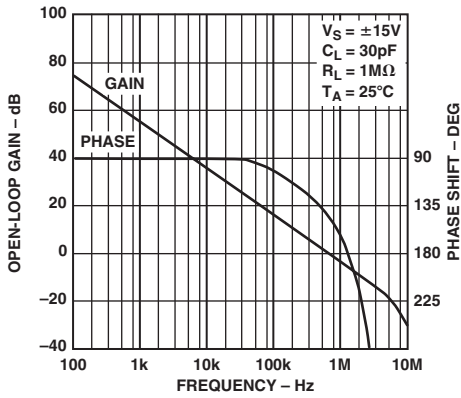

TPC 13. Open-Loop Gain, Phase vs. Frequency

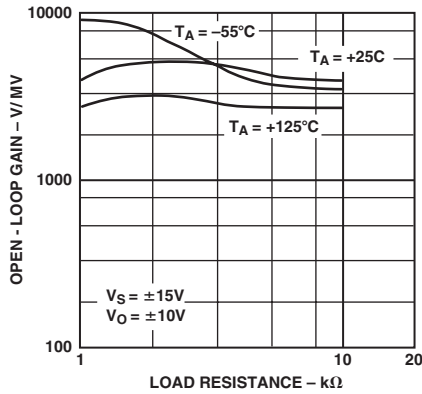

TPC 14. Open-Loop Gain vs. Load Resistance

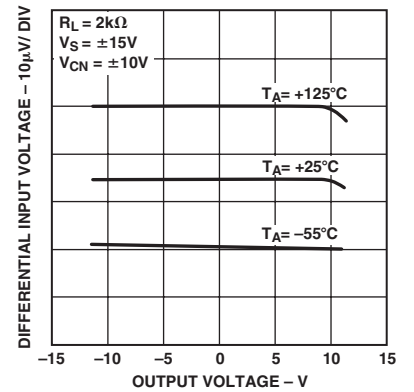

TPC 15. Open-Loop Gain Linearity

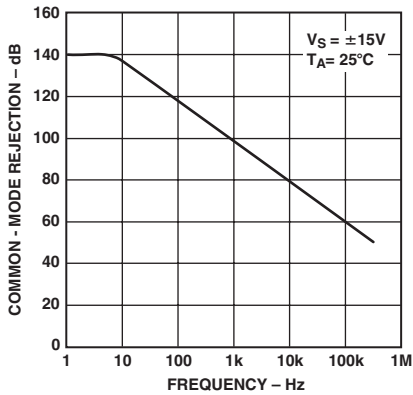

TPC 16. Common-Mode Rejection vs. Frequency

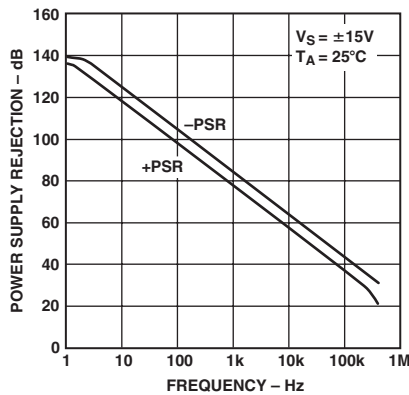

TPC 17. Power Supply Rejection vs. Frequency

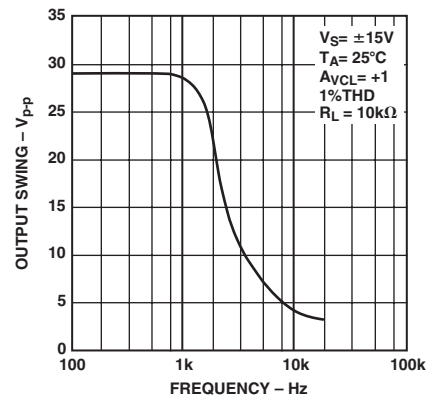

TPC 18. Maximum Output Swing vs. Frequency

OP497

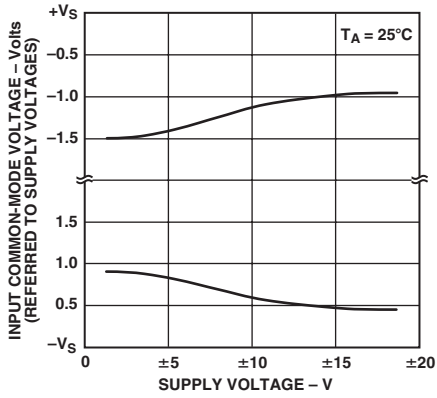

TPC 19. Input Common-Mode Voltage Range vs. Supply Voltage

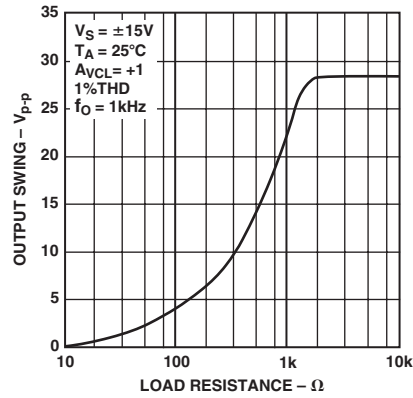

TPC 20. Maximum Output Swing vs. Load Resistance

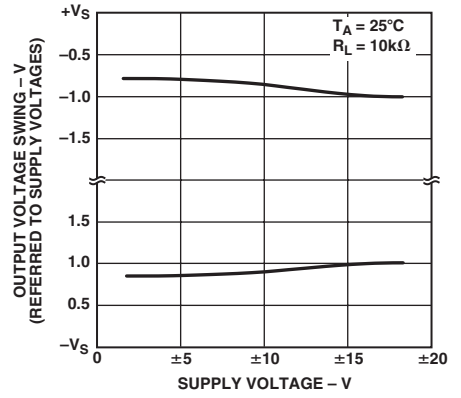

TPC 21. Output Voltage Swing vs. Supply Voltage

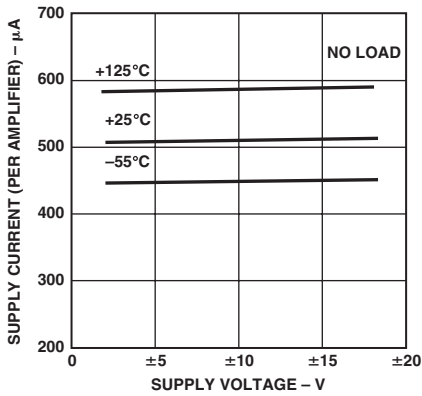

TPC 22. Supply Current (per Amplifier) vs. Supply Voltage

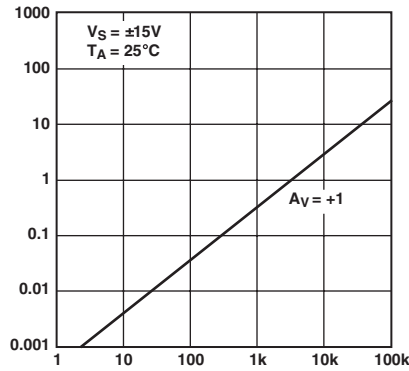

TPC 23. Closed-Loop Output Impedance vs. Frequency

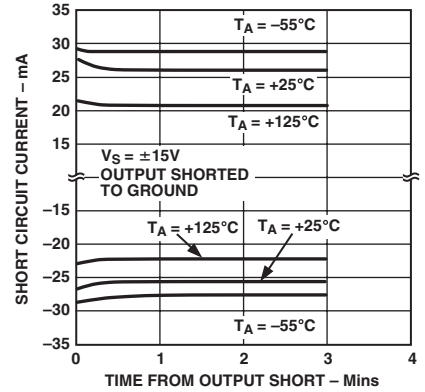

TPC 24. Short-Circuit Current vs. Time Temperature

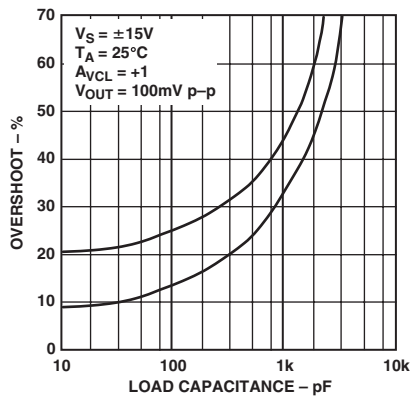

TPC 25. Small-Signal Overshoot vs. Capacitance Load

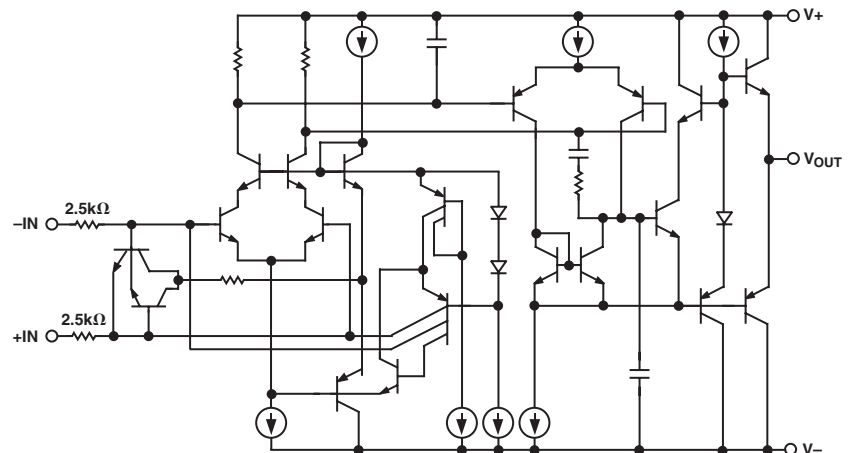

TPC 26. Simplified Schematic Showing One Amplifier

APPLICATIONS INFORMATION

Extremely low bias current over the full military temperature range makes the OP497 attractive for use in sample-and-hold amplifiers, peak detectors, and log amplifiers that must operate over a wide temperature range. Balancing input resistances is not necessary with the OP497. Offset voltage and TCV_{OS} are degraded only minimally by high source resistance, even when unbalanced.

The input pins of the OP497 are protected against large differential voltage by back-to-back diodes and current-limiting resistors. Common-mode voltages at the inputs are not restricted, and may vary over the full range of the supply voltages used.

The OP497 requires very little operating headroom about the supply rails, and is specified for operation with supplies as low as ± 2 V. Typically, the common-mode range extends to within 1 V of either rail. The output typically swings to within 1 V of the rails when using a 10 k Ω load.

AC PERFORMANCE

The OP497's ac characteristics are highly stable over its full operating temperature range. Unity-gain small-signal response is shown in Figure 1. Extremely tolerant of capacitive loading on the output, the OP497 displays excellent response even with 1000 pF loads (Figure 2).

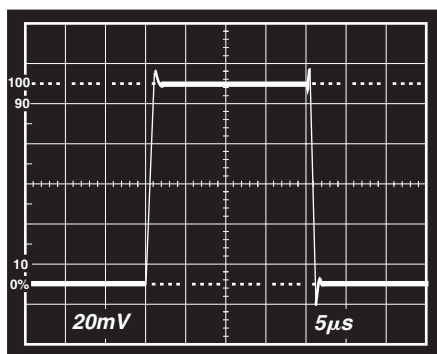

Figure 1. Small-Signal Transient Response ($C_{LOAD} = 100$ pF, $A_{VCL} = 1$)

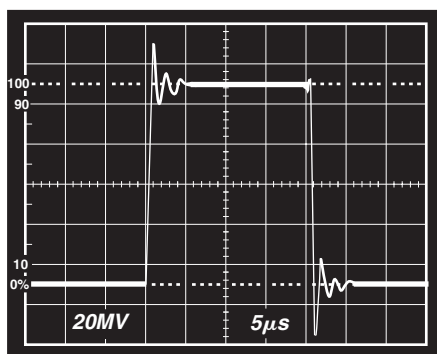

Figure 2. Small-Signal Transient Response ($C_{LOAD} = 1000$ pF, $A_{VCL} = 1$)

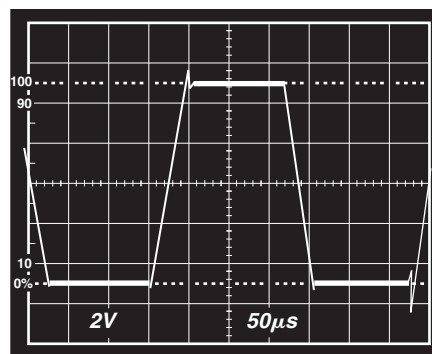

Figure 3. Large-Signal Transient Response ($A_{VCL} = 1$)

GUARDING AND SHIELDING

To maintain the extremely high input impedances of the OP497, care must be taken in circuit board layout and manufacturing. Board surfaces must be kept scrupulously clean and free of moisture. Conformal coating is recommended to provide a humidity barrier. Even a clean PC board can have 100 pA of leakage currents between adjacent traces, so guard rings should be used around the inputs. Guard traces are operated at a voltage close to that on the inputs, as shown in Figure 4, so that leakage currents become minimal. In noninverting applications, the guard ring should be connected to the common-mode voltage at the inverting input. In inverting applications, both inputs remain at ground, so the guard trace should be grounded. Guard traces should be on both sides of the circuit board.

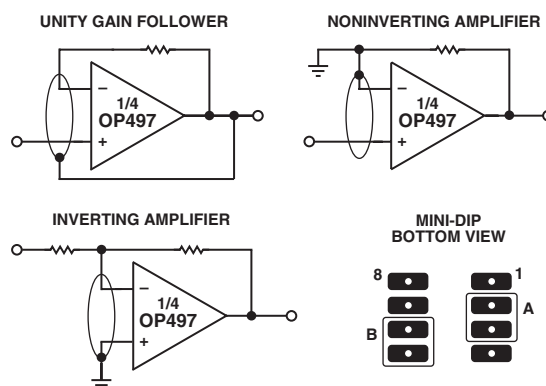

Figure 4. Guard Ring Layout and Connections

OP497

OPEN-LOOP GAIN LINEARITY

The OP497 has both an extremely high gain of 2000 V/mv minimum and constant gain linearity. This enhances the precision of the OP497 and provides for very high accuracy in high closed-loop gain applications. Figure 5 illustrates the typical open-loop gain linearity of the OP 497 over the military temperature range.

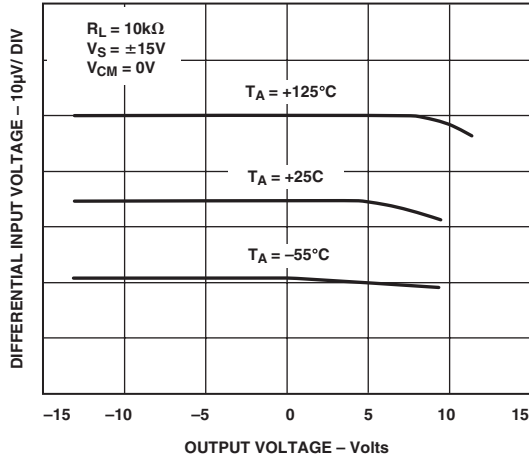

Figure 5. Open-Loop Linearity of the OP497

APPLICATIONS

Precision Absolute Value Amplifier

The circuit of Figure 6 is a precision absolute value amplifier with an input impedance of 30 MΩ. The high gain and low TCV_{OS} of the OP497 ensure accurate operation with microvolt input signals. In this circuit, the input always appears as a common-mode signal to the op amps. The CMR of the OP497 exceeds 120 dB, yielding an error of less than 2 ppm.

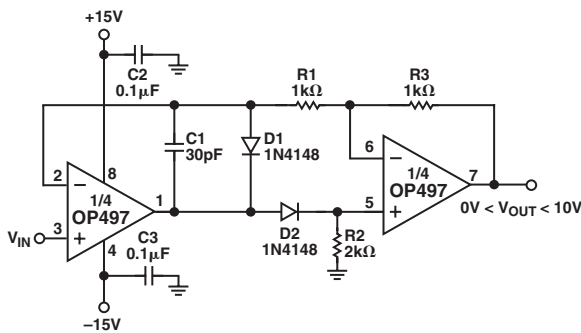

Figure 6. Precision Absolute Value Amplifier

Precision Current Pump

Maximum output current of the precision current pump shown in Figure 7 is $\pm 10\text{mA}$. Voltage compliance is $\pm 10\text{V}$ with $\pm 15\text{V}$ supplies. Output impedance of the current transmitter exceeds $3\text{M}\Omega$ with linearity better than 16 bits.

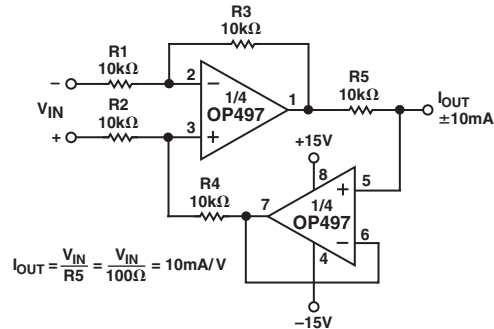

Figure 7. Precision Current Pump

Precision Positive Peak Detector

In Figure 8, the CH must be of polystyrene, Teflon*, or polyethylene to minimize dielectric absorption and leakage. The droop rate is determined by the size of CH and the bias current of the OP497.

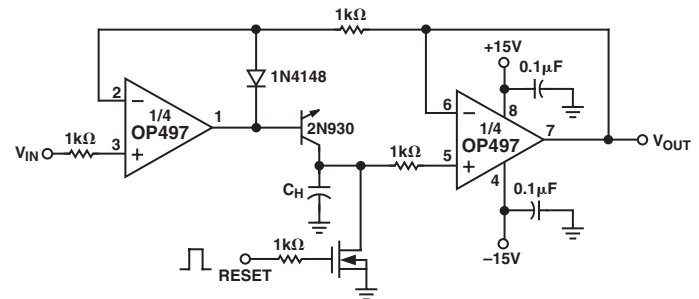

Figure 8. Precision Positive Peak Detector

Simple Bridge Conditioning Amplifier

Figure 9 shows a simple bridge conditioning amplifier using the OP497. The transfer function is:

$$V_{OUT} = V_{REF} \left(\frac{\Delta R}{R + \Delta R} \right) \frac{R_F}{R}$$

The REF43 provides an accurate and stable reference voltage for the bridge. To maintain the highest circuit accuracy, R_F should be 0.1% or better with a low temperature coefficient.

*Teflon is a registered trademark of the Dupont Company.

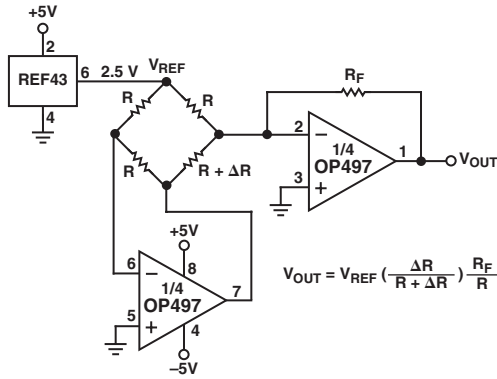

Figure 9. A Simple Bridge Conditioning Amplifier Using the OP497

NONLINEAR CIRCUITS

Due to its low input bias currents, the OP497 is an ideal log amplifier in nonlinear circuits such as the square and square root circuits shown in Figures 10 and 11. Using the squaring circuit of Figure 10 as an example, the analysis begins by writing a voltage-loop equation across transistors Q₁, Q₂, Q₃, and Q₄.

$$V_{T1} \ln\left(\frac{I_{IN}}{I_{S1}}\right) + V_{T2} \ln\left(\frac{I_{IN}}{I_{S2}}\right) = V_{T3} \ln\left(\frac{I_{O}}{I_{S3}}\right) + V_{T4} \ln\left(\frac{I_{REF}}{I_{S4}}\right)$$

All the transistors of the MAT04 are precisely matched and at the same temperature, so the I_s and V_T terms cancel, giving:

$$2 \ln I_{IN} = \ln I_{O} + \ln I_{REF} = \ln(I_{O} \times I_{REF})$$

Exponentiating both sides of thick equation leads to:

$$I_{O} = \frac{(I_{IN})^2}{I_{REF}}$$

Op amp A₂ forms a current-to-voltage converter which gives V_{OUT} = R₂ × I_O. Substituting (V_{IN}/R₁) for I_{IN} and the above equation for I_O, yields:

$$V_{OUT} = \left(\frac{R_2}{I_{REF}}\right) \left(\frac{V_{IN}}{R_1}\right)^2$$

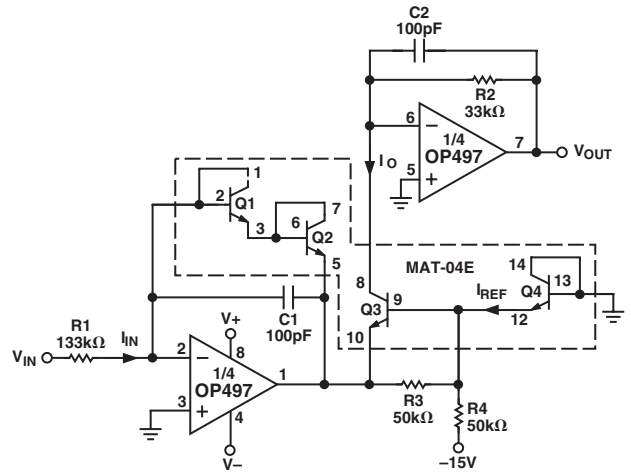

Figure 10. Squaring Amplifier

A similar analysis made for the square-root circuit of Figure 11 leads to its transfer function:

$$V_{OUT} = R_2 \sqrt{\frac{(V_{IN})(I_{REF})}{R_1}}$$

In these circuits, I_{REF} is a function of the negative power supply. To maintain accuracy, the negative supply should be well regulated. For applications where very high accuracy is required, a voltage reference may be used to set I_{REF}. An important consideration for the squaring circuit is that a sufficiently large input voltage can force the output beyond the operating range of the output op amp. Resistor R₄ can be changed to scale I_{REF}, or R₁ and R₂ can be varied to keep the output voltage within the usable range.

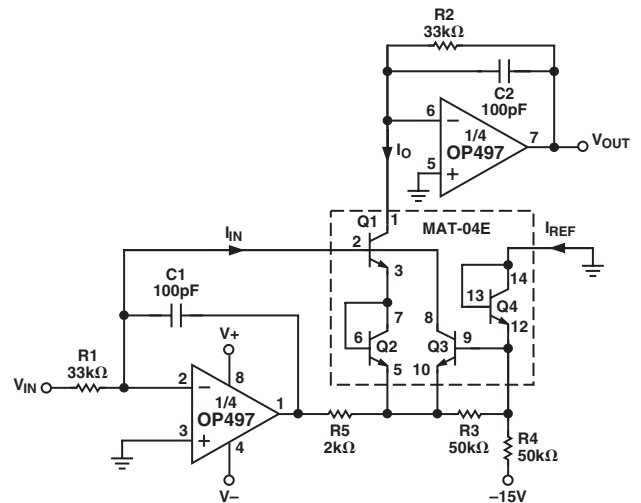

Figure 11. Square-Root Amplifier

Unadjusted accuracy of the square-root circuit is better than 0.1% over an input voltage range of 100 mV to 10 V. For a similar input voltage range, the accuracy of the squaring circuit is better than 0.5%.

OP497

OP497 SPICE MACRO-MODEL

Figure 12 and Table I show the node and net list for a SPICE macro-model of the OP497. The model is a simplified version of the actual device and simulates important dc parameters such as V_{OS} , I_{OS} , I_B , A_{VO} , CMR , V_O , and I_{SY} . AC parameters such as slew rate, gain and phase response, and CMR change with frequency are also simulated by the model.

The model uses typical parameters for the OP497. The poles and zeros in the model were determined from the actual open and closed-loop gain and phase response of the OP497. In this way, the model presents an accurate ac representation of the actual device. The model assumes an ambient temperature of 25°C.

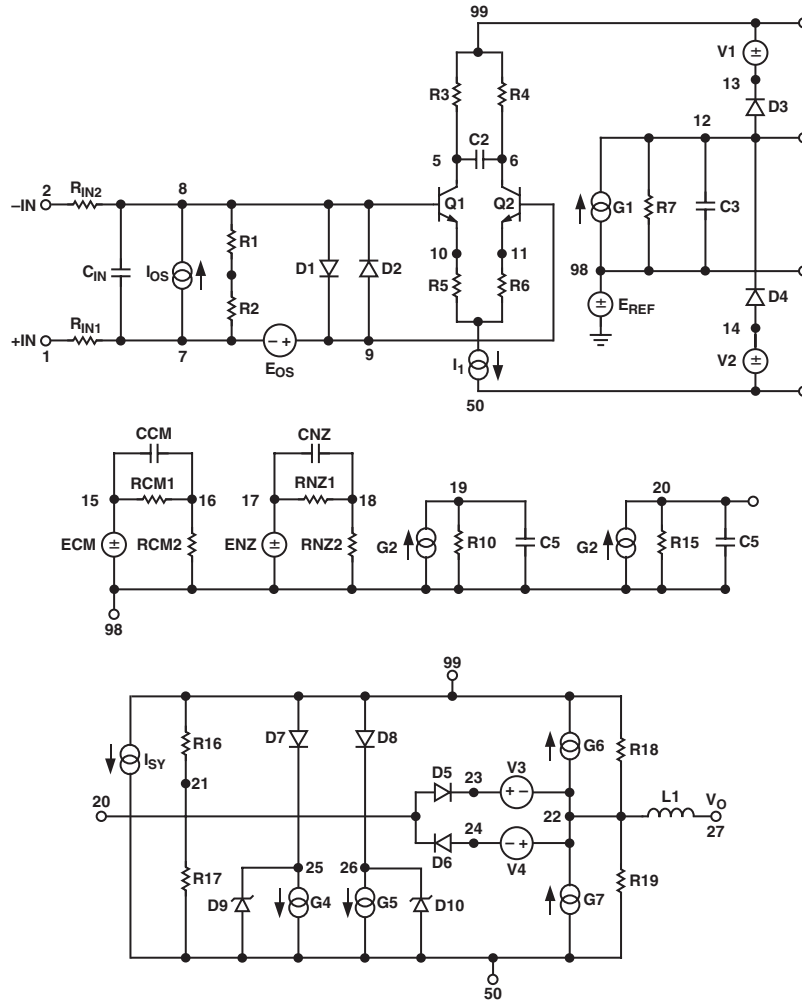

Figure 12. OP497 Macro Model

Table I. OP497 SPICE Net-List

```

* Node assignments
*           noninverting input
*           inverting input
*           positive supply
*           negative supply
*           output
*SUBCKT OP497 1 2 99 50 27
*
* INPUT STAGE AND POLE AT 6 MHz
*
RIN1 1 7 2500
RIN2 2 8 2500
R1 8 3 6.782E8
R2 7 3 6.782E8
R3 5 99 542.57
R4 6 99 542.57
CIN 7 8 3E-12
C2 5 6 24.445E-12
I1 4 50 0.1E-3
IOS 7 8 15E-12
EOS 9 7 POLY(1) 16 21 40E-6 1
Q1 5 8 10 QX
Q2 6 9 11 QX
R5 10 4 25.374
R6 11 4 25.374
D1 8 9 DX
D2 9 8 DX
*
EREF98 0 21 0 1
*
*GAIN STAGE AND DOMINANT POLE AT 0.11 Hz
*
R7 1 98 2.1703E9
C3 2 98 666.67E-12
G1 98 12 5
V1 99 13 1.275
V2 11 9 1.275
D3 12 13 DX
D4 14 12 DX
*
*COMMON-MODE GAIN NETWORK WITH ZERO AT 50 MHz
*
RCM1 15 16 1E6
CCM 15 16 3.18E-9
RCM2 16 98 1
ECM 15 98 3 21 177.83E-3

* NEGATIVE ZERO AT 1.8 MHz
*
E1 17 98 12 21 1E6
R8 17 18 1E6
C4 17 18 -88.419E-15
R9 18 98 1
*
* POLE AT 6 MHz
*
G2 98 19 18 21 1E-6
R15 20 98 1E6
C8 20 98 26.526E-15
*
* POLE AT 1.8 MHz
*
G6 98 20 19 21 1E-6
R20 20 98 1E6
C10 20 98 88.419E-15
*
* OUTPUT STAGE
*
R16 99 21 160 k
R17 21 50 160 k
ISY 99 50 331E-6
V3 23 22 1.9
D5 20 23 DX
V4 22 24 1.9
D6 24 20 DX
D7 99 25 DX
G4 25 50 20 22 5E-3
D9 50 25 DY
D8 99 26 DX
G5 26 50 22 20 5E-3
D10 50 26 DY
G6 22 99 99 20 5E-3
R18 99 22 200
G7 50 22 20 50 5E-3
R19 22 50 200
L1 22 27 0.1E-6
*
* MODELS USED
*
.MODEL QX NPN (BF = 1.25E6)
.MODEL DX (IS = 1E-15)
.MODEL DZ D(IS = 1E-15 BV = 50)
.ENDS OP497

```

OUTLINE DIMENSIONS
Dimensions shown in inches and (mm).

**14-Lead Ceramic DIP
(Y-Suffix)**

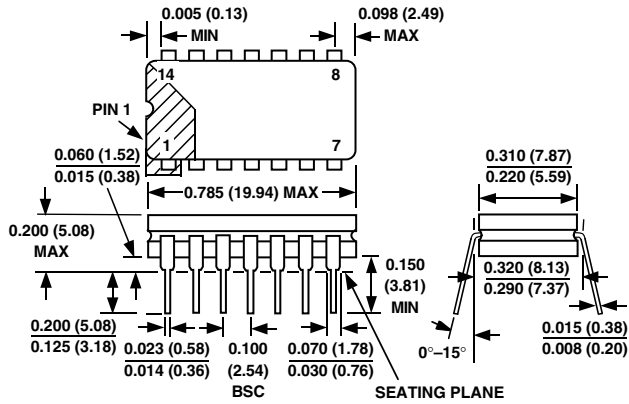

**16-Lead Wide-Body SOIC
(S-Suffix)**

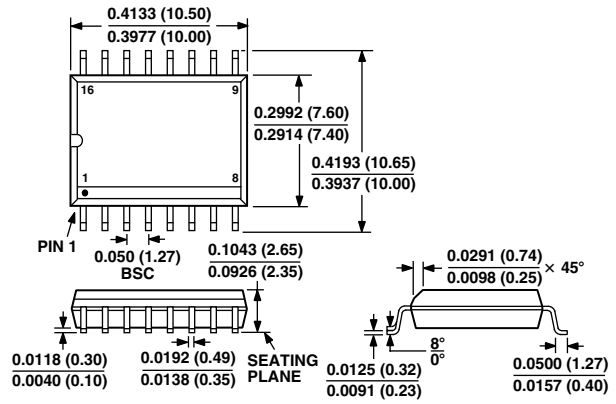

**14-Lead Epoxy DIP
(P-Suffix)**

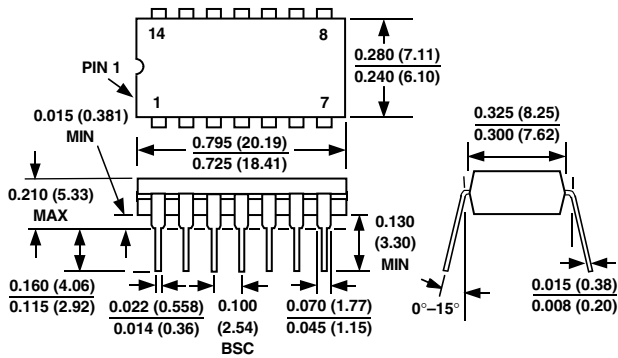

Revision History

Location	Page
11/01—Data Sheet changed from REV. C to REV. D.	
Edits to PIN CONNECTIONS headings	1
Deleted WAFER TEST LIMITS	3
Edits to ORDERING GUIDE	3
Edits to ABSOLUTE MAXIMUM RATINGS	3
Edits to OUTLINE DIMENSIONS	12



LittleDiode supplies new, hard to find or obsolete electronic components and semiconductors all over the world.

With over two million different components listed you are sure to find the part you need.

Feel free to visit us today at our online store:

LittleDiode.com

Looking forward to providing you with the best possible service.