

## Fast IGBT & FRED

The Fast IGBT™ is a new generation of high voltage power IGBTs. Using Non-Punch Through™ Technology the Fast IGBT™ combined with an APT free-wheeling ultraFast Recovery Epitaxial Diode (FRED) offers superior ruggedness and fast switching speed.

- Low Forward Voltage Drop
- Low Tail Current
- RBSOA and SCSOA Rated
- Ultrafast Soft Recovery Antiparallel Diode
- High Freq. Switching to 20KHz
- Ultra Low Leakage Current

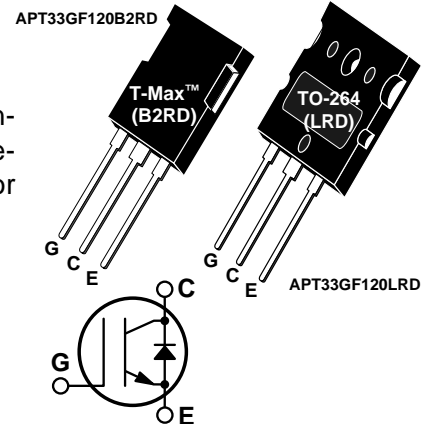

### MAXIMUM RATINGS (IGBT)

All Ratings:  $T_C = 25^\circ\text{C}$  unless otherwise specified.

Symbol	Parameter	APT33GF120B2RD/LRD	UNIT
$V_{CES}$	Collector-Emitter Voltage	1200	Volts
$V_{CGR}$	Collector-Gate Voltage ( $R_{GE} = 20K\Omega$ )	1200	
$V_{GE}$	Gate-Emitter Voltage	$\pm 20$	
$I_{C1}$	Continuous Collector Current @ $T_C = 25^\circ\text{C}$	52	Amps
$I_{C2}$	Continuous Collector Current @ $T_C = 90^\circ\text{C}$	33	
$I_{CM1}$	Pulsed Collector Current <sup>①</sup> @ $T_C = 25^\circ\text{C}$	104	
$I_{CM2}$	Pulsed Collector Current <sup>①</sup> @ $T_C = 90^\circ\text{C}$	66	
$P_D$	Total Power Dissipation	300	Watts
$T_J, T_{STG}$	Operating and Storage Junction Temperature Range	-55 to 150	$^\circ\text{C}$
$T_L$	Max. Lead Temp. for Soldering: 0.063" from Case for 10 Sec.	300	

### STATIC ELECTRICAL CHARACTERISTICS (IGBT)

Symbol	Characteristic / Test Conditions	MIN	TYP	MAX	UNIT
$BV_{CES}$	Collector-Emitter Breakdown Voltage ( $V_{GE} = 0V, I_C = 0.5mA$ )	1200			Volts
$V_{GE(TH)}$	Gate Threshold Voltage ( $V_{CE} = V_{GE}, I_C = 700\mu A, T_J = 25^\circ\text{C}$ )	4.5	5.5	6.5	
$V_{CE(ON)}$	Collector-Emitter On Voltage ( $V_{GE} = 15V, I_C = 25A, T_J = 25^\circ\text{C}$ )		2.7	3.2	
	Collector-Emitter On Voltage ( $V_{GE} = 15V, I_C = 25A, T_J = 125^\circ\text{C}$ )		3.3	3.9	
$I_{CES}$	Collector Cut-off Current ( $V_{CE} = V_{CES}, V_{GE} = 0V, T_J = 25^\circ\text{C}$ ) <sup>②</sup>			0.5	mA
	Collector Cut-off Current ( $V_{CE} = V_{CES}, V_{GE} = 0V, T_J = 125^\circ\text{C}$ ) <sup>②</sup>			5.0	
$I_{GES}$	Gate-Emitter Leakage Current ( $V_{GE} = \pm 20V, V_{CE} = 0V$ )			$\pm 100$	nA

 **CAUTION:** These Devices are Sensitive to Electrostatic Discharge. Proper Handling Procedures Should Be Followed.

**USA**  
405 S.W. Columbia Street

**EUROPE**  
Avenue J.F. Kennedy Bât B4 Parc Cadéra Nord

APT Website - <http://www.advancedpower.com>

Bend, Oregon 97702-1035

Phone: (541) 382-8028

FAX: (541) 388-0364

F-33700 Merignac - France

Phone: (33) 5 57 92 15 15

FAX: (33) 5 56 47 97 61

**DYNAMIC CHARACTERISTICS (IGBT)**
**APT33GF120B2RD/LRD**

Symbol	Characteristic	Test Conditions	MIN	TYP	MAX	UNIT
$C_{ies}$	Input Capacitance	<b>Capacitance</b> $V_{GE} = 0V$ $V_{CE} = 25V$ $f = 1\text{ MHz}$		1650	2200	pF
$C_{oes}$	Output Capacitance			230	325	
$C_{res}$	Reverse Transfer Capacitance			110	160	
$Q_g$	Total Gate Charge <sup>③</sup>	<b>Gate Charge</b> $V_{GE} = 15V$ $V_{CC} = 0.5V_{CES}$ $I_C = I_{C2}$		165	250	nC
$Q_{ge}$	Gate-Emitter Charge			20	30	
$Q_{gc}$	Gate-Collector ("Miller") Charge			100	150	
$t_{d(on)}$	Turn-on Delay Time	<b>Resistive Switching (25°C)</b> $V_{GE} = 15V$ $V_{CC} = 0.8V_{CES}$ $I_C = I_{C2}$ $R_G = 10\Omega$		30		ns
$t_r$	Rise Time			140		
$t_{d(off)}$	Turn-off Delay Time			155		
$t_f$	Fall Time			200		
$t_{d(on)}$	Turn-on Delay Time	<b>Inductive Switching (150°C)</b> $V_{CLAMP(Peak)} = 0.66V_{CES}$ $V_{GE} = 15V$ $I_C = I_{C2}$ $R_G = 10\Omega$ $T_J = +150^\circ C$		28		ns
$t_r$	Rise Time			60		
$t_{d(off)}$	Turn-off Delay Time			280		
$t_f$	Fall Time			30		
$E_{on}$	Turn-on Switching Energy <sup>④</sup>			3.0		mJ
$E_{off}$	Turn-off Switching Energy			3.0		
$E_{ts}$	Total Switching Losses <sup>④</sup>			6.0		
$t_{d(on)}$	Turn-on Delay Time	<b>Inductive Switching (25°C)</b> $V_{CLAMP(Peak)} = 0.66V_{CES}$ $V_{GE} = 15V$ $I_C = I_{C2}$ $R_G = 10\Omega$ $T_J = +25^\circ C$		28		ns
$t_r$	Rise Time			70		
$t_{d(off)}$	Turn-off Delay Time			250		
$t_f$	Fall Time			25		
$E_{ts}$	Total Switching Losses <sup>④</sup>			5.0		mJ
gfe	Forward Transconductance	$V_{CE} = 20V, I_C = 25A$	8.5	20		S

**THERMAL AND MECHANICAL CHARACTERISTICS (IGBT and FRED)**

Symbol	Characteristic	MIN	TYP	MAX	UNIT
$R_{\theta JC}$	Junction to Case (IGBT)			0.42	°C/W
	Junction to Case (FRED)			0.90	
$R_{\theta JA}$	Junction to Ambient			40	
$W_T$	Package Weight		0.22		oz
			6.1		gm
Torque	Mounting Torque using a 6-32 or 3mm Binding Head Machine Screw			10	lb•in
				1.1	N•m

① Repetitive Rating: Pulse width limited by maximum junction temperature.

② Leakages include the FRED and IGBT.

③ See MIL-STD-750 Method 3471

④ Switching losses include the FRED and IGBT.

**APT Reserves the right to change, without notice, the specifications and information contained herein.**

**Power dissipation**

$$P_{\text{tot}} = f(T_C)$$

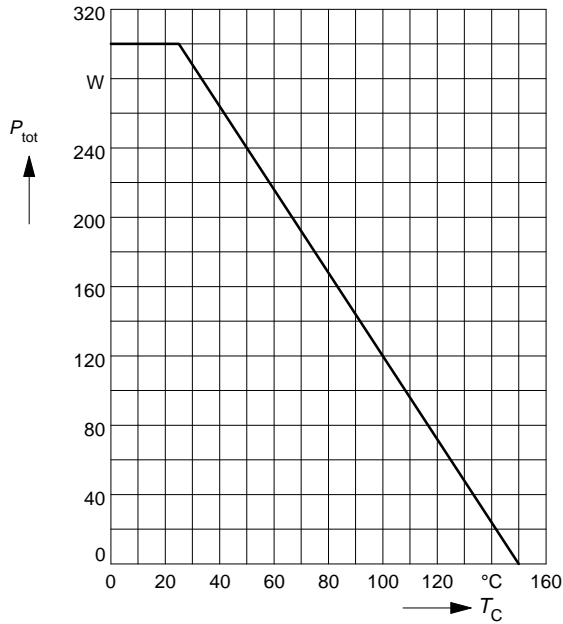
 parameter:  $T_j \leq 150\text{ }^\circ\text{C}$ 

**Collector current**

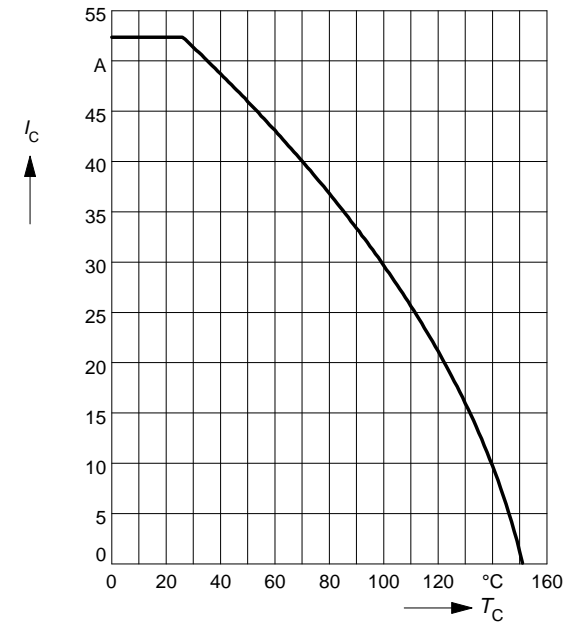
$$I_C = f(T_C)$$

 parameter:  $V_{GE} \geq 15\text{ V}$ ,  $T_j \leq 150\text{ }^\circ\text{C}$ 

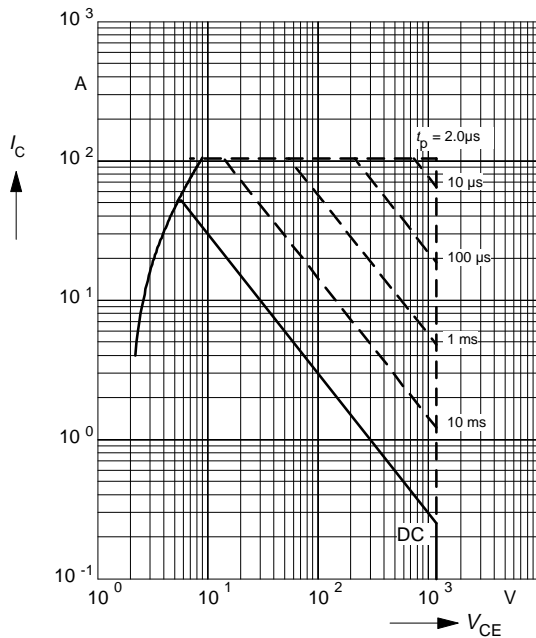
**Safe operating area**

$$I_C = f(V_{CE})$$

 parameter:  $D = 0$ ,  $T_C = 25\text{ }^\circ\text{C}$ ,  $T_j \leq 150\text{ }^\circ\text{C}$ 

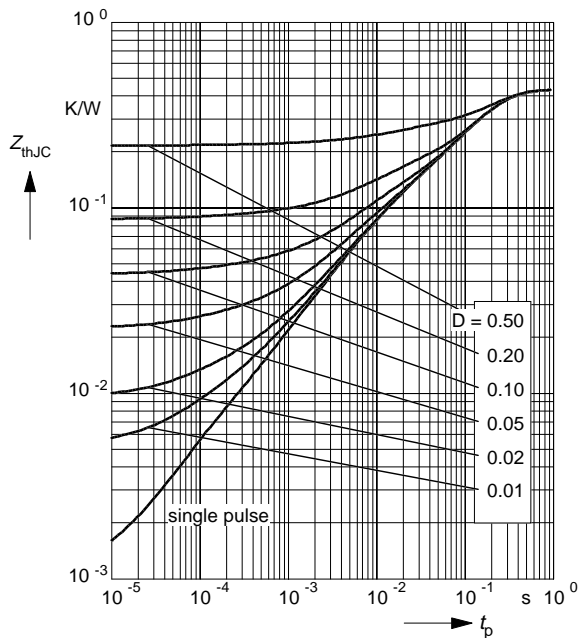
**Transient thermal impedance IGBT**

$$Z_{\text{thJC}} = f(t_p)$$

 parameter:  $D = t_p / T$ 

**EUROPE**

 Avenue J.F. Kennedy Bât B4 Parc Cadéra Nord  
**USA**

405 S.W. Columbia Street

F-33700 Merignac - France

Bend, Oregon 97702-1035

Phone: (33) 5 57 92 15 15

Phone: (541) 382-8028

FAX: (33) 5 56 47 97 61

FAX: (541) 388-0364

**Typ. output characteristics**

$$I_C = f(V_{CE})$$

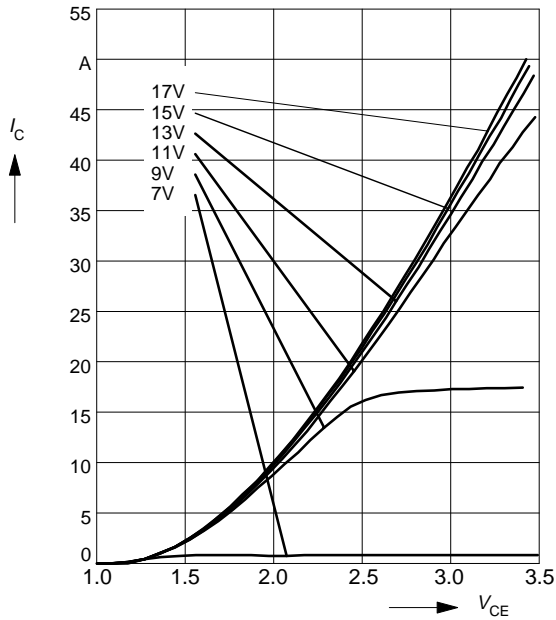
 parameter:  $t_p = 80 \mu s$ ,  $T_j = 25 \text{ }^\circ\text{C}$ 

**Typ. output characteristics**

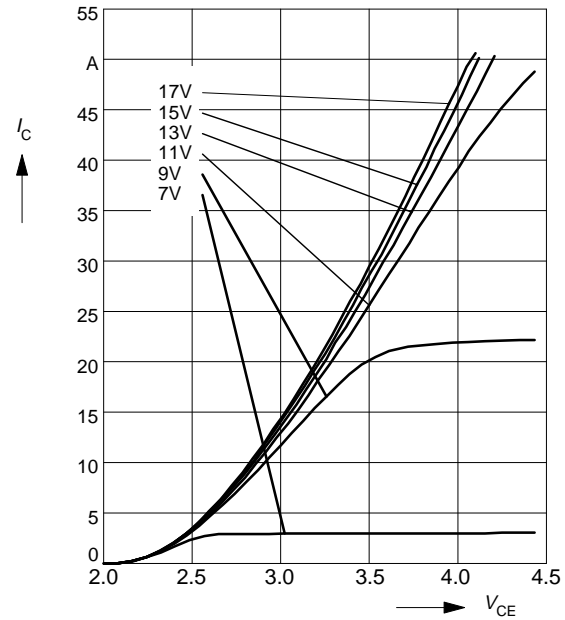
$$I_C = f(V_{CE})$$

 parameter:  $t_p = 80 \mu s$ ,  $T_j = 125 \text{ }^\circ\text{C}$ 

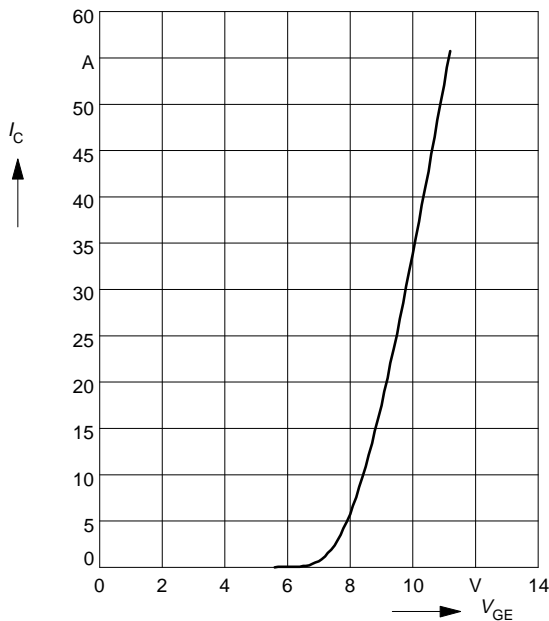
**Typ. transfer characteristics**

$$I_C = f(V_{GE})$$

 parameter:  $t_p = 80 \mu s$ ,  $V_{CE} = 20 \text{ V}$ 

**EUROPE**

Avenue J.F. Kennedy Bât B4 Parc Cadéra Nord

**USA**

405 S.W. Columbia Street

F-33700 Merignac - France

Bend, Oregon 97702-1035

Phone: (33) 5 57 92 15 15

Phone: (541) 382-8028

FAX: (33) 5 56 47 97 61

FAX: (541) 388-0364

**Typ. gate charge**

$V_{GE} = f(Q_{Gate})$

parameter:  $I_{C\ puls} = 26A$

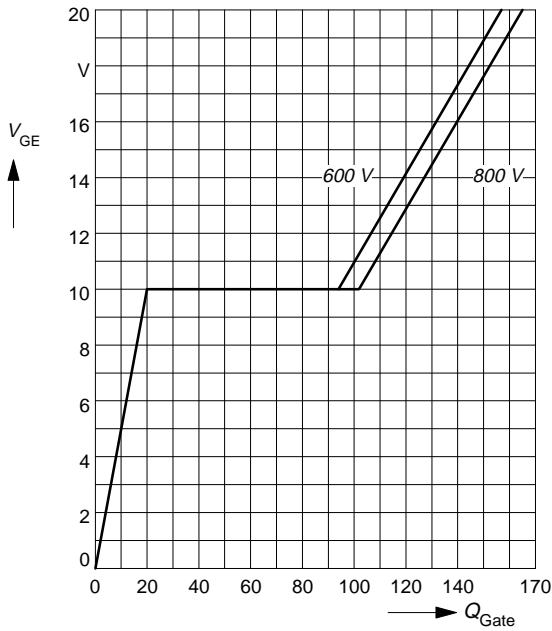

**Typ. capacitances**

$C = f(V_{CE})$

parameter:  $V_{GE} = 0V, f = 1\ MHz$

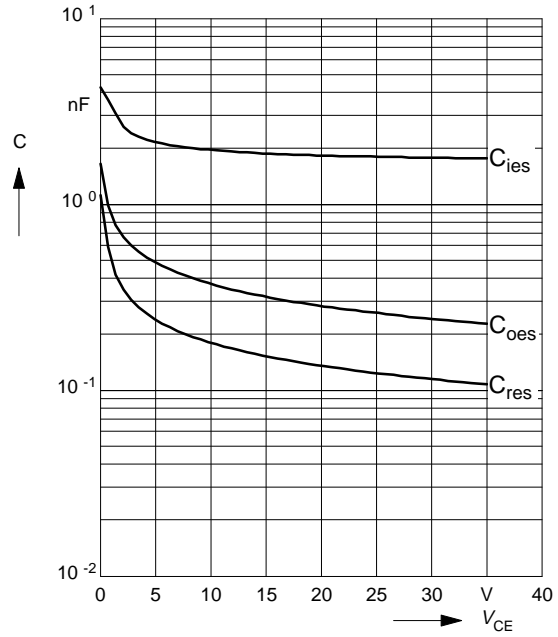

**Short circuit safe operating area**

$I_{Csc} = f(V_{CE}), T_j = 150^\circ C$

parameter:  $V_{GE} = \pm 15V, t_{sc} \le 10\ \mu s, L < 25\ nH$

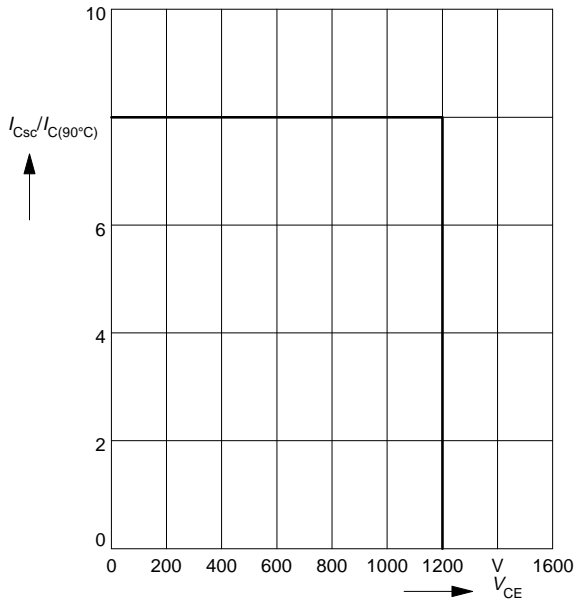

**Reverse biased safe operating area**

$I_{Cpuls} = f(V_{CE}), T_j = 150^\circ C$

parameter:  $V_{GE} = 15V$

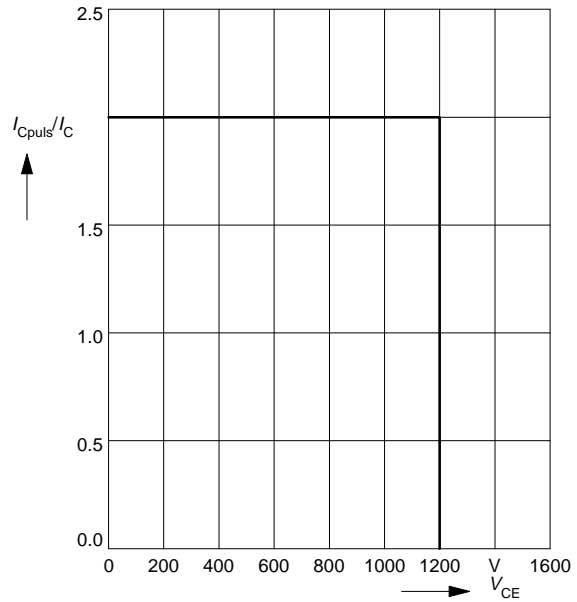

# ULTRAFAST SOFT RECOVERY PARALLEL DIODE

**MAXIMUM RATINGS (FRED)**

All Ratings:  $T_C = 25^\circ\text{C}$  unless otherwise specified.

Symbol	Characteristic / Test Conditions	APT33GF120B2RD/LRD	UNIT
$V_R$	Maximum D.C. Reverse Voltage	1200	Volts
$V_{RRM}$	Maximum Peak Repetitive Reverse Voltage		
$V_{RWM}$	Maximum Working Peak Reverse Voltage		
$I_F(AV)$	Maximum Average Forward Current ( $T_C = 85^\circ\text{C}$ , Duty Cycle = 0.5)	30	Amps
$I_F(RMS)$	RMS Forward Current	70	
$I_{FSM}$	Non-Repetitive Forward Surge Current ( $T_J = 45^\circ\text{C}$ , 8.3ms)	210	

**STATIC ELECTRICAL CHARACTERISTICS (FRED)**

Symbol	Characteristic / Test Conditions	MIN	TYP	MAX	UNIT
$V_F$	Maximum Forward Voltage		2.0	2.5	Volts
				$I_F = 30\text{A}$	
				$I_F = 60\text{A}$	
	$I_F = 30\text{A}, T_J = 150^\circ\text{C}$			2.0	

**DYNAMIC CHARACTERISTICS (FRED)**

Symbol	Characteristic	MIN	TYP	MAX	UNIT
$t_{rr1}$	Reverse Recovery Time, $I_F = 1.0\text{A}$ , $di_F/dt = -15\text{A}/\mu\text{s}$ , $V_R = 30\text{V}$ , $T_J = 25^\circ\text{C}$		70	85	ns
$t_{rr2}$	Reverse Recovery Time		$T_J = 25^\circ\text{C}$ 70		
$t_{rr3}$	$I_F = 30\text{A}$ , $di_F/dt = -240\text{A}/\mu\text{s}$ , $V_R = 650\text{V}$		$T_J = 100^\circ\text{C}$ 160		
$t_{fr1}$	Forward Recovery Time		$T_J = 25^\circ\text{C}$ 255		Volts
$t_{fr2}$	$I_F = 30\text{A}$ , $di_F/dt = 240\text{A}/\mu\text{s}$ , $V_R = 650\text{V}$		$T_J = 100^\circ\text{C}$ 255		
$I_{RRM1}$	Reverse Recovery Current		$T_J = 25^\circ\text{C}$ 7	12	Amps
$I_{RRM2}$	$I_F = 30\text{A}$ , $di_F/dt = -240\text{A}/\mu\text{s}$ , $V_R = 650\text{V}$		$T_J = 100^\circ\text{C}$ 12	20	
$Q_{rr1}$	Recovery Charge		$T_J = 25^\circ\text{C}$ 660		nC
$Q_{rr2}$	$I_F = 30\text{A}$ , $di_F/dt = -240\text{A}/\mu\text{s}$ , $V_R = 650\text{V}$		$T_J = 100^\circ\text{C}$ 1640		
$V_{fr1}$	Forward Recovery Voltage		$T_J = 25^\circ\text{C}$ 15		Volts
$V_{fr2}$	$I_F = 30\text{A}$ , $di_F/dt = 240\text{A}/\mu\text{s}$ , $V_R = 650\text{V}$		$T_J = 100^\circ\text{C}$ 20		
$diM/dt$	Rate of Fall of Recovery Current		$T_J = 25^\circ\text{C}$ 245		A/ $\mu\text{s}$
	$I_F = 30\text{A}$ , $di_F/dt = -240\text{A}/\mu\text{s}$ , $V_R = 650\text{V}$		$T_J = 100^\circ\text{C}$ 160		

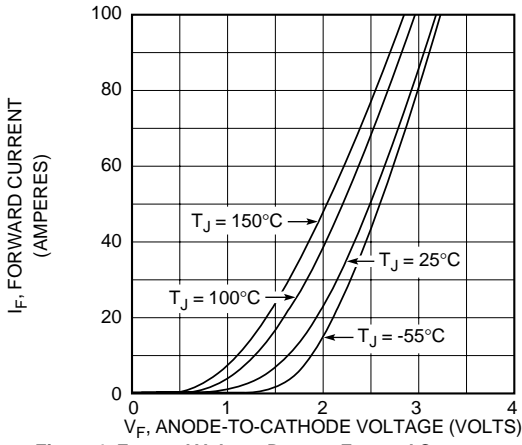

Figure 1, Forward Voltage Drop vs Forward Current

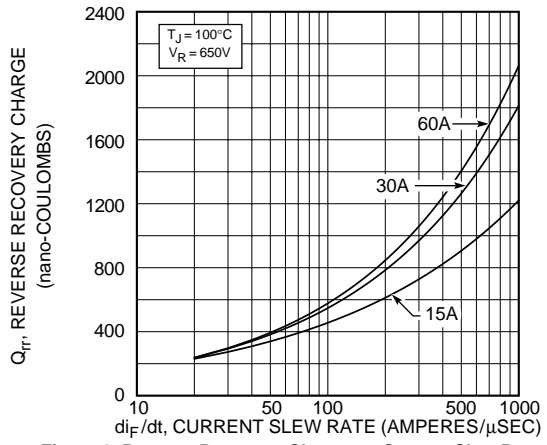

Figure 2, Reverse Recovery Charge vs Current Slew Rate

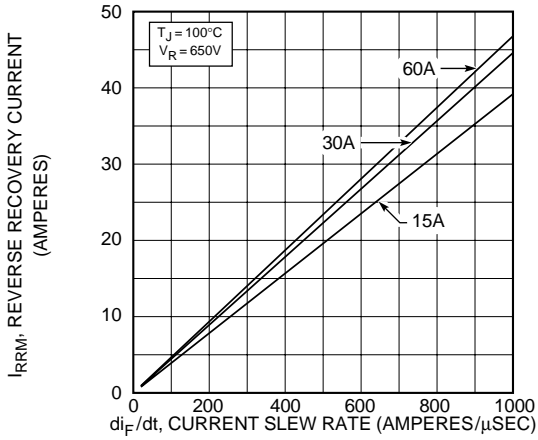

Figure 3, Reverse Recovery Current vs Current Slew Rate

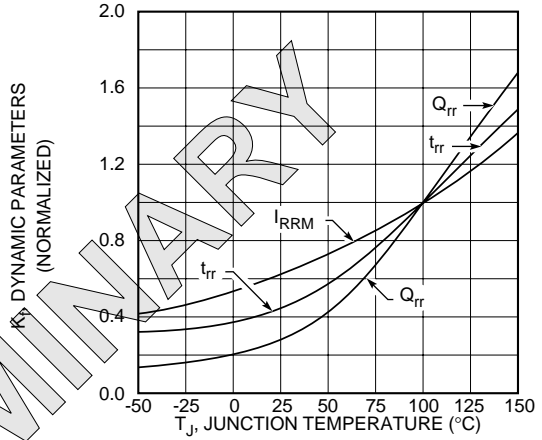

Figure 4, Dynamic Parameters vs Junction Temperature

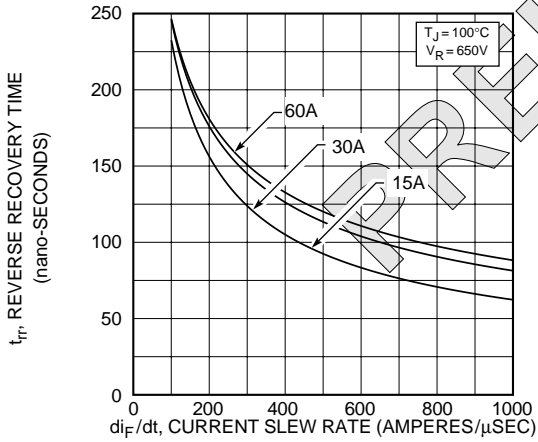

Figure 5, Reverse Recovery Time vs Current Slew Rate

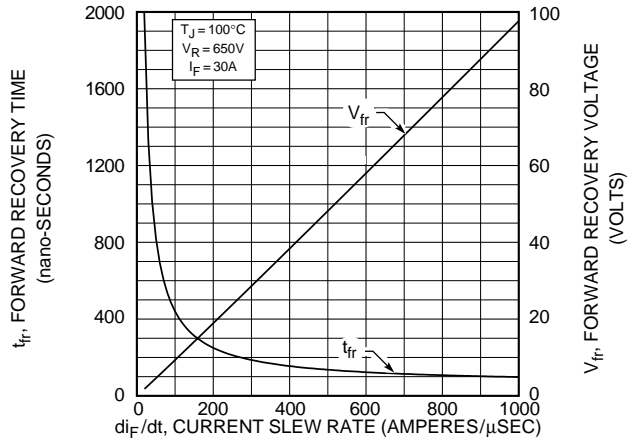

Figure 6, Forward Recovery Voltage/Time vs Current Slew Rate

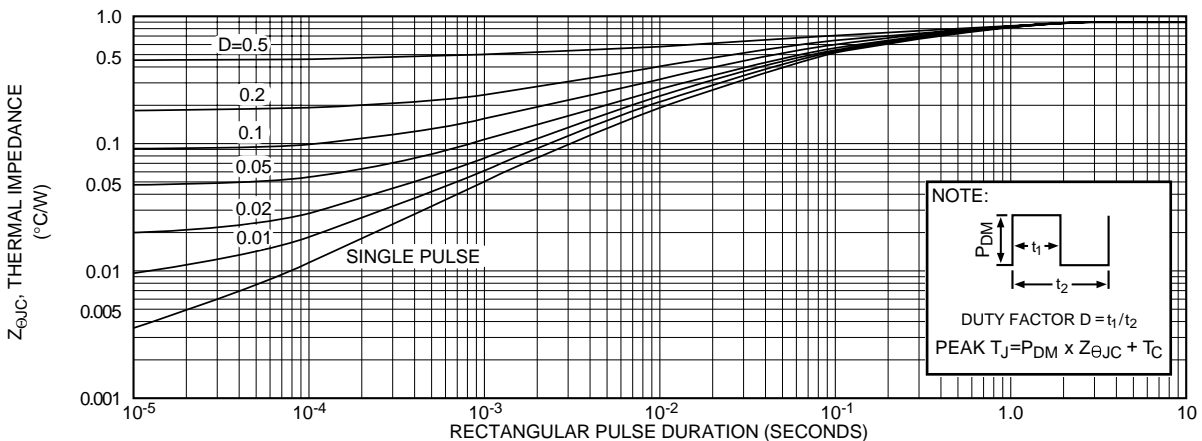

Figure 7, Maximum Effective Transient Thermal Impedance, Junction-To-Case vs Pulse Duration

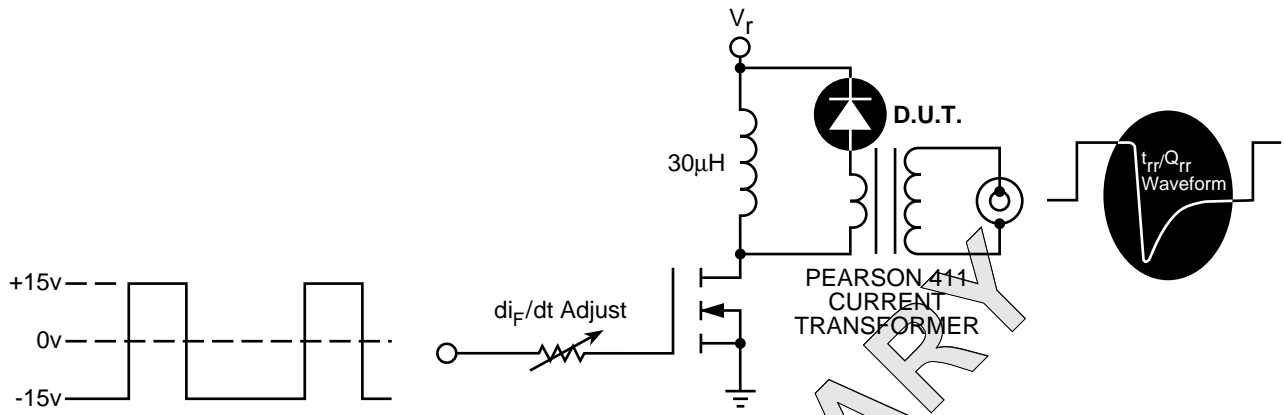

Figure 25, Diode Reverse Recovery Test Circuit and Waveforms

1  $I_F$  - Forward Conduction Current

2  $di_F/dt$  - Current Slew Rate, Rate of Forward Current Change Through Zero Crossing

3  $I_{RRM}$  - Peak Reverse Recovery Current.

4  $t_{rr}$  - Reverse Recovery Time Measured from Point of  $I_F$  Current Falling Through Zero to a Tangent Line { 6  $diM/dt$  } Extrapolated Through Zero Defined by 0.75 and 0.50  $I_{RRM}$ .

5  $Q_{rr}$  - Area Under the Curve Defined by  $I_{RRM}$  and  $t_{rr}$ .

6  $diM/dt$  - Maximum Rate of Current Change During the Trailing Portion of  $t_{rr}$ .

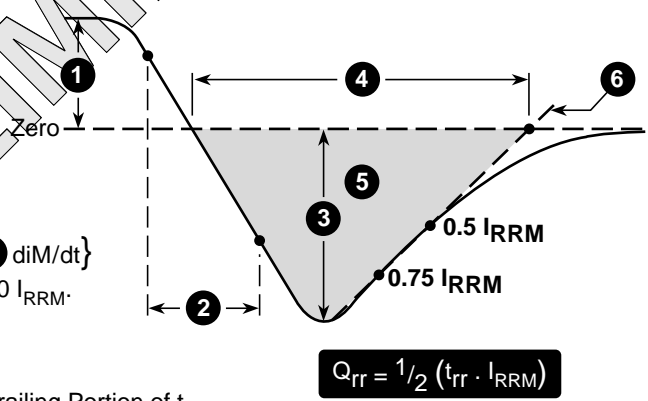
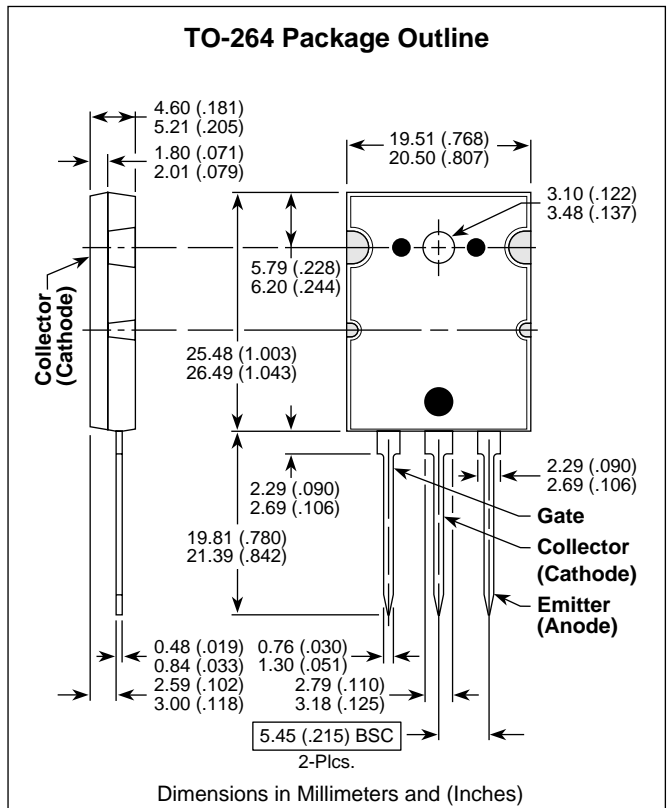
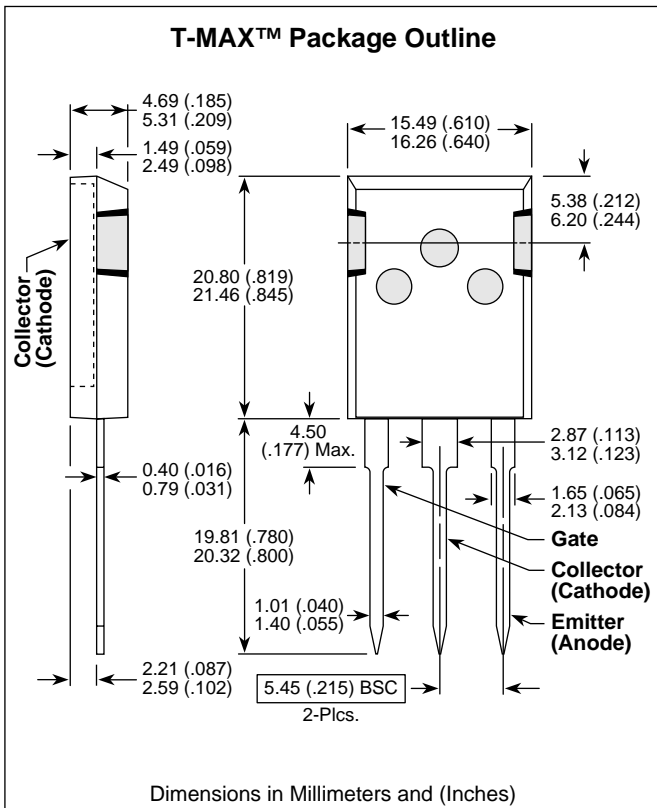

Figure 8, Diode Reverse Recovery Waveform and Definitions





LittleDiode supplies new, hard to find or obsolete electronic components and semiconductors all over the world.

With over two million different components listed you are sure to find the part you need.

Feel free to visit us today at our online store:

[LittleDiode.com](http://LittleDiode.com)

Looking forward to providing you with the best possible service.