

CR20EY

MEDIUM POWER, INVERTER USE
NON-INSULATED TYPE, GLASS PASSIVATION TYPE

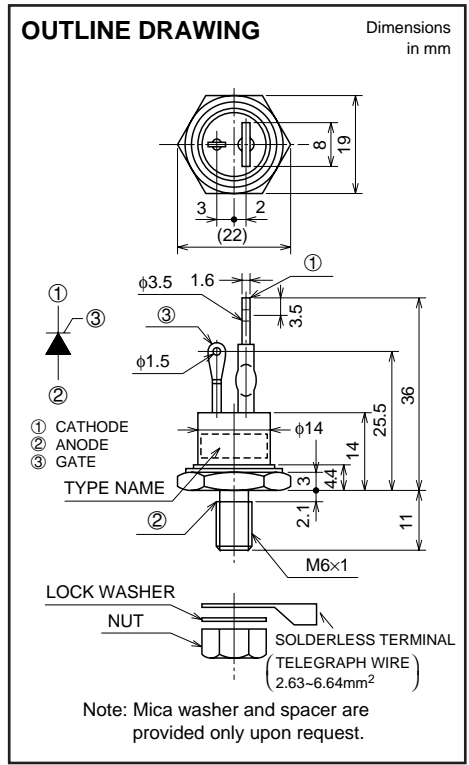

APPLICATION

Inverter, DC choppers, pulse generator

MAXIMUM RATINGS

Symbol	Parameter	Voltage class			Unit
		8	12	16	
VRRM	Repetitive peak reverse voltage	400	600	800	V
VRSM	Non-repetitive peak reverse voltage	480	720	850	V
VDRM	Repetitive peak off-state voltage	400	600	800	V
VDSM	Non-repetitive peak off-state voltage	480	720	800	V

Symbol	Parameter	Conditions	Ratings	Unit
I_T (RMS)	RMS on-state current		31.5	A
I_T (AV)	Average on-state current	Commercial frequency, sine half wave, 180° conduction, $T_c=74^\circ\text{C}$	20	A
I_{TSM}	Surge on-state current	60Hz sine half wave 1 full cycle, peak value, non-repetitive	300	A
I^2t	I^2t for fusing	Value corresponding to 1 cycle of half wave 60Hz, surge on-state current	380	A ² s
di/dt	Critical rate of rise of on-state current	$V_D=1/2V_{DRM}$, $I_{TM}=60\text{A}$, $I_G=0.1\text{A}$, $T_j=25^\circ\text{C}$, $f=60\text{Hz}$	100	A/ μs
PGM	Peak gate power dissipation		5.0	W
PG (AV)	Average gate power dissipation		0.5	W
VFGM	Peak gate forward voltage		10	V
VRGM	Peak gate reverse voltage		5	V
IFGM	Peak gate forward current		2	A
T_j	Junction temperature		-30 ~ +125	°C
T_{stg}	Storage temperature		-30 ~ +125	°C
—	Mounting torque		30	kg-cm
			2.94	N-m
—	Weight	Typical value	20	g

CR20EY

MEDIUM POWER, INVERTER USE
NON-INSULATED TYPE, GLASS PASSIVATION TYPE

ELECTRICAL CHARACTERISTICS

Symbol	Parameter	Test conditions	Limits			Unit
			Min.	Typ.	Max.	
I _{RRM}	Repetitive peak reverse current	T _j =125°C, V _{RRM} applied	—	—	6.0	mA
I _{DRM}	Repetitive peak off-state current	T _j =125°C, V _{DRM} applied	—	—	6.0	mA
V _{TM}	On-state voltage	T _c =25°C, I _{TM} =60A, Instantaneous value	—	—	2.5	V
dv/dt	Critical rate of rise of off-state voltage	T _j =125°C, V _D =2/3V _{DRM}	100	—	—	V/μs
V _{GT}	Gate trigger voltage	T _j =25°C, V _D =6V, I _T =0.5A	—	—	3.0	V
V _{GD}	Gate non-trigger voltage	T _j =125°C, V _D =1/2V _{DRM}	0.25	—	—	V
I _{GT}	Gate trigger current	T _j =25°C, V _D =6V, I _T =0.5A	—	—	50	mA
t _{gt}	Turn-on time	T _j =25°C, V _D =100V, I _T =15A, I _G =0.1A	—	—	10	μs
t _q	Turn-off time	I _T =20A, V _R =50V, V _D =1/2V _{DRM} , T _j =125°C, dv/dt=20V/μs	—	—	15	μs
R _{th(j-c)}	Thermal resistance	Junction to case	—	—	1.0	°C/W
R _{th(c-f)}	Contact thermal resistance	Case to fin, greased	—	—	0.40	°C/W

PERFORMANCE CURVES

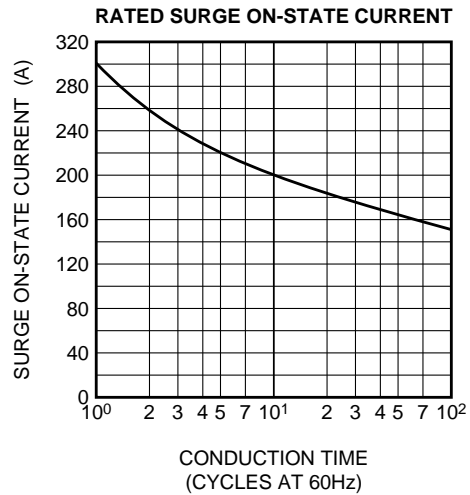
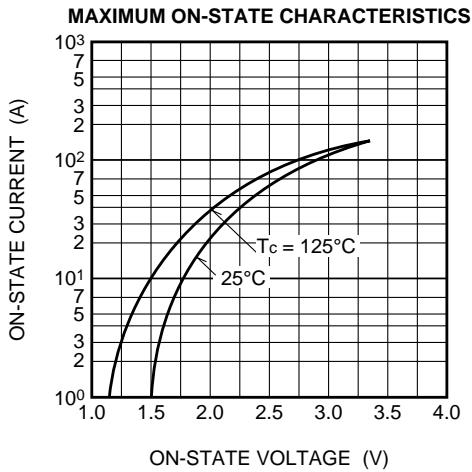

CR20EY

MEDIUM POWER, INVERTER USE
NON-INSULATED TYPE, GLASS PASSIVATION TYPE

GATE CHARACTERISTICS

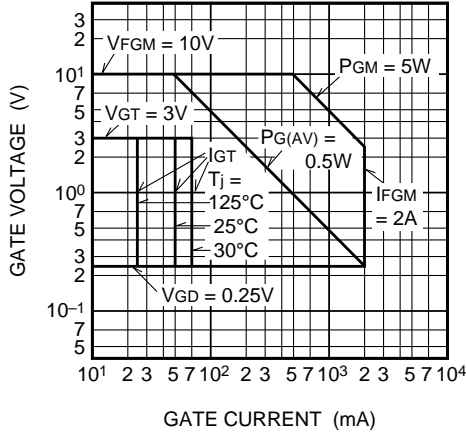

MAXIMUM TRANSIENT THERMAL IMPEDANCE CHARACTERISTICS (JUNCTION TO CASE)

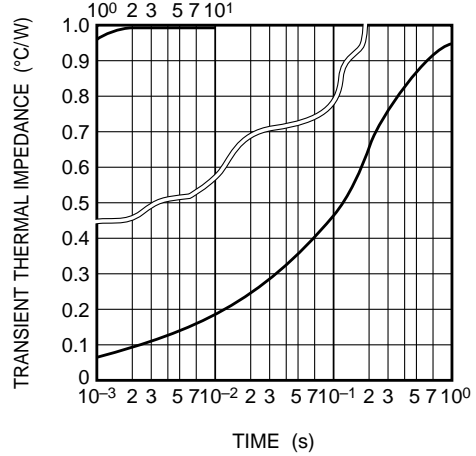

MAXIMUM AVERAGE POWER DISSIPATION (SINGLE-PHASE HALF WAVE)

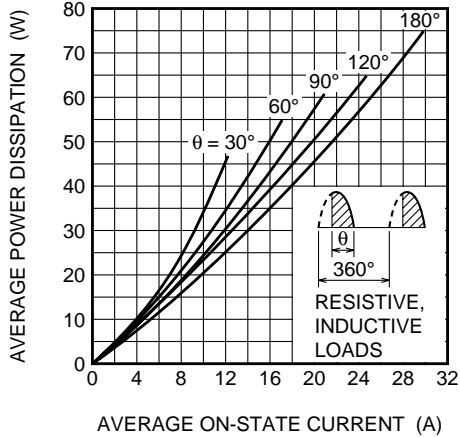

ALLOWABLE CASE TEMPERATURE VS. AVERAGE ON-STATE CURRENT (SINGLE-PHASE HALF WAVE)

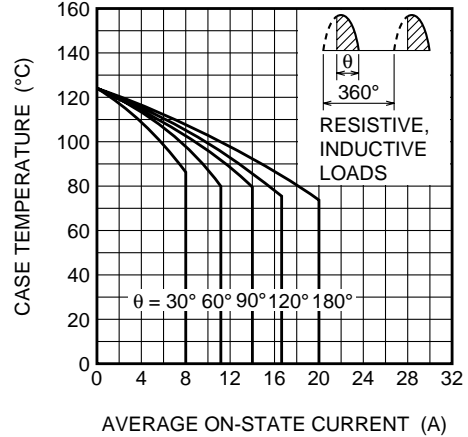

ALLOWABLE AMBIENT TEMPERATURE VS. AVERAGE ON-STATE CURRENT (SINGLE-PHASE HALF WAVE)

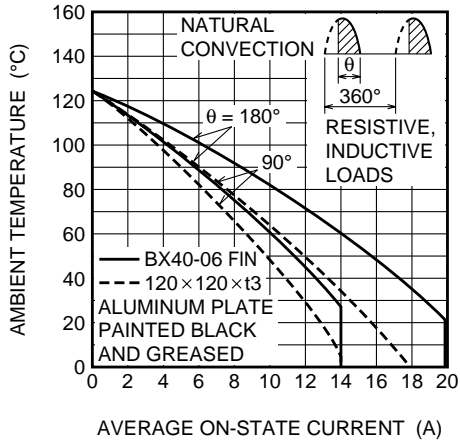

MAXIMUM AVERAGE POWER DISSIPATION (SINGLE-PHASE FULL WAVE)

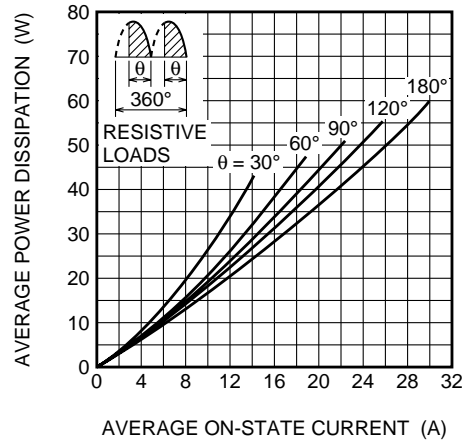

CR20EY

MEDIUM POWER, INVERTER USE
NON-INSULATED TYPE, GLASS PASSIVATION TYPE

ALLOWABLE CASE TEMPERATURE VS. AVERAGE ON-STATE CURRENT (SINGLE-PHASE FULL WAVE)

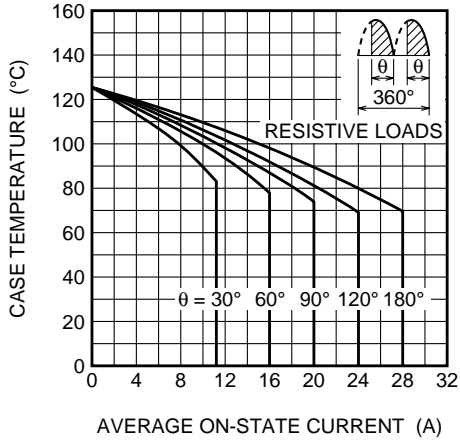

ALLOWABLE AMBIENT TEMPERATURE VS. AVERAGE ON-STATE CURRENT (SINGLE-PHASE FULL WAVE)

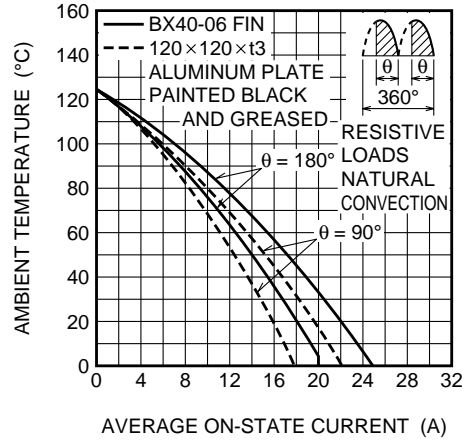

MAXIMUM AVERAGE POWER DISSIPATION (RECTANGULAR WAVE)

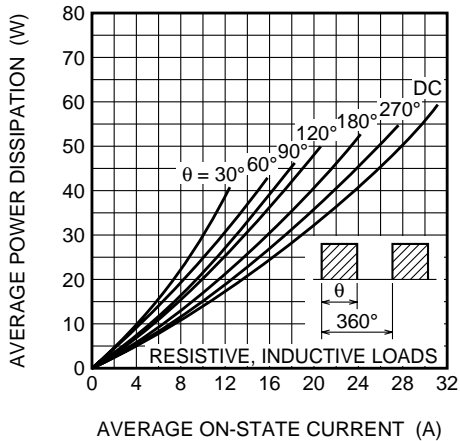

ALLOWABLE CASE TEMPERATURE VS. AVERAGE ON-STATE CURRENT (RECTANGULAR WAVE)

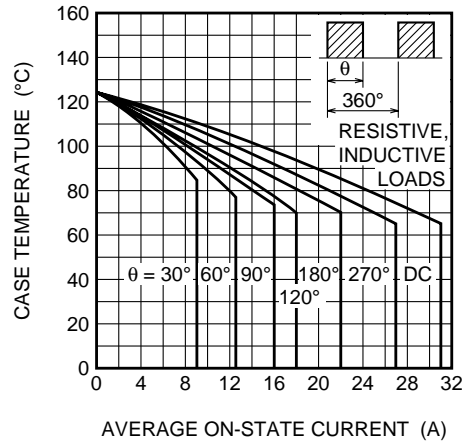

ALLOWABLE AMBIENT TEMPERATURE VS. AVERAGE ON-STATE CURRENT (RECTANGULAR WAVE)

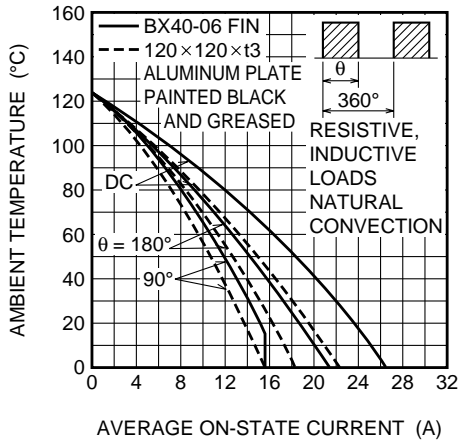

TURN-OFF TIME VS. JUNCTION TEMPERATURE

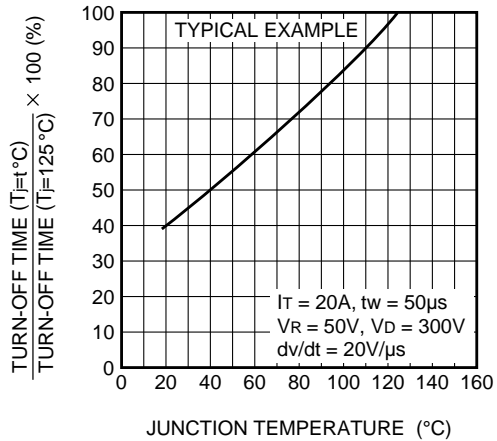

CR20EY

MEDIUM POWER, INVERTER USE
NON-INSULATED TYPE, GLASS PASSIVATION TYPE

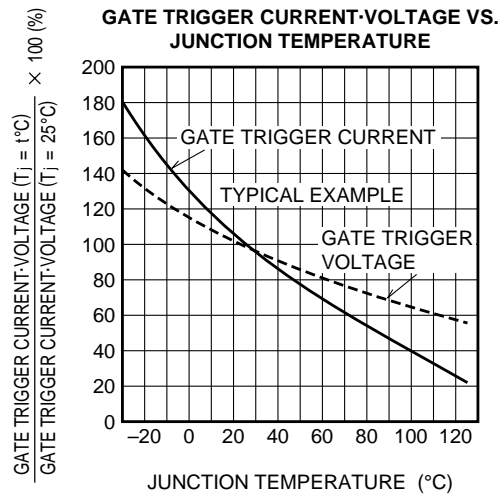
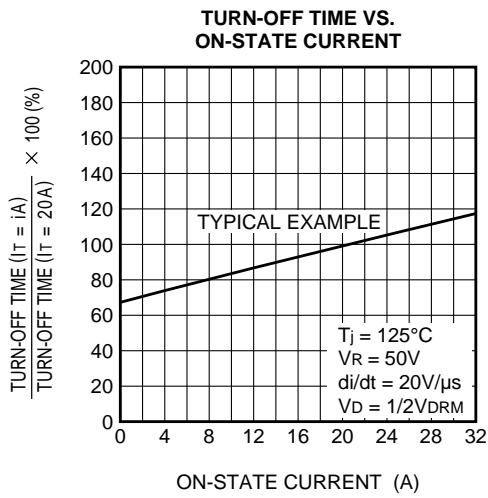



LittleDiode supplies new, hard to find or obsolete electronic components and semiconductors all over the world.

With over two million different components listed you are sure to find the part you need.

Feel free to visit us today at our online store:

LittleDiode.com

Looking forward to providing you with the best possible service.