



2.5V or 3.3V, 125-MHz, 14 Output Zero Delay Buffer

Features

- Output frequency range: 8.3 MHz to 125 MHz
- Input frequency range: 4.2 MHz to 62.5 MHz
- 2.5V or 3.3V operation
- Split 2.5V/3.3V outputs
- 14 Clock outputs: Drive up to 28 clock lines
- 1 Feedback clock output
- 2 LVCMOS reference clock inputs
- 150 ps max output-output skew
- PLL bypass mode
- Spread Aware™
- Output enable/disable
- Pin compatible with MPC9774
- Industrial temperature range: -40°C to +85°C
- 52-Pin 1.0-mm TQFP package

The CY29774 features two reference clock inputs and provides 14 outputs partitioned in 3 banks of 5, 5, and 4 outputs. Bank A and Bank B divide the VCO output by 4 or 8 while Bank C divides by 8 or 12 per SEL(A:C) settings, see *Functional Table*. These dividers allow output to input ratios of 6:1, 4:1, 3:1, 2:1, 3:2, 4:3, 1:1, and 2:3. Each LVCMOS compatible output can drive 50Ω series or parallel terminated transmission lines. For series terminated transmission lines, each output can drive one or two traces giving the device an effective fanout of 1:28.

The PLL is ensured stable given that the VCO is configured to run between 200 MHz to 500 MHz. This allows a wide range of output frequencies from 8.3 MHz to 125 MHz. For normal operation, the external feedback input, FB\_IN, is connected to the feedback output, FB\_OUT. The internal VCO is running at multiples of the input reference clock set by the feedback divider, see *Frequency Table*.

When PLL\_EN is LOW, PLL is bypassed and the reference clock directly feeds the output dividers. This mode is fully static and the minimum input clock frequency specification does not apply.

Description

The CY29774 is a low-voltage high-performance 125-MHz PLL-based zero delay buffer designed for high-speed clock distribution applications.

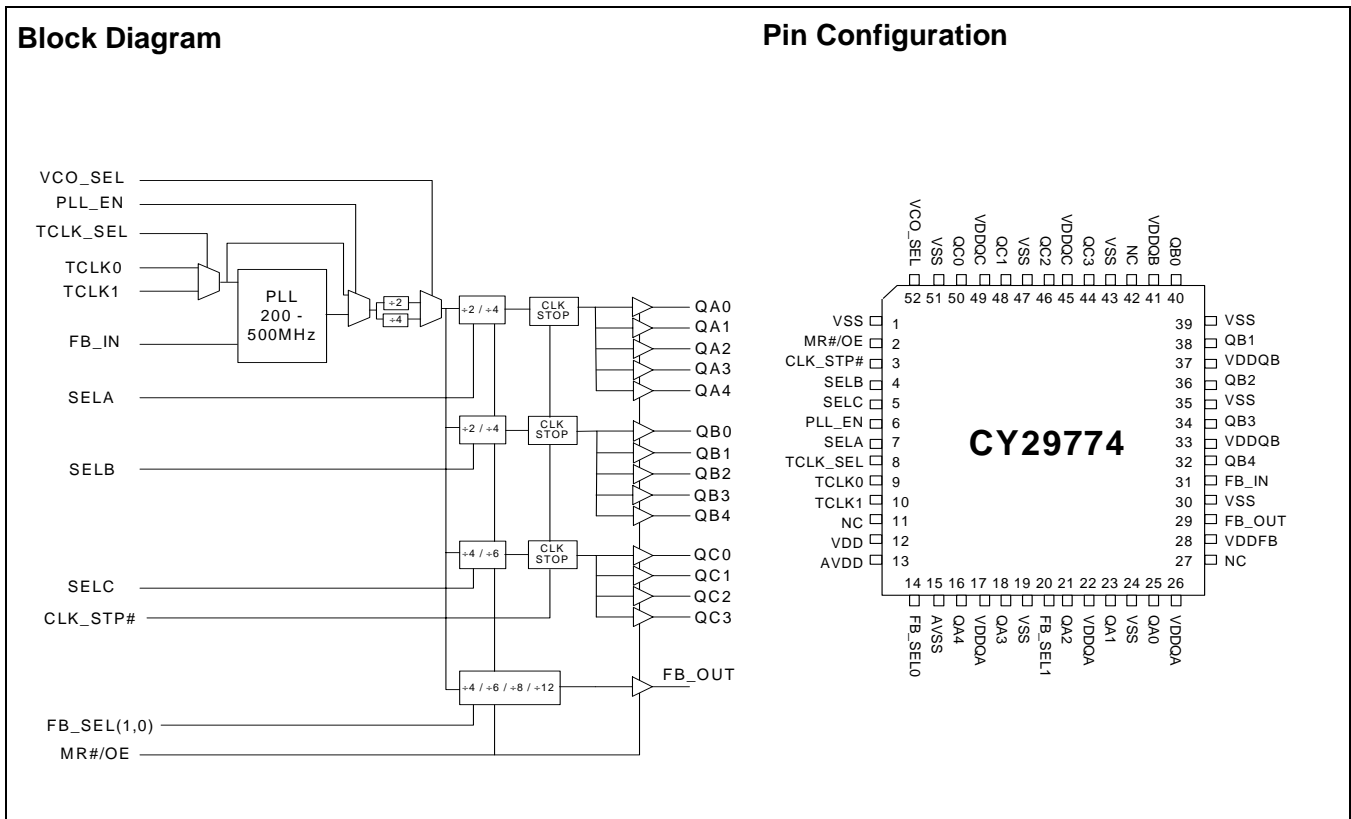

**Pin Description<sup>[1]</sup>**

Pin	Name	I/O	Type	Description
9	TCLK0	I, PD	LVC MOS	LVC MOS/LVTTL reference clock input
10	TCLK1	I, PU	LVC MOS	LVC MOS/LVTTL reference clock input
16, 18, 21, 23, 25	QA(4:0)	O	LVC MOS	Clock output bank A
32, 34, 36, 38, 40	QB(4:0)	O	LVC MOS	Clock output bank B
44, 46, 48, 50	QC(3:0)	O	LVC MOS	Clock output bank C
29	FB_OUT	O	LVC MOS	<b>Feedback clock output.</b> Connect to FB_IN for normal operation.
31	FB_IN	I, PU	LVC MOS	<b>Feedback clock input.</b> Connect to FB_OUT for normal operation. This input should be at the same voltage rail as input reference clock. See <i>Table 1</i> .
2	MR#/OE	I, PU	LVC MOS	<b>Output enable/disable input.</b> See <i>Table 2</i> .
3	CLK_STP#	I, PU	LVC MOS	<b>Clock stop enable/disable input.</b> See <i>Table 2</i> .
6	PLL_EN	I, PU	LVC MOS	<b>PLL enable/disable input.</b> See <i>Table 2</i> .
8	TCLK_SEL	I, PD	LVC MOS	<b>Reference select input.</b> See <i>Table 2</i> .
52	VCO_SEL	I, PD	LVC MOS	<b>VCO divider select input.</b> See <i>Table 2</i> .
7, 4, 5	SEL(A:C)	I, PD	LVC MOS	<b>Frequency select input, Bank (A:C).</b> See <i>Table 3</i> .
20, 14	FB_SEL(1,0)	I, PD	LVC MOS	<b>Feedback dividers select input.</b> See <i>Table 4</i> .
17, 22, 26	VDDQA	Supply	VDD	2.5V or 3.3V Power supply for bank A output clocks <sup>[2,3]</sup>
33, 37, 41	VDDQB	Supply	VDD	2.5V or 3.3V Power supply for bank B output clocks <sup>[2,3]</sup>
45, 49	VDDQC	Supply	VDD	2.5V or 3.3V Power supply for bank C output clocks <sup>[2,3]</sup>
28	VDDFB	Supply	VDD	2.5V or 3.3V Power supply for feedback output clock <sup>[2,3]</sup>
13	AVDD	Supply	VDD	2.5V or 3.3V Power supply for PLL <sup>[2,3]</sup>
12	VDD	Supply	VDD	2.5V or 3.3V Power supply for core and inputs <sup>[2,3]</sup>
15	AVSS	Supply	Ground	Analog Ground
1, 19, 24, 30, 35, 39, 43, 47, 51	VSS	Supply	Ground	Common Ground
11, 27, 42	NC			No Connection

**Notes:**

1. PU = Internal pull up, PD = Internal pull down
2. A 0.1- $\mu$ F bypass capacitor should be placed as close as possible to each positive power pin (<0.2"). If these bypass capacitors are not close to the pins their high frequency filtering characteristics will be cancelled by the lead inductance of the traces.
3. AVDD and VDD pins must be connected to a power supply level that is at least equal or higher than that of VDDQA, VDDQB, VDDQC, and VDDFB power supply pins.

**Table 1. Frequency Table**

Feedback Output Divider	VCO	Input Frequency Range (AVDD = 3.3V)	Input Frequency Range (AVDD = 2.5V)
÷8	Input Clock * 8	25 MHz to 62.5 MHz	25 MHz to 50 MHz
÷12	Input Clock * 12	16.6 MHz to 41.6 MHz	16.6 MHz to 33.3 MHz
÷16	Input Clock * 16	12.5 MHz to 31.25 MHz	12.5 MHz to 25 MHz
÷24	Input Clock * 24	8.3 MHz to 20.8 MHz	8.3 MHz to 16.6 MHz
÷32	Input Clock * 32	6.25 MHz to 15.625 MHz	6.25 MHz to 12.5 MHz
÷48	Input Clock * 48	4.2 MHz to 10.4 MHz	4.2 MHz to 8.3 MHz

**Table 2. Function Table (configuration controls)**

Control	Default	0	1
TCLK_SEL	0	TCLK0	TCLK1
VCO_SEL	0	VCO÷2 (high input frequency range)	VCO÷4 (low input frequency range)
PLL_EN	1	Bypass mode, PLL disabled. The input clock connects to the output dividers	PLL enabled. The VCO output connects to the output dividers
MR#/OE	1	Outputs disabled (three-state) and reset of the device. During reset/output disable the PLL feedback loop is open and the VCO running at its minimum frequency. The device is reset by the internal power-on reset (POR) circuitry during power-up.	Outputs enabled
CLK_STP#	1	QA, QB, and QC outputs disabled in LOW state. FB_OUT is not affected by CLK_STP#.	Outputs enabled

**Table 3. Function Table (Bank A, B and C)**

VCO_SEL	SELA	QA(4:0)	SELB	QB(4:0)	SELC	QC(3:0)
0	0	÷4	0	÷4	0	÷8
0	1	÷8	1	÷8	1	÷12
1	0	÷8	0	÷8	0	÷16
1	1	÷16	1	÷16	1	÷24

**Table 4. Function Table (FB\_OUT)**

VCO_SEL	FB_SEL1	FB_SEL0	FB_OUT
0	0	0	÷8
0	0	1	÷16
0	1	0	÷12
0	1	1	÷24
1	0	0	÷16
1	0	1	÷32
1	1	0	÷24
1	1	1	÷48

**Absolute Maximum Conditions**

Parameter	Description	Condition	Min.	Max.	Unit
V <sub>DD</sub>	DC Supply Voltage		-0.3	5.5	V
V <sub>DD</sub>	DC Operating Voltage	Functional	2.375	3.465	V
V <sub>IN</sub>	DC Input Voltage	Relative to V <sub>SS</sub>	-0.3	V <sub>DD</sub> + 0.3	V
V <sub>OUT</sub>	DC Output Voltage	Relative to V <sub>SS</sub>	-0.3	V <sub>DD</sub> + 0.3	V
V <sub>TT</sub>	Output termination Voltage		-	V <sub>DD</sub> ÷ 2	V
LU	Latch Up Immunity	Functional	200	-	mA
R <sub>PS</sub>	Power Supply Ripple	Ripple Frequency < 100 kHz	-	150	mVp-p
T <sub>S</sub>	Temperature, Storage	Non Functional	-65	+150	°C
T <sub>A</sub>	Temperature, Operating Ambient	Functional	-40	+85	°C
T <sub>J</sub>	Temperature, Junction	Functional	-	150	°C
∅ <sub>JC</sub>	Dissipation, Junction to Case	Functional	-	23	°C/W
∅ <sub>JA</sub>	Dissipation, Junction to Ambient	Functional	-	55	°C/W
ESD <sub>H</sub>	ESD Protection (Human Body Model)		2000	-	Volts
FIT	Failure in Time	Manufacturing test		10	ppm

**DC Electrical Specifications (V<sub>DD</sub>= 2.5V ± 5%, T<sub>A</sub> = -40°C to +85°C)**

Parameter	Description	Condition	Min.	Typ.	Max.	Unit
V <sub>IL</sub>	Input Voltage, Low	LVC MOS	-	-	0.7	V
V <sub>IH</sub>	Input Voltage, High	LVC MOS	1.7	-	V <sub>DD</sub> +0.3	V
V <sub>OL</sub>	Output Voltage, Low <sup>[4]</sup>	I <sub>OL</sub> = 15 mA	-	-	0.6	V
V <sub>OH</sub>	Output Voltage, High <sup>[4]</sup>	I <sub>OH</sub> = -15 mA	1.8	-	-	V
I <sub>IL</sub>	Input Current, Low <sup>[5]</sup>	V <sub>IL</sub> = V <sub>SS</sub>	-	-	-100	μA
I <sub>IH</sub>	Input Current, High <sup>[5]</sup>	V <sub>IL</sub> = V <sub>DD</sub>	-	-	-	μA
I <sub>DDA</sub>	PLL Supply Current	A <sub>VDD</sub> only	-	5	10	mA
I <sub>DDQ</sub>	Quiescent Supply Current	All V <sub>DD</sub> pins except A <sub>VDD</sub>	-	-	1	mA
I <sub>DD</sub>	Dynamic Supply Current	Outputs loaded @ 100 MHz	-	135	-	mA
C <sub>IN</sub>	Input Pin Capacitance		-	4	-	pF
Z <sub>OUT</sub>	Output Impedance		14	18	22	Ω

**DC Electrical Specifications (V<sub>DD</sub>= 3.3V ± 5%, T<sub>A</sub> = -40°C to +85°C)**

Parameter	Description	Condition	Min.	Typ.	Max.	Unit
V <sub>IL</sub>	Input Voltage, Low	LVC MOS	-	-	0.8	V
V <sub>IH</sub>	Input Voltage, High	LVC MOS	2.0	-	V <sub>DD</sub> +0.3	V
V <sub>OL</sub>	Output Voltage, Low <sup>[4]</sup>	I <sub>OL</sub> = 24 mA	-	-	0.55	V
		I <sub>OL</sub> = 12 mA	-	-	0.30	
V <sub>OH</sub>	Output Voltage, High <sup>[4]</sup>	I <sub>OH</sub> = -24 mA	2.4	-	-	V
I <sub>IL</sub>	Input Current, Low <sup>[5]</sup>	V <sub>IL</sub> = V <sub>SS</sub>	-	-	-100	μA
I <sub>IH</sub>	Input Current, High <sup>[5]</sup>	V <sub>IL</sub> = V <sub>DD</sub>	-	-	100	μA

**Notes:**

- Driving one 50Ω parallel terminated transmission line to a termination voltage of V<sub>TT</sub>. Alternatively, each output drives up to two 50Ω series terminated transmission lines.
- Inputs have pull-up or pull-down resistors that affect the input current.

**DC Electrical Specifications** ( $V_{DD} = 3.3V \pm 5\%$ ,  $T_A = -40^\circ C$  to  $+85^\circ C$ ) (continued)

Parameter	Description	Condition	Min.	Typ.	Max.	Unit
$I_{DDA}$	PLL Supply Current	$A_{VDD}$ only	–	5	10	mA
$I_{DDQ}$	Quiescent Supply Current	All $V_{DD}$ pins except $A_{VDD}$	–	–	1	mA
$I_{DD}$	Dynamic Supply Current	Outputs loaded @ 100 MHz	–	225	–	mA
$C_{IN}$	Input Pin Capacitance		–	4	–	pF
$Z_{OUT}$	Output Impedance		12	15	18	$\Omega$

**AC Electrical Specifications**<sup>[6]</sup> ( $V_{DD} = 2.5V \pm 5\%$ ,  $T_A = -40^\circ C$  to  $+85^\circ C$ )

Parameter	Description	Condition	Min.	Typ.	Max.	Unit
$f_{VCO}$	VCO Frequency		200	–	400	MHz
$f_{in}$	Input Frequency	+8 Feedback	25	–	50	MHz
		+12 Feedback	16.6	–	33.3	
		+16 Feedback	12.5	–	25	
		+24 Feedback	8.3	–	16.6	
		+32 Feedback	6.3	–	12.5	
		+48 Feedback	4.2	–	8.3	
		Bypass mode (PLL_EN = 0)	0	–	200	
$f_{refDC}$	Input Duty Cycle		25	–	75	%
$t_r, t_f$	TCLK Input Rise/Fall Time	0.7V to 1.7V	–	–	1.0	ns
$f_{MAX}$	Maximum Output Frequency	+4 Output	50	–	100	MHz
		+8 Output	25	–	50	
		+12 Output	16.6	–	33.3	
		+16 Output	12.5	–	25	
		+24 Output	8.3	–	16.6	
DC	Output Duty Cycle		45	–	55	%
$t_r, t_f$	Output Rise/Fall times	0.7V to 1.8V	0.1	–	1.0	ns
$t_{(\phi)}$	Propagation Delay (static phase offset)	TCLK to FB_IN, does not include jitter	–100	–	100	ps
$t_{sk(O)}$	Output-to-Output Skew	Skew within Bank	–	–	150	ps
tsk(B)	Bank-to-Bank Skew	Banks at same frequency	–	–	150	ps
		Banks at different frequency	–	–	225	
$t_{PLZ, HZ}$	Output Disable Time		–	–	10	ns
$t_{PZL, ZH}$	Output Enable Time		–	–	10	ns
BW	PLL Closed Loop Bandwidth (–3 dB)		–	0.5 - 1.0	–	MHz
$t_{JIT(CC)}$	Cycle-to-Cycle Jitter	Same frequency	–	–	150	ps
		Multiple frequencies	–	–	300	
$t_{JIT(PER)}$	Period Jitter		–	–	100	ps
$t_{JIT(\phi)}$	I/O Phase Jitter		–	–	150	ps
$t_{LOCK}$	Maximum PLL Lock Time		–	–	1	ms

**Note:**

6. AC characteristics apply for parallel output termination of 50 $\Omega$  to  $V_{TT}$ . Parameters are guaranteed by characterization and are not 100% tested.

**AC Electrical Specifications<sup>[6]</sup>** ( $V_{DD} = 3.3V \pm 5\%$ ,  $T_A = -40^{\circ}C$  to  $+85^{\circ}C$ )

Parameter	Description	Condition	Min.	Typ.	Max.	Unit
$f_{VCO}$	VCO Frequency		200	–	500	MHz
$f_{in}$	Input Frequency	÷8 Feedback	25	–	62.5	MHz
		÷12 Feedback	16.6	–	41.6	
		÷16 Feedback	12.5	–	31.25	
		÷24 Feedback	8.3	–	20.8	
		÷32 Feedback	6.25	–	15.625	
		÷48 Feedback	4.2	–	10.4	
		Bypass mode (PLL_EN = 0)	0	–	200	
$f_{refDC}$	Input Duty Cycle		25	–	75	%
$t_r, t_f$	TCLK Input Rise/FallTime	0.8V to 2.0V		–	1.0	ns
$f_{MAX}$	Maximum Output Frequency	÷4 Output	50	–	125	MHz
		÷8 Output	25	–	62.5	
		÷12 Output	16.6	–	41.6	
		÷16 Output	12.5	–	31.25	
		÷24 Output	8.3	–	20.8	
DC	Output Duty Cycle		45	–	55	%
$t_r, t_f$	Output Rise/Fall times	0.8V to 2.4V	0.1	–	1.0	ns
$t_{(\phi)}$	Propagation Delay (static phase offset)	TCLK to FB_IN, same $V_{DD}$ , does not include jitter	–100	–	100	ps
$t_{sk(O)}$	Output-to-Output Skew	Skew within Bank	–	–	150	ps
$t_{sk(B)}$	Bank-to-Bank Skew	Banks at same voltage, same frequency	–	–	150	ps
		Banks at same voltage, different frequency	–	–	225	
		Banks at different voltage	–	–	250	
$t_{PLZ, HZ}$	Output Disable Time		–	–	10	ns
$t_{PZL, ZH}$	Output Enable Time		–	–	10	ns
BW	PLL Closed Loop Bandwidth (–3dB)		–	0.5 - 1.0	–	MHz
$t_{JIT(CC)}$	Cycle-to-Cycle Jitter	Same frequency	–	–	150	ps
		Multiple frequencies	–	–	300	
$t_{JIT(PER)}$	Period Jitter		–	–	100	ps
$t_{JIT(\phi)}$	I/O Phase Jitter	I/O at same $V_{DD}$	–	–	150	ps
$t_{LOCK}$	Maximum PLL Lock Time		–	–	1	ms

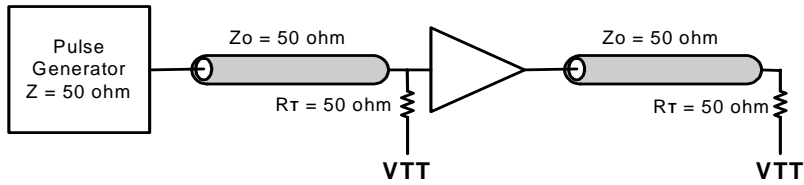

Figure 1. AC Test Reference for  $V_{DD} = 3.3V / 2.5V$

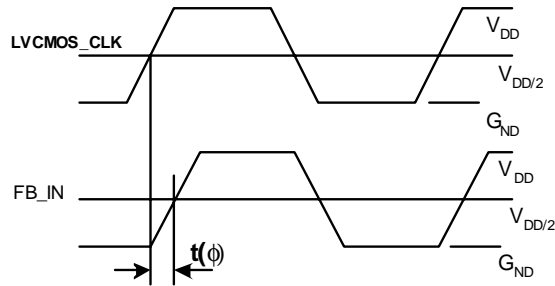

Figure 2. Propagation Delay  $t(\phi)$ , Static Phase Offset

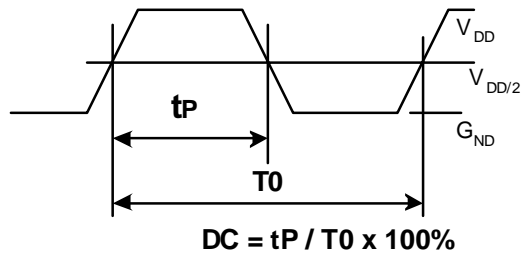

Figure 3. Output Duty Cycle (DC)

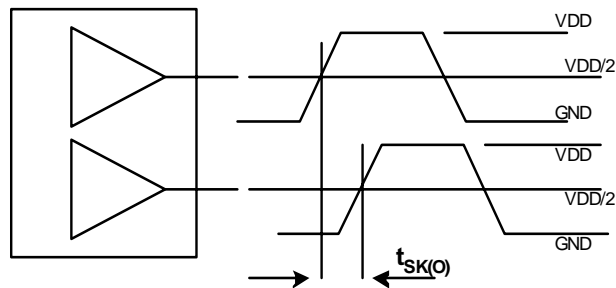

Figure 4. Output-to-Output Skew,  $t_{sk(O)}$

**Ordering Information**

Part Number	Package Type	Product Flow
CY29774AI	52-pin TQFP	Industrial, -40°C to +85°C
CY29774AIT	52-pin TQFP -Tape and Reel	Industrial, -40°C to 85°C

**Package Drawing and Dimension**

**52-Lead Thin Plastic Quad Flat Pack (10 x 10 x 1.0 mm) A52B**

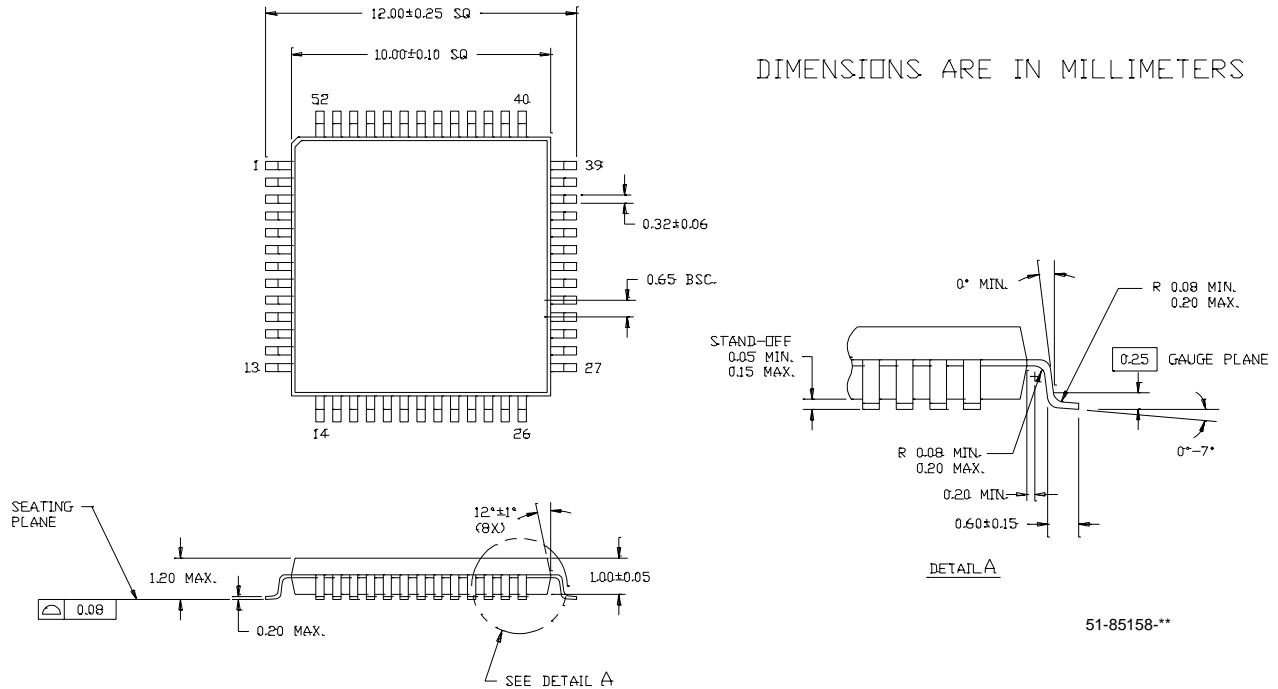

Spread Aware is a trademark of Cypress Semiconductor Corporation. All product and company names mentioned in this document are the trademarks of their respective holders.

**Document History Page**

Document Title: CY29774 2.5V or 3.3V, 125-MHz, 14 Output Zero Delay Buffer Document #: 38-07479				
Rev.	ECN No.	Issue Date	Orig. of Change	Description of Change
**	125954	05/01/03	RGL	New Data Sheet



LittleDiode supplies new, hard to find or obsolete electronic components and semiconductors all over the world.

With over two million different components listed you are sure to find the part you need.

Feel free to visit us today at our online store:

[LittleDiode.com](http://LittleDiode.com)

Looking forward to providing you with the best possible service.