

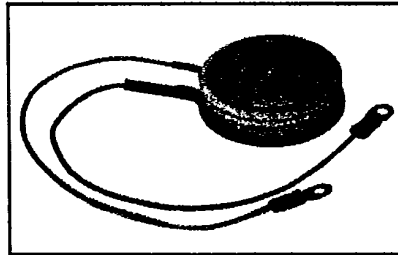

FT500DL

Powerex, Inc. Hillis Street, Youngwood, Pennsylvania 15697 (412) 925-7272
 Powerex Europe, S.A., 428 Ave. G. Durand, BP107, 72003 LeMans, France (43) 72.75.15

Phase Control SCR
500 Amperes Avg
200-1400 Volts

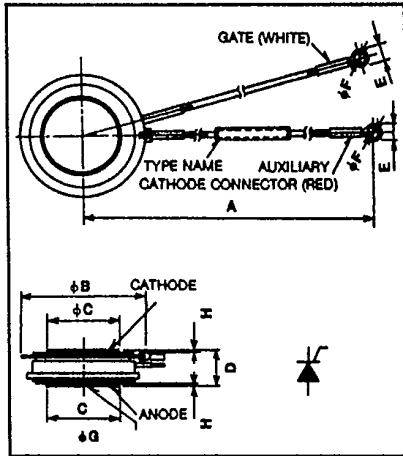

FT500DL
Phase Control SCR
 500 Amperes/200-1400 Volts

FT500DL
Outline Drawing

Dimensions	Inches	Metric
A	16.93 ± .40	430 ± 10
φB	2.362 Max	60 Max
φC	1.260	32
D	.57 ± .02	14.5 ± 0.5
E	.30	7.5
φF	.169	4.3
φG	.165	4.2
H	.015 Min	0.4 Min

Description

Powerex Silicon Controlled Rectifiers (SCR) are designed for phase control applications. These are all-diffused, Press-Pak (Pow-R-Disc) devices employing the field-proven amplifying (di/namic) gate.

Features:

- Low On-State Voltage
- High di/dt
- High dv/dt
- Hermetic Packaging
- Excellent Surge and I²t Ratings

Applications:

- Power Supplies
- Battery Chargers
- Motor Control
- Light Dimmers
- VAR Generators

Ordering Information

Example: Select the complete eight or nine digit part number you desire from the table - i.e. FT500DL-12 is a 600 Volt, 500 Ampere Phase Control SCR.

Type	Voltage*		Current I _T (avg)
	V _{ORM} V _{RRM}	Code	
FT500DL	200	-4	500
	300	-6	
	400	-8	
	500	-10	
	600	-12	
	800	-16	
	1000	-20	
	1200	-24	
	1400	-28	

*Voltage classes 12, 16, 24, and 28 are standard products.



T-25-20

Powerex, Inc., Hillis Street, Youngwood, Pennsylvania 15697 (412) 925-7272

Powerex Europe, S.A., 428 Ave. G. Durand, BP107, 72003 LeMans, France (43) 72.75.15

FT500DL**Phase Control SCR**

500 Amperes Avg/200-1400 Volts

Absolute Maximum Ratings

	Symbol	FT500DL	Units
RMS On-State Current	$I_{T(RMS)}$	790	Amperes
Average On-State Current	$I_{T(av)}$	500	Amperes
Peak One-Cycle Surge (Non Repetitive) On-State Current (60Hz)	I_{TSM}	10,000	Amperes
Peak One-Cycle Surge (Non-Repetitive) On-State Current (50Hz)	I_{TSM}	9100	Amperes
Critical Rate-of-Rise of On-State Current (Non-Repetitive)	di/dt	500	Amperes/ μ s
Critical Rate-of-Rise of On-State Current (Repetitive)	di/dt	200	Amperes/ μ s
I^2t (for Fusing), one cycle at 60Hz	I^2t	4.2×10^5	A ² sec
Peak Gate Power Dissipation	P_{GM}	10	Watts
Average Gate Power Dissipation	$P_{G(av)}$	3	Watts
Storage Temperature	T_{STG}	-40 to 150	°C
Operating Temperature	T_J	-40 to 125	°C
Mounting Force [ⓐ]		3000 to 4000	lb.
Mounting Force [ⓐ]		1350 to 1800	kg

[ⓐ] Consult recommended mounting procedures.



T-25-20

Powerex, Inc., Hillis Street, Youngwood, Pennsylvania 15697 (412) 925-7272

Powerex Europe, S.A., 428 Ave. G. Durand, BP107, 72003 LeMans, France (43) 72.75.15

FT500DL**Phase Control SCR**

500 Amperes Avg/200-1400 Volts

Electrical and Thermal Characteristics

Characteristics	Symbol	Test Conditions	FT500DL	Units
Voltage—Blocking State Maximums				
Forward Leakage, Peak	I_{DRM}	$T_J = 125^\circ\text{C}$, V_{DRM} applied	30	mA
Reverse Leakage, Peak	I_{RRM}	$T_J = 125^\circ\text{C}$, V_{RRM} applied	30	mA
Current—Conducting State Maximums				
Peak On-State Voltage	V_{TM}	$I_{TM} = 1500\text{A}$, $T_J = 125^\circ\text{C}$	1.75	Volts
Switching				
Min. Critical dv/dt exponential to V_{DRM}	dv/dt	$T_J = 125^\circ\text{C}$, $V_D = \frac{1}{2}V_{DRM}$	200	V/ μsec
Thermal				
Maximum Thermal Resistance, [Ⓞ] double sided cooling Junction to Sink	$R_{\theta JS}$.05	$^\circ\text{C}/\text{Watt}$
Gate—Maximum Parameters				
Gate Current to Trigger	I_{GT}	$V_D = 6\text{V}$, $R_L = 2\Omega$	250	mA
Gate Voltage to Trigger	V_{GT}	$T_J = 25^\circ\text{C}$, $V_D = 6\text{V}$, $R_L = 2\Omega$	2.5	Volts
Non-Triggering Gate Voltage	V_{GDM}	$T_J = 125^\circ\text{C}$, $V_D = \frac{1}{2}V_{DRM}$, rated	.20	Volts
Peak Forward Gate Current	I_{GTM}		4.0	Amperes
Peak Reverse Gate Voltage	V_{GRM}		5.0	Volts

[Ⓞ] Consult recommended mounting procedures.



T-25-20

Powerex, Inc., Hillis Street, Youngwood, Pennsylvania 15697 (412) 925-7272
 Powerex Europe, S.A., 428 Ave. G. Durand, BP107, 72003 LeMans, France (43) 72.75.15

FT500DL
 Phase Control SCR
 500 Amperes Avg/200-1400 Volts

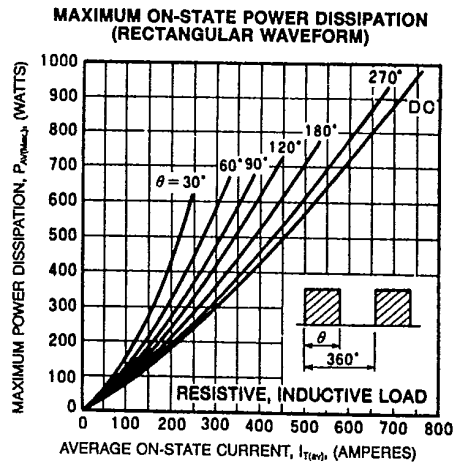
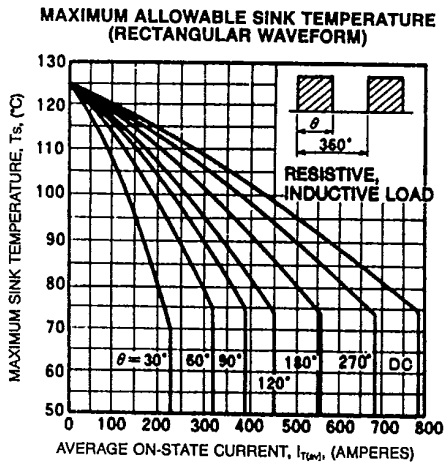
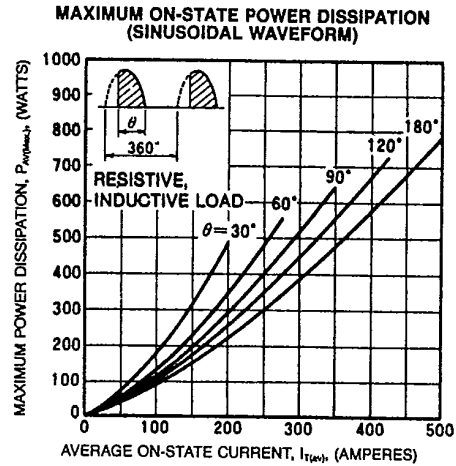
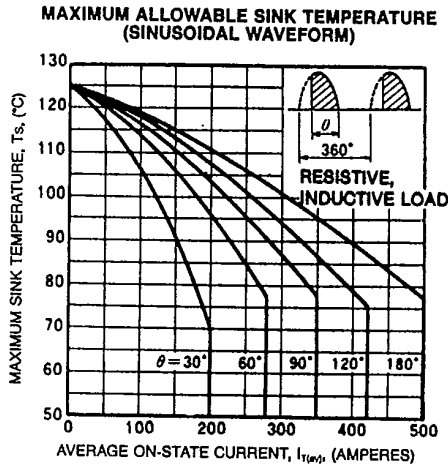
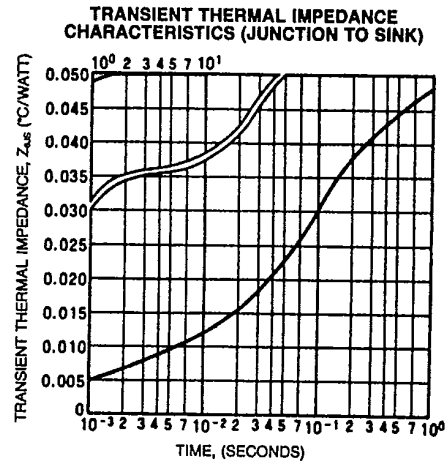
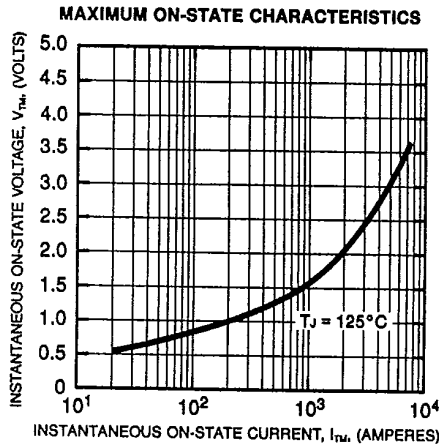



T-25-20

Powerex, Inc., Hillis Street, Youngwood, Pennsylvania 15697 (412) 925-7272
 Powerex Europe, S.A., 428 Ave. G. Durand, BP107, 72003 LeMans, France (43) 72.75.15

FT500DL
 Phase Control SCR
 500 Amperes Avg/200-1400 Volts

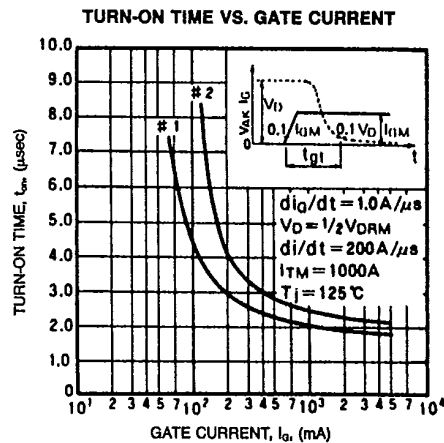
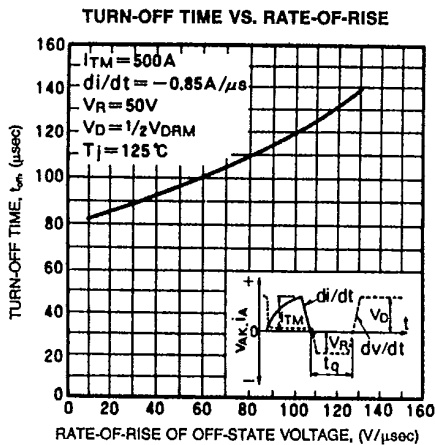
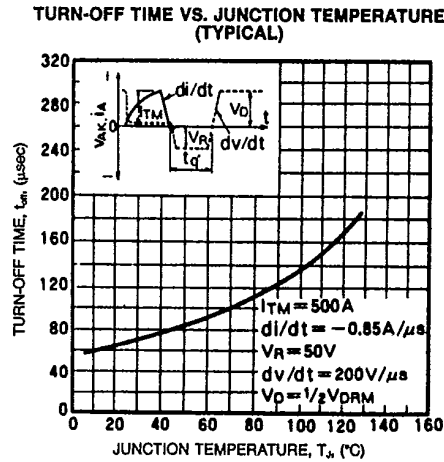
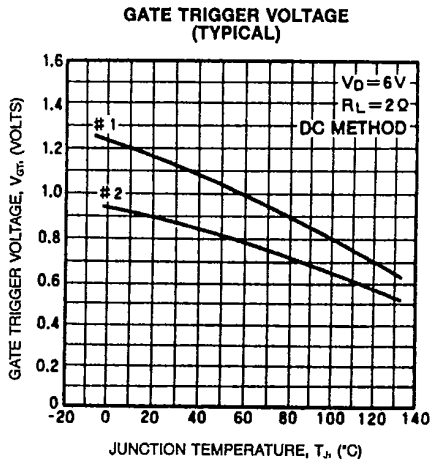
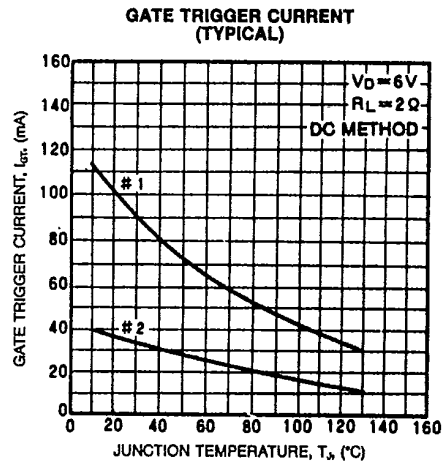
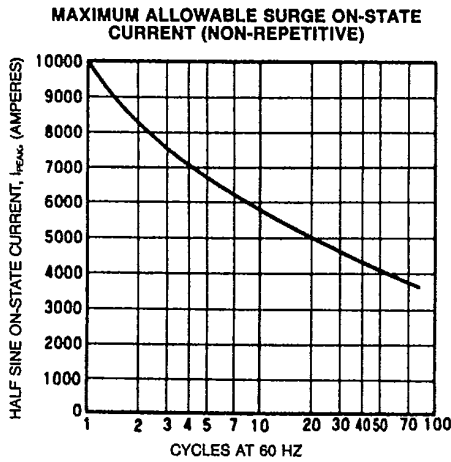



T-25-20

Powerex, Inc., Hillis Street, Youngwood, Pennsylvania 15697 (412) 925-7272
 Powerex Europe, S.A., 428 Ave. G. Durand, BP107, 72003 LeMans, France (43) 72.75.15

FT500DL
 Phase Control SCR
 500 Amperes Avg/200-1400 Volts

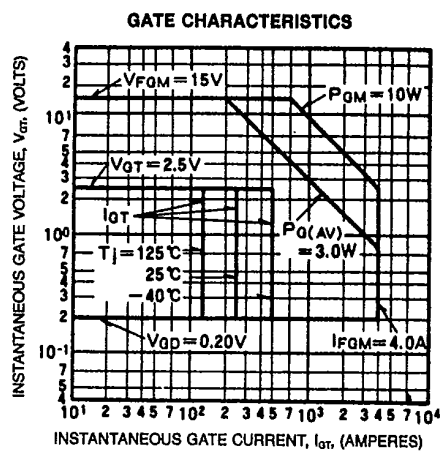
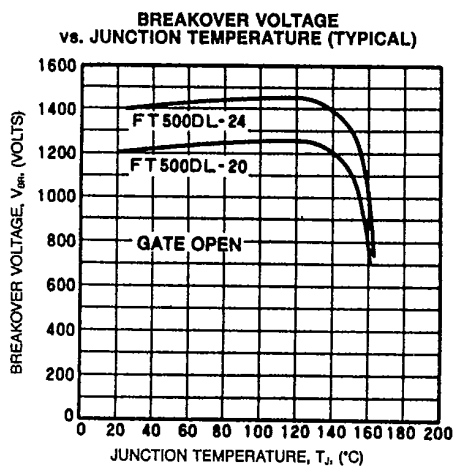



LittleDiode supplies new, hard to find or obsolete electronic components and semiconductors all over the world.

With over two million different components listed you are sure to find the part you need.

Feel free to visit us today at our online store:

LittleDiode.com

Looking forward to providing you with the best possible service.