

# IRGP30B120KD-E

## INSULATED GATE BIPOLAR TRANSISTOR WITH ULTRAFAST SOFT RECOVERY DIODE

## Motor Control Co-Pack IGBT

### Features

- Low  $V_{CE(on)}$  Non Punch Through (NPT) Technology
- Low Diode  $V_F$  (1.76V Typical @ 25A & 25°C)
- 10  $\mu$ s Short Circuit Capability
- Square RBSOA
- Ultrasoft Diode Recovery Characteristics
- Positive  $V_{CE(on)}$  Temperature Coefficient
- Extended Lead TO-247AD Package

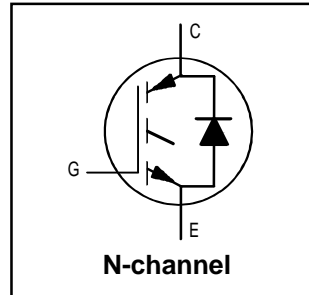

$V_{CES} = 1200V$
$V_{CE(on) \text{ typ.}} = 2.28V$
$V_{GE} = 15V, I_C = 25A, 25^\circ C$

### Benefits

- Benchmark Efficiency for Motor Control Applications
- Rugged Transient Performance
- Low EMI
- Significantly Less Snubber Required
- Excellent Current Sharing in Parallel Operation
- Longer leads for Easier Mounting

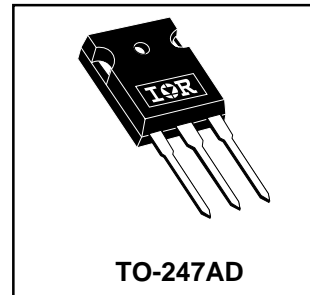

### Absolute Maximum Ratings

	Parameter	Max.	Units
$V_{CES}$	Collector-to-Emitter Breakdown Voltage	1200	V
$I_C @ T_C = 25^\circ C$	Continuous Collector Current (Fig.1)	60	A
$I_C @ T_C = 100^\circ C$	Continuous Collector Current (Fig.1)	30	
$I_{CM}$	Pulsed Collector Current (Fig.3, Fig. CT.5)	120	
$I_{LM}$	Clamped Inductive Load Current(Fig.4, Fig. CT.2)	120	
$I_F @ T_C = 100^\circ C$	Diode Continuous Forward Current	30	
$I_{FM}$	Diode Maximum Forward Current	120	
$V_{GE}$	Gate-to-Emitter Voltage	$\pm 20$	
$P_D @ T_C = 25^\circ C$	Maximum Power Dissipation (Fig.2)	300	W
$P_D @ T_C = 100^\circ C$	Maximum Power Dissipation (Fig.2)	120	
$T_J$	Operating Junction and Storage Temperature Range	-55 to + 150	°C
$T_{STG}$			
	Mounting Torque, 6-32 or M3 screw.	10 lbf•in (1.1N•m)	

### Thermal Resistance

	Parameter	Min.	Typ.	Max.	Units
$R_{\theta JC}$	Junction-to-Case - IGBT	—	—	0.42	°C/W
$R_{\theta JC}$	Junction-to-Case - Diode	—	—	0.83	
$R_{\theta CS}$	Case-to-Sink, flat, greased surface	—	0.24	—	
$R_{\theta JA}$	Junction-to-Ambient, typical socket mount	—	—	40	
$W_t$	Weight	—	6 (0.21)	—	g (oz)
$Z_{\theta JC}$	Transient Thermal Impedance Junction-to-Case (Fig.24)				

# IRGP30B120KD-E

## Electrical Characteristics @ T<sub>J</sub> = 25°C (unless otherwise specified)

	Parameter	Min.	Typ.	Max.	Units	Conditions	Fig.
V <sub>(BR)CES</sub>	Collector-to-Emitter Breakdown Voltage	1200			V	V <sub>GE</sub> = 0V, I <sub>C</sub> = 250 μA	
ΔV <sub>(BR)CES</sub> / ΔT <sub>J</sub>	Temperature Coeff. of Breakdown Voltage		+1.2		V/°C	V <sub>GE</sub> = 0V, I <sub>C</sub> = 1 mA ( 25 -125 °C )	
V <sub>CE(on)</sub>	Collector-to-Emitter Saturation Voltage		2.28	2.48	V	I <sub>C</sub> = 25A, V <sub>GE</sub> = 15V	5, 6
			2.46	2.66		I <sub>C</sub> = 30A, V <sub>GE</sub> = 15V	7, 9
			3.43	4.00		I <sub>C</sub> = 60A, V <sub>GE</sub> = 15V	10
			2.74	3.10		I <sub>C</sub> = 25A, V <sub>GE</sub> = 15V, T <sub>J</sub> = 125°C	11
			2.98	3.35		I <sub>C</sub> = 30A, V <sub>GE</sub> = 15V, T <sub>J</sub> = 125°C	
V <sub>GE(th)</sub>	Gate Threshold Voltage	4.0	5.0	6.0	V	V <sub>CE</sub> = V <sub>GE</sub> , I <sub>C</sub> = 250 μA	9,10,11,12
ΔV <sub>GE(th)</sub> / ΔT <sub>J</sub>	Temperature Coeff. of Threshold Voltage		- 1.2		mV/°C	V <sub>CE</sub> = V <sub>GE</sub> , I <sub>C</sub> = 1 mA ( 25 -125 °C )	
g <sub>fe</sub>	Forward Transconductance	14.8	16.9	19.0	S	V <sub>CE</sub> = 50V, I <sub>C</sub> = 25A, PW = 80μs	
I <sub>CES</sub>	Zero Gate Voltage Collector Current			250	μA	V <sub>GE</sub> = 0V, V <sub>CE</sub> = 1200V	
			325	675		V <sub>GE</sub> = 0V, V <sub>CE</sub> = 1200V, T <sub>J</sub> = 125°C	
				2000		V <sub>GE</sub> = 0V, V <sub>CE</sub> = 1200V, T <sub>J</sub> = 150°C	
V <sub>FM</sub>	Diode Forward Voltage Drop		1.76	2.06	V	I <sub>C</sub> = 25A	8
			1.86	2.17		I <sub>C</sub> = 30A	
			1.87	2.18		I <sub>C</sub> = 25A, T <sub>J</sub> = 125°C	
			2.01	2.40		I <sub>C</sub> = 30A, T <sub>J</sub> = 125°C	
I <sub>GES</sub>	Gate-to-Emitter Leakage Current			±100	nA	V <sub>GE</sub> = ±20V	

## Switching Characteristics @ T<sub>J</sub> = 25°C (unless otherwise specified)

	Parameter	Min.	Typ.	Max.	Units	Conditions	Fig.
Q <sub>g</sub>	Total Gate charge (turn-on)		169	254	nC	I <sub>C</sub> = 25A	23
Q <sub>ge</sub>	Gate - Emitter Charge (turn-on)		19	29		V <sub>CC</sub> = 600V	CT1
Q <sub>gc</sub>	Gate - Collector Charge (turn-on)		82	123		V <sub>GE</sub> = 15V	
E <sub>on</sub>	Turn-On Switching Loss		1066	1250	μJ	I <sub>C</sub> = 25A, V <sub>CC</sub> = 600V	CT4
E <sub>off</sub>	Turn-Off Switching Loss		1493	1800		V <sub>GE</sub> = 15V, R <sub>g</sub> = 5Ω, L = 200μH	WF1
E <sub>tot</sub>	Total Switching Loss		2559	3050		T <sub>J</sub> = 25°C, Energy losses include tail and diode reverse recovery	WF2
E <sub>on</sub>	Turn-on Switching Loss		1660	1856	μJ	I <sub>C</sub> = 25A, V <sub>CC</sub> = 600V	13, 15
E <sub>off</sub>	Turn-off Switching Loss		2118	2580		V <sub>GE</sub> = 15V, R <sub>g</sub> = 5Ω, L = 200μH	CT4
E <sub>tot</sub>	Total Switching Loss		3778	4436		T <sub>J</sub> = 125°C, Energy losses include tail and diode reverse recovery	WF1 & 2
td(on)	Turn - on delay time		50	65	ns	I <sub>C</sub> = 25A, V <sub>CC</sub> = 600V	14, 16
tr	Rise time		25	35		V <sub>GE</sub> = 15V, R <sub>g</sub> = 5Ω, L = 200μH	CT4
td(off)	Turn - off delay time		210	230		T <sub>J</sub> = 125°C,	WF1
tf	Fall time		60	75			WF2
C <sub>ies</sub>	Input Capacitance		2200		pF	V <sub>GE</sub> = 0V	22
C <sub>oes</sub>	Output Capacitance		210			V <sub>CC</sub> = 30V	
C <sub>res</sub>	Reverse Transfer Capacitance		85			f = 1.0 MHz	
RBSOA	Reverse bias safe operating area	FULL SQUARE				T <sub>J</sub> = 150°C, I <sub>C</sub> = 120A V <sub>CC</sub> = 1000V, V <sub>P</sub> = 1200V R <sub>g</sub> = 5Ω, V <sub>GE</sub> = +15V to 0 V	4 CT2
SCSOA	Short Circuit Safe Operating Area	10	----	----	μs	T <sub>J</sub> = 150°C V <sub>CC</sub> = 900V, V <sub>P</sub> = 1200V R <sub>g</sub> = 5Ω, V <sub>GE</sub> = +15V to 0 V	CT3 WF4
E <sub>rec</sub>	Reverse recovery energy of the diode		1820	2400	μJ	T <sub>J</sub> = 125°C	17,18,19
trr	Diode Reverse recovery time		300		ns	V <sub>CC</sub> = 600V, I <sub>C</sub> = 25A	20, 21
I <sub>rr</sub>	Peak Reverse Recovery Current		34	38	A	V <sub>GE</sub> = 15V, R <sub>g</sub> = 5Ω, L = 200μH	CT4, WF3
Le	Internal Emitter Inductance		13		nH	Measured 5 mm from the package.	

# IRGP30B120KD-E

Fig.1 - Maximum DC Collector Current vs. Case Temperature

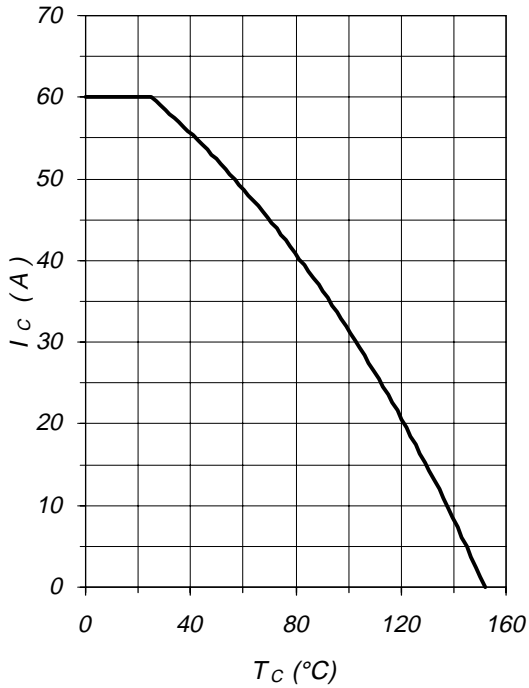

Fig.2 - Power Dissipation vs. Case Temperature

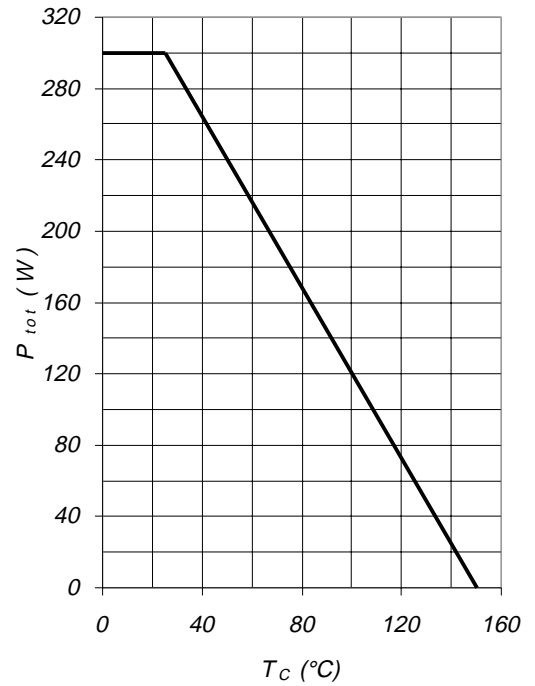

Fig.3 - Forward SOA  
 $T_C=25^{\circ}C$ ;  $T_j \leq 150^{\circ}C$

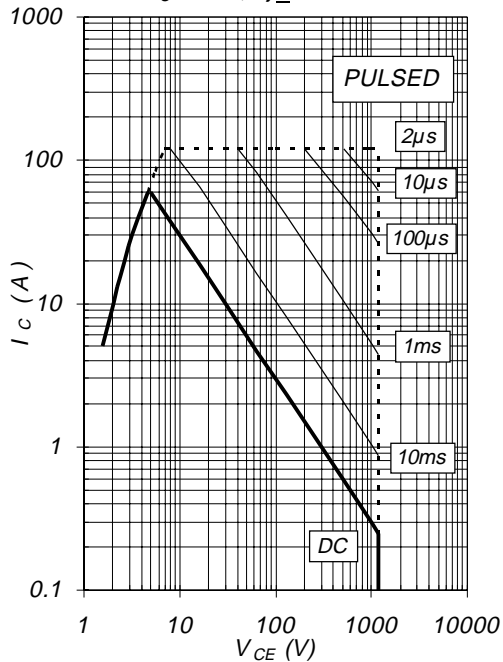

Fig.4 - Reverse Bias SOA  
 $T_j = 150^{\circ}C$ ,  $V_{GE} = 15V$

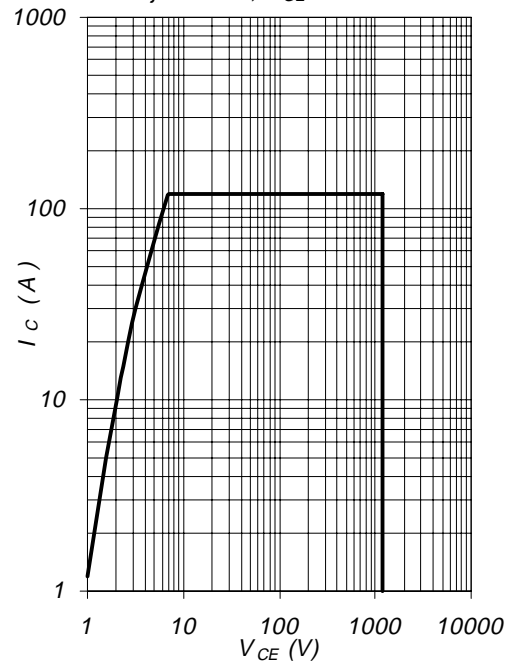

Fig.5 - Typical IGBT Output Characteristics  
 $T_j = -40^\circ\text{C}; t_p = 300\mu\text{s}$

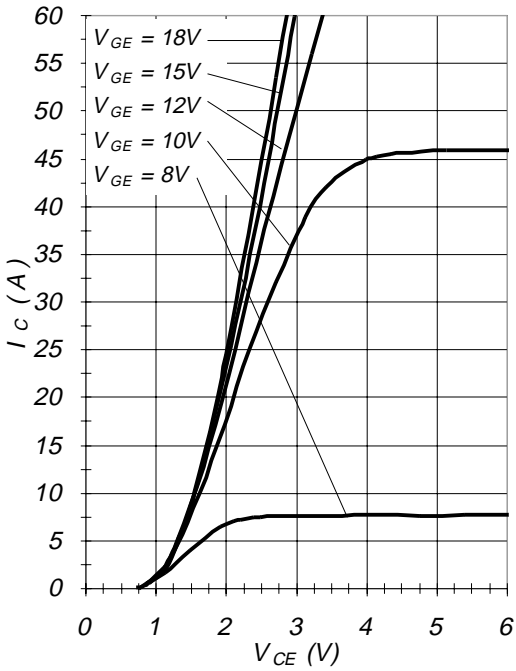

Fig.6 - Typical IGBT Output Characteristics  
 $T_j = 25^\circ\text{C}; t_p = 300\mu\text{s}$

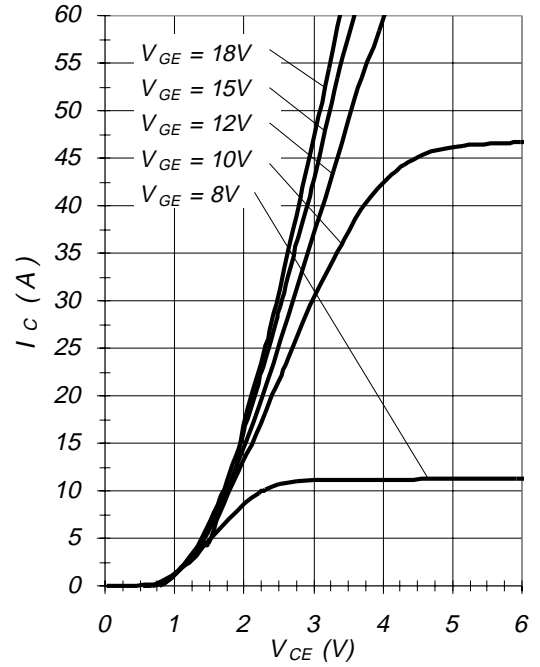

Fig.7 - Typical IGBT Output Characteristics  
 $T_j = 125^\circ\text{C}; t_p = 300\mu\text{s}$

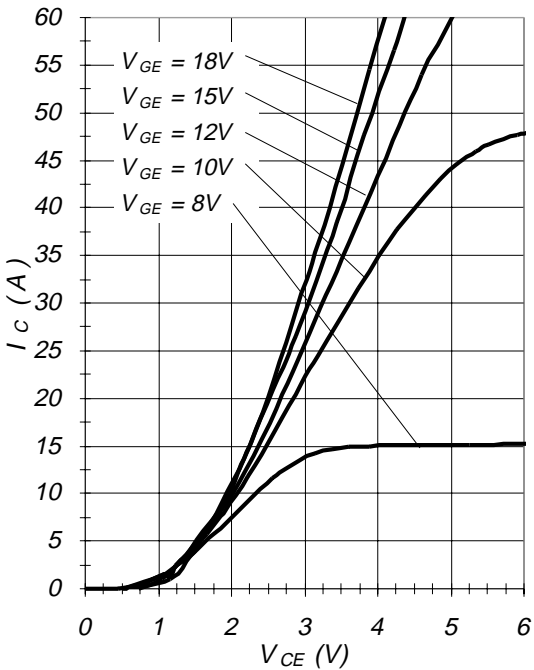
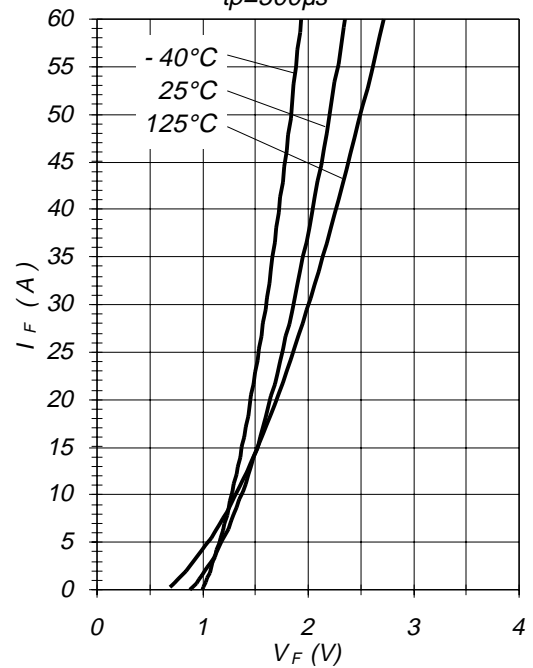

Fig.8 - Typical Diode Forward Characteristic  
 $t_p = 300\mu\text{s}$



# IRGP30B120KD-E

Fig.9 - Typical  $V_{CE}$  vs  $V_{GE}$   
 $T_j = -40^\circ\text{C}$

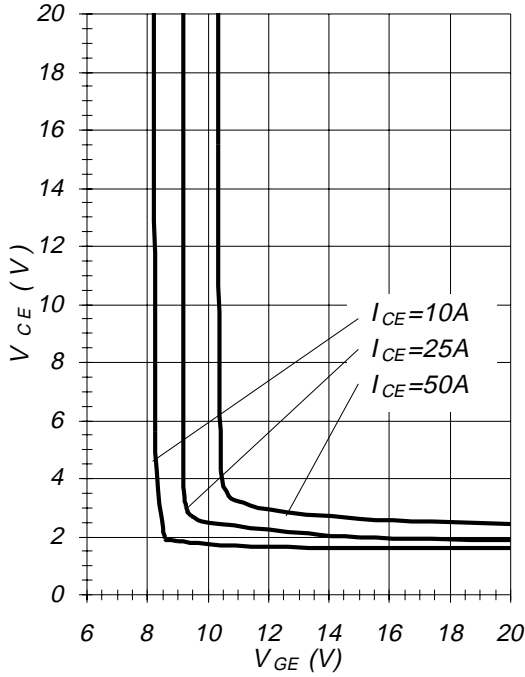

Fig.10 - Typical  $V_{CE}$  vs  $V_{GE}$   
 $T_j = 25^\circ\text{C}$

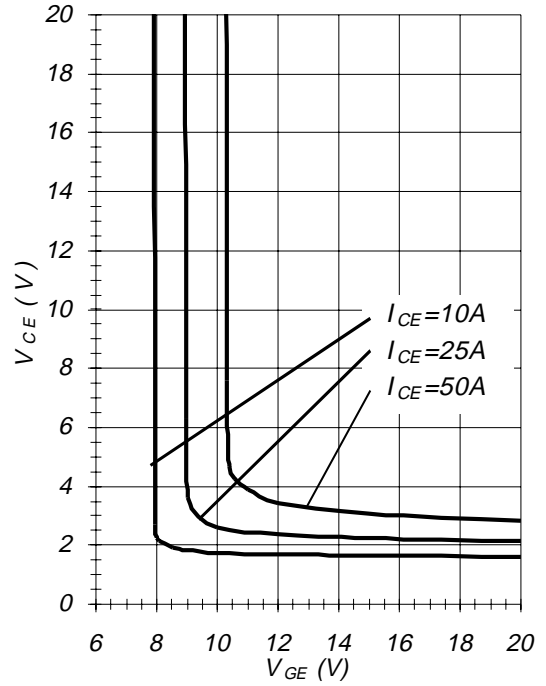

Fig.11 - Typical  $V_{CE}$  vs  $V_{GE}$   
 $T_j = 125^\circ\text{C}$

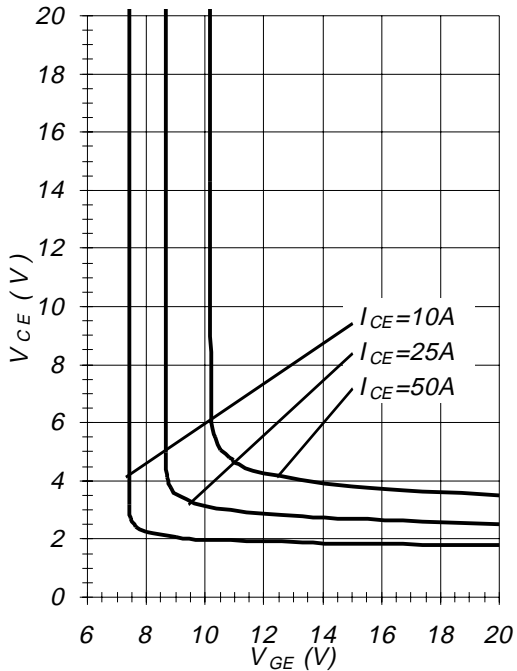
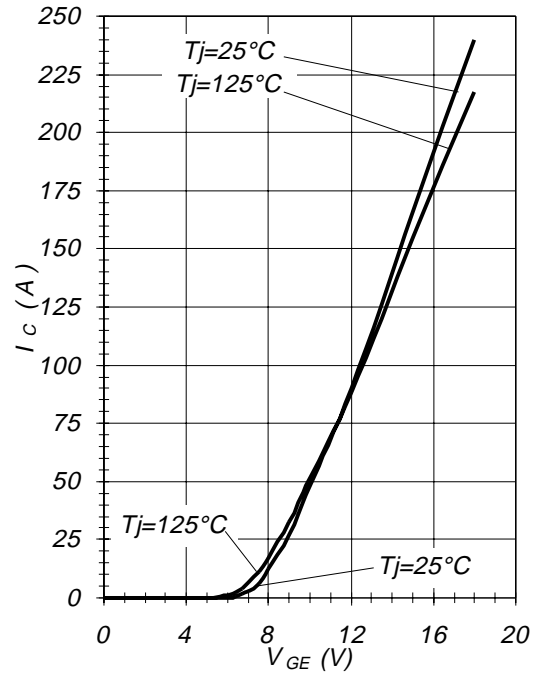

Fig.12 - Typ. Transfer Characteristics  
 $V_{CE} = 20\text{V}$ ;  $t_p = 20\mu\text{s}$



# IRGP30B120KD-E

Fig.13 - Typical Energy Loss vs  $I_C$   
 $T_j=125^\circ\text{C}$ ;  $L=200\mu\text{H}$ ;  $V_{CE}=600\text{V}$ ;  
 $R_g=22\ \Omega$ ;  $V_{GE}=15\text{V}$

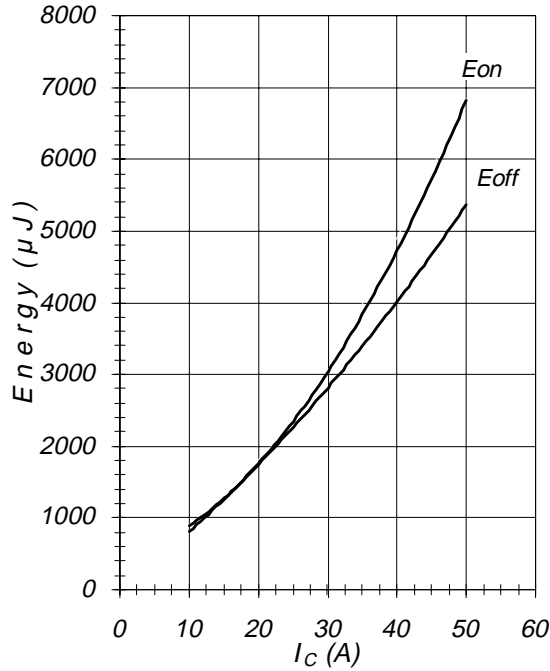

Fig.14 - Typical Switching Time vs  $I_C$   
 $T_j=125^\circ\text{C}$ ;  $L=200\mu\text{H}$ ;  $V_{CE}=600\text{V}$ ;  
 $R_g=22\ \Omega$ ;  $V_{GE}=15\text{V}$

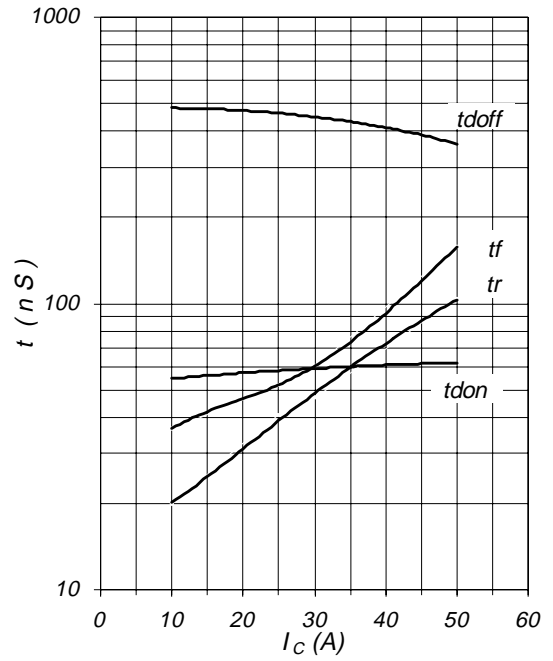

Fig.15 - Typical Energy Loss vs  $R_g$   
 $T_j=125^\circ\text{C}$ ;  $L=200\mu\text{H}$ ;  $V_{CE}=600\text{V}$ ;  
 $I_{CE}=25\text{A}$ ;  $V_{GE}=15\text{V}$

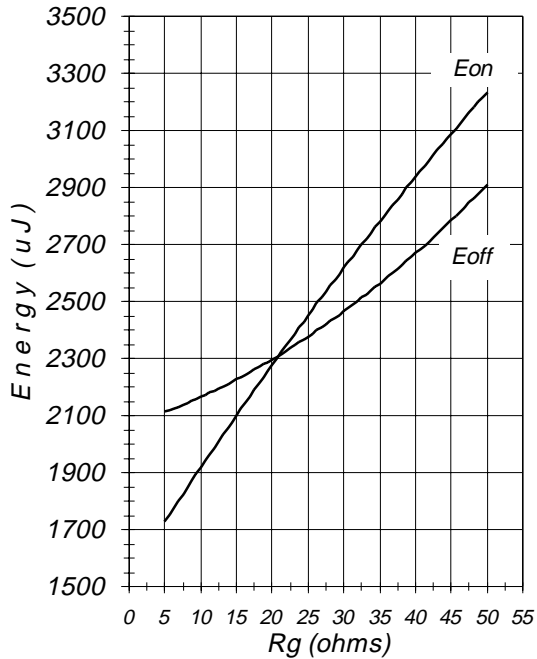
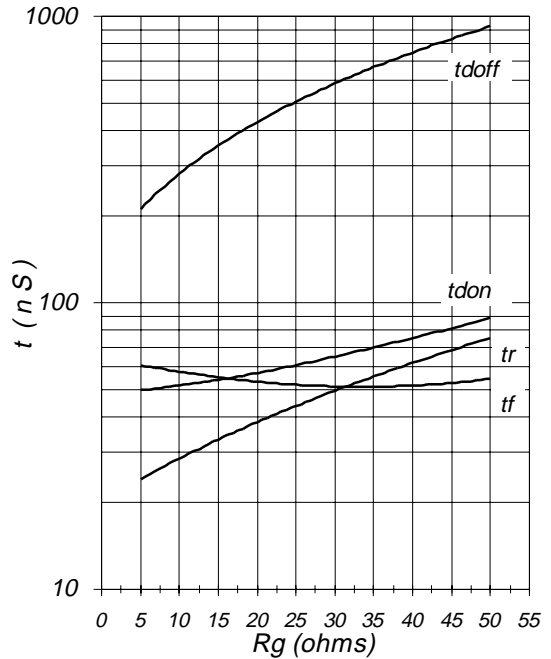

Fig.16 - Typical Switching Time vs  $R_g$   
 $T_j=125^\circ\text{C}$ ;  $L=200\mu\text{H}$ ;  $V_{CE}=600\text{V}$ ;  
 $I_{CE}=25\text{A}$ ;  $V_{GE}=15\text{V}$



# IRGP30B120KD-E

Fig.17 - Typical Diode  $I_{RR}$  vs  $I_F$   
 $T_j=125^\circ\text{C}$

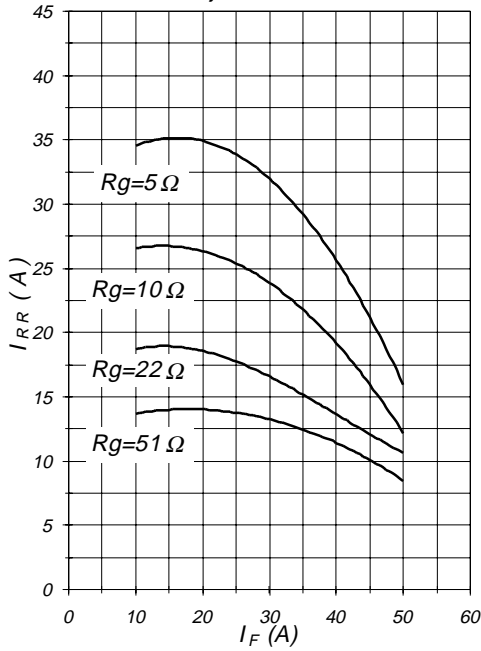

Fig.18 - Typical Diode  $I_{RR}$  vs  $R_g$   
 $T_j=125^\circ\text{C}; I_F=25\text{A}$

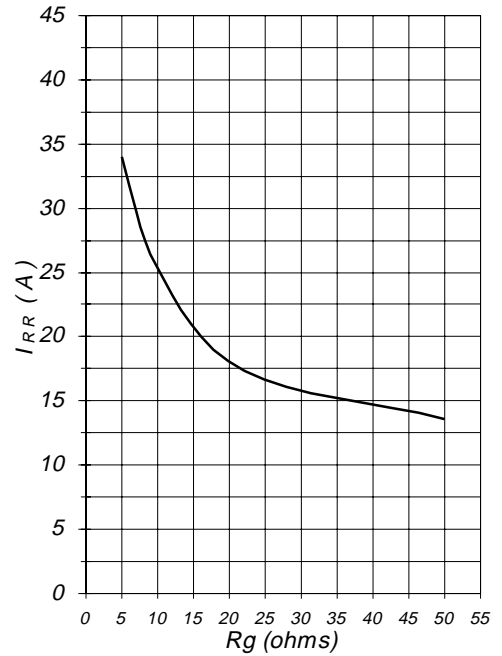

Fig.19 - Typical Diode  $I_{RR}$  vs  $di_F/dt$   
 $V_{CC}=600\text{V}; V_{GE}=15\text{V}$   
 $I_F=25\text{A}; T_j=125^\circ\text{C}$

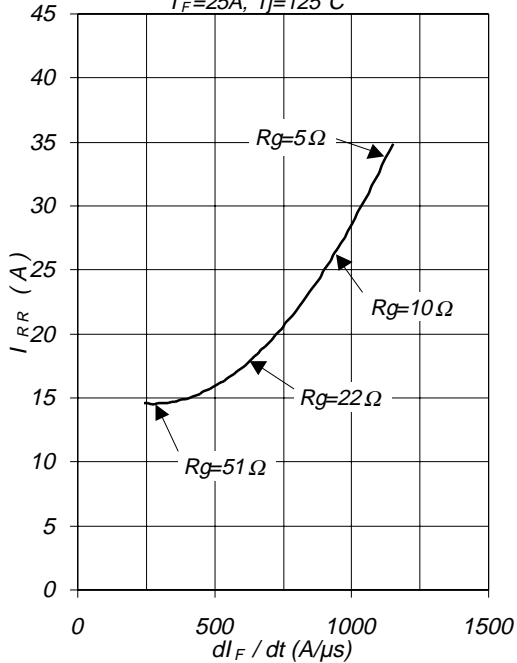

Fig.20 - Typical Diode  $Q_{RR}$   
 $V_{CC}=600\text{V}; V_{GE}=15\text{V}; T_j=125^\circ\text{C}$

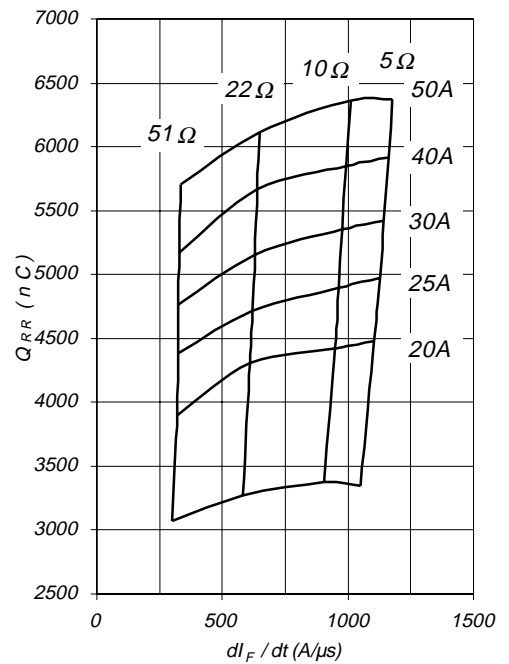

Fig.21 - Typ. Diode  $E_{rec}$  vs.  $I_F$   
 $T_j=125^\circ\text{C}$

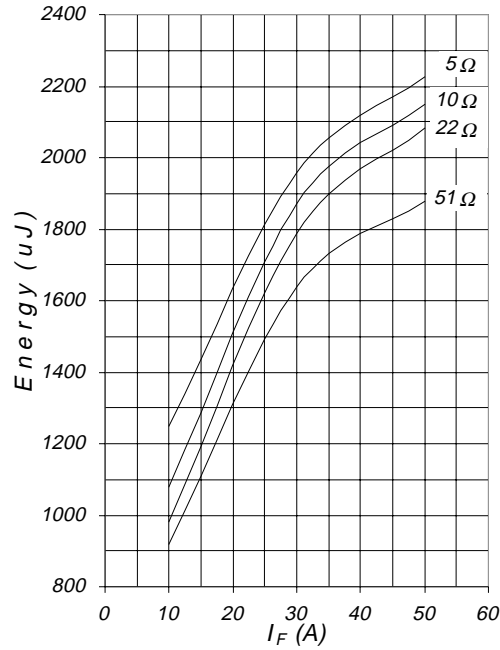

Fig.22 - Typical Capacitance vs  $V_{CE}$   
 $V_{GE}=0\text{V}$ ;  $f=1\text{MHz}$

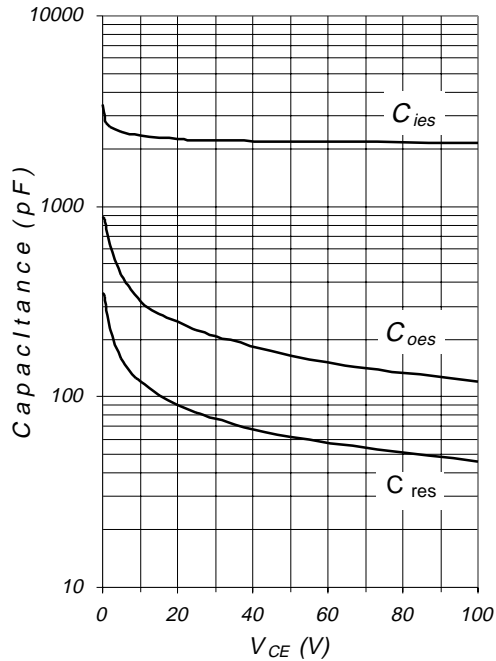

Fig.23 - Typ. Gate Charge vs.  $V_{GE}$   
 $I_C=25\text{A}$ ;  $L=600\ \mu\text{H}$

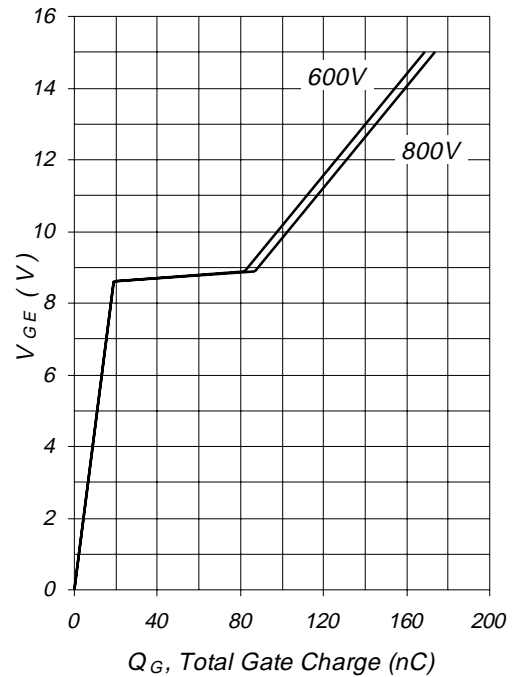
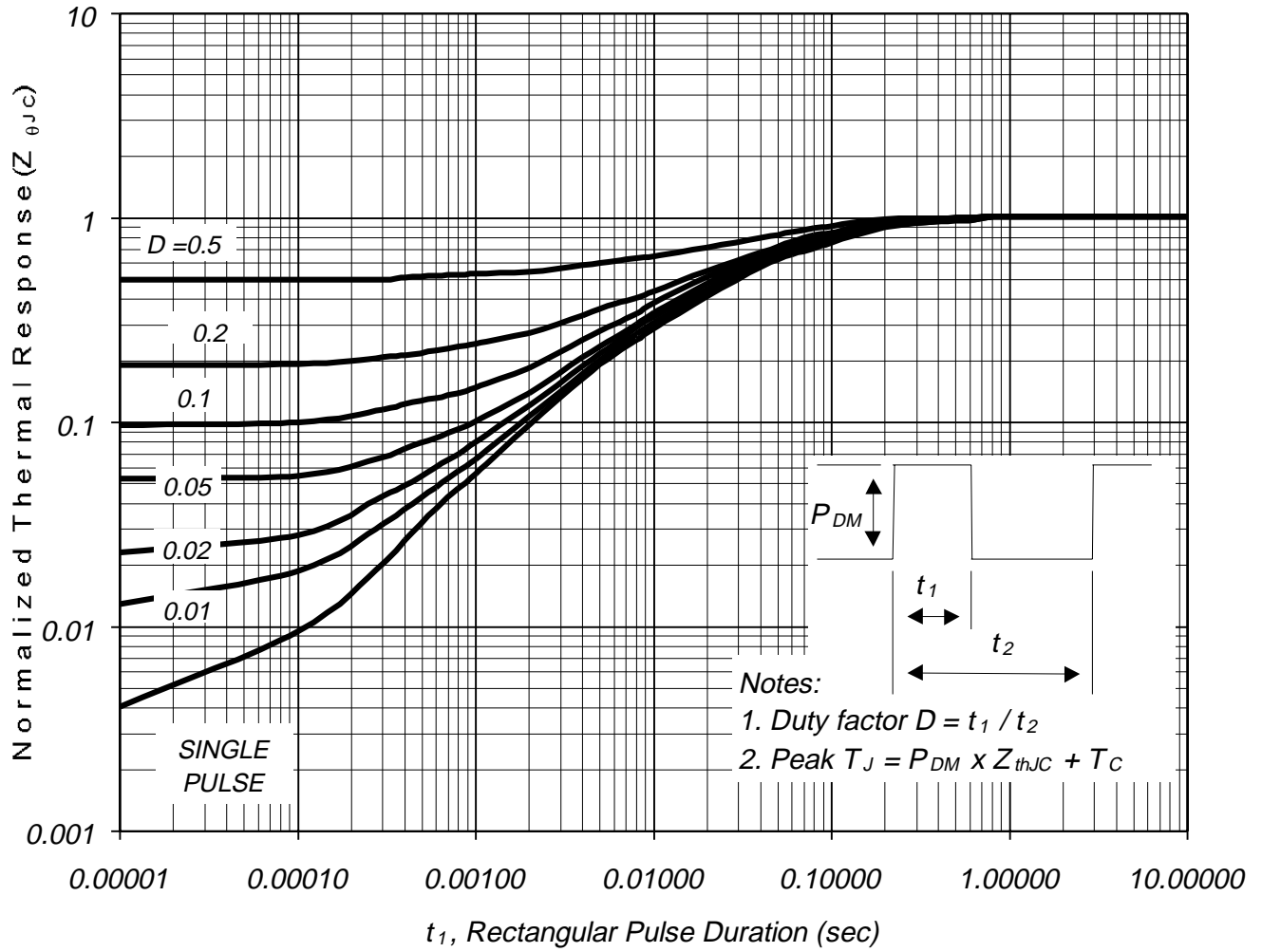
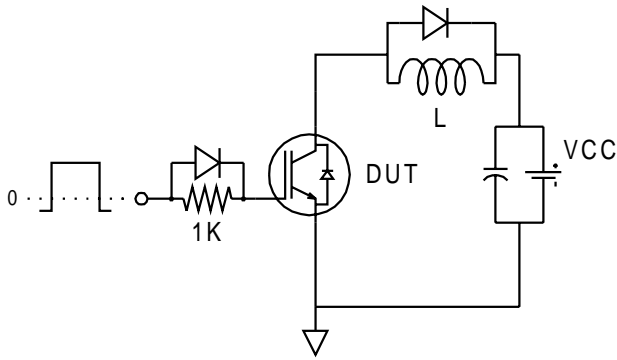

Fig.24 - Normalized Transient Thermal Impedance, Junction-to-Case



# IRGP30B120KD-E

**Fig. CT.1 - Gate Charge Circuit (turn-off)**



**Fig. CT.2 - RBSOA Circuit**

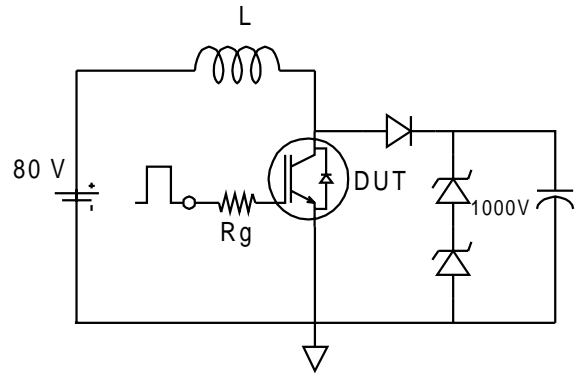

**Fig. CT.3 - S.C. SOA Circuit**

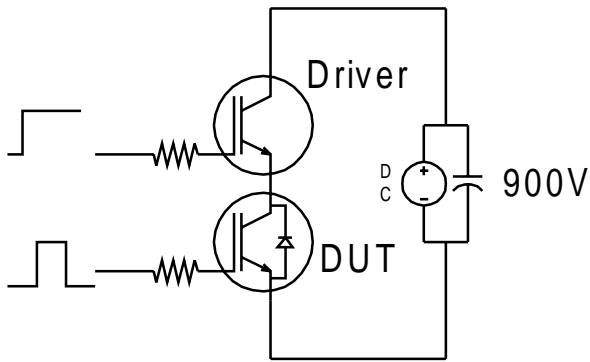

**Fig. CT.4 - Switching Loss Circuit**

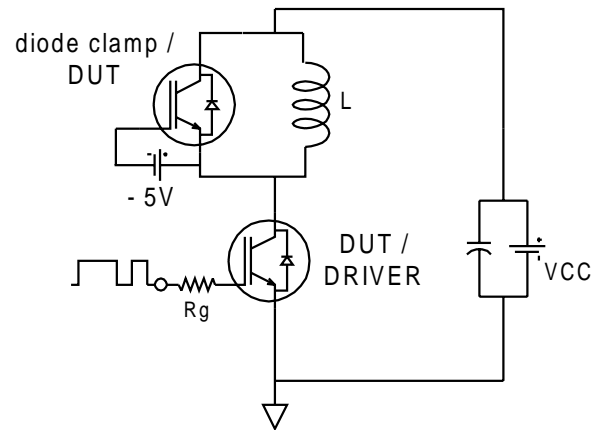

**Fig. CT.5 - Resistive Load Circuit**

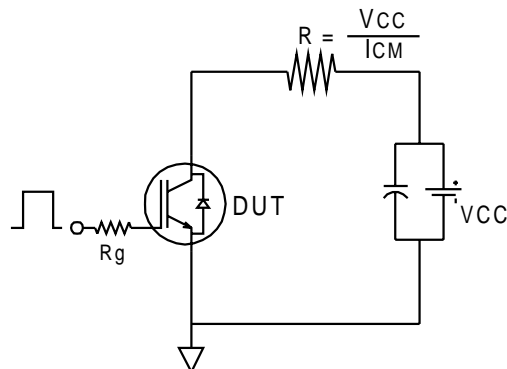

# IRGP30B120KD-E

Fig. WF.1 - Typ. Turn-off Loss Waveform  
@  $T_j=125^\circ\text{C}$  using Fig. CT.4

Fig. WF.2 - Typ. Turn-on Loss Waveform  
@  $T_j=125^\circ\text{C}$  using Fig. CT.4

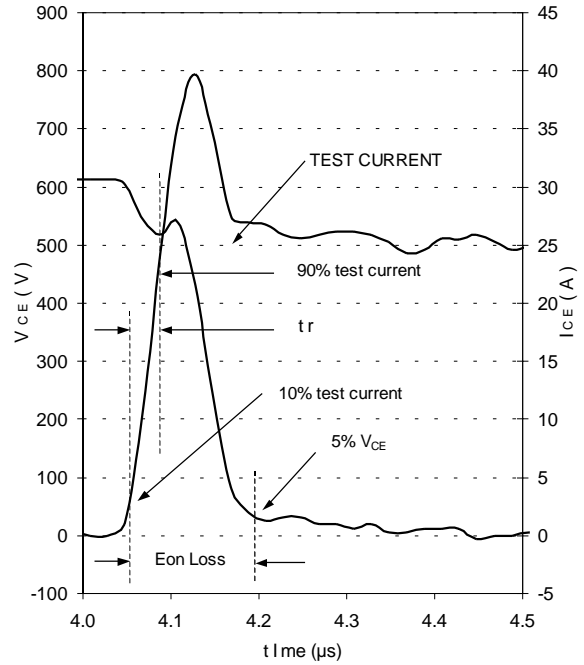
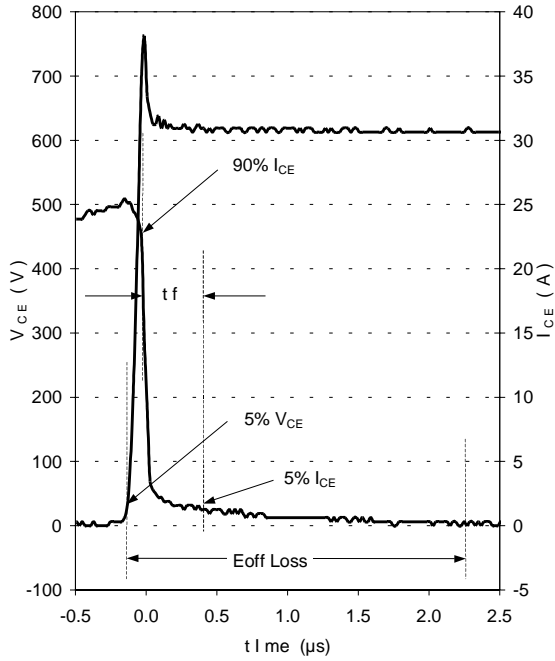
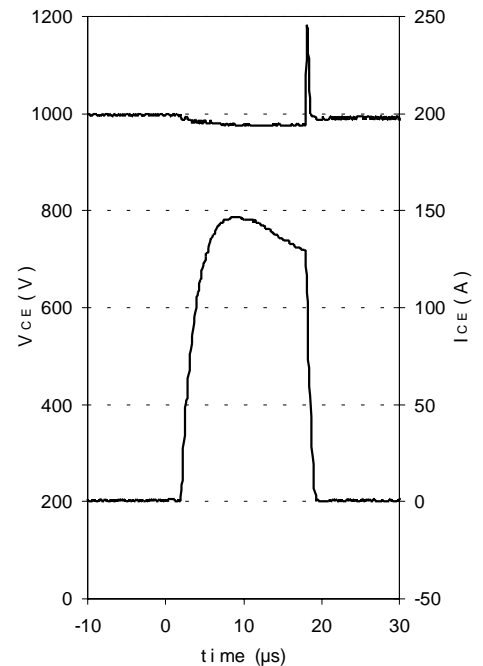
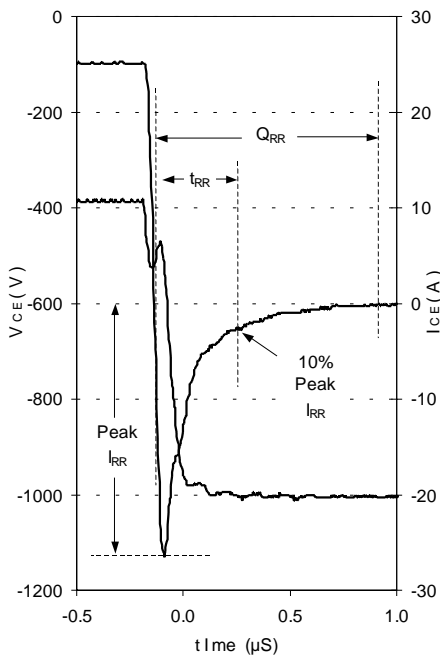

Fig. WF.3 - Typ. Diode Recovery Waveform  
@  $T_j=125^\circ\text{C}$  using Fig. CT.4

Fig. WF.4 - Typ. S.C. Waveform  
@  $T_C=150^\circ\text{C}$  using Fig. CT.3



# IRGP30B120KD-E

## TO-247AD Case Outline and Dimensions

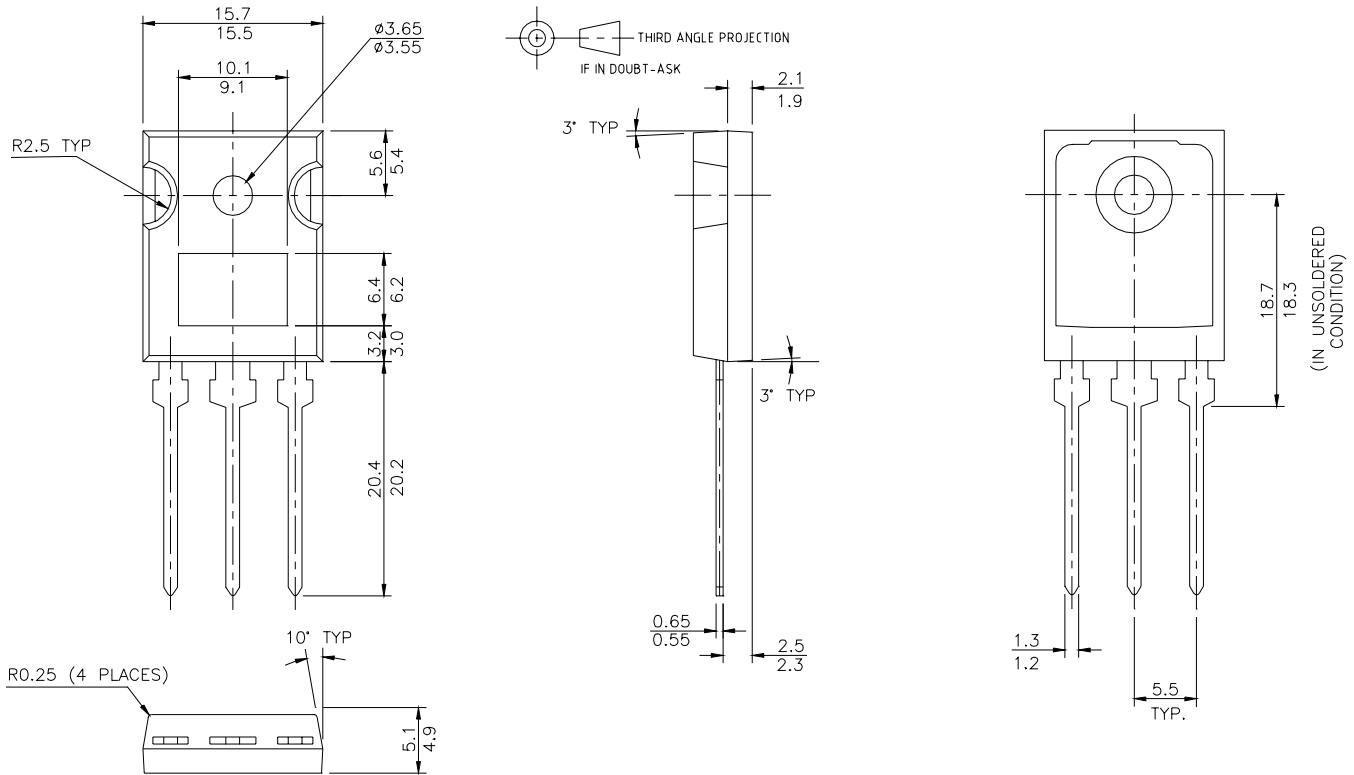



LittleDiode supplies new, hard to find or obsolete electronic components and semiconductors all over the world.

With over two million different components listed you are sure to find the part you need.

Feel free to visit us today at our online store:

[LittleDiode.com](http://LittleDiode.com)

Looking forward to providing you with the best possible service.