

SIEMENS

Hall-Effect Vane Switch

HKZ 121

Features

Bipolar IC

- Contactless switch with open collector output (40 mA)
- Static switching
- High switching frequency
- Hermetically sealed with plastic
- Unaffected by dirt, light, vibration
- Large temperature and voltage range
- Integrated overvoltage protection
- High interference immunity
- Integrated capacitors for EMI protection

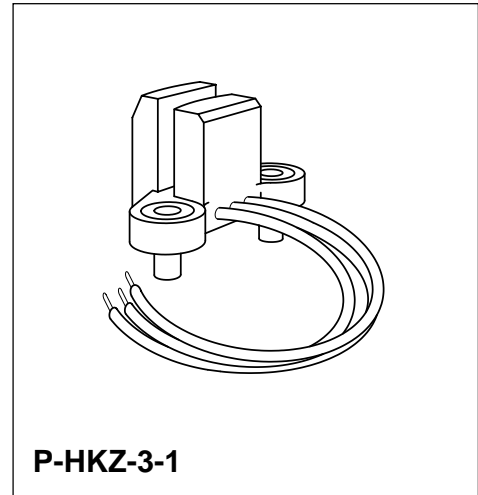

Type	Ordering Code	Package
HKZ 121	Q67000-A9097-A401	P-HKZ-3-1

The Hall-effect vane switch HKZ 121 is a contactless switch consisting of a monolithic integrated Hall-effect circuit and a special magnetic circuit hermetically sealed in a plastic package. The switch is actuated by a soft-iron vane which is passed through the air gap between magnet and Hall sensor.

The main application field is in cars, i.e. as a breakerless trigger in electronic ignition systems. Numerous industrial applications can be found in control engineering, especially in those areas where switches must operate maintenance-free under harsh environmental conditions (e.g. rpm sensor, limit switch, position sensor, speed measurement, shaft encoder, scanning of coding disks, etc.).

Function

The Hall-effect switch is actuated by a soft-iron vane that passes through the air gap between magnet and Hall-effect sensor. The vane short-circuits the magnetic flux before the hall-effect sensor, as shown below. The open collector output is conductive (low) when the vane is outside the air gap, and blocks (high) when the vane is introduced into the air gap. The output remains high as long as the vane remains in the air gap. This static function does not require a minimum operating frequency. The output signal shape is independent of the operating frequency.

The circuit features integrated overvoltage protection against most of the voltage peaks occurring in automotive and industrial applications. The output stage has a Schmitt trigger characteristic. Most electronic circuits can be driven directly due to the open collector output current of max. 40 mA.

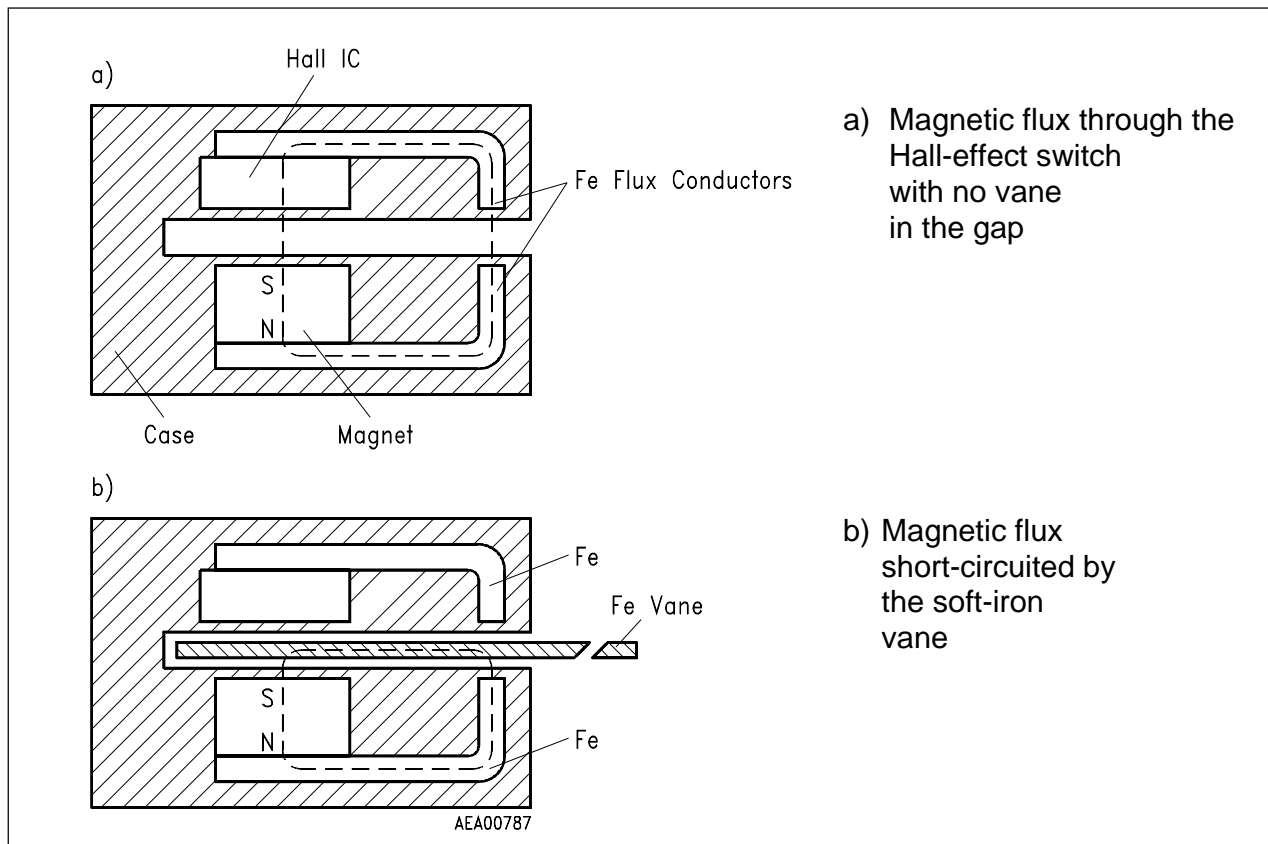

Principle of Operation

Mechanical Characteristics

The Hall-effect vane switch is hermetically sealed in a special plastic package, so that it can also be used under harsh environmental conditions. The package is waterproof, vibration-resistant and resistant to gasoline, oil and salt. Two tubular rivets are incorporated in the package to mount the sensor on its carrier plate. The circuit has three flexible leads for power supply, output and ground.

Application Notes

The output current of the "open collector" must be limited to the maximum permissible value by a load resistor adapted to the application.

For optimum efficiency of the integrated overvoltage protection, it is suggested that a resistor of approx. 100 Ω be provided in the component's power supply to limit the current.

Absolute Maximum Ratings

Parameter	Symbol	Limit Values		Unit	Test Condition
		min.	max.		
Supply voltage	V_S	- 1.2	24	V	-
			30	V	$T_A = 25\text{ °C}$
Output voltage in OFF-state	V_Q	- 0.8	30	V	-
Inverse supply current (limited externally)	$-I_S$	-	200	mA	$T_A \leq 80\text{ °C}$ $t \leq 1\text{ h}$
Output current	I_Q	-	40	mA	without vane
Inverse output current	$-I_Q$	-	30	mA	
Ambient temperature	T_A	- 40	135	°C	-
Storage temperature	T_{stg}	- 40	150	°C	-
Thermal resistance system - air	$R_{th SA}$	-	170	K/W	-

Operating Range

Supply voltage	V_S	4.5	24	V	-
Ambient temperature	T_A	- 40	130	°C	-
Vane ¹⁾ : thickness	a	0.5		mm	-
width	b	8		mm	-
gap length	c	8		mm	-
immersion depth	h	4.6	9	mm	-
gap height	d	7.3 - h		mm	-

1) see Figure Mechanical Measurement Conditions

Characteristics

$V_S = 5 \text{ V to } 18 \text{ V}$, $T_A = -30 \text{ to } 130 \text{ }^\circ\text{C}$

Parameter	Symbol	Limit Values		Unit	Test Condition
		min.	max.		
Output saturation voltage	$V_{Q \text{ sat}}$	–	– 0.4 0.6	– V V	without vane $I_Q = 40 \text{ mA}$ $T_A = -30 \text{ to } 110 \text{ }^\circ\text{C}$ $T_A = 110 \text{ to } 130 \text{ }^\circ\text{C}$
Output reverse current	$I_{Q \text{ R}}$	–	10	μA	with vane
Supply current	I_S	–	12	mA	without vane
Fall time	t_{HL}	–	1	μs	$I_Q = 40 \text{ mA}$
Overvoltage protection					
– Supply voltage (V_S)	V_{SZ}	32	42	V	$I_S = 16 \text{ mA}$
– Output (V_Q)	V_{S0}	32	42	V	$I_S = 16 \text{ mA}$

Switching Point Characteristics

Definitions

In most applications, the switching point is set exactly by mechanical adjustment, thus compensating all mechanical tolerances in the system including the scatter of the Hall-effect vane switch. For the function of the device in operation, only the deviations of those characteristics are important on temperature and operating voltage.

The characteristic values of the switching points are, therefore, not directly referred to the mechanical dimensions of the vane switch, but to an electrically defined symmetry B_0 according to formula 1):

$$1) B_0 = (\text{ON}_{\text{left}} + \text{OFF}_{\text{left}} + \text{ON}_{\text{right}} + \text{OFF}_{\text{right}}): 4$$

$$B_0 = A_0 \pm 0.3 \text{ mm}$$

The definition of the operate and release points is shown the following figure.

Operate point f_{ON} is obtained by subtracting the measured ON operate value from the reference point B_0 :

$$2) f_{\text{ON}} = \text{ON}_{\text{right}} - B_0 = B_0 - \text{ON}_{\text{left}}$$

The release point f_{OFF} is calculated from the difference between the appropriate ON and OFF points:

$$3) f_{\text{OFF}} = \text{ON}_{\text{right}} - \text{OFF}_{\text{right}} = \text{OFF}_{\text{left}} - \text{ON}_{\text{left}}$$

$f_{\text{ON}0}$ and $f_{\text{OFF}0}$ are the switching points measured for the individual component under normal conditions ($V_S = 12 \text{ V}$, $T_A = 25 \text{ }^\circ\text{C}$) within the characteristic device deviation.

The deviations of the operate and release points are defined according to 4):

$$4) \Delta f_{\text{ON}} = f_{\text{ON}} - f_{\text{ON}0}$$

$$\Delta f_{\text{OFF}} = f_{\text{OFF}} - f_{\text{OFF}0}$$

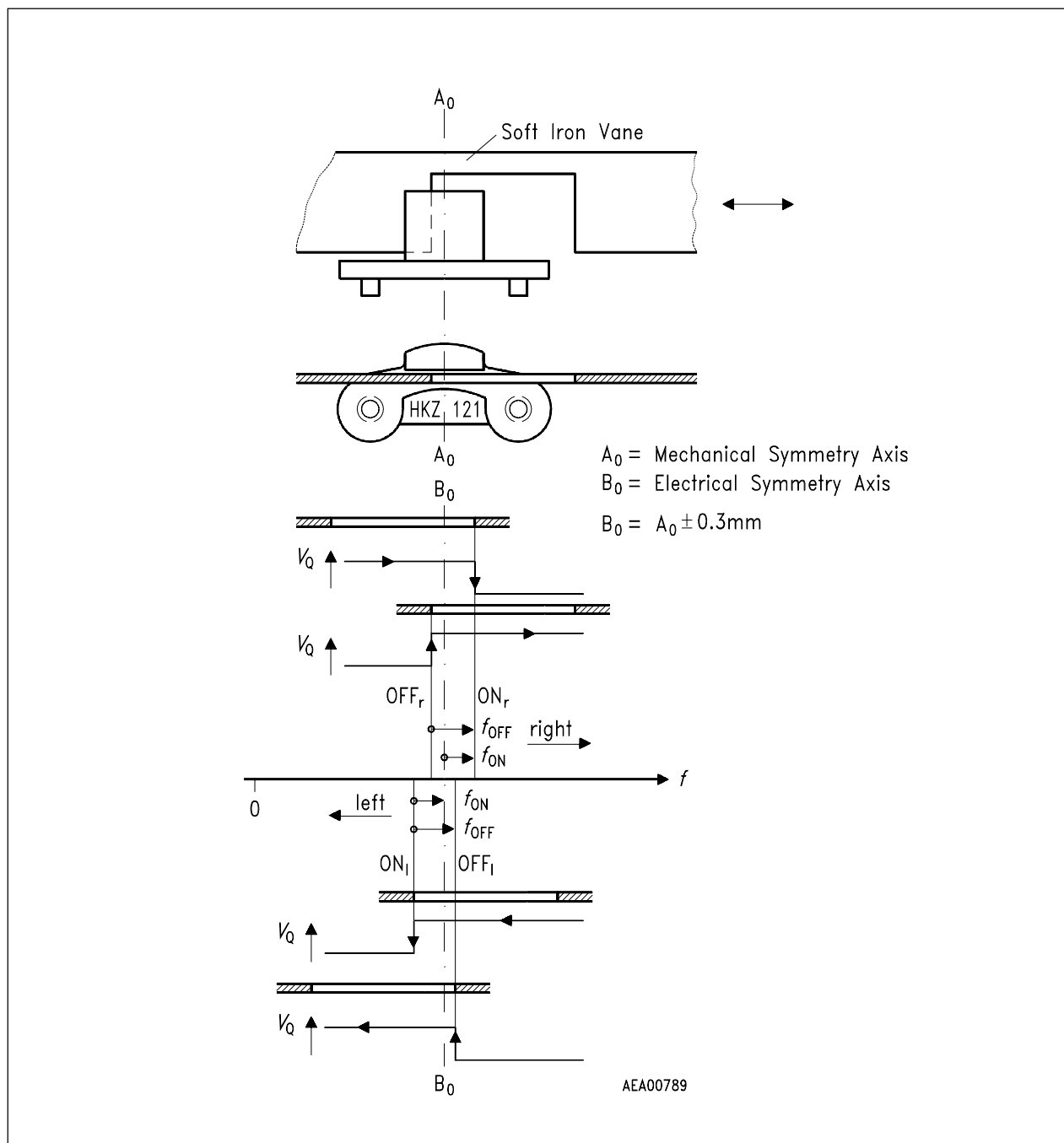

Switching Point Definitions

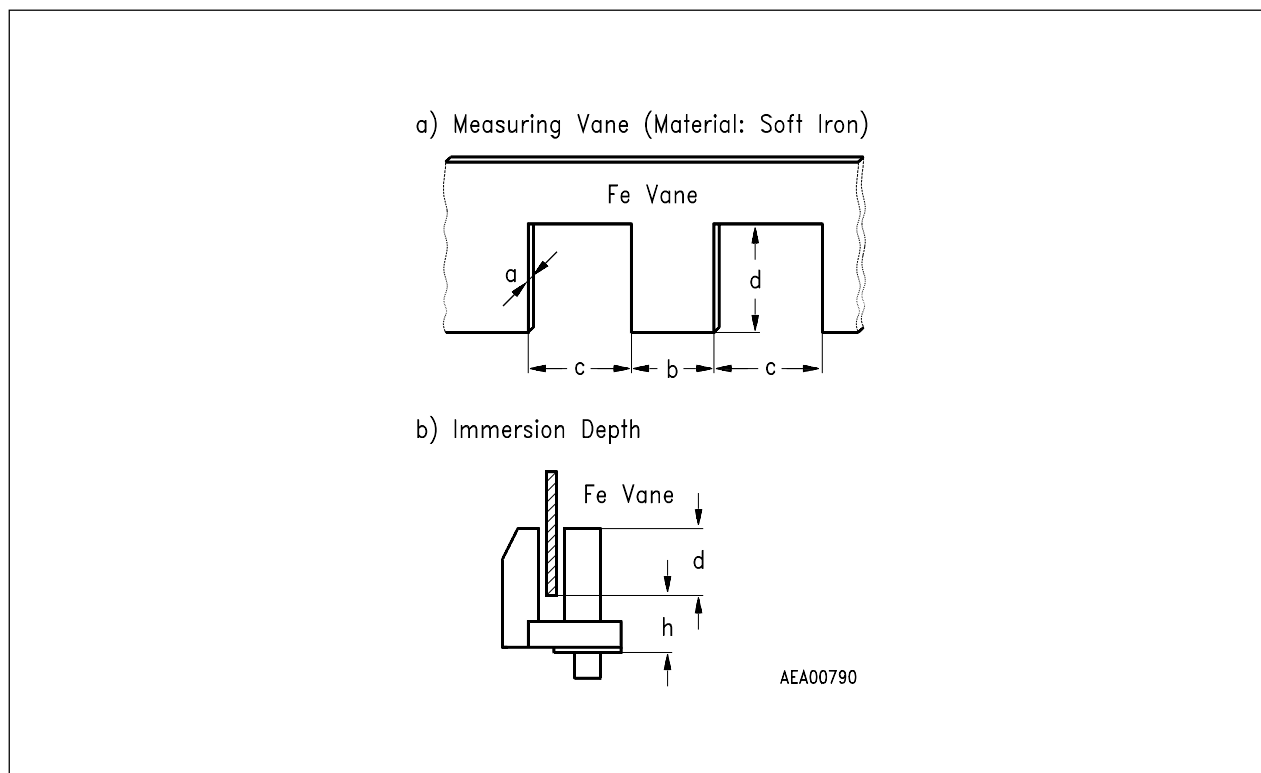

Mechanical Measurement Conditions

Switching Point Characteristics

Vane: a = 0.75 mm, b = 8 mm, c = 10 mm

Position: center of air gap

V_S = 5 V to 18 V

Parameter	Symbol	Limit Values			Unit	Test Condition
		min.	typ.	max.		
HKZ 121 Operate point Deviations	f_{ON0}	0.85	1.45	2.05	mm	V _S = 12 V, T _A = 25 °C
	Δf_{ON}	- 0.4	0.15	0.7	mm	T _A = - 30 to 25 °C
		- 0.2	0.15	0.4	mm	T _A = 25 to 80 °C
		- 0.4	0.2	0.7	mm	T _A = 80 to 130 °C
Release point Deviations	f_{OFF0}	1.54	2.54	3.54	mm	V _S = 12 V, T _A = 25 °C
	Δf_{OFF}	- 0.8	0.3	1.4	mm	T _A = - 30 to 25 °C
		- 0.4	0.3	0.8	mm	T _A = 25 to 80 °C
		- 0.8	0.4	1.4	mm	T _A = 80 to 130 °C



LittleDiode supplies new, hard to find or obsolete electronic components and semiconductors all over the world.

With over two million different components listed you are sure to find the part you need.

Feel free to visit us today at our online store:

LittleDiode.com

Looking forward to providing you with the best possible service.