

MECHANICAL DATA

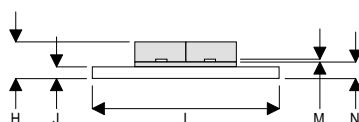
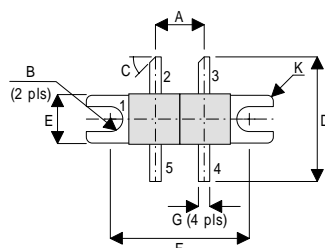

DK

PIN 1 SOURCE (COMMON) PIN 2 DRAIN 1
 PIN 3 DRAIN 2 PIN 4 GATE 2
 PIN 5 GATE 1

DIM	mm	Tol.	Inches	Tol.
A	6.45	0.13	0.254	0.005
B	1.65R	0.13	0.065R	0.005
C	45°	5°	45°	5°
D	16.51	0.76	0.650	0.03
E	6.47	0.13	0.255	0.005
F	18.41	0.13	0.725	0.005
G	1.52	0.13	0.060	0.005
H	4.82	0.25	0.190	0.010
I	24.76	0.13	0.975	0.005
J	1.52	0.13	0.060	0.005
K	0.81R	0.13	0.032R	0.005
M	0.13	0.02	0.005	0.001
N	2.16	0.13	0.085	0.005

**GOLD METALLISED
 MULTI-PURPOSE SILICON
 DMOS RF FET
 20W – 28V – 1GHz
 PUSH-PULL**

FEATURES

- SIMPLIFIED AMPLIFIER DESIGN
- SUITABLE FOR BROAD BAND APPLICATIONS
- VERY LOW C_{rss}
- SIMPLE BIAS CIRCUITS
- LOW NOISE
- HIGH GAIN – 10 dB MINIMUM

APPLICATIONS

- HF/VHF/UHF COMMUNICATIONS
 from 1MHz to 2 GHz

ABSOLUTE MAXIMUM RATINGS ($T_{case} = 25^{\circ}C$ unless otherwise stated)

P_D	Power Dissipation	83W
BV_{DSS}	Drain – Source Breakdown Voltage *	65V
BV_{GSS}	Gate – Source Breakdown Voltage *	±20V
$I_{D(sat)}$	Drain Current *	4A
T_{stg}	Storage Temperature	-65 to 150°C
T_j	Maximum Operating Junction Temperature	200°C

* Per Side

ELECTRICAL CHARACTERISTICS ($T_{case} = 25^{\circ}C$ unless otherwise stated)

Parameter	Test Conditions	Min.	Typ.	Max.	Unit
PER SIDE					
BV_{DSS} Drain–Source Breakdown Voltage	$V_{GS} = 0$ $I_D = 10mA$	65			V
I_{DSS} Zero Gate Voltage Drain Current	$V_{DS} = 28V$ $V_{GS} = 0$			1	mA
I_{GSS} Gate Leakage Current	$V_{GS} = 20V$ $V_{DS} = 0$			1	μA
$V_{GS(th)}$ Gate Threshold Voltage *	$I_D = 10mA$ $V_{DS} = V_{GS}$	1		7	V
g_{fs} Forward Transconductance *	$V_{DS} = 10V$ $I_D = 0.8A$	0.72			S
TOTAL DEVICE					
G_{PS} Common Source Power Gain	$P_O = 20W$	10			dB
η Drain Efficiency	$V_{DS} = 28V$ $I_{DQ} = 0.8A$	40			%
VSWR Load Mismatch Tolerance	$f = 1GHz$	20:1			—
PER SIDE					
C_{iss} Input Capacitance	$V_{DS} = 0$ $V_{GS} = -5V$ $f = 1MHz$			48	pF
C_{oss} Output Capacitance	$V_{DS} = 28V$ $V_{GS} = 0$ $f = 1MHz$			24	pF
C_{rss} Reverse Transfer Capacitance	$V_{DS} = 28V$ $V_{GS} = 0$ $f = 1MHz$			2	pF

* Pulse Test: Pulse Duration = 300 μs , Duty Cycle $\leq 2\%$

HAZARDOUS MATERIAL WARNING

The ceramic portion of the device between leads and metal flange is beryllium oxide. Beryllium oxide dust is highly toxic and care must be taken during handling and mounting to avoid damage to this area.

THESE DEVICES MUST NEVER BE THROWN AWAY WITH GENERAL INDUSTRIAL OR DOMESTIC WASTE.

THERMAL DATA

$R_{THj-case}$	Thermal Resistance Junction – Case	Max. 2.1 $^{\circ}C / W$
----------------	------------------------------------	--------------------------

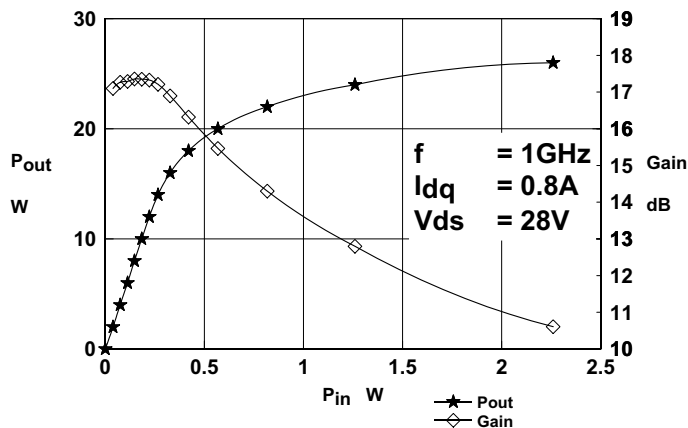

Figure 1

Output Power and Gain vs. Input Power.

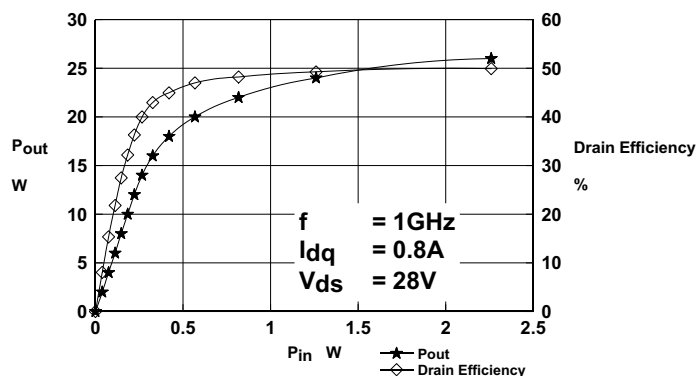

Figure 2

Output Power and efficiency vs. Input Power.

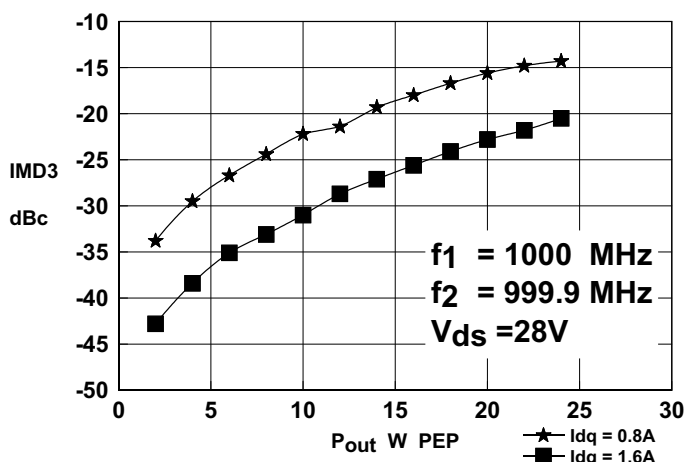

Figure 3

IMD vs. Output Power.

OPTIMUM SOURCE AND LOAD IMPEDANCE

Frequency MHz	Z _S Ω	Z _L Ω
1000MHz	1.3 - j4.6	2.5 - j2.6

Typical S Parameters

! Vds=28V, Idq=0.8A
MHz S MA R 50

!Freq !MHz	S11		S21		S12		S22	
	mag	ang	mag	ang	mag	ang	mag	ang
100	0.841	-122	24.547	98	0.01318	13	0.49	-94
200	0.871	-146	11.482	69	0.01	0	0.61	-125
300	0.891	-156	6.683	52	0.00653	10	0.708	-137
400	0.902	-163	4.365	40	0.00596	49	0.767	-146
500	0.923	-170	3.055	27	0.00891	71	0.813	-155
600	0.933	-174	2.113	22	0.01349	79	0.851	-165
700	0.955	-175	1.758	19	0.01862	85	0.881	-166
800	0.955	-177	1.413	12	0.02344	82	0.902	-170
900	0.966	-179	1.161	5	0.02851	80	0.902	-177
1000	0.955	-177	0.944	3	0.03236	80	0.902	-179

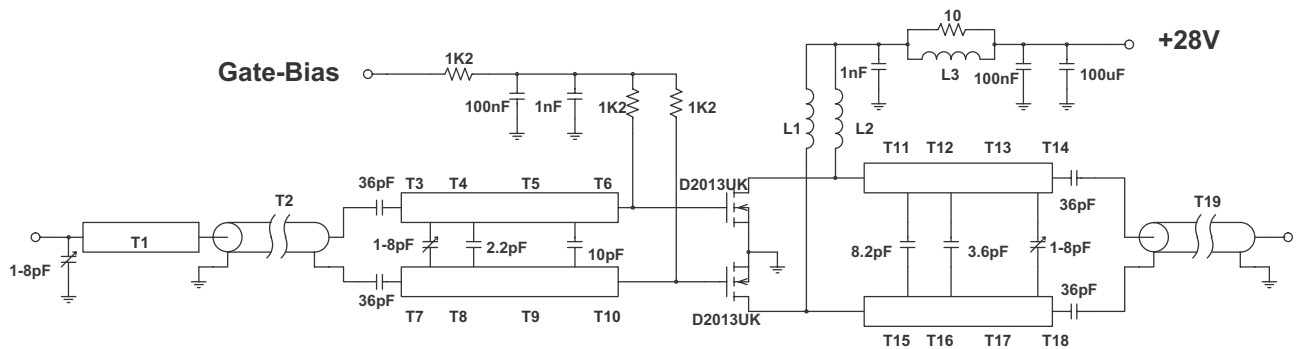

1000MHz Test Fixture

Substrate 0.8mm thick PTFE/glass

All microstrip lines $W = 2.7\text{mm}$

T1	23mm
T2, T19	50MM 50 Ohm UT34 semi-rigid coax
T3, T7	6mm
T4, T8	8mm
T5, T9	15mm
T6, T10	9mm
T11, T15	8mm
T12, T16	7mm
T13, T17	11mm
T14, T18	5mm

L1, L2 6 turns of 24swg enameld copper wire, 3mm i,d.

L3 1.5 turn 24 swg enamelled copper wire on Siemens B62152-A7x 2 hole core



LittleDiode supplies new, hard to find or obsolete electronic components and semiconductors all over the world.

With over two million different components listed you are sure to find the part you need.

Feel free to visit us today at our online store:

LittleDiode.com

Looking forward to providing you with the best possible service.