

FEATURES

Dual-mode inclinometer system

Dual-axis, horizontal operation, $\pm 90^\circ$

Single-axis, vertical operation, $\pm 180^\circ$

High accuracy, 0.1°

Digital inclination data, 0.025° resolution

Digital acceleration data, 0.244 mg resolution

$\pm 1.7 \text{ g}$ accelerometer measurement range

Digital temperature sensor output

Digitally controlled bias calibration

Digitally controlled sample rate

Digitally controlled frequency response

Dual alarm settings with rate/threshold limits

Auxiliary digital I/O

Digitally activated self-test

Digitally activated low power mode

SPI-compatible serial interface

Auxiliary 12-bit ADC input and DAC output

Single-supply operation: 3.0 V to 3.6 V

3500 g powered shock survivability

APPLICATIONS

Platform control, stabilization, and alignment

Tilt sensing, inclinometers, leveling

Motion/position measurement

Monitor/alarm devices (security, medical, safety)

Navigation

GENERAL DESCRIPTION

The **ADIS16209** is a high accuracy, digital inclinometer that accommodates both single-axis ($\pm 180^\circ$) and dual-axis ($\pm 90^\circ$) operation. The standard supply voltage (3.3 V) and serial peripheral interface (SPI) enable simple integration into most industrial system designs. A simple internal register structure handles all output data and configuration features. This includes access to the following output data: calibrated acceleration, accurate incline angles, power supply, internal temperature, auxiliary analog and digital input signals, diagnostic error flags, and programmable alarm conditions.

FUNCTIONAL BLOCK DIAGRAM

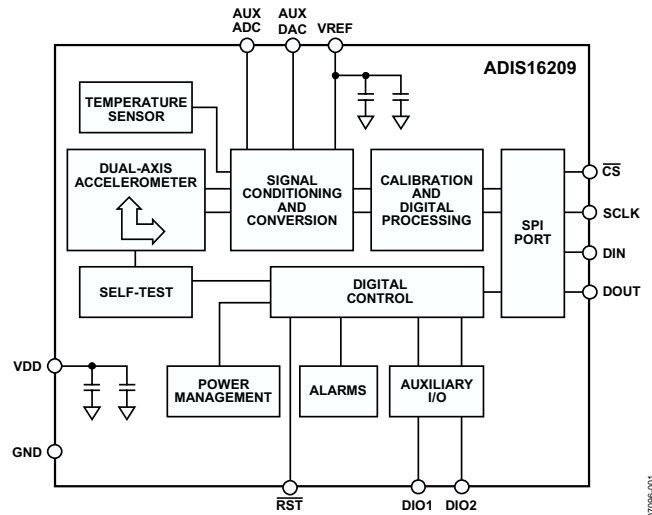

Figure 1.

Configurable operating parameters include sample rate, power management, digital filtering, auxiliary analog and digital output, offset/null adjustment, and self-test for sensor mechanical structure.

The **ADIS16209** is available in a $9.2 \text{ mm} \times 9.2 \text{ mm} \times 3.9 \text{ mm}$ LGA package that operates over a temperature range of -40°C to $+125^\circ\text{C}$. It can be attached using standard RoHS-compliant solder reflow processes.

Rev. C

Information furnished by Analog Devices is believed to be accurate and reliable. However, no responsibility is assumed by Analog Devices for its use, nor for any infringements of patents or other rights of third parties that may result from its use. Specifications subject to change without notice. No license is granted by implication or otherwise under any patent or patent rights of Analog Devices. Trademarks and registered trademarks are the property of their respective owners.

TABLE OF CONTENTS

Features	1	Typical Performance Characteristics	8
Applications	1	Theory of Operation	10
Functional Block Diagram	1	Basic Operation	11
General Description	1	Output Data Registers.....	12
Revision History	2	Operation Control Registers.....	14
Specifications.....	3	Calibration Registers.....	16
Timing Specifications	5	Alarm Registers	16
Timing Diagrams.....	5	Applications Information	18
Absolute Maximum Ratings.....	6	Assembly.....	18
Thermal Resistance	6	Interface Board	18
ESD Caution.....	6	Outline Dimensions	19
Pin Configuration and Function Descriptions.....	7	Ordering Guide	19
Recommended Pad Geometry.....	7		

REVISION HISTORY

7/12—Rev. B to Rev. C

Changes to Endnote 5 in Table 1	4
Changed Digital Input/Output Voltage to GND Maximum Rating from 5.5 V to 5.3 V	6
Added 0x40 to 0x49 and 0x4A Addresses to Table 6	11
Changes to Output Data Registers Section	12
Changes to Digital Filtering Section	14
Changes to Self-Test Section	15
Added Applications Information Section	18
Updated Outline Dimensions	19

8/09—Rev. A to Rev. B

Changes to Features Section.....	1
Changes to Input Low Voltage, V_{INL} , Parameter, Table 1	4
Changes to Figure 18 and Figure 19.....	10
Changes to Table 7, Table 8, and Table 10	12
Updated Outline Dimensions	16
Changes to Ordering Guide	16

7/08—Rev. 0 to Rev. A

Changes to Figure 19	10
Changes to Table 21.....	15

3/08—Revision 0: Initial Version

SPECIFICATIONS

T_A = 25°C, VDD = 3.3 V, tilt = 0°, unless otherwise noted.

Table 1.

Parameter	Conditions	Min	Typ	Max	Unit
HORIZONTAL INCLINE	Each axis				
Input Range			±90		Degrees
Relative Accuracy	±30° from horizon, AVG_CNT = 0x08		±0.1		Degrees
Sensitivity	±30° from horizon		0.025		°/LSB
VERTICAL ROTATION	Rotational plane within ±30° of vertical				
Input Range		-180		+180	Degrees
Relative Accuracy	360° of rotation		±0.25		Degrees
Sensitivity	-40°C to +85°C		0.025		°/LSB
ACCELEROMETER	Each axis				
Input Range ¹	25°C	±1.7			g
Nonlinearity ¹	Percentage of full scale		±0.1	±0.2	%
Alignment Error	X sensor to Y sensor		±0.1		Degrees
Cross Axis Sensitivity			±2		%
Sensitivity	-40°C to +85°C, VDD = 3.0 V to 3.6 V	0.243	0.244	0.245	mg/LSB
ACCELEROMETER NOISE PERFORMANCE					
Output Noise	AVG_CNT = 0x00		1.7		mg rms
Noise Density	AVG_CNT = 0x00		0.19		mg/√Hz rms
ACCELEROMETER FREQUENCY RESPONSE					
Sensor Bandwidth			50		Hz
Sensor Resonant Frequency			5.5		kHz
ACCELEROMETER SELF-TEST STATE ²					
Output Change When Active	At 25°C	706	1343	1973	LSB
TEMPERATURE SENSOR					
Output at 25°C			1278		LSB
Scale Factor			-0.47		°C/LSB
ADC INPUT					
Resolution			12		Bits
Integral Nonlinearity (INL)			±2		LSB
Differential Nonlinearity (DNL)			±1		LSB
Offset Error			±4		LSB
Gain Error			±2		LSB
Input Range		0		2.5	V
Input Capacitance	During acquisition		20		pF
ON-CHIP VOLTAGE REFERENCE					
Accuracy	At 25°C	-10		+10	mV
Reference Temperature Coefficient			±40		ppm/°C
Output Impedance			70		Ω
DAC OUTPUT	5 kΩ/100 pF to GND				
Resolution			12		Bits
Relative Accuracy	For Code 101 to Code 4095		4		LSB
Differential Nonlinearity			1		LSB
Offset Error			±5		mV
Gain Error			±0.5		%
Output Range			0 to 2.5		V
Output Impedance			2		Ω
Output Settling Time			10		μs

Parameter	Conditions	Min	Typ	Max	Unit
LOGIC INPUTS					
Input High Voltage, V_{INH}		2.0			V
Input Low Voltage, V_{INL}				0.8	V
Logic 1 Input High Current, I_{INH}	$V_{IH} = 3.3\text{ V}$		± 0.2	± 10	μA
Logic 0 Input Low Current, I_{INL}	$V_{IL} = 0\text{ V}$				
All Except $\overline{\text{RST}}$			-40	-60	μA
$\overline{\text{RST}}^3$			-1		mA
Input Capacitance, C_{IN}			10		pF
DIGITAL OUTPUTS					
Output High Voltage, V_{OH}	$I_{SOURCE} = 1.6\text{ mA}$	2.4			V
Output Low Voltage, V_{OL}	$I_{SINK} = 1.6\text{ mA}$			0.4	V
SLEEP TIMER					
Timeout Period ⁴		0.5		128	Seconds
START-UP TIME⁵					
Power-On	Time until data is available Fast mode, $\text{SMPL_PRD} \leq 0x07$ Normal mode, $\text{SMPL_PRD} \geq 0x08$		150		ms
Reset Recovery	Fast mode, $\text{SMPL_PRD} \leq 0x07$ Normal mode, $\text{SMPL_PRD} \geq 0x08$		30		ms
Sleep Mode Recovery			70		ms
			2.5		ms
FLASH MEMORY					
Endurance ⁶		20,000			Cycles
Data Retention ⁷	$T_J = 85^\circ\text{C}$	20			Years
CONVERSION RATE SETTING					
		1.04		2731	SPS
POWER SUPPLY					
Operating Voltage Range		3.0	3.3	3.6	V
Power Supply Current	Normal mode, $\text{SMPL_PRD} \geq 0x08$ Fast mode, $\text{SMPL_PRD} \leq 0x07$ Sleep mode, -40°C to $+85^\circ\text{C}$		11	14	mA
			36	42	mA
			140	350	μA

¹ Guaranteed by iMEMS® packaged part testing, design, and/or characterization.

² Self-test response changes as the square of VDD.

³ The RST pin has an internal pull-up.

⁴ Guaranteed by design.

⁵ The times presented in this section represent the time it takes to start producing data in the output registers, after the minimum VDD reaches 3.0 V. They do not represent the settling time of the internal filters.

Note that for the default SENS_AVG and AVG_CNT settings, the typical settling time will be ~1.46 seconds. For faster settling times, reduce the AVG_CNT and SMPL_PRD settings. Note that the trade-off associated with faster settling times will be noise and power.

⁶ Endurance is qualified as per JEDEC Standard 22 Method A117 and measured at -40°C , $+25^\circ\text{C}$, $+85^\circ\text{C}$, and $+125^\circ\text{C}$.

⁷ Retention lifetime equivalent at junction temperature (T_J) 55°C as per JEDEC Standard 22 Method A117. Retention lifetime decreases with junction temperature.

TIMING SPECIFICATIONS

T_A = 25°C, VDD = 3.3 V, tilt = 0°, unless otherwise noted.

Table 2.

Parameter	Description	Min ¹	Typ	Max	Unit
f _{SCLK}	Fast mode, SMPL_PRD ≤ 0x07 (f _s ≥ 546 Hz) ² Normal mode, SMPL_PRD ≥ 0x08 (f _s ≤ 482 Hz) ²	0.01		2.5	MHz
t _{DATARATE}	Chip select period, fast mode, SMPL_PRD ≤ 0x07 (f _s ≥ 546 Hz) ² Chip select period, normal mode, SMPL_PRD ≥ 0x08 (f _s ≤ 482 Hz) ²	40		100	μs
t _{CS}	Chip select to clock edge	48.8			ns
t _{DAV}	Data output valid after SCLK edge			100	ns
t _{DSU}	Data input setup time before SCLK rising edge	24.4			ns
t _{DHD}	Data input hold time after SCLK rising edge	48.8			ns
t _{DF}	Data output fall time		5	12.5	ns
t _{DR}	Data output rise time		5	12.5	ns
t _{SFS}	C _S high after SCLK edge	5			ns

¹ Guaranteed by design, not tested.

² Note that f_s means internal sample rate.

TIMING DIAGRAMS

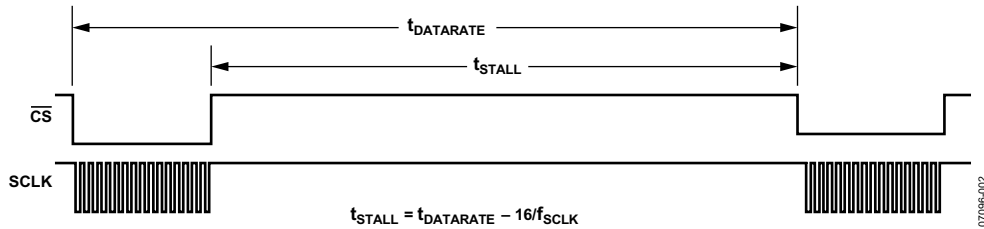

Figure 2. SPI Chip Select Timing

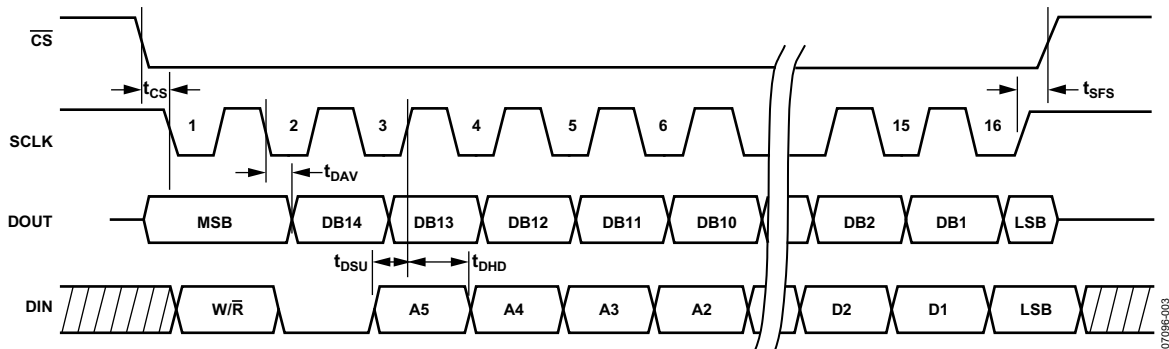

Figure 3. SPI Timing
(Utilizing SPI Settings Typically Identified as Phase = 1, Polarity = 1)

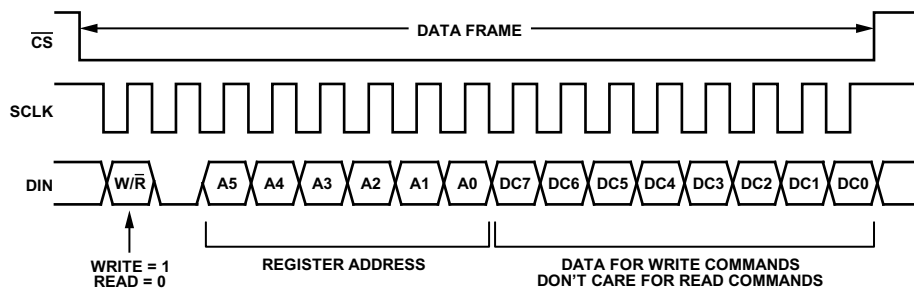

Figure 4. DIN Bit Sequence

ABSOLUTE MAXIMUM RATINGS

Table 3.

Parameter	Rating
Acceleration (Any Axis, Unpowered)	3500 g
Acceleration (Any Axis, Powered)	3500 g
VDD to GND	-0.3 V to +7.0 V
Digital Input/Output Voltage to GND	-0.3 V to +5.3 V
Analog Inputs to GND	-0.3 to VDD + 0.3 V
Analog Inputs to GND	-0.3 to VDD + 0.3 V
Operating Temperature Range	-40°C to +125°C
Storage Temperature Range	-65°C to +150°C

Stresses above those listed under Absolute Maximum Ratings may cause permanent damage to the device. This is a stress rating only; functional operation of the device at these or any other conditions above those indicated in the operational section of this specification is not implied. Exposure to absolute maximum rating conditions for extended periods may affect device reliability.

THERMAL RESISTANCE

Table 4. Package Characteristics

Package Type	θ_{JA}	θ_{JC}	Device Weight
16-Terminal LGA	250°C/W	25°C/W	0.6 g

ESD CAUTION



ESD (electrostatic discharge) sensitive device. Charged devices and circuit boards can discharge without detection. Although this product features patented or proprietary protection circuitry, damage may occur on devices subjected to high energy ESD. Therefore, proper ESD precautions should be taken to avoid performance degradation or loss of functionality.

PIN CONFIGURATION AND FUNCTION DESCRIPTIONS

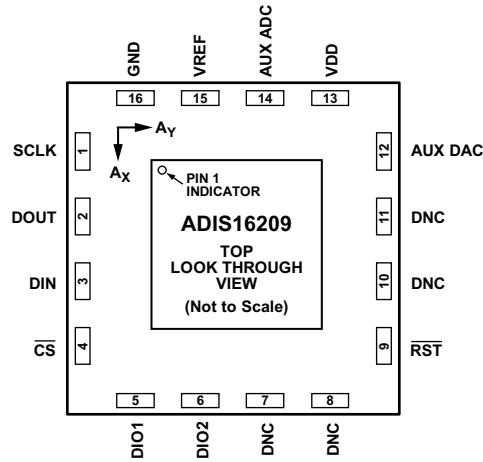

NOTES
 1. DNC = DO NOT CONNECT TO THIS PIN.
 2. THIS IS NOT AN ACTUAL TOP VIEW, BECAUSE THE PINS ARE NOT VISIBLE FROM THE TOP. THIS IS A LAYOUT VIEW THAT REPRESENTS THE PIN CONFIGURATION IF THE PACKAGE IS LOOKED THROUGH FROM THE TOP. THIS CONFIGURATION IS PROVIDED FOR PCB LAYOUT PURPOSES.

Figure 5. Pin Configuration

Table 5. Pin Function Descriptions

Pin No.	Mnemonic	Type ¹	Description
1	SCLK	I	SPI, Serial Clock.
2	DOUT	O	SPI, Data Output.
3	DIN	I	SPI, Data Input.
4	\overline{CS}	I	SPI, Chip Select.
5, 6	DIO1, DIO2	I/O	Digital Input/Output Pins.
7, 8, 10, 11	DNC	N/A	Do not connect to this pin.
9	\overline{RST}	I	Reset, Active Low.
12	AUX DAC	O	Auxiliary DAC Output.
13	VDD	S	Power Supply, 3.3 V.
14	AUX ADC	I	Auxiliary ADC Input.
15	VREF	O	Precision Reference.
16	GND	S	Ground.

¹ S = supply; O = output; I = input.

RECOMMENDED PAD GEOMETRY

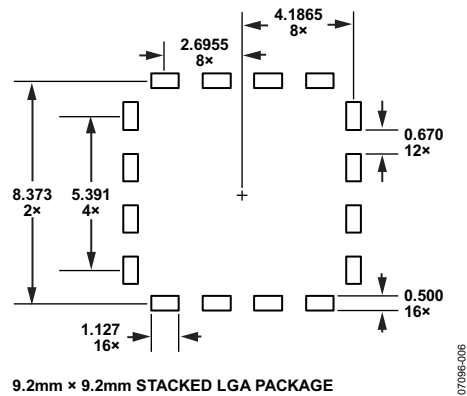

Figure 6. Example of a Pad Layout

TYPICAL PERFORMANCE CHARACTERISTICS

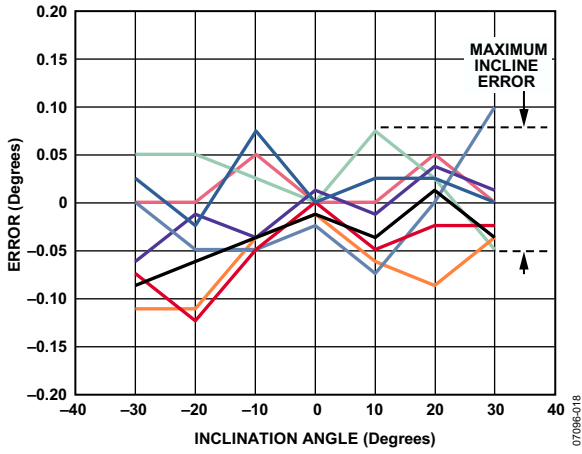

Figure 7. Horizontal Incline Error (Eight Parts), Autonull at Horizontal Position, Stable Temperature, 3.3 V

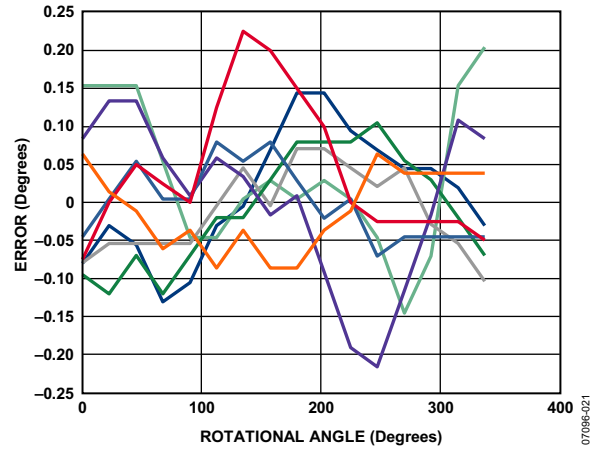

Figure 10. Vertical Mode Rotational Error (Eight Parts), 25°C, 3.3 V

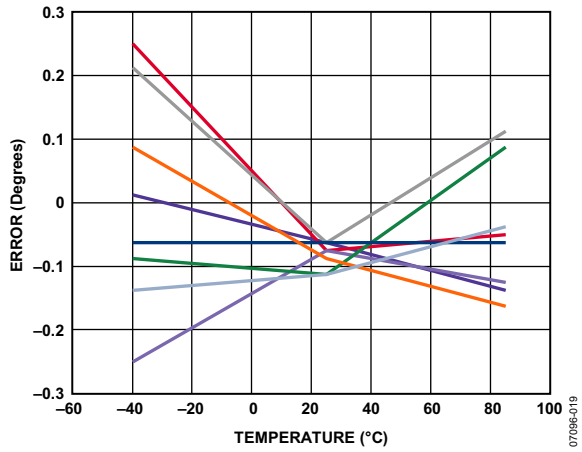

Figure 8. Maximum Incline Error Over a $\pm 30^\circ$ Incline Range (Eight Parts) Over Temperature, Autonull at Horizontal Position, 25°C, 3.3 V

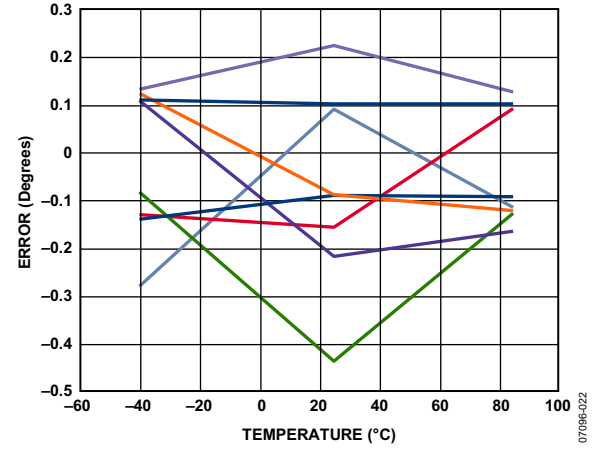

Figure 11. Vertical Mode Error (Eight Parts) vs. Temperature, 0° to 360°, 3.3 V

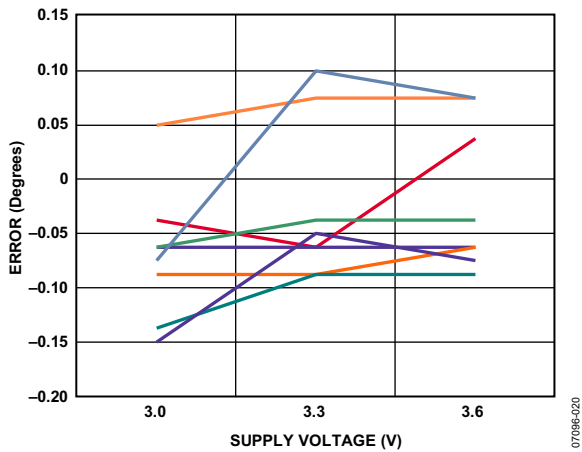

Figure 9. Maximum Incline Error Over a $\pm 30^\circ$ Incline Range (Eight Parts) Over Supply Voltage, Autonull Horizontal Position, 25°C, 3.3 V

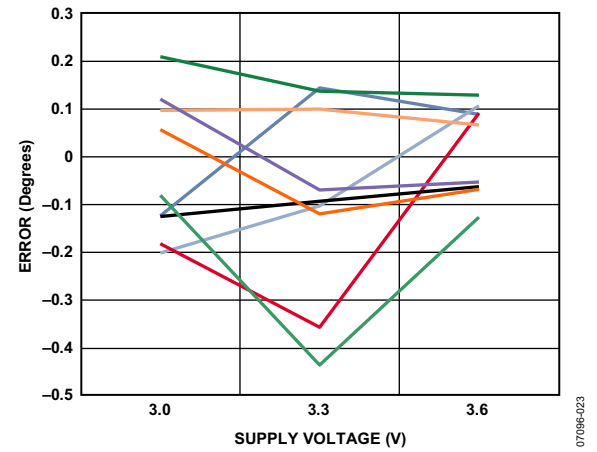

Figure 12. Vertical Mode Error (Eight Parts) vs. Supply Voltage, 0° to 360°, 25°C

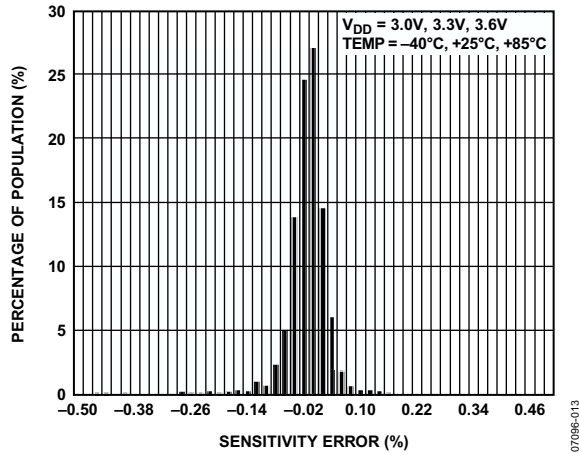

Figure 13. Accelerometer Output Sensitivity Error Distribution

07096-013

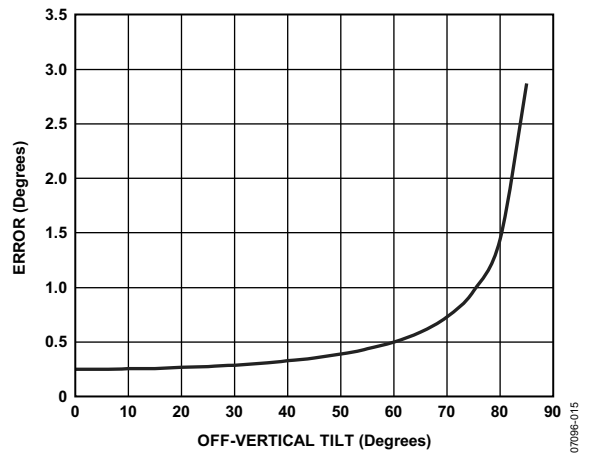

Figure 15. Error vs. Off-Vertical Tilt, 25°C, 3.3 V

07096-015

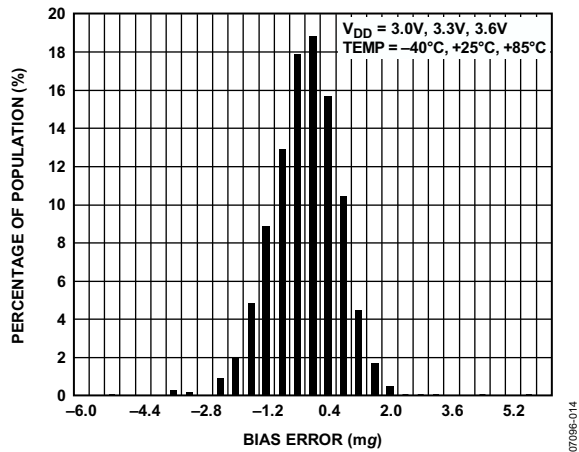

Figure 14. Accelerometer Output Bias Error Distribution

07096-014

THEORY OF OPERATION

The ADIS16209 tilt sensing system uses gravity as its only stimulus, and a MEMS accelerometer as its sensing element. MEMS accelerometers typically employ a tiny, spring-loaded structure that is interlaced with a fixed pick-off finger structure. The spring constant of the floating structure determines how far it moves when subjected to a force. This structure responds to dynamic forces associated with acceleration and to static forces, such as gravity.

Figure 16 and Figure 17 illustrate how the accelerometer responds to gravity, according to its orientation, with respect to gravity. Figure 16 displays the configuration for the incline angle outputs, and Figure 17 displays the configuration used for the rotational angle position. This configuration provides greater measurement range than a single axis. The ADIS16209 incorporates the signal processing circuit that converts acceleration into an incline angle, and it corrects for several known error sources that would otherwise degrade the accuracy level.

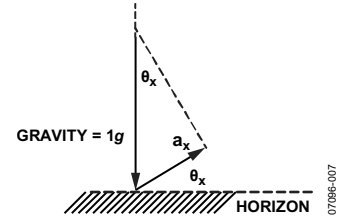

Figure 16. Single-Axis Tilt Theory Diagram

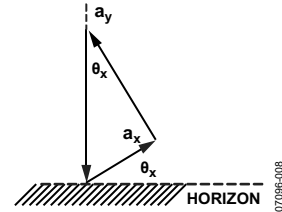

Figure 17. Dual-Axis Tilt Theory Diagram

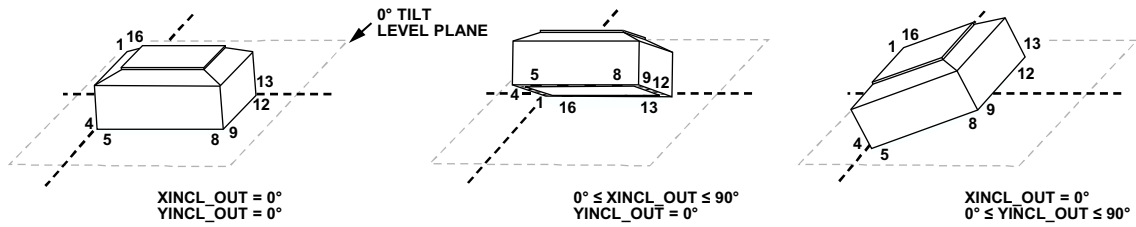
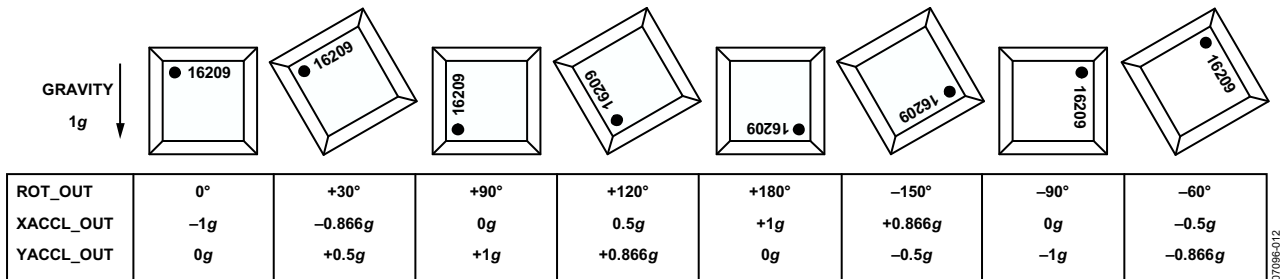

Figure 18. Horizontal Incline Angle Orientation



NOTES
 1. ROT_OUT = 180° IS 1 LSB DIFFERENT THAN ROT_OUT = -179.975°.

Figure 19. Vertical Angle Orientation

BASIC OPERATION

The ADIS16209 requires only power/ground and SPI connections. The SPI is simple to hook up and is supported by many common digital hardware platforms. Figure 20 provides a simple hook-up diagram, while Table 2, Figure 2, and Figure 3 provide timing and bit assignments. Figure 4 provides the bit sequence for accessing the register memory structure. Each function within the ADIS16209 has its own 16-bit, 2-byte register. Each byte has its own unique 6-bit address. Note that all 16 SCLK cycles are required for the DIN bit sequence to configure the output for the next data frame. The ADIS16209 supports full duplex mode operation. Table 6 provides the entire user register map for the ADIS16209. For each register, the lower bytes address is given. For those registers that have two bytes, the upper bytes address is simply the lower bytes address, incremented by 0x01.

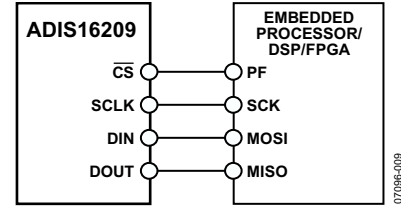

Figure 20. Typical SPI Hook-Up

Many of the configuration registers have also been assigned mirror locations in the flash memory, which effectively provide them with a backup storage function. To ensure the backup of these registers, the COMMAND register provides an initiation bit for manual flash updates. The ENDURANCE register provides a running count of these events.

Table 6. User Register Map

Name	R/W	Flash Backup	Address	Size (Bytes)	Function	Reference
ENDURANCE	R	Yes	0x00	2	Diagnostics, flash write counter (16-bit binary)	
SUPPLY_OUT	R	No	0x02	2	Output, power supply	Table 18
XACCL_OUT	R	No	0x04	2	Output, x-axis acceleration	Table 8
YACCL_OUT	R	No	0x06	2	Output, y-axis acceleration	Table 9
AUX_ADC	R	No	0x08	2	Output, auxiliary ADC	Table 20
TEMP_OUT	R	No	0x0A	2	Output, temperature	Table 16
XINCL_OUT	R	No	0x0C	2	Output, $\pm 90^\circ$ x-axis inclination	Table 11
YINCL_OUT	R	No	0x0E	2	Output, $\pm 90^\circ$ y-axis inclination	Table 12
ROT_OUT	R	No	0x10	2	Output, $\pm 180^\circ$ vertical rotational position	Table 14
XACCL_NULL	R/W	Yes	0x12	2	Calibration, x-axis acceleration offset null	Table 30
YACCL_NULL	R/W	Yes	0x14	2	Calibration, y-axis acceleration offset null	Table 30
XINCL_NULL	R/W	Yes	0x16	2	Calibration, x-axis inclination offset null	Table 31
YINCL_NULL	R/W	Yes	0x18	2	Calibration, y-axis inclination offset null	Table 31
ROT_NULL	R/W	Yes	0x1A	2	Calibration, vertical rotation offset null	Table 31
			0x1C to 0x1F	4	Reserved, do not write to these locations	
ALM_MAG1	R/W	Yes	0x20	2	Alarm 1, amplitude threshold	Table 32
ALM_MAG2	R/W	Yes	0x22	2	Alarm 2, amplitude threshold	Table 32
ALM_SMPL1	R/W	Yes	0x24	2	Alarm 1, sample period	Table 33
ALM_SMPL2	R/W	Yes	0x26	2	Alarm 2, sample period	Table 33
ALM_CTRL	R/W	Yes	0x28	2	Alarm, source control register	Table 34
		No	0x2A to 0x2F	6	Reserved	
AUX_DAC	R/W	No	0x30	2	Auxiliary DAC data	Table 28
GPIO_CTRL	R/W	No	0x32	2	Operation, digital I/O configuration and data	Table 27
MSC_CTRL	R/W	No	0x34	2	Operation, data-ready and self-test control	Table 26
SMPL_PRD	R/W	Yes	0x36	2	Operation, sample rate configuration	Table 22
AVG_CNT	R/W	Yes	0x38	2	Operation, filter configuration	Table 24
SLP_CNT	W	Yes	0x3A	2	Operation, sleep mode control	Table 23
STATUS	R	No	0x3C	2	Diagnostics, system status register	Table 35
COMMAND	W	No	0x3E	2	Operation, system command register	Table 29
		No	0x40 to 0x49	10	Reserved	
PROD_ID	R	Yes	0x4A	2	Product identification = 0x3F51	N/A

OUTPUT DATA REGISTERS

Table 7 provides the data configuration for each output data register in the ADIS16209. Starting with the MSB of the upper byte, each output data register has the following bit sequence: new data (ND) flag, error/alarm (EA) flag, followed by 14 data bits. The data bits are LSB justified, and in the case of the 12-bit data formats, the remaining two bits are not used. The ND flag indicates that unread data resides in the output data registers. This flag clears and returns to 0 during an output register read sequence. It returns to 1 after the next internal sample update cycle completes. The EA flag indicates an error condition. The STATUS register contains all of the error flags and provides the ability to investigate the root cause.

Table 7. Output Data Register Formats

Register	Bits	Format	Scale ¹
SUPPLY_OUT	14	Binary, 3.3 V = 0x2A3D	0.30518 mV
XACCL_OUT	14	Twos complement	0.24414 mg
YACCL_OUT	14	Twos complement	0.24414 mg
AUX_ADC	12	Binary, 2 V = 0x0CCC	0.6105 mV
TEMP_OUT	12	Binary, 25°C = 0x04FE	-0.47°C
XINCL_OUT ²	14	Twos complement	0.025°
YINCL_OUT ²	14	Twos complement	0.025°
ROT_OUT ³	14	Twos complement	0.025°

¹ Scale denotes quantity per LSB.

² Range is -90° to +90°.

³ Range is -179.975° to +180°.

Accelerometers

The accelerometers respond to both static (gravity) and dynamic acceleration using the polarity shown in Figure 21.

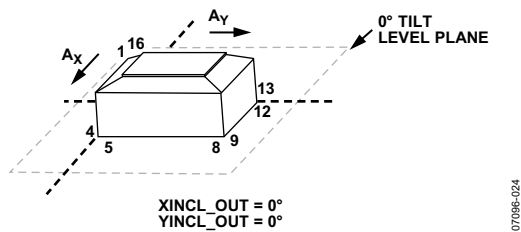

Figure 21. Accelerometer Polarity

The XACCL_OUT (see Table 8) and YACCL_OUT (see Table 9) registers provide access to acceleration data for each axis. For example, set DIN = 0x0400 to request data from the x-axis register on the next 16-bit SPI sequence. After reading the contents of one of these registers, mask off the upper two bits, convert the remaining 14-bit, twos complement number into a decimal equivalent, and then multiply that number by 0.025 to convert the measurement into units of angle (mg). Table 10 provides several examples of this data format.

Table 8. XACCL_OUT (Base Address = 0x04), Read Only

Bits	Description
15	New data bit = 1, when register contains un-read data
14	Error/alarm = 1, when STATUS ≠ 0x0000
[13:0]	x-axis accelerometer output data, twos complement, 1 LSB = 0.24414 mg, 0 g = 0x0000

Table 9. YACCL_OUT (Base Address = 0x06), Read Only

Bits	Description
15	New data bit = 1, when register contains un-read data
14	Error/alarm = 1, when STATUS ≠ 0x0000
[13:0]	y-axis accelerometer output data, twos complement, 1 LSB = 0.24414 mg, 0 g = 0x0000

Table 10. Accelerometer Data Format Examples

Acceleration (g)	Decimal	Hex	Binary
+1.7	+6,963	0x1B33	xx01 1011 0011 0011
+1.0	+4,096	0x1000	xx01 0000 0000 0000
+0.00048828	+2	0x0002	xx00 0000 0000 0010
+0.00024414	+1	0x0001	xx00 0000 0000 0001
0	0	0x0000	xx00 0000 0000 0000
-0.00024414	-1	0x3FFF	xx11 1111 1111 1111
-0.00048828	-2	0xFFFE	xx11 1111 1111 1110
-1.0	-4096	0x3000	xx11 0000 0000 0000
-1.7	-27,853	0xE4CD	xx10 0100 1100 1101

Horizontal Incline Angle

The XINCL_OUT (see Table 11) and YINCL_OUT (see Table 12) registers provide access to acceleration data for each axis. For example, set DIN = 0x0400 to request data from the x-axis register on the next 16-bit SPI sequence. After reading the contents of one of these registers, mask off the upper two bits, convert the remaining 14-bit, twos complement number into a decimal equivalent, and then multiply that number by 0.025 to convert the measurement into units of angle (°).

Table 13 provides several examples of this data format.

Table 11. XINCL_OUT (Base Address = 0x0C), Read Only

Bits	Description
15	New data bit = 1, when register contains un-read data
14	Error/alarm = 1, when STATUS ≠ 0x0000
[13:0]	x-axis inclinometer output data, twos complement, 0° = 0x0000, 1 LSB = 0.025°/LSB, ±90° range

Table 12. YINCL_OUT (Base Address = 0x0E), Read Only

Bits	Description
15	New data bit = 1, when register contains un-read data
14	Error/alarm = 1, when STATUS ≠ 0x0000
[13:0]	y-axis inclinometer output data, twos complement, 0° = 0x0000, 1 LSB = 0.025°/LSB, ±90° range

Table 13. Horizontal Incline Angle Data Format Examples

Orientation	Decimal	Hex	Binary
+90° – 0.025°	+3,599	0x0E0F	0000 1110 0000 1111
+0.05°	+2	0x0002	xx00 0000 0000 0010
+0.025°	+1	0x0001	xx00 0000 0000 0001
0°	0	0x0000	xx00 0000 0000 0000
–0.025°	–1	0x3FFF	xx11 1111 1111 1111
–0.05°	–2	0x3FFE	xx11 1111 1111 1110
–90°	–3,600	0x31F1	xx11 0001 1111 0001

Vertical Incline Angle

The ROT_OUT register (see Table 14) provides access to incline angle data for each axis. For example, set DIN = 0x1000 to request data from this register on the next 16-bit SPI sequence. After reading the contents of one of these registers, mask off the upper two bits, convert the remaining 14-bit, twos complement number into a decimal equivalent, and then multiply that number by 0.025 to convert the measurement into units of angle (°).

Table 15 provides several examples of this data format.

Table 14. ROT_OUT (Base Address = 0x10), Read Only

Bits	Description
15	New data bit = 1, when register contains un-read data
14	Error/alarm = 1, when STATUS ≠ 0x0000
[13:0]	Vertical inclinometer output data, twos complement, 0° = 0x0000, 1 LSB = 0.025°/LSB, ±180° range

Table 15. Vertical Incline Angle Data Format Examples

Orientation	Decimal	Hex	Binary
+180° – 0.025°	+7,199	0x1C1F	xx01 1100 0001 1111
+0.05°	+2	0x0002	xx00 0000 0000 0010
+0.025°	+1	0x0001	xx00 0000 0000 0001
0°	0	0x0000	xx00 0000 0000 0000
–0.025°	–1	0x3FFF	xx11 1111 1111 1111
–0.05°	–2	0x3FFE	xx11 1111 1111 1110
–180°	–7,200	0x23E0	xx10 0011 1110 0000

Internal Temperature

The TEMP_OUT register (see Table 16) provides access to an internal temperature measurement. Set DIN = 0x0A00 to request the contents of this register. Mask off the upper four bits, then convert the remaining 12-bit binary number into a decimal equivalent, subtract 1278, multiply it by –0.47 and add 25 to convert this number into °C. See Table 17 for examples of this format. Note that this internal temperature measurement provides an indicator of condition changes, not an absolute measurement of conditions outside of the package.

Table 16. TEMP_OUT (Base Address = 0x0A), Read Only

Bits	Description
[15:0]	Internal temperature data, binary format, sensitivity = –0.47°/LSB, 25°C = 1278 LSB = 0x04FE

Table 17. Internal Temperature Data Format Examples

Temperature (°C)	LSB	Hex	Binary
+125	1065	0x0429	xxxx 0100 0010 1001
25 + 0.47	1277	0x04FD	xxxx 0100 1111 1101
+25	1278	0x04FE	xxxx 0100 1111 1110
25 – 0.047	1279	0x04FF	xxxx 0100 1111 1111
0	1331	0x0533	xxxx 0101 0011 0011
–40	1416	0x0588	xxxx 0101 1000 1000

Power Supply

The SUPPLY_OUT register (see Table 18) provides a digital measurement for the supply voltage on the VDD pins (see Figure 5). Set DIN = 0x0200 to request the contents of this register. See Table 19 for examples of this data format.

Table 18. SUPPLY_OUT (Base Address = 0x02), Read Only

Bits	Description
15	New data bit = 1, when register contains un-read data
14	Error/alarm = 1, when STATUS ≠ 0x0000
[15:0]	Power supply measurement data, binary format, 1 LSB = 0.00030518 V, 0 V = 0x0000

Table 19. Power Supply Data Format Examples

Supply Level (V)	LSB	Hex	Binary
3.6	11,796	0x2E14	xx10 1110 0001 0100
3.3 + 0.00030518	10,814	0x2A3E	xx10 1010 0011 1110
3.3	10,813	0x2A3D	xx10 1010 0011 1101
3.3 – 0.00030518	10,812	0x2A3C	xx10 1010 0011 1100
3.0	9,830	0x2666	xx10 0110 0110 0110

Auxiliary ADC

The AUX_ADC register (see Table 20) provides a digital measurement for the AUX_ADC input pin (see Figure 5). Set DIN = 0x0800 to request the contents of this register. See Table 21 for examples of this data format.

Table 20. AUX_ADC (Base Address = 0x08), Read Only

Bits	Description
15	New data bit = 1, when register contains un-read data
14	Error/alarm = 1, when STATUS ≠ 0x0000
[13:12]	Not used
[15:0]	Auxiliary ADC data, binary format, 1 LSB = 0.0006105 V, 0 V = 0x0000

Table 21. Auxiliary ADC Data Format Examples

Supply Level (V)	LSB	Hex	Binary
2.5	4095	0xFFF	xxxx 1111 1111 1111
0.001221	2	0x002	xxxx 0000 0000 0010
0.0006105	1	0x001	xxxx 0000 0000 0001
0	0	0x000	xxxx 0000 0000 0000

OPERATION CONTROL REGISTERS

Internal Sample Rate

The SMPL_PRD register controls the ADIS16209 internal sample rate and has two parts: a selectable time base and a multiplier. The following relationship produces the sample rate:

$$t_s = t_B \times N_S + 122.07 \mu\text{s}$$

Table 22. SMPL_PRD Bit Descriptions

Bit	Description	(Default = 0x0014)
15:8	Not used	
7	Time base (t_B): 0 = 244.14 μs , 1 = 7.568 ms	
6:0	Increment setting (N_S)	

An example calculation of the default sample period follows:

$$\text{SMPL_PRD} = 0x01, B_7 - B_0 = 00000001$$

$$B_7 = 0 \rightarrow t_B = 244.14 \mu\text{s}, B_6 \dots B_0 = 00000001 \rightarrow N_S = 1$$

$$t_s = t_B \times N_S + 122.07 \mu\text{s} = 244.14 \times 1 + 122.07 = 366.21 \mu\text{s}$$

$$f_s = 1/t_s = 2731 \text{ SPS}$$

The sample rate setting has a direct impact on the SPI data rate capability. For sample rates ≥ 546 SPS, the SPI SCLK can run at a rate up to 2.5 MHz. For sample rates < 546 SPS, the SPI SCLK can run at a rate up to 1 MHz. The sample rate setting also affects power dissipation. When the sample rate is set to < 546 SPS, power dissipation typically reduces by a factor of 68%. The two different modes of operation offer a system-level trade-off between performance (sample rate, serial transfer rate) and power dissipation.

Power Management

In addition to offering two different performance modes for power optimization, the ADIS16209 offers a programmable shutdown period that the SLP_CNT register controls.

Table 23. SLP_CNT Bit Descriptions

Bit	Description	(Default = 0x0000)
15:8	Not used	
7:0	Data bits, 0.5 seconds/LSB	

For example, writing 0x08 to the SLP_CNT register places the ADIS16209 into sleep mode for 4 sec. The only way to stop this process is to remove power or reset the device.

Digital Filtering

The AVG_CNT register controls the moving average digital filter, which determines the size of the moving average filter in eight power-of-two step sizes (that is, $2^M = 1, 2, 4, 16, 32, 64, 128,$ and 256). Filter setup requires one simple step: write the appropriate M factor to the assigned bits in the AVG_CNT register. Note that the default settings for AVG_CNT and SMPL_PRD provide the best accuracy but require approximately 1.46 seconds to settle.

Table 24. AVG_CNT Bit Descriptions

Bit	Description	(Default = 0x0008)
15:4	Not used	
3:0	Power-of-two step size, maximum binary value = 1000	

The following equation offers a frequency response relationship for this filter:

$$H_A(f) = \frac{\sin(\pi \times N \times f \times t_s)}{N \times \sin(\pi \times f \times t_s)}$$

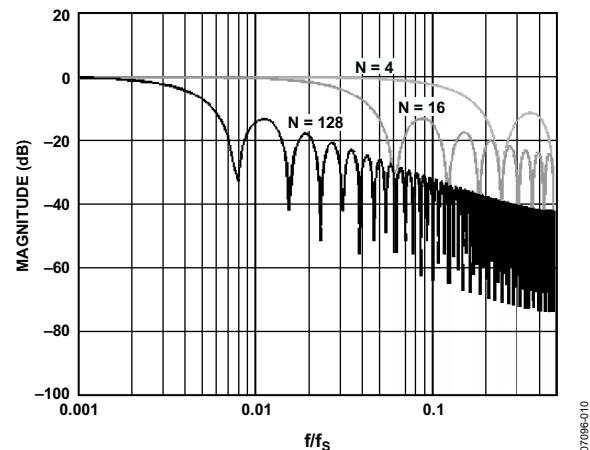

Figure 22. Frequency Response—Moving Average Filter

Digital I/O Lines

The ADIS16209 provides two general-purpose, digital input/output lines that have several configuration options.

Table 25. Digital I/O Line Configuration Registers

Function	Priority	Register
Data-Ready I/O Indicator	1	MSC_CTRL
Alarm Indicator	2	ALM_CTRL
General-Purpose I/O Configuration	3	GPIO_CTRL
General-Purpose I/O Line Communication		GPIO_CTRL

Data-Ready I/O Indicator

The MSC_CTRL register provides controls for a data-ready function. For example, writing 0x05 to this register enables this function and establishes DIO2 as an active-low, data-ready line. The duty cycle is 25% ($\pm 10\%$ tolerance).

Table 26. MSC_CTRL Bit Descriptions

Bit	Description	(Default = 0x0000)
15:11	Not used	
10	Self-test at power-on: 1 = disabled, 0 = enabled	
9	Not used	
8	Self-test enable (temporary, bit is volatile): 1 = enabled, 0 = disabled	
7:3	Not used	
2	Data-ready enable: 1 = enabled, 0 = disabled	
1	Data-ready polarity: 1 = active high, 0 = active low	
0	Data-ready line select: 1 = DIO2, 0 = DIO1	

Self-Test

Self-test exercises the mechanical structure of the sensor and provides a simple method for verifying the operation of the entire sensor signal conditioning circuit. There are two different self-test options: startup and manual. If either of these self-tests results in a failure, the self-test error flag, located in the STATUS register, sets to 1. Set MSC_CTRL[8] = 1 to start the manual self-test sequence, which triggers a single, self-test pulse, which creates a response on the output of the accelerometers, when the device is operating properly. The sensor passes the test when its response is within the expected levels for the device. Once the test finishes, MSC_CTRL[8] resets itself to zero, the result loads into STATUS[5] and the sensor resumes normal operation. Do not attempt to change SMPL_PRD and AVG_CNT while the device is going through the self-test routine. See Table 26 for more information on the MSC_CTRL register.

General-Purpose I/O

The GPIO_CTRL register controls the direction and data of the general-purpose digital lines, DIO1 and DIO2. For example, writing a 0x02 to the GPIO_CTRL register sets DIO2 as an output line and DIO1 as an input line. Reading the data bits in GPIO_CTRL reveals the line logic level.

Table 27. GPIO_CTRL Bit Descriptions

Bit	Description	(Default = 0x0000)
15:10	Not used	
9	General-Purpose I/O Line 2 data	
8	General-Purpose I/O Line 1 data	
7:2	Not used	
1	General-Purpose I/O Line 2, data direction control: 1 = output, 0 = input	
0	General-Purpose I/O Line 1, data direction control: 1 = output, 0 = input	

Auxiliary DAC

The auxiliary DAC provides a 12-bit level adjustment function. The AUX_DAC register controls the operation of the auxiliary DAC function, which is useful for systems that require analog level controls. It offers a rail-to-rail buffered output that has a range of 0 V to 2.5 V. The DAC can drive its output to within 5 mV of the ground reference when it is not sinking current. As the output approaches ground, the linearity begins to degrade (100 LSB beginning point). As the sink current increases, the nonlinear range increases. The DAC output latch function, contained in the COMMAND register, provides continuous operation while writing to each byte of this register. The contents of this register are volatile, which means that the desired output level must be set after every reset and power cycle event.

Table 28. AUX_DAC Bit Descriptions

Bit	Description	(Default = 0x0000)
15:12	Not used	
11:0	Data bits, scale factor = 0.6105 mV/code Offset binary format, 0 V = 0 codes	

Global Commands

The COMMAND register provides initiation bits for several commands that simplify many common operations. Writing a 1 to the assigned COMMAND bit exercises its function.

Table 29. COMMAND Bit Descriptions

Bit	Description	(Default = 0x0000)
15:8	Not used	
7	Software reset	
6:5	Not used	
4	Clear status register (reset all bits to 0)	
3	Flash update; backs up all registers, see Table 6	
2	DAC data latch	
1	Factory calibration restore	
0	Autonull	

The software reset command restarts the internal processor, which loads all registers with the contents in their flash memory locations.

The flash update copies the contents of all the flash backup registers into their assigned, nonvolatile flash memory locations. This process takes approximately 50 ms and requires a power supply that is within the specified operating range. After waiting the appropriate time for the flash update to complete, verify successful completion by reading the STATUS register (if successful, the flash update error is 0). If the flash update was not successful, reading this error bit accomplishes two things: it alerts the system processor to try again, and it clears the error flag, which is required for flash memory access.

The DAC data latch command loads the contents of AUX_DAC into the DAC latches. Because the AUX_DAC contents must be updated one byte at a time, this command ensures a stable DAC output voltage during updates.

The autonull command provides a simple method for removing offset from the sensor outputs. This command takes the contents of the output data registers and loads the equal but opposite number into the offset calibration registers. The accuracy of this operation depends on zero force, zero motion, and optimal noise management during the measurement (see the Digital Filtering section). The factory calibration restore sets the offset null registers (XACCL_NULL, for example) back to their default values.

CALIBRATION REGISTERS

The ADIS16209 incorporates an extensive factory calibration and provides precision acceleration, incline, and rotational position data. For systems that require on-site calibration, user-programmable offset adjustment registers are available.

Table 30 provides the bit assignments for the following user-programmable calibration registers: XACCL_NULL and YACCL_NULL. Table 31 provides the bit assignments for the following user-programmable calibration registers: XINCL_NULL, YINCL_NULL, and ROT_NULL.

Table 30. Acceleration Offset Register Bit Designations

Bit	Description (Default = 0x0000)
15:14	Not used
13:0	Data bits, twos complement, sensitivity = 0.24414 mg/LSB

Table 31. Incline/Rotation Offset Register Bit Designations

Bit	Description (Default = 0x0000)
15:14	Not used
13:0	Data bits, twos complement, sensitivity = 0.025°/LSB

ALARM REGISTERS

The alarm function provides monitoring for two independent conditions. The ALM_CTRL register provides control inputs for data source, data filtering (prior to comparison), static/dynamic, and output indicator configurations. The ALM_MAGx registers establish the trigger threshold and polarity configurations. The ALM_SMPLx registers provide the numbers of samples to use in the dynamic rate-of-change configuration. The rate-of-change calculation is

$$Y_c = \frac{1}{N_{DS}} \sum_{n=1}^{N_{DS}} y(n+1) - y(n) \Rightarrow Alarm \Rightarrow is Y_c > or < M_c ?$$

where:

N_{DS} is the number of samples in ALM_SMPLx.

$y(n)$ is the sampled output data.

M_c is the magnitude for comparison in ALM_MAGx.

> or < is determined by the MSB in ALM_MAGx.

Table 32. ALM_MAG1/ALM_MAG2 Bit Designations

Bit	Description (Default = 0x0000)
15	Comparison polarity: 1 = greater than, 0 = less than
14	Not used
13:0	Data bits, matches format of trigger source selection

Table 33. ALM_SMPL1/ALM_SMPL2 Bit Designations

Bit	Description (Default = 0x0001)
15:8	Not used
7:0	Data bits: number of samples (both 0x00 and 0x01 = 1)

Table 34. ALM_CTRL Bit Descriptions

Bit	Value	Description (Default = 0x0000)
15:12		Trigger source, Alarm 2
	0000	Disabled
	0001	Power supply
	0010	X-acceleration
	0011	Y-acceleration
	0100	Auxiliary ADC
	0101	Temperature sensor
	0110	X-axis incline angle
	0111	Y-axis incline angle
	1000	Rotational position
11:8		Trigger source, Alarm 1, same as Bits[15:12]
7		Not used
6		Alarm 2 rate-of-change control: 1 = enabled
5		Alarm 1 rate-of-change control: 1 = enabled
4		Alarm 2 filter: 1 = filtered data, 0 = no filter ¹
3		Alarm 1 filter: 1 = filtered data, 0 = no filter ¹
2		Alarm indicator, using DIO1/DIO2: 1 = enabled
1		Alarm indicator polarity: 1 = active high
0		Alarm indicator line select: 1 = DIO2, 0 = DIO1

¹ Incline and vertical angles always use filtered data in this comparison.

Status

The STATUS register provides a series of error flags that provide indicator functions for common system-level issues. All of the flags clear (set to 0) after each STATUS register read cycle. If an error condition remains, the error flag returns to 1 during the next sample cycle.

Table 35. STATUS Bit Descriptions

Bit	Description	(Default = 0x0000)
15:10	Not used	
9	Alarm 2 status: 1 = active, 0 = inactive	
8	Alarm 1 status: 1 = active, 0 = inactive	
7:6	Not used	
5	Self-test diagnostic error flag: 1 = error condition, 0 = normal operation	
4	Not used	
3	SPI communications failure: 1 = error condition, 0 = normal operation	
2	Flash update failed: 1 = error condition, 0 = normal operation	
1	Power supply greater than 3.625 V: 1 > 3.625 V, 0 ≤ 3.625 V (normal)	
0	Power supply less than 2.975 V: 1 < 2.975 V, 0 ≥ 2.975 V (normal)	

APPLICATIONS INFORMATION

ASSEMBLY

When developing a process flow for installing [ADIS16209](#) devices on PCBs, see the JEDEC standard document J-STD-020C for reflow temperature profile and processing information. The [ADIS16209](#) can use the Sn-Pb eutectic process and the Pb-free eutectic process from this standard. See JEDEC J-STD-033 for moisture sensitivity level (MSL) handling requirements. The MSL rating for these devices is marked on the antistatic bags, which protect these devices from ESD during shipping and handling. Prior to assembly, review the process flow for information about introducing shock levels that exceed the absolute maximum ratings for the [ADIS16209](#). PCB separation and ultrasonic cleaning processes can introduce high levels of shock and can damage the MEMS element. Bowing or flexing the PCB after solder reflow can also place large peeling stress on the pad structure and can damage the device. If this is unavoidable, consider using an underfill material to help distribute these forces across the bottom of the package.

INTERFACE BOARD

The ADIS16209/PCBZ provides the [ADIS16209](#) function on a 1.2 inch × 1.3 inch printed circuit board (PCB), which simplifies the connection to an existing processor system. The four mounting holes accommodate either M2 (2 mm) or Type 2-56 machine screws. These boards are made of IS410 material and are 0.063 inches thick. The second level assembly uses a SAC305-compatible solder composition (Pb-free), which has a presolder reflow thickness of approximately 0.005 inches. The pad pattern on the ADIS16209/PCBZ matches that shown in Figure 24. J1 and J2 are dual-row, 2 mm (pitch) connectors that work with a number of ribbon cable systems, including 3M Part Number 152212-0100-GB (ribbon-crimp connector) and 3M Part Number 3625/12 (ribbon cable).

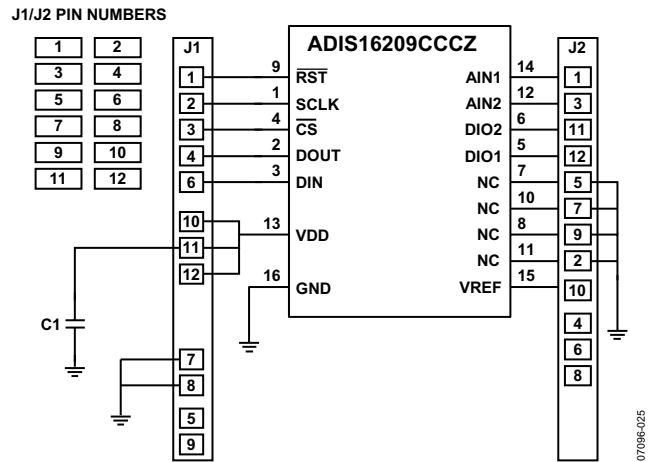

Figure 23. Electrical Schematic

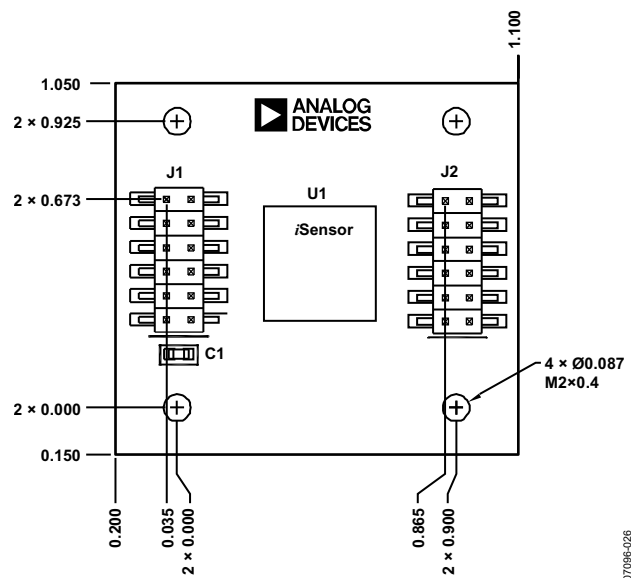
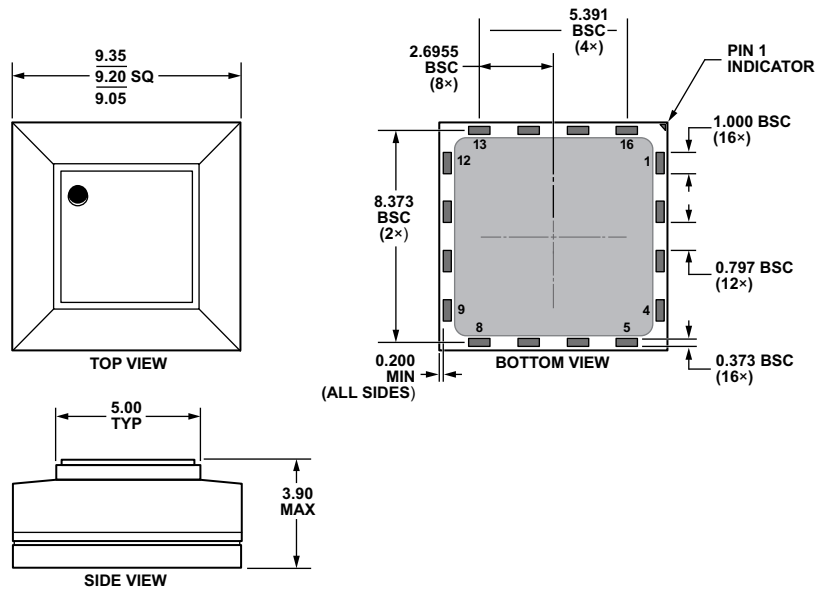

Figure 24. PCB Assembly View and Dimensions

OUTLINE DIMENSIONS



121409-C

Figure 25. 16-Terminal Stacked Land Grid Array [LGA]
(CC-16-2)
Dimensions shown in millimeters

ORDERING GUIDE

Model ¹	Temperature Range	Package Description	Package Option
ADIS16209CCCZ	-40°C to +125°C	16-Terminal Stacked Land Grid Array [LGA]	CC-16-2
ADIS16209PCBZ		Evaluation Board	

¹ Z = RoHS Compliant Part.

NOTES



LittleDiode supplies new, hard to find or obsolete electronic components and semiconductors all over the world.

With over two million different components listed you are sure to find the part you need.

Feel free to visit us today at our online store:

LittleDiode.com

Looking forward to providing you with the best possible service.