

General Description

The ADS4616A4A are two-bank Synchronous DRAMs organized as 524,288 words x 16 bits x 2 banks,

Synchronous design allows precise cycle control with the use of system clock I/O transactions are possible on every clock cycle.

Range of operating frequencies, programmable burst length and programmable latencies allow the same device to be useful for a variety of high bandwidth high performance memory system applications

Features

- Single 3.3V +/- 0.3V power supply
- MRS Cycle with address key programs
 - CAS Latency (2 & 3)
 - Burst Length (1,2,4,8, & full page)
 - Burst Type (sequential & Interleave)
- 2 banks operation
- All inputs are sampled at the positive edge of the system clock
- Burst Read single write operation
- Auto & Self refresh
- 4096 refresh cycle
- DQM for masking
- Package:50-pins 400 mil TSOP-Type II

Ordering Information.

Part No.	Frequency	Interface	Package
ADS4616A4A-5	200Mhz	LVTTL	400mil 50pin TSOPII
ADS4616A4A -6	166Mhz	LVTTL	400mil 50pin TSOPII
ADS4616A4A -7	143Mhz	LVTTL	400mil 50pin TSOPII

Pin Assignment

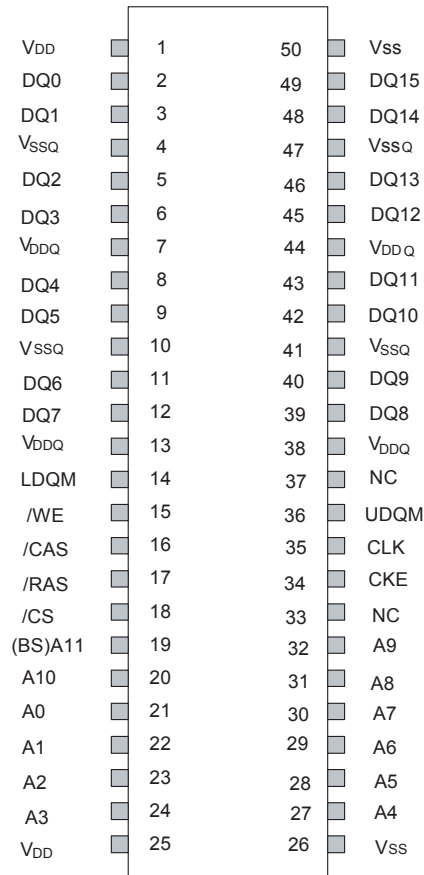

50-pin plastic TSOP II 400 mil

Pin Description

PIN	NAME	FUNCTION
CLK	System Clock	Active on the positive edge to sample all inputs.
CKE	Clock Enable	Masks system clock to freeze operation from the next clock cycle. CKE should be enabled at least on cycle prior new command. Disable input buffers for power down in standby
/CS	Chip Select	Disables or Enables device operation by masking or enabling all input except CLK, CKE and L(U)DQM
A0~A10	Address	Row / Column address are multiplexed on the same pins. Row address : A0~A10 Column address : A0~A7
DQ0~DQ15	Data	Data inputs / outputs are multiplexed on the same pins.
L(U)DQM	Data Mask	Makes data output Hi-Z,
/RAS	Row Address Strobe	Latches row addresses on the positive edge of the CLK with /RAS low
/CAS	Column Address Strobe	Latches Column addresses on the positive edge of the CLK with /CAS low
/WE	Write Enable	Enables write operation and row recharge.
VDD/VSS	Power Supply/Ground	Power and Ground for the input buffers and the core logic.
VDDQ/VSSQ	Data Output Power/Ground	Power supply for output buffers.
NC	No Connection	This pin is recommended to be left No Connection on the device.

Block Diagram

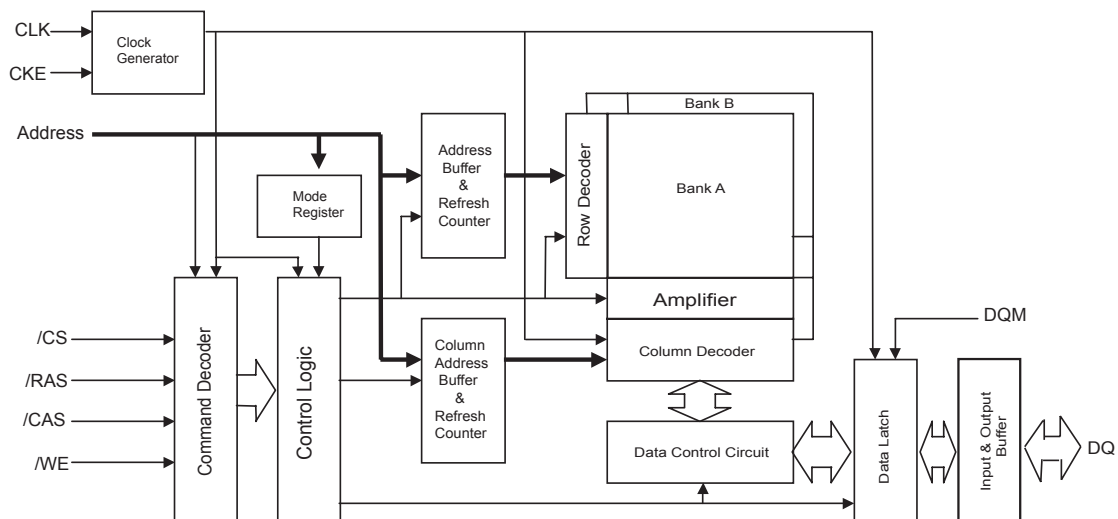

Absolute Maximum Ratings

Parameter	Symbol	Value	Unit
Voltage on any pin relative to Vss	V _{IN} , V _{out}	-0.3~ 4.6	V
Voltage on VDD supply relative to Vss	V _{DD} , V _{DDQ}	-0.3~ 4.6	V
Storage temperature	T _{STG}	-55 ~ +150	°C
Power dissipation	P _D	1	W
Short circuit current	I _{os}	50	mA

Note : Permanent device damage may occur if ABSOLUTE MAXIMUM RATING are exceeded.

Functional operation should be restricted to recommended operating condition.

Exposure to higher than recommended voltage for extended periods of time could affect device reliability.

DC Operating Condition

Voltage referenced to Vss = 0V, T_A = 0 to 70 °C

Parameter	Symbol	Min	Typ	Max	Unit	Note
Supply voltage	V _{DD} , V _{DDQ}	3.0	3.3	3.6	V	
Input logic high voltage	V _{IH}	2.0		V _{DD} +0.3	V	1
Input logic low voltage	V _{IL}	-0.3		0.8	V	2
Output logic high voltage	V _{OH}	2.4	-	-	V	I _{OH} =-2mA
Output logic low voltage	V _{OL}	-	-	0.4	V	I _{OL} =2mA
Input leakage current	I _{IL}	-5	-	5	uA	3
Output leakage current	I _{OL}	-5	-	5	uA	4

Note : 1. V_{IH} (max)=V_{DDH}+2.0V with a pulse width < 3ns

2. V_{IL}(min)=V_{SSQ}-2.0V with a pulse < 3ns and - 1.5V with a pulse < 5ns

3. Any input 0V ≤ V_{IN} ≤ V_{DD} + 0.3V, all other pins are not under test = 0V.

4. Dout is disabled, 0V ≤ V_{OUT} ≤ V_{DD}.

AC Operating Condition

Voltage referenced to Vss = 0V, T_A = 0 to 70 °C

Parameter	Symbol	Value	Unit	Note
AC input high / low level voltage	V _{IH} / V _{IL}	1.4 / 1.4	V	
Input timing measurement reference level voltage	V _{trip}	1.4	V	
Input rise / fall time	T _R / t _F	1	ns	
Output timing measurement reference level	V _{outf}	1.4	V	
Output load capacitance for access time measurement	CL	50	pF	

Capacitance

TA=25°C, f=1Mhz, VDD=3.3V

Parameter	Pin	Symbol	Min	Max	Unit
Input capacitance	CLK	C11	2.5	4	pF
	A0~A11,BA0,BA1,CKE,/CS,/RAS, /CAS,/WE,DQM	C12	2.5	5	pF
Data input / output capacitance	DQM	C1/O	4	6.5	pF

Output load circuit

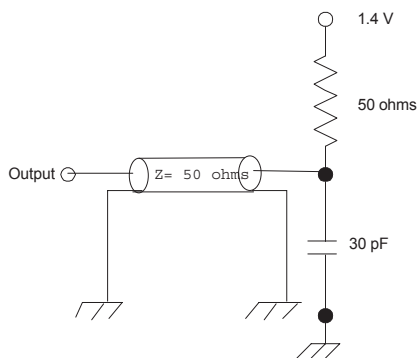

DC Characteristics I

Parameter	Symbol	Min	Max	Unit	Note
Input leakage current	I _{LI}	-5	5	uA	1
Output leakage current	I _{LO}	-5	5	uA	2
Output high voltage	V _{OH}	2.4	-	V	I _{OH} = -2mA
Output low voltage	V _{OL}	-	0.4	V	I _{OL} = 2mA

Note : 1. V_{IN} = 0 TO 3.6V, All other pins are not tested under V_{IN} = 0V.

2. D_{OUT} is disabled, V_{OUT} = 0 to 3.6.

DC Characteristics II

Parameter	Symbol	Test condition	Speed			Unit	Note
			-5	-6	-7		
Operating Current	IDD1	Burst length=1, One bank active $t_{RC} \geq t_{RC}(\min)$, $I_{OL}=0\text{mA}$	70	60	50	mA	1
Precharge standby current in power down mode	IDD2P	$CKE \leq V_{IL}(\max)$, $t_{CK}=\min$	1			mA	
	IDD2PS	$CKE \leq V_{IL}(\max)$, $t_{CK}=\infty$	1				
Precharge standby current in Non power down mode	IDD2N	$CKE \geq V_{IH}(\min)$, $/CS \geq V_{IH}(\min)$, $t_{CK}=\min$ input signals are changed one time during 2clks. All other pins $\geq V_{DD}-0.2\text{V}$ or $\leq 0.2\text{V}$	35	30	25	mA	
	IDD2NS	$CKE \geq V_{IH}(\min)$, $t_{CK}=\infty$ Input signals are stable.	8				
Active standby current in power down mode	IDD3P	$CKE \leq V_{IL}(\max)$, $t_{CK}=\min$	45	40	35	mA	
Active standby current in Non power down mode	IDD3N	$CKE \geq V_{IH}(\min)$, $/CS \geq V_{IH}(\min)$, $t_{CK}=\min$ input signals are changed one time during 2clks. All other pins $\geq V_{DD}-0.2\text{V}$ or $\leq 0.2\text{V}$	3			mA	
Burst mode operating current	IDD4	$t_{CK} \geq t_{CK}(\min)$, $I_{OL}=0\text{mA}$ All banks active	120	110	100	mA	1
Auto refresh current	IDD5	$t_{RRC} \geq t_{RRC}(\min)$, All banks active	60	55	50	mA	2
Self refresh current	IDD6	$CKE \leq 0.2\text{V}$	200			uA	

Note: 1. IDD1 and IDD4 depend on output loading and cycle rates. Specified values are measured with the output open.

2. Min. of t_{RRC} is shown at AC characteristics.

AC Characteristics

Parameter		Symbol	-5		-6		-7		Unit	Note
			Min	Max	Min	Max	Min	Max		
System clock	/CAS Latency = 3	tCK3	5	1000	6	1000	7	1000	ns	
Cycle time	/CAS Latency = 2	tCK2	7		8		10			
Clock high pulse width		tCHW	2	-	2	-	2	-	ns	1
Clock low pulse width		tCLW	2	-	2	-	2	-	ns	1
Access time	/CAS Latency = 3	tAC3	-	4.5	-	5	-	5	ns	2
form clock	/CAS Latency = 2	tAC2	-	4.5	-	5.5	-	5.5		
Row cycle time		tRC	54	-	60	-	65	-	ns	
/RAS to /CAS delay		tRCD	14	-	18	-	20	-	ns	
/RAS active time		tRAS	40	100K	42	100K	45	100K	ns	
/RAS precharge time		tRP	14	-	18	-	20	-	ns	
/RAS to /RAS bank active delay		tRRD	10	-	12	-	14	-	ns	
/CAS to /CAS delay		tCCD	1	-	1	-	1	-	CLK	
Data – out hold time		tOH	1.5	-	2	-	2.5	-	ns	
Data – input setup time		tDS	1.5	-	1.5	-	1.5	-	ns	1
Data – input hold time		tDH	1	-	1	-	1	-	ns	1
Address setup time		tAS	1.5	-	1.5	-	1.5	-	ns	1
Address hold time		tAH	1	-	1	-	1	-	ns	1
Power down exit time		tPDE	5	-	5	-	5	-	CLK	
Refresh time		tREF		64		64		64	ms	

Note : 1. Assume tR / tF (input rise and fall time) is 1 ns.

2. Access times to be measured with input signals of 1v / ns edge rate.

3.A new command can be given tRRC after self refresh exit.

Command Truth-Table

Command		CKEn-1	CKEn	/CS	/RAS	/CAS	/WE	A10	A9-A0
Mode Register Set		H	X	L	L	L	L	X	V
No Operation		H	X	L	H	H	H	X	X
Bank Active		H	X	L	L	H	H	V	
Read		H	X	L	H	L	H	L	V
Read with Auto Precharge								H	
Write		H	X	L	H	L	L	L	V
Write with Auto Precharge								H	
Precharge All Bank		H	X	L	L	H	L	H	X
Precharge select Bank								L	X
Burst Stop		H	X	L	H	H	L	X	
DQM		H	X					X	
Self Refresh	Entry	H	L	L	L	L	H	X	
	Exit	L	H	H	X	X	X		
				L	H	H	H		
Precharge Power down	Entry	H	L	X				X	
	Exit	L	H	X					
Clock Suspend	Entry	H	L	X				X	
	Exit	L	L	X					

Package Information

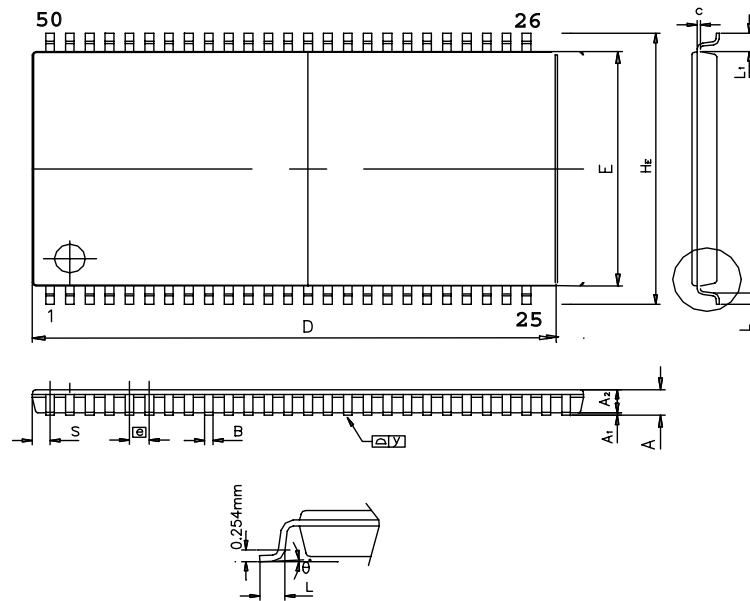

SYMBOL	MILLIMETER			INCH		
	MIN.	NOM.	MAX.	MIN.	NOM.	MAX.
A			1.20			0.047
A1	0.05	0.10	0.15	0.002		0.006
A2	0.95	1.00	1.05	0.037	0.039	0.041
B	0.30		0.45	0.012		0.018
c	0.12		0.21	0.005		0.008
D	21.08 BSC			0.830 BSC		
H _E	11.56	11.76	11.96	0.460	0.463	0.471
E	10.03	10.16	10.29	0.395	0.400	0.405
e	0.80 BSC			0.0315		
L	0.40	0.50	0.60	0.016	0.020	0.024
L1	0.80 REF			0.031 REF		
S	0.71 REF			0.028 REF		
θ	0°	-	5°	0°	-	5°

400mil 50pin TSOP II Package



LittleDiode supplies new, hard to find or obsolete electronic components and semiconductors all over the world.

With over two million different components listed you are sure to find the part you need.

Feel free to visit us today at our online store:

LittleDiode.com

Looking forward to providing you with the best possible service.