

Hi-Rel NPN bipolar transistor 160 V, 0.5 A

Datasheet - production data

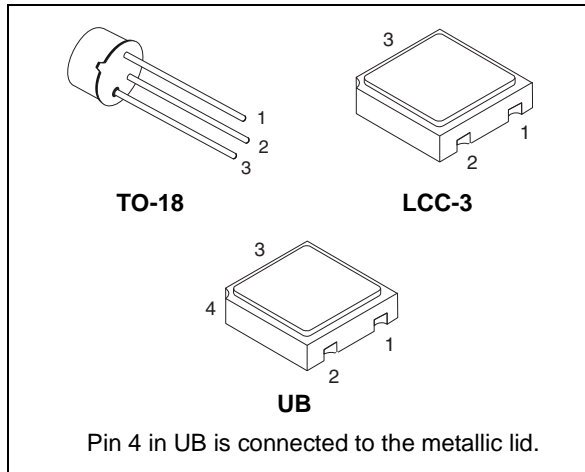
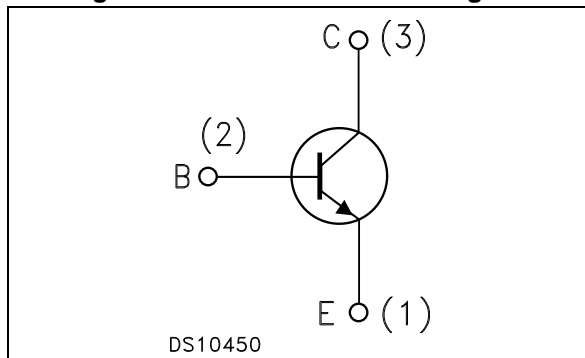

Figure 1. Internal schematic diagram



Features

BV_{CEO}	160 V
I_C (max)	0.5 A
H_{FE} at 5 V - 10 mA	> 80

- Hermetic packages
- ESCC and JANS qualified
- Up to 100 krad(Si) low dose rate

Description

The 2N5551HR is a silicon planar NPN transistor specifically designed and housed in hermetic packages for aerospace and Hi-Rel applications. It is available in the JAN qualification system (MIL-PRF19500 compliance) and in the ESCC qualification system (ESCC 5000 compliance). In case of discrepancies between this datasheet and the relevant agency specification, the latter takes precedence.

Table 1. Device summary

Device	Qualification system	Agency specification	Package	Radiation level	EPPL
JANSR2N5551UBx	JANSR	MIL-PRF-19500/761	UB	100 krad high and low dose rate	-
JANS2N5551UBx	JANS	MIL-PRF-19500/761	UB	-	-
2N5551RUBx	ESCC Flight	5201/019	UB	100 krad - low dose rate	Target
2N5551UBx	ESCC Flight	5201/019	UB	-	Target
SOC5551RHRx	ESCC Flight	5201/019	LCC-3	100 krad - low dose rate	Yes
SOC5551HRx	ESCC Flight	5201/019	LCC-3	-	Yes
2N5551RHRx	ESCC Flight	5201/019	TO-18	100 krad - low dose rate	-
2N5551HRx	ESCC Flight	5201/019	TO-18	-	-

Contents

1	Electrical ratings	3
2	Electrical characteristics	4
2.1	Electrical characteristics (curves)	5
3	Radiation hardness assurance	6
4	Package mechanical data	9
4.1	LCC-3	9
4.2	TO-18	10
4.3	UB	11
5	Order codes	13
6	Shipping details	15
6.1	Date code	15
6.2	Documentation	15
7	Revision history	16

1 Electrical ratings

Table 2. Absolute maximum ratings

Symbol	Parameter	Value	Unit
V_{CBO}	Collector-base voltage ($I_E = 0$)	180	V
V_{CEO}	Collector-emitter voltage ($I_B = 0$)	160	V
V_{EBO}	Emitter-base voltage ($I_C = 0$)	6	V
I_C	Collector current for TO-18	0.6	A
	for LCC-3 and UB	0.5	A
P_{TOT}	Total dissipation at $T_{amb} \leq 25\text{ °C}$ for TO-18	0.36	W
	for LCC-3 and UB	0.36	W
	for LCC-3 and UB ⁽¹⁾	0.58	W
	Total dissipation at $T_c \leq 25\text{ °C}$ for TO-18	1.2	W
T_{STG}	Storage temperature	-65 to 200	°C
T_J	Max. operating junction temperature	200	°C

1. When mounted on a 8 x 10 x 0.6 mm ceramic substrate.

Table 3. Thermal data for through-hole package

Symbol	Parameter	Value	Unit
R_{thJC}	Thermal resistance junction-case max	146	°C/W
R_{thJA}	Thermal resistance junction-ambient max	486	°C/W

Table 4. Thermal data for SMD package

Symbol	Parameter	Value	Unit
R_{thJA}	Thermal resistance junction-ambient max	486	°C/W
	Thermal resistance junction-ambient ⁽¹⁾ max	302	°C/W

1. When mounted on a 8 x 10 x 0.6 mm ceramic substrate.

2 Electrical characteristics

$T_{\text{case}} = 25\text{ °C}$ unless otherwise specified.

Table 5. Electrical characteristics

Symbol	Parameter	Test conditions	Min.	Typ.	Max.	Unit
I_{CBO}	Collector-base cut-off current ($I_{\text{E}} = 0$)	$V_{\text{CB}} = 120\text{ V}$ $V_{\text{CB}} = 120\text{ V}$ $T_{\text{C}} = 150\text{ °C}$		-	50 50	nA μA
I_{EBO}	Emitter-base cut-off current ($I_{\text{C}} = 0$)	$V_{\text{EB}} = 4\text{ V}$		-	50	nA
$V_{(\text{BR})\text{CBO}}$	Collector-base breakdown voltage ($I_{\text{E}} = 0$)	$I_{\text{C}} = 100\text{ }\mu\text{A}$	180	-		V
$V_{(\text{BR})\text{CEO}}^{(1)}$	Collector-emitter breakdown voltage ($I_{\text{B}} = 0$)	$I_{\text{C}} = 1\text{ mA}$	160	-		V
$V_{(\text{BR})\text{EBO}}$	Emitter-base breakdown voltage ($I_{\text{C}} = 0$)	$I_{\text{E}} = 10\text{ }\mu\text{A}$	6	-		V
$V_{\text{CE}(\text{sat})}^{(1)}$	Collector-emitter saturation voltage	$I_{\text{C}} = 10\text{ mA}$ $I_{\text{B}} = 1\text{ mA}$ $I_{\text{C}} = 50\text{ mA}$ $I_{\text{B}} = 5\text{ mA}$		-	0.15 0.2	V V
$V_{\text{BE}(\text{sat})}^{(1)}$	Base-emitter saturation voltage	$I_{\text{C}} = 10\text{ mA}$ $I_{\text{B}} = 1\text{ mA}$ $I_{\text{C}} = 50\text{ mA}$ $I_{\text{B}} = 5\text{ mA}$		-	1 1	V V
$h_{\text{FE}}^{(1)}$	DC current gain	$I_{\text{C}} = 1\text{ mA}$ $V_{\text{CE}} = 5\text{ V}$ $I_{\text{C}} = 10\text{ mA}$ $V_{\text{CE}} = 5\text{ V}$ $I_{\text{C}} = 50\text{ mA}$ $V_{\text{CE}} = 5\text{ V}$ $I_{\text{C}} = 10\text{ mA}$ $V_{\text{CE}} = 5\text{ V}$ $T_{\text{amb}} = -55\text{ °C}$	80 80 30 20	-	250	
h_{fe}	Small signal current gain	For ESCC $V_{\text{CE}} = 10\text{ V}$ $I_{\text{C}} = 10\text{ mA}$ $f > 1\text{ kHz}$	50	-		
		For JANS $V_{\text{CE}} = 10\text{ V}$ $I_{\text{C}} = 10\text{ mA}$ $f > 20\text{ kHz}$	2.5			
h_{fe}	Small signal current gain	$V_{\text{CE}} = 10\text{ V}$ $I_{\text{C}} = 10\text{ mA}$ $f > 100\text{ MHz}$	1	-		
C_{obo}	Output capacitance ($I_{\text{E}} = 0$)	$V_{\text{CB}} = 10\text{ V}$ $f = 1\text{ MHz}$		-	6	pF
C_{ebo}	Emitter-base capacitance ($I_{\text{C}} = 0$)	For ESCC $V_{\text{EB}} = 5\text{ V}$ $f = 1\text{ MHz}$		-	20	pF
		For JANS $V_{\text{EB}} = 500\text{ mV}$ $f = 1\text{ MHz}$			45	pF

1. Pulsed duration = 300 μs , duty cycle \leq 1.5%

2.1 Electrical characteristics (curves)

Figure 2. h_{FE} @ $V_{CE} = 5\text{ V}$

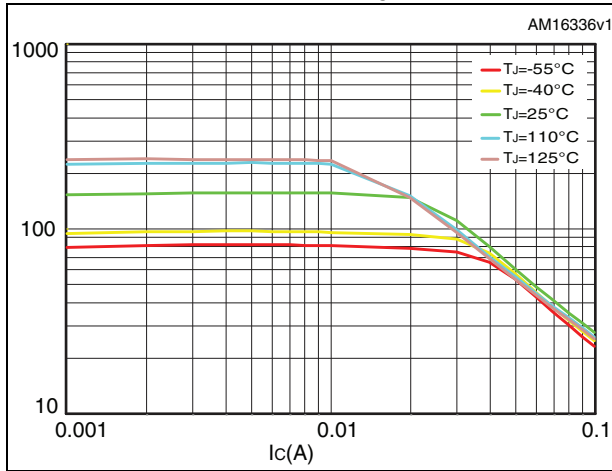

Figure 3. $V_{CE(sat)}$ @ $h_{FE} = 10$

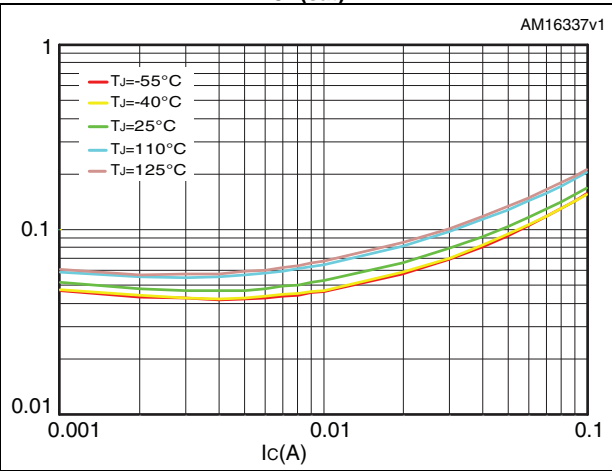
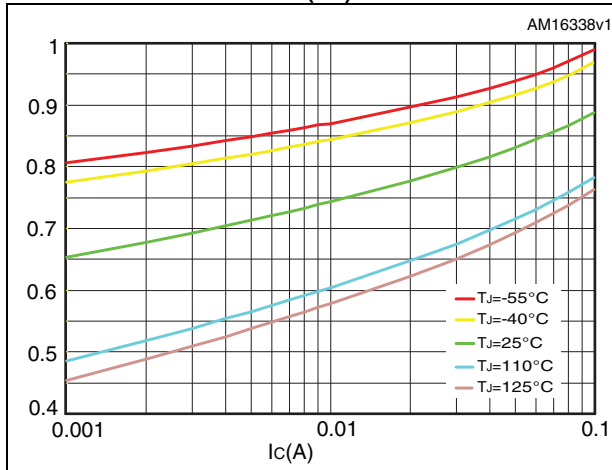

Figure 4. $V_{BE(sat)}$ @ $h_{FE} = 10$



3 Radiation hardness assurance

The products guaranteed in radiation within the JANS system fully comply with the MIL-PRF-19500/761 specification.

The products guaranteed in radiation within the ESCC system fully comply with the ESCC 5201/019 and ESCC 22900 specifications.

JANS radiation assurance

ST JANS parts guaranteed at 100 krad (Si), tested, in full compliancy with the MIL-PRF-19500 specification, specifically the Group D, subgroup 2 inspection, between 50 and 300 rad/s. On top of the standard JANSR high dose rate by wafer lot guarantee, ST 2N5551HR series include an additional wafer by wafer 100 krad Low dose rate guarantee at 0.1 rad/s, identical to the ESCC 100 krad guarantee. It is supported with the same radiation verification test report provided with each shipment. A brief summary of the standard High Dose Rate by wafer lot JANSR guarantee is provided below:

- All test are performed in accordance to MIL-PRF-19500 and test method 1019 of MIL-STD-750 for total Ionizing dose.

The table below provides for each monitored parameters of the test conditions and the acceptance criteria.

Table 6. MIL-PRF-19500 (test method 1019) post radiation electrical characteristics

Symbol	Parameter	Test conditions	Value		Unit
			Min.	Max.	
I_{CBO}	Collector to base cutoff current	$V_{CB} = 120 \text{ V}$		100	nA
I_{EBO}	Emitter to base cutoff current	$V_{EB} = 4 \text{ V}$		100	nA
$V_{(BR)CEO}$	Breakdown voltage, collector to emitter	$I_C = 1 \text{ mA}$	184		V
$V_{(BR)BCO}$	Breakdown voltage, base to collector	$I_C = 100 \mu\text{A}$	207		V
$V_{(BR)EBO}$	Breakdown voltage, emitter to base	$I_{EB} = 10 \mu\text{A}$	6.9		V
h_{FE}	Forward-current transfer ratio	$V_{CE} = 5 \text{ V}; I_C = 1 \text{ mA}$	[40] ⁽¹⁾		
		$V_{CE} = 5 \text{ V}; I_C = 10 \text{ mA}$	[40] ⁽¹⁾	250	
		$V_{CE} = 5 \text{ V}; I_C = 50 \text{ mA}$	[15] ⁽¹⁾		
$V_{CE(sat)}$	Collector-emitter saturation voltage	$I_C = 10 \text{ mA}; I_B = 1 \text{ mA}$		0.1725	V
		$I_C = 50 \text{ mA}; I_B = 5 \text{ mA}$		0.23	
$V_{BE(sat)}$	Base-emitter saturation voltage	$I_C = 10 \text{ mA}; I_B = 1 \text{ mA}$		1.15	V
		$I_C = 50 \text{ mA}; I_B = 5 \text{ mA}$		1.15	

1. See method 1019 of MIL-STD-750 for how to determine $[h_{FE}]$ by first calculating the delta ($1/h_{FE}$) from the pre- and Post-radiation h_{FE} . Notice the $[h_{FE}]$ is not the same as h_{FE} and cannot be measured directly. The $[h_{FE}]$ value can never exceed the pre-radiation minimum h_{FE} that it is based upon.

ESCC radiation assurance

Each product lot is tested according to the ESCC basic specification 22900, with a minimum of 11 samples per diffusion lot and 5 samples per wafer, one sample being kept as unirradiated sample, all of them being fully compliant with the applicable ESCC generic and/or detailed specification.

ST goes beyond the ESCC specification by performing the following procedure:

- Test of 11 pieces by wafer, 5 biased at least 80% of $V_{(BR)CEO}$, 5 unbiased and 1 kept for reference
- Irradiation at 0.1 rad (Si)/s
- Acceptance criteria of each individual wafer if as 100 krad guaranteed if all 10 samples comply with the post radiation electrical characteristics provided in [Table 7](#)
- Delivery together with the parts of the radiation verification test (RVT) report of the particular wafer used to manufacture the products. This RVT includes the value of each parameter at 30, 50, 70 and 100 krad (Si) and after 24 hour annealing at room temperature and after an additional 168 hour annealing at 100°C.

Table 7. ESCC 5201/019 post radiation electrical characteristics

Symbol	Parameter	Test conditions	Min.	Typ.	Max.	Unit
I_{CBO}	Collector cut-off current ($I_E = 0$)	$V_{CB} = 120 \text{ V}$		-	50	nA
I_{EBO}	Emitter cut-off current ($I_C = 0$)	$V_{EB} = 4 \text{ V}$		-	50	nA
$V_{(BR)CBO}$	Collector-base breakdown voltage ($I_E = 0$)	$I_C = 100 \mu\text{A}$	180	-		V
$V_{(BR)CEO}^{(1)}$	Collector-emitter breakdown voltage ($I_B = 0$)	$I_C = 1 \text{ mA}$	160	-		V
$V_{(BR)EBO}$	Emitter-base breakdown voltage ($I_C = 0$)	$I_E = 10 \mu\text{A}$	6	-		V
$V_{CE(sat)}^{(1)}$	Collector-emitter saturation voltage	$I_C = 10 \text{ mA}$ $I_B = 1 \text{ mA}$ $I_C = 50 \text{ mA}$ $I_B = 5 \text{ mA}$		-	0.2 0.2	V V
$V_{BE(sat)}^{(1)}$	Base-emitter saturation voltage	$I_C = 10 \text{ mA}$ $I_B = 1 \text{ mA}$ $I_C = 50 \text{ mA}$ $I_B = 5 \text{ mA}$			1 1	V V
$[h_{FE}]^{(1)}$	Post irradiation gain calculation ⁽²⁾	$I_C = 1 \text{ mA}$ $V_{CE} = 5 \text{ V}$ $I_C = 10 \text{ mA}$ $V_{CE} = 5 \text{ V}$ $I_C = 50 \text{ mA}$ $V_{CE} = 5 \text{ V}$	[40] [40] [15]	-	250	

1. Pulsed duration = 300 μs , duty cycle $\leq 2\%$

2. The post-irradiation gain calculation of $[h_{FE}]$, made using h_{FE} measurements from prior to and on completion of irradiation testing and after each annealing step if any, shall be as specified in MILSTD-750 method 1019.

4 Package mechanical data

In order to meet environmental requirements, ST offers these devices in different grades of ECOPACK[®] packages, depending on their level of environmental compliance. ECOPACK[®] specifications, grade definitions and product status are available at: www.st.com. ECOPACK[®] is an ST trademark.

4.1 LCC-3

Figure 5. LCC-3 drawings

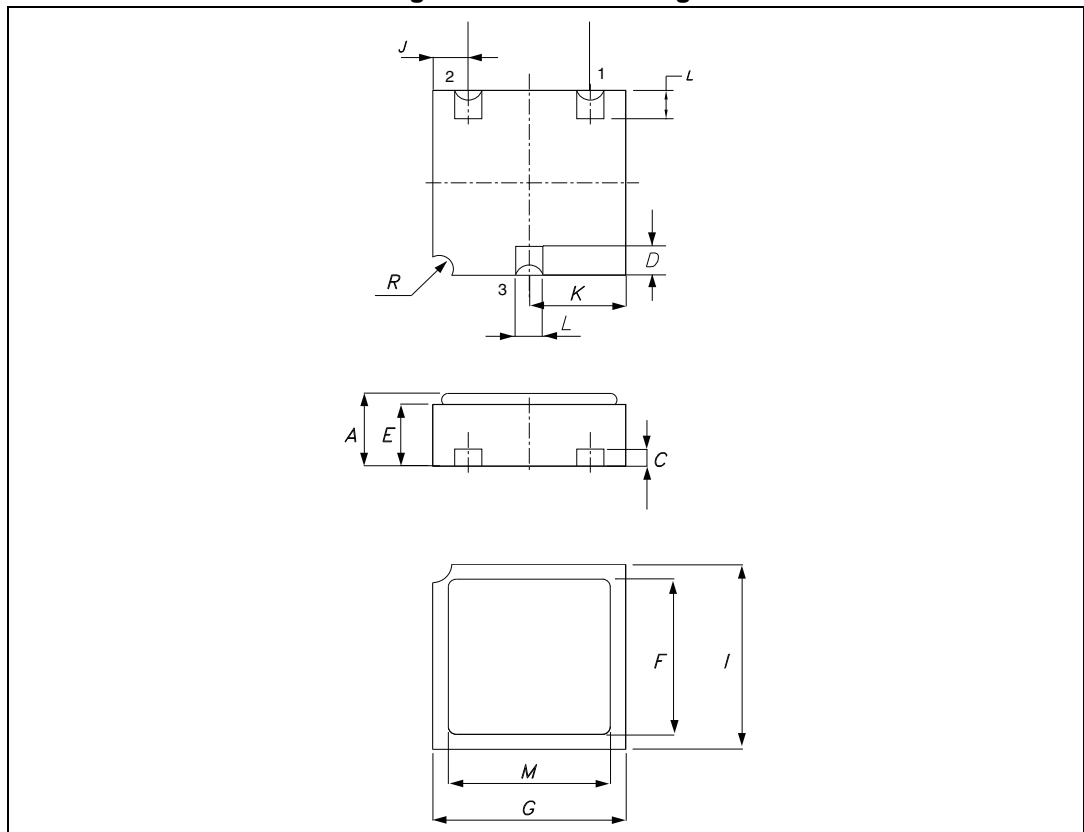
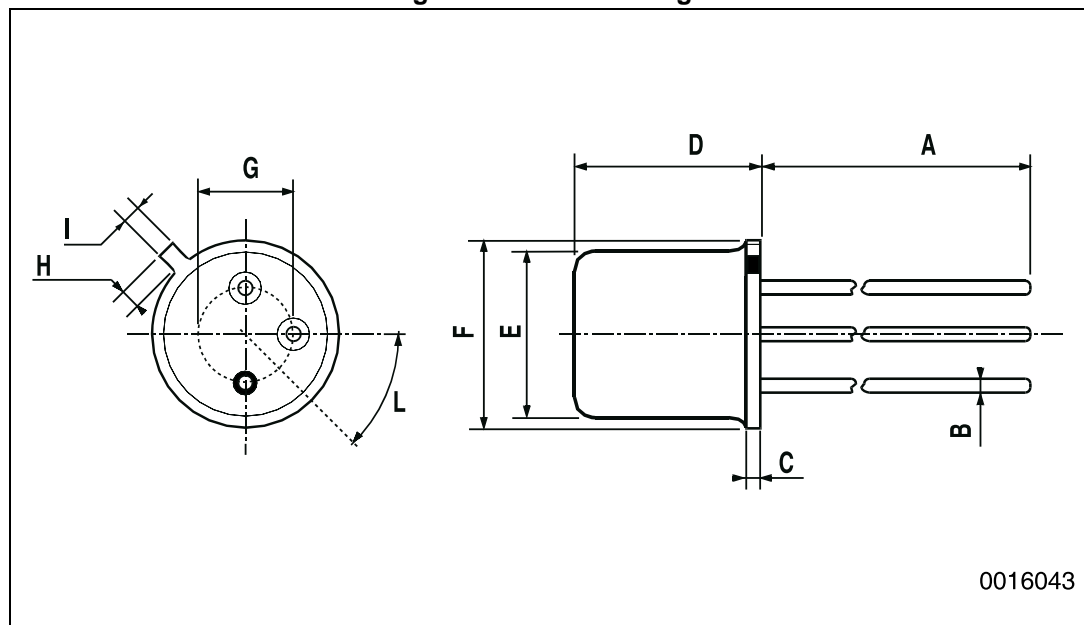

Table 8. LCC-3 mechanical data

Dim.	mm.		
	Min.	Typ.	Max.
A	1.16		1.42
C	0.45	0.50	0.56
D	0.60	0.76	0.91
E	0.91	1.01	1.12
F	1.95	2.03	2.11
G	2.92	3.05	3.17
I	2.41	2.54	2.66
J	0.42	0.57	0.72
K	1.37	1.52	1.67
L	0.40	0.50	0.60
M	2.46	2.54	2.62
N	1.80	1.90	2.00
R		0.30	

4.2 TO-18

Figure 6. TO-18 drawings



0016043

Table 9. TO-18 mechanical data

Dim.	mm.		
	Min.	Typ.	Max.
A		12.7	
B			0.49
D			5.3
E			4.9
F			5.8
G	2.54		
H			1.2
I			1.16
L	45°		

4.3 UB

Figure 7. UB drawing

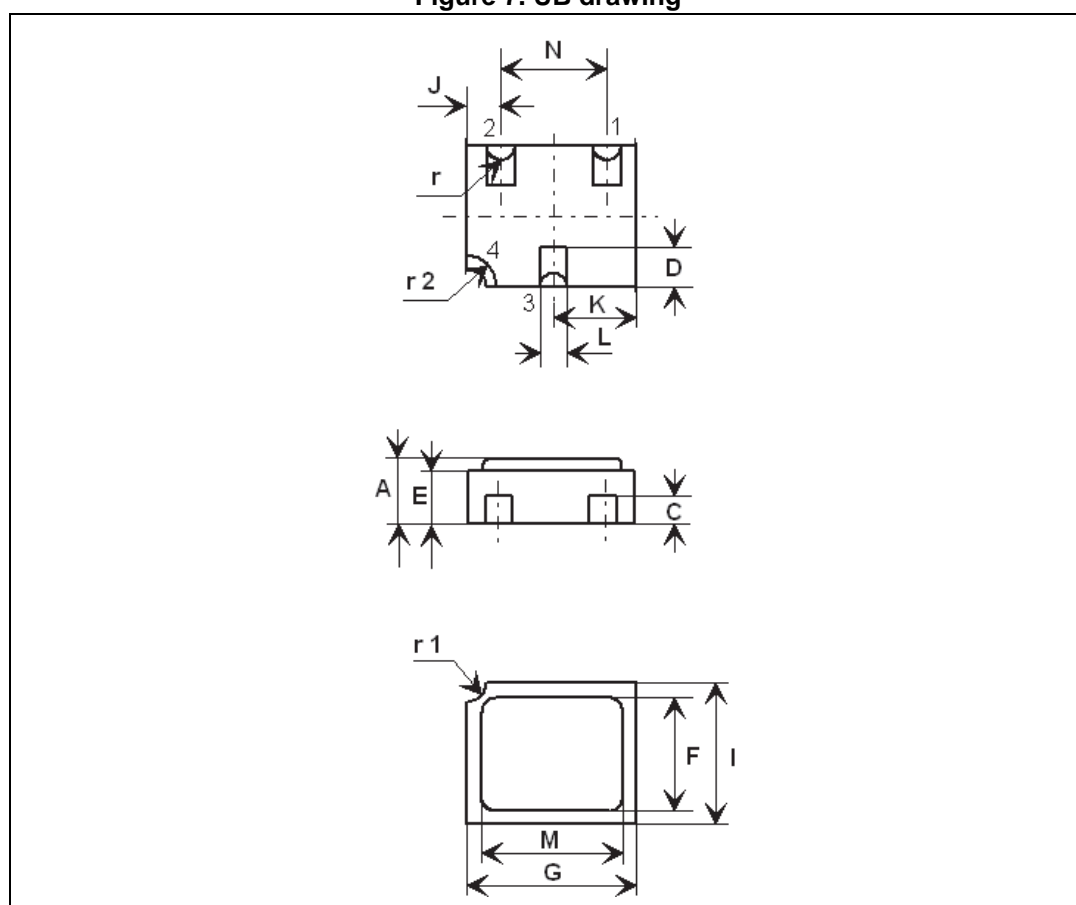

Table 10. UB mechanical data

Dim.	mm		
	Min.	Typ.	Max.
A	-	12.70	14.20
B		0.40	0.49
C		0.58	0.74
D		6.00	6.40
E		8.15	8.25
F		9.10	9.20
G		4.93	5.23
H		0.85	0.95
I		0.75	0.85
L		42°	48°



5 Order codes

Table 11. Order codes

CPN	Agency specification	EPPL	Quality level	Radiation level ⁽¹⁾	Package	Lead finish	Marking ⁽²⁾	Packing
J2N5551UB1	-	-	Engineering model JANS	-	UB	Gold	J5551UB1	WafflePack
2N5551UB1	-	-	Engineering model ESCC	-	UB	Gold	2N5551UB1	WafflePack
SOC55511	-	-	Engineering model ESCC	-	LCC-3	Gold	SOC55511	WafflePack
JANSR2N5551UBG	MIL-PRF-19500/761	-	JANSR	100 krad high and low dose rate	UB	Gold	JSR5551	WafflePack
JANSR2N5551UBT	MIL-PRF-19500/761	-	JANSR	100 krad high and low dose rate	UB	Solder Dip	JSR5551	WafflePack
JANS2N5551UBG	MIL-PRF-19500/761	-	JANS	-	UB	Gold	JS5551	WafflePack
JANS2N5551UBT	MIL-PRF-19500/761	-	JANS	-	UB	Solder Dip	JS5551	WafflePack
2N5551RUBG	5201/019/08R	Target	ESCC Flight	100 krad - low dose rate	UB	Gold	520101908R	WafflePack
2N5551RUBT	5201/019/09R	Target	ESCC Flight	100 krad - low dose rate	UB	Solder Dip	520101909R	WafflePack
2N5551UBG	5201/019/08	Target	ESCC Flight	-	UB	Gold	520101908	WafflePack
2N5551UBT	5201/019/09	Target	ESCC Flight	-	UB	Solder Dip	520101909	WafflePack
SOC5551RHRG	5201/019/04R	Yes	ESCC Flight	100 krad - low dose rate	LCC-3	Gold	520101904R	WafflePack
SOC5551RHRT	5201/019/05R	Yes	ESCC Flight	100 krad - low dose rate	LCC-3	Solder Dip	520101905R	WafflePack
SOC5551HRG	5201/019/04	Yes	ESCC Flight	-	LCC-3	Gold	520101904	WafflePack



Table 11. Order codes (continued)

CPN	Agency specification	EPPL	Quality level	Radiation level ⁽¹⁾	Package	Lead finish	Marking ⁽²⁾	Packing
SOC5551HRT	5201/019/05	Yes	ESCC Flight	-	LCC-3	Solder Dip	520101905	WafflePack
2N5551RHRG	5201/019/01R	-	ESCC Flight	100 krad - low dose rate	TO-18	Gold	520101901R	Strip Pack
2N5551RHRT	5201/019/02R	-	ESCC Flight	100 krad - low dose rate	TO-18	Solder Dip	520101902R	Strip Pack
2N5551HRG	5201/019/01	-	ESCC Flight	-	TO-18	Gold	520101901	Strip Pack
2N5551HRT	5201/019/02	-	ESCC Flight	-	TO-18	Solder Dip	520101902	Strip Pack

1. High dose rate as per MIL-PRF-19500 specification group D, subgroup 2 inspection. Low dose rate as per ESCC specification 22900.
2. Specific marking only. The full marking includes in addition: For the Engineering Models: ST logo, date code; country of origin (FR). For ESCC flight parts: ST logo, date code, country of origin (FR), ESA logo, serial number of the part within the assembly lot. For JANS flight parts: ST logo, date code, country of origin (FR), manufacturer code (CSTM), serial number of the part within the assembly lot.

Contact ST sales office for information about the specific conditions for:

- Products in die form
- Other JANS quality levels
- Tape and reel packing

6 Shipping details

6.1 Date code

Date code xyywwz is structured as below table:

Table 12. Date code

	x	yy	ww	z
EM (ESCC & JANS)	3	last two digits of the year	week digits	lot index in the week
ESCC FLIGHT	-			
JANS FLIGHT (diffused in Singapore)	W			

6.2 Documentation

Table 13. Documentation provided for each type of product

Quality level	Radiation level	Documentation
Engineering model	-	-
JANS Flight	-	Certificate of conformance
JANSR Flight	MIL-STD 100 krad	Certificate of conformance 50 rad/s radiation verification test report
	ST 100 krad	Certificate of conformance 0.1 rad/s radiation verification test report on each wafer
ESCC Flight	-	Certificate of conformance
	100 krad	Certificate of conformance 0.1 rad/s radiation verification test report

7 Revision history

Table 14. Document revision history

Date	Revision	Changes
04-Jan-2010	1	Initial release
17-May-2010	2	Modified: Table 1: Device summary and Table 9 on page 11
12-Jul-2010	3	Modified: Table 1: Device summary and Table 9 on page 11
13-Nov-2012	4	Added: Section 2.1: Electrical characteristics (curves)
12-Dec-2013	5	Updated Table 1: Device summary , Table 2: Absolute maximum ratings and Section 4: Package mechanical data . Added Section 5: Order codes and Section 6: Shipping details
27-Mar-2014	6	Updated Table 1: Device summary , Section 3: Radiation hardness assurance , Figure 7: UB drawing , Section 5: Order codes and Table 13: Documentation provided for each type of product . Minor text changes.
01-Apr-2014	7	Inserted note in package silhouette on cover page.
14-Jul-2014	8	Updated Table 1: Device summary and Table 11: Order codes .

IMPORTANT NOTICE – PLEASE READ CAREFULLY

STMicroelectronics NV and its subsidiaries ("ST") reserve the right to make changes, corrections, enhancements, modifications, and improvements to ST products and/or to this document at any time without notice. Purchasers should obtain the latest relevant information on ST products before placing orders. ST products are sold pursuant to ST's terms and conditions of sale in place at the time of order acknowledgement.

Purchasers are solely responsible for the choice, selection, and use of ST products and ST assumes no liability for application assistance or the design of Purchasers' products.

No license, express or implied, to any intellectual property right is granted by ST herein.

Resale of ST products with provisions different from the information set forth herein shall void any warranty granted by ST for such product.

ST and the ST logo are trademarks of ST. All other product or service names are the property of their respective owners.

Information in this document supersedes and replaces information previously supplied in any prior versions of this document.

© 2014 STMicroelectronics – All rights reserved



LittleDiode supplies new, hard to find or obsolete electronic components and semiconductors all over the world.

With over two million different components listed you are sure to find the part you need.

Feel free to visit us today at our online store:

LittleDiode.com

Looking forward to providing you with the best possible service.