

General purpose amplification (12V, 1.5A)

2SD2674

●Application

Low frequency amplifier

●Features

- 1) A collector current is large.
- 2) Collector saturation voltage is low.

$$V_{CE(sat)} \leq 200\text{mV}$$

$$\text{at } I_C = 500\text{mA} / I_B = 25\text{mA}$$

●External dimensions (Units : mm)

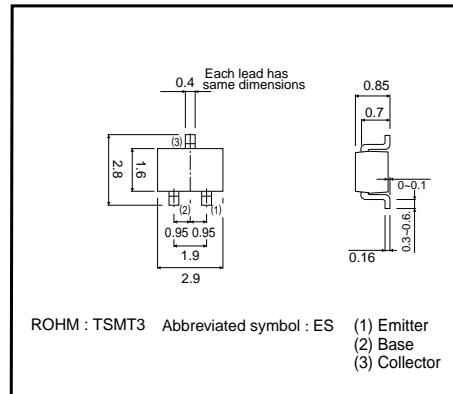

●Absolute maximum ratings (Ta=25°C)

| Parameter | Symbol | Limits | Unit |
|------------------------------|-----------|----------|------|
| Collector-base voltage | V_{CB0} | 15 | V |
| Collector-emitter voltage | V_{CE0} | 12 | V |
| Emitter-base voltage | V_{EB0} | 6 | V |
| Collector current | I_C | 1.5 | A |
| | I_{CP} | 3 | A * |
| Power dissipation | P_C | 500 | mW |
| Junction temperature | T_j | 150 | °C |
| Range of storage temperature | T_{stg} | -55~+150 | °C |

*Single pulse, $P_w=1\text{ms}$

●Packaging specifications

| Type | Package | Taping |
|---------|------------------------------|--------|
| | Code | TL |
| | Basic ordering unit (pieces) | 3000 |
| 2SD2674 | | ○ |

●Electrical characteristics (Ta=25°C)

| Parameter | Symbol | Min. | Typ. | Max. | Unit | Conditions |
|--------------------------------------|---------------|------|------|------|------|--|
| Collector-base breakdown voltage | BV_{CB0} | 15 | - | - | V | $I_C=10\mu\text{A}$ |
| Collector-emitter breakdown voltage | BV_{CE0} | 12 | - | - | V | $I_C=1\text{mA}$ |
| Emitter-base breakdown voltage | BV_{EB0} | 6 | - | - | V | $I_E=10\mu\text{A}$ |
| Collector cutoff current | I_{CBO} | - | - | 100 | nA | $V_{CB}=15\text{V}$ |
| Emitter cutoff current | I_{EBO} | - | - | 100 | nA | $V_{EB}=6\text{V}$ |
| Collector-emitter saturation voltage | $V_{CE(sat)}$ | - | 85 | 200 | mV | $I_C/I_B=500\text{mA}/25\text{mA}$ |
| DC current gain | h_{FE} | 270 | - | 680 | - | $V_{CE}/I_C=2\text{V}/200\text{mA}$ * |
| Transition frequency | f_r | - | 400 | - | MHz | $V_{CE}=2\text{V}$, $I_E=-200\text{mA}$, $f=100\text{MHz}$ * |
| Collector output capacitance | C_{ob} | - | 12 | - | pF | $V_{CB}=10\text{V}$, $I_E=0\text{A}$, $f=1\text{MHz}$ |

* Pulsed

Transistors

●Electrical characteristic curves

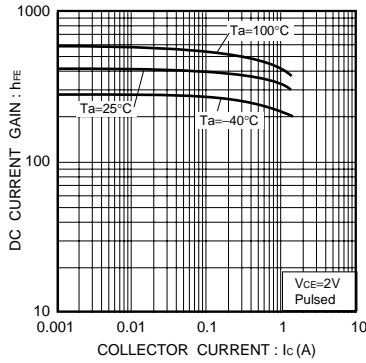

Fig.1 DC current gain vs. collector current

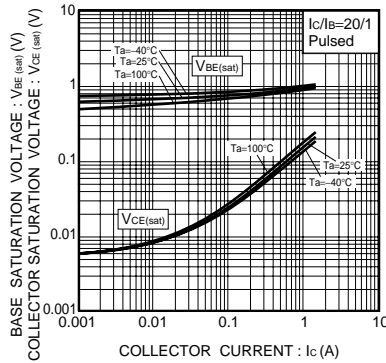

Fig.2 Collector-emitter saturation voltage base-emitter saturation voltage vs. collector current

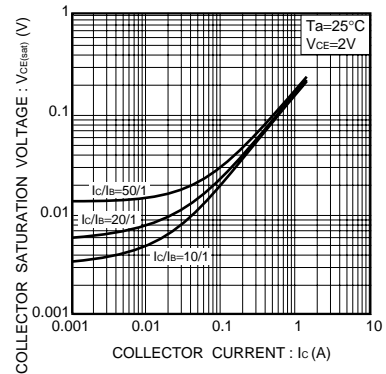

Fig.3 Collector-emitter saturation voltage vs. collector current

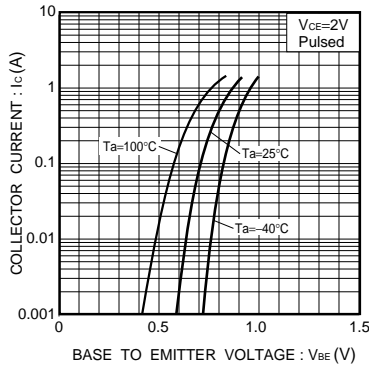

Fig.4 Grounded emitter propagation characteristics

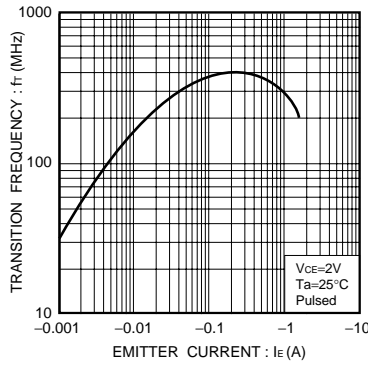

Fig.5 Gain bandwidth product vs. emitter current

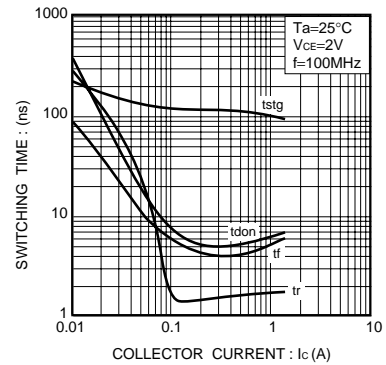

Fig.6 Switching time

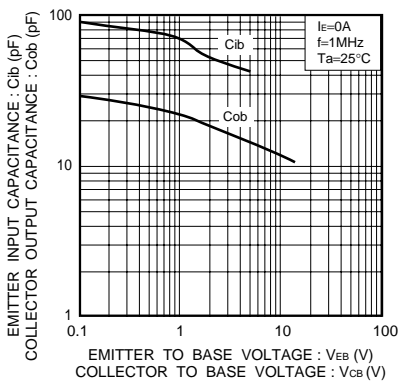

Fig.7 Collector output capacitance vs. collector-base voltage
Emitter input capacitance vs. emitter-base voltage



LittleDiode supplies new, hard to find or obsolete electronic components and semiconductors all over the world.

With over two million different components listed you are sure to find the part you need.

Feel free to visit us today at our online store:

LittleDiode.com

Looking forward to providing you with the best possible service.