

Features

- Low Deviation in Base-Emitter Voltage
- Surface Mount Package
- Ideally Suited for Automated Assembly Processes
- **Lead Free by Design/RoHS Compliant (Note 1)**
- **"Green" Device (Note 2)**
- **Qualified to AEC-Q101 Standards for High Reliability**

Mechanical Data

- Case: SOT-23
- Case material: Molded Plastic. "Green" Molding Compound. UL Flammability Classification Rating 94V-0
- Moisture Sensitivity: Level 1 per J-STD-020D
- Terminal Connections: See Diagram
- Terminals: Finish - Matte Tin annealed over Alloy 42 leadframe. Solderable per MIL-STD-202, Method 208
- Marking Information: See Page 3
- Ordering Information: See Page 3
- Weight: 0.008 grams (approximate)

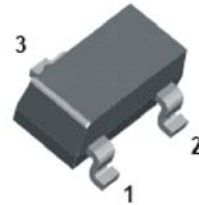

SOT-23

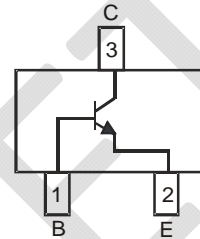

Schematic & Pin Configuration

Maximum Ratings @ $T_A = 25^\circ\text{C}$ unless otherwise specified

Characteristic	Symbol	Value	Unit
Collector-Base Voltage	V_{CB0}	50	V
Collector-Emitter Voltage	V_{CE0}	45	V
Emitter-Base Voltage	V_{EB0}	6	V
Output Current - Continuous (Note 3)	I_C	200	mA
Peak Collector Current	I_{CM}	200	mA
Peak Emitter Current	I_{EM}	200	mA
Power Dissipation (Note 3)	P_d	300	mW
Power Deration	P_{der}	2.4	mW/ $^\circ\text{C}$

Thermal Characteristics

Characteristic	Symbol	Value	Unit
Thermal Resistance, Junction to Ambient Air (Note 3)	$R_{\theta JA}$	417	$^\circ\text{C}/\text{W}$
Operating and Storage Junction Temperature Range	T_j, T_{STG}	-55 to +150	$^\circ\text{C}$

- Notes:
1. No purposefully added lead.
 2. Diode's Inc.'s "Green" policy can be found on our website at http://www.diodes.com/products/lead_free/index.php.
 3. Device mounted on FR-4 PCB, 1 inch x 0.85 inch x 0.062 inch; pad layout as shown on page 4 or on Diodes Inc. suggested pad layout document AP02001, which can be found on our website at <http://www.diodes.com/datasheets/ap02001.pdf>.

Electrical Characteristics: NPN Transistor @ $T_A = 25^\circ\text{C}$ unless otherwise specified

Characteristic	Symbol	Min	Typ	Max	Unit	Test Condition
OFF CHARACTERISTICS (Note 4)						
Collector-Base Breakdown Voltage	$V_{(BR)CBO}$	50	—	—	V	$I_C = 10\mu\text{A}, I_E = 0$
Collector-Emitter Breakdown Voltage	$V_{(BR)CEO}$	45	—	—	V	$I_C = 1.0\text{mA}, I_B = 0$
Emitter-Base Breakdown Voltage	$V_{(BR)EBO}$	6	—	—	V	$I_E = 10\mu\text{A}, I_C = 0$
Collector Cutoff Current	I_{CEX}	—	—	15	nA	$V_{CE} = 50\text{V}, V_{EB(OFF)} = 3.0\text{V}$
Base Cutoff Current (I_{BEX})	I_{BL}	—	—	15	nA	$V_{CE} = 40\text{V}, V_{EB(OFF)} = 3.0\text{V}$
Collector-Base Cut Off Current	I_{CBO}	—	—	15	nA	$V_{CB} = 40\text{V}, I_E = 0$
				5	μA	$V_{CB} = 30\text{V}, T_A = 150^\circ\text{C}$
Collector-Emitter Cut Off Current, $I_{O(OFF)}$	I_{CEO}	—	—	50	nA	$V_{CE} = 40\text{V}, I_B = 0$
Emitter-Base Cut Off Current	I_{EBO}	—	—	50	nA	$V_{EB} = 5\text{V}, I_C = 0$
ON CHARACTERISTICS (Note 4)						
DC Current Gain	h_{FE}	180	—	—	—	$V_{CE} = 5\text{V}, I_C = 100\mu\text{A}$
		150	—	—	—	$V_{CE} = 5\text{V}, I_C = 500\mu\text{A}$
		220	—	—	—	$V_{CE} = 5\text{V}, I_C = 1\text{mA}$
		220	—	—	—	$V_{CE} = 5\text{V}, I_C = 2\text{mA}$
		150	—	—	—	$V_{CE} = 5\text{V}, I_C = 5\text{mA}$
		150	—	—	—	$V_{CE} = 5\text{V}, I_C = 10\text{mA}$
Collector-Emitter Saturation Voltage	$V_{CE(SAT)}$	—	0.09	0.18	V	$I_C = 10\text{mA}, I_B = 0.5\text{mA}$
		—	0.2	0.4	V	$I_C = 100\text{mA}, I_B = 5\text{mA}$
Base-Emitter Turn-On Voltage	$V_{BE(ON)}$	647	657	667	mV	$V_{CE} = 5\text{V}, I_C = 2\text{mA}$
Base-Emitter Saturation Voltage	$V_{BE(SAT)}$	—	—	0.8	V	$I_C = 10\text{mA}, I_B = 0.5\text{mA}$
		—	—	0.9	V	$I_C = 100\text{mA}, I_B = 5\text{mA}$
SMALL SIGNAL CHARACTERISTICS						
Output Capacitance	C_{OBO}	—	3	—	pF	$V_{CB} = 5.0\text{V}, f = 1.0\text{MHz}, I_E = 0$
Input Impedance	h_{ie}	—	4.5	—	K Ω	$V_{CE} = 5.0\text{V}, I_C = 2\text{mA}, f = 1.0\text{KHz}$
Voltage Feedback Ratio	h_{re}	—	2	—	$\times 10E-4$	
Small Signal Current Gain	h_{fe}	—	200	—	—	
Output Admittance	h_{oe}	—	30	—	μS	
Current Gain-Bandwidth Product	f_T	100	—	—	MHz	$V_{CE} = 20\text{V}, I_C = 10\text{mA}, f = 100\text{MHz}$
Noise Figure	NF	—	—	10	dB	$V_{CE} = 5\text{V}, I_C = 100\mu\text{A}, R_S = 1\text{K}\Omega, f = 1\text{kHz}$

Notes: 4. Short duration pulse test used to minimize self-heating effect.

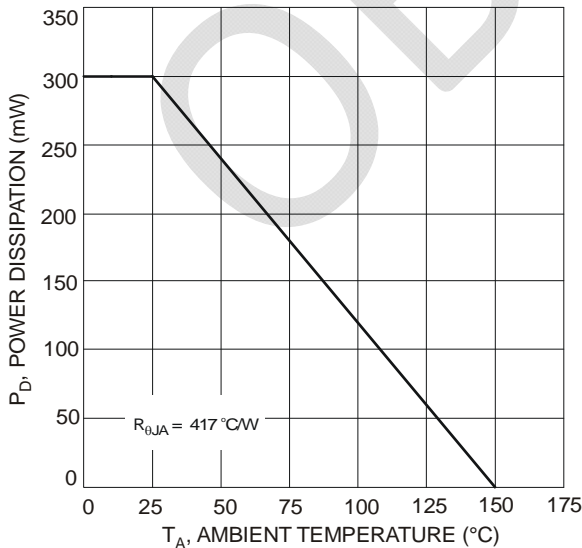

Fig. 1 Maximum Power Dissipation vs. Ambient Temperature

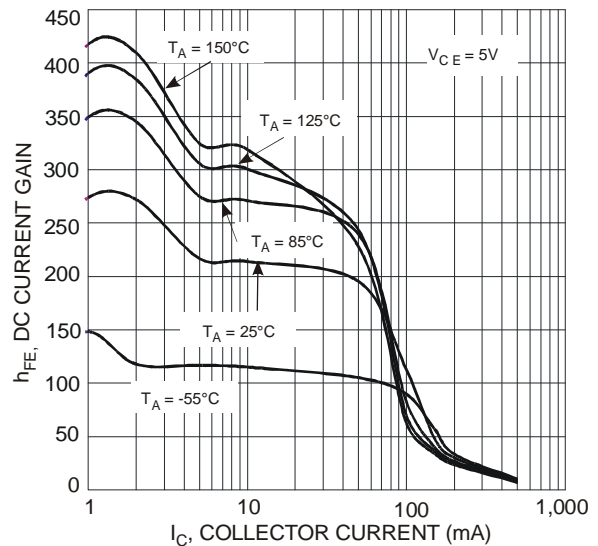

Fig. 2 Typical h_{FE} vs. I_C

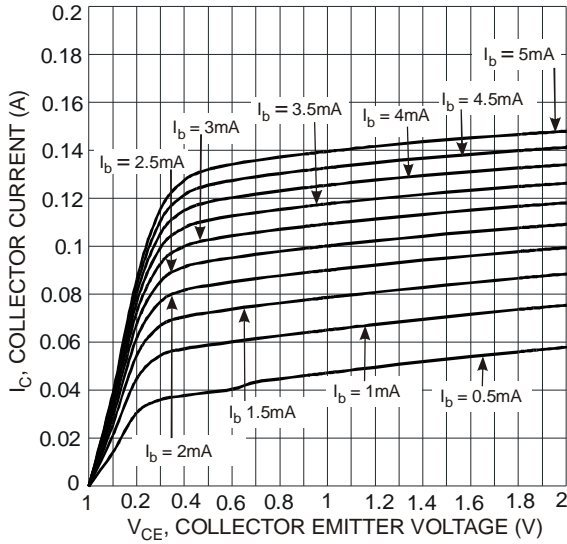

Fig. 3 Typical I_C vs. V_{CE}

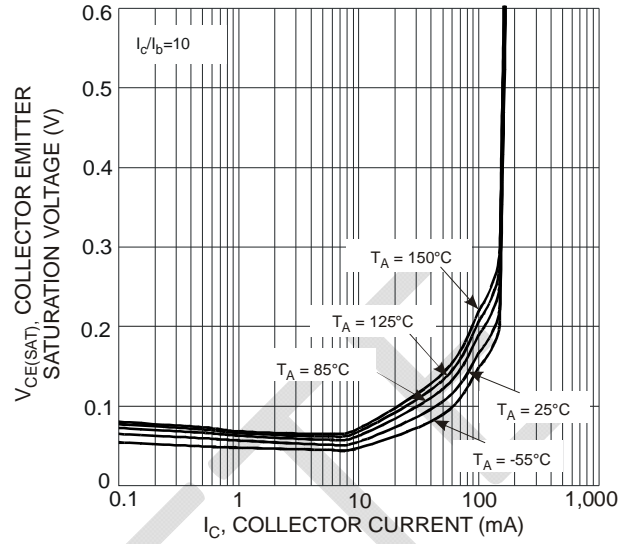

Fig. 4 Typical $V_{CE(SAT)}$ vs. I_C

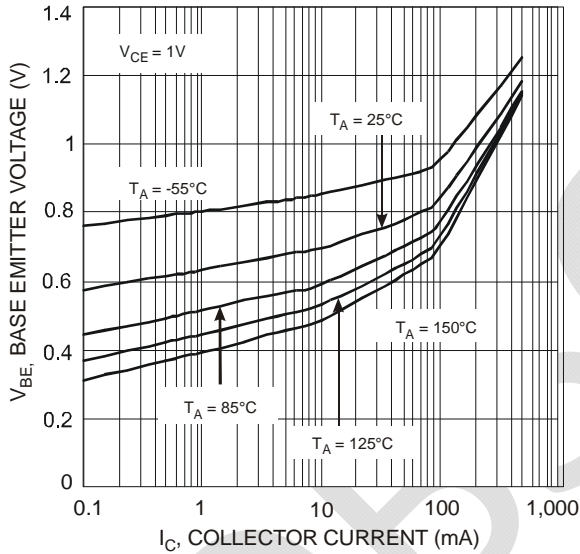

Fig. 5 Typical V_{BE} vs. I_C

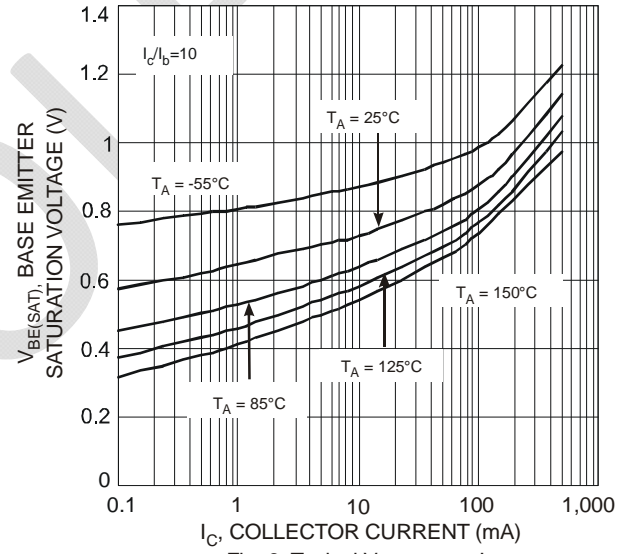

Fig. 6 Typical $V_{BE(SAT)}$ vs. I_C

Ordering Information (Note 5)

Device	Packaging	Shipping
BC847BLD-7	SOT-23	3000/Tape & Reel

Notes: 5. For packaging details, go to our website at <http://www.diodes.com/datasheets/ap02007.pdf>.

Marking Information

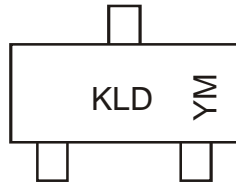

KLD = Product Type Marking Code
 YM = Date Code Marking
 Y = Year ex: T = 2006
 M = Month ex: 9 = September

Date Code Key

Year	2006	2007	2008	2009	2010	2011	2012	2013	2014	2015		
Code	T	U	V	W	X	Y	Z	A	B	C		
Month	Jan	Feb	Mar	Apr	May	Jun	Jul	Aug	Sep	Oct	Nov	Dec
Code	1	2	3	4	5	6	7	8	9	O	N	D

Mechanical Details

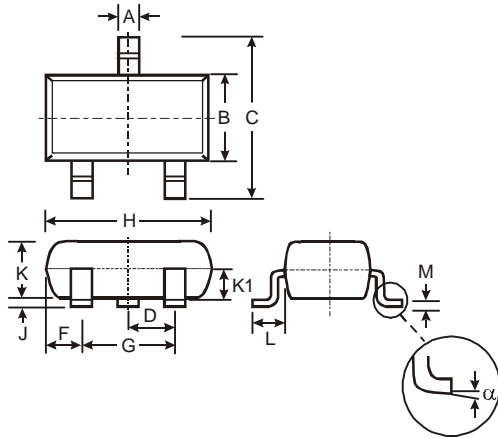

SOT-23			
Dim	Min	Max	Typ
A	0.37	0.51	0.40
B	1.20	1.40	1.30
C	2.30	2.50	2.40
D	0.89	1.03	0.915
F	0.45	0.60	0.535
G	1.78	2.05	1.83
H	2.80	3.00	2.90
J	0.013	0.10	0.05
K	0.903	1.10	1.00
K1	-	-	0.400
L	0.45	0.61	0.55
M	0.085	0.18	0.11
α	0°	8°	-

All Dimensions in mm

Suggested Pad Layout

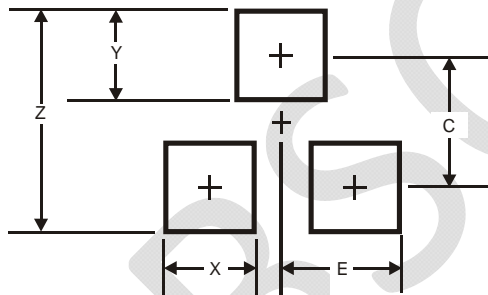

Dimensions	Value (in mm)
Z	2.9
X	0.8
Y	0.9
C	2.0
E	1.35

IMPORTANT NOTICE

DIODES INCORPORATED MAKES NO WARRANTY OF ANY KIND, EXPRESS OR IMPLIED, WITH REGARDS TO THIS DOCUMENT, INCLUDING, BUT NOT LIMITED TO, THE IMPLIED WARRANTIES OF MERCHANTABILITY AND FITNESS FOR A PARTICULAR PURPOSE (AND THEIR EQUIVALENTS UNDER THE LAWS OF ANY JURISDICTION).

Diodes Incorporated and its subsidiaries reserve the right to make modifications, enhancements, improvements, corrections or other changes without further notice to this document and any product described herein. Diodes Incorporated does not assume any liability arising out of the application or use of this document or any product described herein; neither does Diodes Incorporated convey any license under its patent or trademark rights, nor the rights of others. Any Customer or user of this document or products described herein in such applications shall assume all risks of such use and will agree to hold Diodes Incorporated and all the companies whose products are represented on Diodes Incorporated website, harmless against all damages.

Diodes Incorporated does not warrant or accept any liability whatsoever in respect of any products purchased through unauthorized sales channel. Should Customers purchase or use Diodes Incorporated products for any unintended or unauthorized application, Customers shall indemnify and hold Diodes Incorporated and its representatives harmless against all claims, damages, expenses, and attorney fees arising out of, directly or indirectly, any claim of personal injury or death associated with such unintended or unauthorized application.

Products described herein may be covered by one or more United States, international or foreign patents pending. Product names and markings noted herein may also be covered by one or more United States, international or foreign trademarks.

This document is written in English but may be translated into multiple languages for reference. Only the English version of this document is the final and determinative format released by Diodes Incorporated.

LIFE SUPPORT

Diodes Incorporated products are specifically not authorized for use as critical components in life support devices or systems without the express written approval of the Chief Executive Officer of Diodes Incorporated. As used herein:

A. Life support devices or systems are devices or systems which:

1. are intended to implant into the body, or
2. support or sustain life and whose failure to perform when properly used in accordance with instructions for use provided in the labeling can be reasonably expected to result in significant injury to the user.

B. A critical component is any component in a life support device or system whose failure to perform can be reasonably expected to cause the failure of the life support device or to affect its safety or effectiveness.

Customers represent that they have all necessary expertise in the safety and regulatory ramifications of their life support devices or systems, and acknowledge and agree that they are solely responsible for all legal, regulatory and safety-related requirements concerning their products and any use of Diodes Incorporated products in such safety-critical, life support devices or systems, notwithstanding any devices- or systems-related information or support that may be provided by Diodes Incorporated. Further, Customers must fully indemnify Diodes Incorporated and its representatives against any damages arising out of the use of Diodes Incorporated products in such safety-critical, life support devices or systems.

Copyright © 2013, Diodes Incorporated

www.diodes.com



LittleDiode supplies new, hard to find or obsolete electronic components and semiconductors all over the world.

With over two million different components listed you are sure to find the part you need.

Feel free to visit us today at our online store:

LittleDiode.com

Looking forward to providing you with the best possible service.