

CMKT2907A
ULTRAmi™
SURFACE MOUNT
DUAL PNP SILICON TRANSISTOR



Central™

Semiconductor Corp.

DESCRIPTION:

The CENTRAL SEMICONDUCTOR CMUT2907A type is a Dual PNP silicon transistor manufactured by the epitaxial planar process, epoxy molded in an ULTRAmi™ surface mount package, designed for small signal general purpose and switching applications. Marking Code is K07.

MAXIMUM RATINGS: ($T_A=25^\circ\text{C}$)

	<u>SYMBOL</u>		<u>UNITS</u>
Collector-Base Voltage	V_{CBO}	60	V
Collector-Emitter Voltage	V_{CEO}	60	V
Emitter-Base Voltage	V_{EBO}	5.0	V
Collector Current	I_C	600	mA
Power Dissipation	P_D	350	mW
Operating and Storage			
Junction Temperature	T_J, T_{stg}	-65 to +150	$^\circ\text{C}$
Thermal Resistance	Θ_{JA}	357	$^\circ\text{C/W}$

ELECTRICAL CHARACTERISTICS PER TRANSISTOR: ($T_A=25^\circ\text{C}$ unless otherwise noted)

<u>SYMBOL</u>	<u>TEST CONDITIONS</u>	<u>MIN</u>	<u>MAX</u>	<u>UNITS</u>
I_{CBO}	$V_{CB}=50\text{V}$		10	nA
I_{CBO}	$V_{CB}=50\text{V}, T_A=125^\circ\text{C}$		10	μA
I_{CEV}	$V_{CE}=30\text{V}, V_{BE}=0.5\text{V}$		50	nA
BV_{CBO}	$I_C=10\mu\text{A}$	60		V
BV_{CEO}	$I_C=10\text{mA}$	60		V
BV_{EBO}	$I_E=10\mu\text{A}$	5.0		V
$V_{CE(SAT)}$	$I_C=150\text{mA}, I_B=15\text{mA}$		0.4	V
$V_{CE(SAT)}$	$I_C=500\text{mA}, I_B=50\text{mA}$		1.6	V
$V_{BE(SAT)}$	$I_C=150\text{mA}, I_B=15\text{mA}$		1.3	V
$V_{BE(SAT)}$	$I_C=500\text{mA}, I_B=50\text{mA}$		2.6	V
h_{FE}	$V_{CE}=10\text{V}, I_C=0.1\text{mA}$	75		
h_{FE}	$V_{CE}=10\text{V}, I_C=1.0\text{mA}$	100		
h_{FE}	$V_{CE}=10\text{V}, I_C=10\text{mA}$	100		
h_{FE}	$V_{CE}=10\text{V}, I_C=150\text{mA}$	100	300	
h_{FE}	$V_{CE}=10\text{V}, I_C=500\text{mA}$	50		

ELECTRICAL CHARACTERISTICS: Continued

<u>SYMBOL</u>	<u>TEST CONDITIONS</u>	<u>MIN</u>	<u>MAX</u>	<u>UNITS</u>
f_T	$V_{CE}=20V, I_C=50mA, f=100MHz$	200		MHz
C_{ob}	$V_{CB}=10V, I_E=0, f=1.0MHz$		8.0	pF
C_{ib}	$V_{BE}=2.0V, I_C=0, f=1.0MHz$		30	pF
t_{on}	$V_{CC}=30V, V_{BE}=0.5V, I_C=150mA, I_{B1}=15mA$		45	ns
t_d	$V_{CC}=30V, V_{BE}=0.5V, I_C=150mA, I_{B1}=15mA$		10	ns
t_r	$V_{CC}=30V, V_{BE}=0.5V, I_C=150mA, I_{B1}=15mA$		40	ns
t_{off}	$V_{CC}=6.0V, I_C=150mA, I_{B1}=I_{B2}=15mA$		100	ns
t_s	$V_{CC}=6.0V, I_C=150mA, I_{B1}=I_{B2}=15mA$		80	ns
t_f	$V_{CC}=6.0V, I_C=150mA, I_{B1}=I_{B2}=15mA$		30	ns

MECHANICAL OUTLINE - SOT-363

SYMBOL	DIMENSIONS			
	INCHES		MILLIMETERS	
	MIN	MAX	MIN	MAX
A	0.073	0.085	1.85	2.15
B	0.051		1.30	
C	0.026		0.65	
D	0.075	0.091	1.90	2.30
E	0.043	0.055	1.10	1.40
F	0.006	0.012	0.15	0.30
G	0.000	0.004	0.00	0.10
H	0.010	-	0.25	-
I	0.004	0.010	0.10	0.25
J	0.031	0.039	0.80	1.00

SOT-363 (REV: R1)

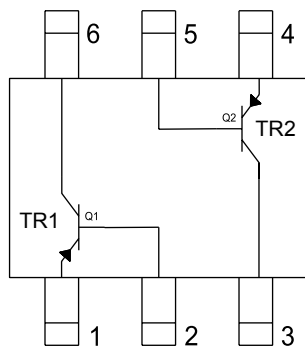
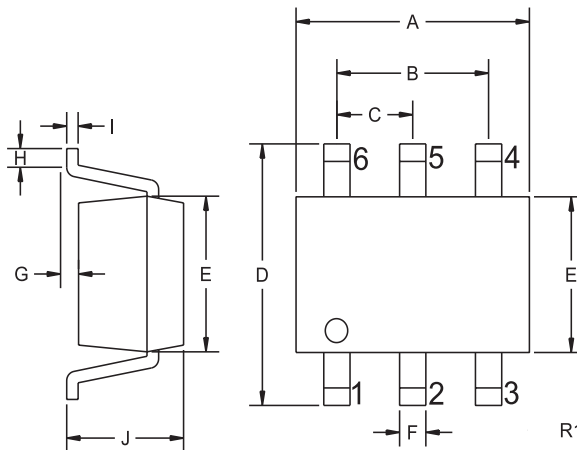

LEAD CODE:

- 1) TR1 Emitter
- 2) TR1 Base
- 3) TR2 Collector
- 4) TR2 Emitter
- 5) TR2 Base
- 6) TR1 Collector



LittleDiode supplies new, hard to find or obsolete electronic components and semiconductors all over the world.

With over two million different components listed you are sure to find the part you need.

Feel free to visit us today at our online store:

LittleDiode.com

Looking forward to providing you with the best possible service.