

CZTA77
SURFACE MOUNT
PNP SILICON
DARLINGTON TRANSISTOR

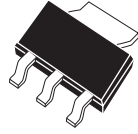

SOT-223 CASE

CentralTM

Semiconductor Corp.

DESCRIPTION:

The CENTRAL SEMICONDUCTOR CZTA77 type is a Silicon PNP Darlington Transistor manufactured by the epitaxial planar process, epoxy molded in a surface mount package, designed for applications requiring extremely high gain.

MARKING CODE: FULL PART NUMBER

MAXIMUM RATINGS: ($T_A=25^\circ\text{C}$)

	SYMBOL		UNITS
Collector-Emitter Voltage	V_{CES}	60	V
Emitter-Base Voltage	V_{EBO}	10	V
Collector Current	I_C	1.0	A
Power Dissipation	P_D	2.0	W
Operating and Storage Junction Temperature	T_J, T_{stg}	-65 to +150	$^\circ\text{C}$
Thermal Resistance	θ_{JA}	62.5	$^\circ\text{C/W}$

ELECTRICAL CHARACTERISTICS: ($T_A=25^\circ\text{C}$ unless otherwise noted)

SYMBOL	TEST CONDITIONS	MIN	MAX	UNITS
I_{CES}	$V_{CE}=50\text{V}$		500	nA
I_{CBO}	$V_{CB}=50\text{V}$		100	nA
I_{EBO}	$V_{EB}=10\text{V}$		100	nA
BV_{CES}	$I_C=100\mu\text{A}$	60		V
BV_{CBO}	$I_C=100\mu\text{A}$	60		V
$V_{CE(SAT)}$	$I_C=100\text{mA}, I_B=0.1\text{mA}$		1.5	V
$V_{BE(ON)}$	$V_{CE}=5.0\text{V}, I_C=100\text{mA}$		2.0	V
h_{FE}	$V_{CE}=5.0\text{V}, I_C=10\text{mA}$	10,000		
h_{FE}	$V_{CE}=5.0\text{V}, I_C=100\text{mA}$	10,000		
f_T	$V_{CE}=5.0\text{V}, I_C=10\text{mA}, f=100\text{MHz}$	125		MHz

SOT-223 CASE - MECHANICAL OUTLINE

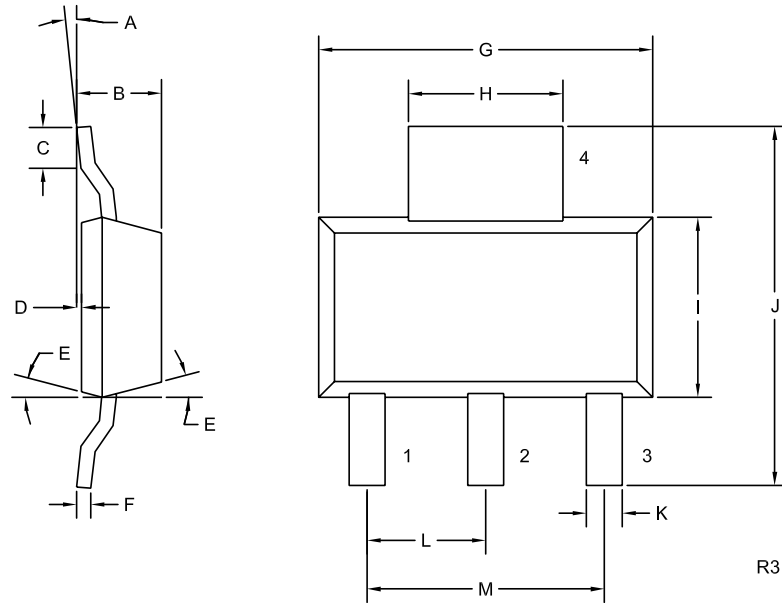

LEAD CODE:

- 1) BASE
- 2) COLLECTOR
- 3) EMITTER
- 4) COLLECTOR

MARKING CODE:
FULL PART NUMBER

SYMBOL	INCHES		MILLIMETERS	
	MIN	MAX	MIN	MAX
A	0°	10°	0°	10°
B	0.059	0.071	1.50	1.80
C	0.018	---	0.45	---
D	0.000	0.004	0.00	0.10
E	15°		15°	
F	0.009	0.014	0.23	0.35
G	0.248	0.264	6.30	6.70
H	0.114	0.122	2.90	3.10
I	0.130	0.146	3.30	3.70
J	0.264	0.287	6.70	7.30
K	0.024	0.033	0.60	0.85
L	0.091		2.30	
M	0.181		4.60	

SOT-223 (REV: R3)



LittleDiode supplies new, hard to find or obsolete electronic components and semiconductors all over the world.

With over two million different components listed you are sure to find the part you need.

Feel free to visit us today at our online store:

LittleDiode.com

Looking forward to providing you with the best possible service.