

# Digital transistors (built-in resistors)

## DTB114EK / DTB114ES

### ●Features

- 1) Built-in bias resistors enable the configuration of an inverter circuit without connecting external input resistors (see equivalent circuit).
- 2) The bias resistors consist of thin-film resistors with complete isolation to allow positive biasing of the input. They also have the advantage of almost completely eliminating parasitic effects.
- 3) Only the on/off conditions need to be set for operation, making device design easy.

### ●Structure

PNP digital transistor  
(Built-in resistor type)

### ●External dimensions (Units: mm)

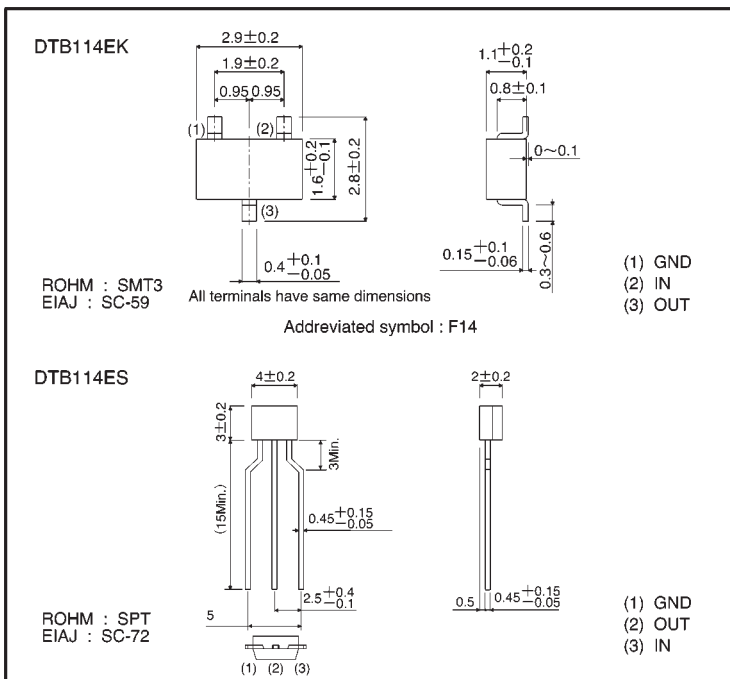

### ●Absolute maximum ratings (Ta = 25°C)

Parameter	Symbol	Limits(DTB114E□)		Unit
		K	S	
Supply voltage	V <sub>CC</sub>	-50		V
Input voltage	V <sub>IN</sub>	-40~+10		V
Output current	I <sub>C</sub>	-500		mA
Power dissipation	P <sub>d</sub>	200	300	mW
Junction temperature	T <sub>j</sub>	150		°C
Storage temperature	T <sub>stg</sub>	-55~+150		°C

### ●Equivalent circuit

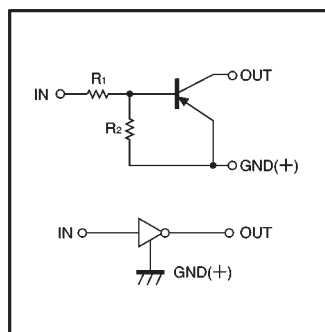

●Electrical characteristics (Ta = 25°C)

Parameter	Symbol	Min.	Typ.	Max.	Unit	Conditions
Input voltage	$V_{I(off)}$	—	—	-0.5	V	$V_{CC} = -5V, I_o = 100 \mu A$
	$V_{I(on)}$	-3	—	—		$V_o = -0.3V, I_o = -10mA$
Output voltage	$V_{O(on)}$	—	-0.1	-0.3	V	$I_o/I_i = -50mA/-2.5mA$
Input current	$I_i$	—	—	-0.88	mA	$V_i = -5V$
Output current	$I_{o(off)}$	—	—	-0.5	$\mu A$	$V_{CC} = -50V, V_i = 0V$
DC current gain	$G_i$	56	—	—	—	$V_o = -5V, I_o = -50mA$
Input resistance	$R_i$	7	10	13	k $\Omega$	—
Resistance ratio	$R_2/R_1$	0.8	1	1.2	—	—
Transition frequency	$f_T$	—	200	—	MHz	$V_{CE} = -10V, I_E = 5mA, f = 100MHz$ *

\* Transition frequency of the device

●Packaging specifications

Part No.	Package	SMT3	SPT
	Packaging type	Taping	Taping
	Code	T146	TP
	Basic ordering unit (pieces)	3000	5000
DTB114EK		○	—
DTB114ES		—	○

●Electrical characteristic curves

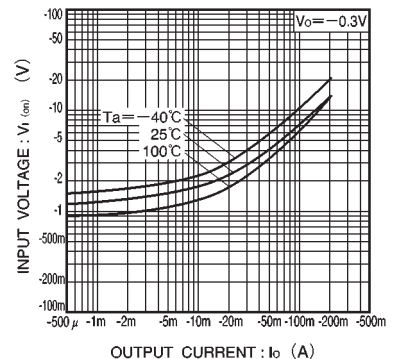

Fig.1 Input voltage vs. output current (ON characteristics)

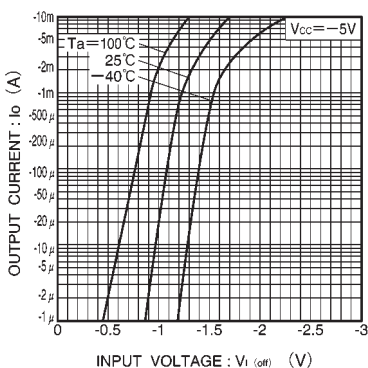

Fig.2 Output current vs. input voltage (OFF characteristics)

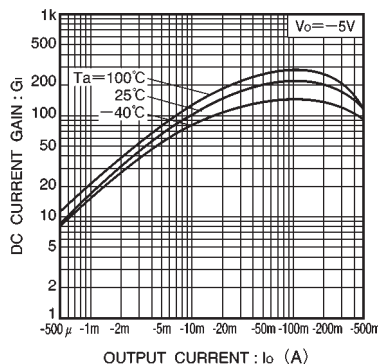

Fig.3 DC current gain vs. output current

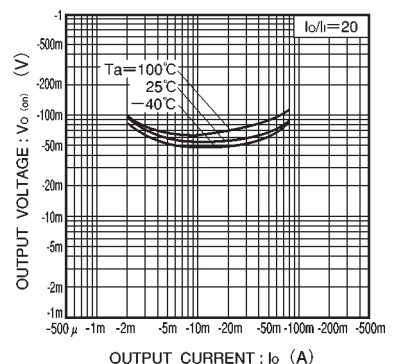

Fig.4 Output voltage vs. output current



LittleDiode supplies new, hard to find or obsolete electronic components and semiconductors all over the world.

With over two million different components listed you are sure to find the part you need.

Feel free to visit us today at our online store:

[LittleDiode.com](http://LittleDiode.com)

Looking forward to providing you with the best possible service.