

# Emitter common (dual digital transistors)

## EMG9 / UMG9N / FMG9A

●Features

- 1) Two DTC114E in a EMT or UMT or SMT package.
- 2) Mounting cost and area can be cut in half.

●Structure

Epitaxial planar type  
NPN silicon transistor  
(Built-in resistor type)

The following characteristics apply to both the DTr1 and DTr2.

●Equivalent circuit

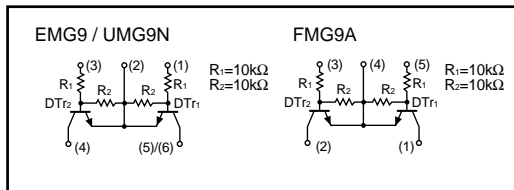

●Absolute maximum ratings (Ta = 25°C)

Parameter	Symbol	Limits	Unit
Supply voltage	V <sub>CC</sub>	50	V
Input voltage	V <sub>IN</sub>	40	V
		-10	
Output current	I <sub>o</sub>	50	mA
	I <sub>c</sub> (Max.)	100	
Power dissipation	EMG9, UMG9N	150 (TOTAL)	*1
	FMG9A	300 (TOTAL)	*2
Junction temperature	T <sub>j</sub>	150	°C
Storage temperature	T <sub>stg</sub>	-55~+150	°C

\*1 120mW per element must not be exceeded.  
\*2 200mW per element must not be exceeded.

●External dimensions (Units : mm)

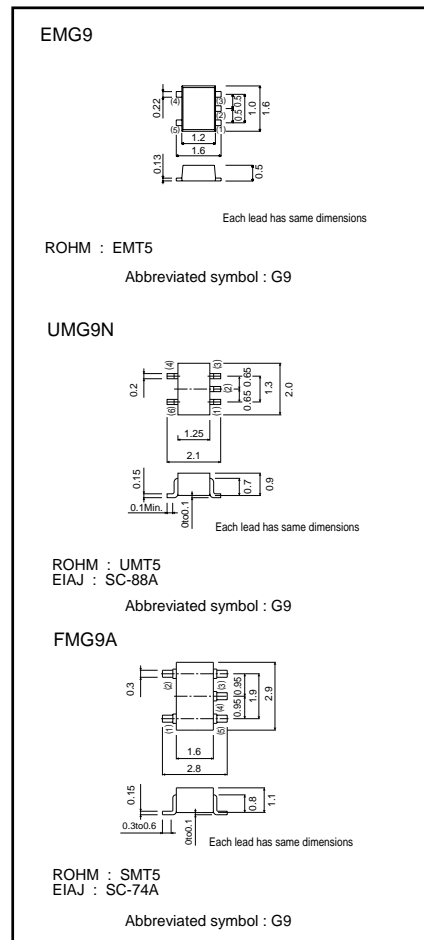

Transistors

●Electrical characteristics (Ta = 25°C)

Parameter	Symbol	Min.	Typ.	Max.	Unit	Conditions
Input voltage	$V_{I(off)}$	—	—	0.5	V	$V_{CC}=5V, I_o=100\mu A$
	$V_{I(on)}$	3	—	—		$V_o=0.3V, I_o=10mA$
Output voltage	$V_{O(on)}$	—	0.1	0.3	V	$I_o=10mA, I_i=0.5mA$
Input current	$I_i$	—	—	0.88	mA	$V_i=5V$
Output current	$I_{O(off)}$	—	—	0.5	$\mu A$	$V_{CC}=50V, V_i=0V$
DC current gain	$G_i$	30	—	—	—	$V_o=5V, I_o=5mA$
Transition frequency	$f_T$	—	250	—	MHz	$V_{CE}=10mA, I_e=-5mA, f=100MHz$ *
Input resistance	$R_i$	7	10	13	$k\Omega$	—
Resistance ratio	$R_z/R_1$	0.8	1.0	1.2	—	—

\* Transition frequency of the device

●Packaging specifications

Type	Package	Taping		
	Code	T2R	TR	T148
	Basic ordering unit (pieces)	8000	3000	3000
EMG9	○	—	—	—
UMG9N	—	○	—	—
FMG9A	—	—	—	○

●Electrical characteristic curves

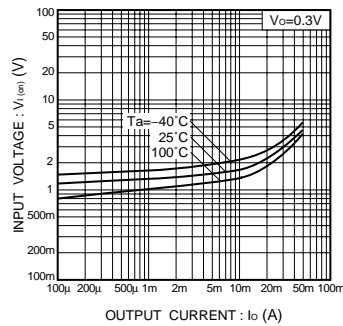

Fig.1 Input voltage vs. output current (ON characteristics)

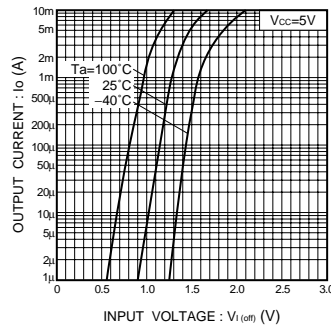

Fig.2 Output current vs. input voltage (OFF characteristics)

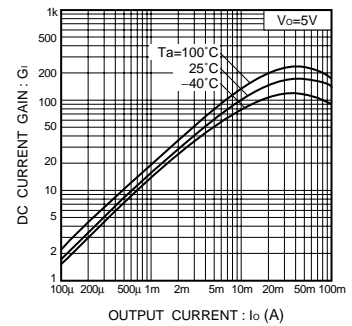

Fig.3 DC current gain vs. output current

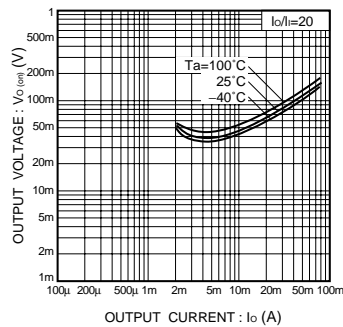

Fig.4 Output voltage vs. output current



LittleDiode supplies new, hard to find or obsolete electronic components and semiconductors all over the world.

With over two million different components listed you are sure to find the part you need.

Feel free to visit us today at our online store:

[LittleDiode.com](http://LittleDiode.com)

Looking forward to providing you with the best possible service.