

# FJP2145

## ESBC™ Rated NPN Power Transistor

### ESBC Features (FDC655 MOSFET)

$V_{CS(ON)}$	$I_C$	Equiv. $R_{CS(ON)}^{(1)}$
0.21 V	2 A	0.105 $\Omega$

- Low Equivalent On Resistance
- Very Fast Switch: 150 kHz
- Wide RBSOA: Up to 1100 V
- Avalanche Rated
- Low Driving Capacitance, No Miller Capacitance
- Low Switching Losses
- Reliable HV Switch: No False Triggering due to High dv/dt Transients

### Applications

- High-Voltage, High-Speed Power Switch
- Emitter-Switched Bipolar/MOSFET Cascode (ESBC™)
- Smart Meters, Smart Breakers, SMPS, HV Industrial Power Supplies
- Motor Drivers and Ignition Drivers

### Description

The FJP2145 is a low-cost, high-performance power switch designed to provide the best performance when used in an ESBC™ configuration in applications such as: power supplies, motor drivers, smart grid, or ignition switches. The power switch is designed to operate up to 1100 volts and up to 5 amps, while providing exceptionally low on-resistance and very low switching losses.

The ESBC™ switch can be driven using off-the-shelf power supply controllers or drivers. The ESBC™ MOSFET is a low-voltage, low-cost, surface-mount device that combines low-input capacitance and fast switching. The ESBC™ configuration further minimizes the required driving power because it does not have Miller capacitance.

The FJP2145 provides exceptional reliability and a large operating range due to its square reverse-bias-safe-operating-area (RBSOA) and rugged design. The device is avalanche rated and has no parasitic transistors, so is not prone to static dv/dt failures.

The power switch is manufactured using a dedicated high-voltage bipolar process and is packaged in a high-voltage TO-220 package.

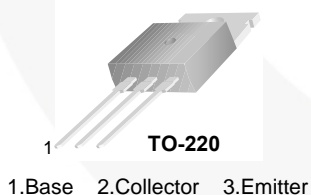


Figure 1. Pin Configuration

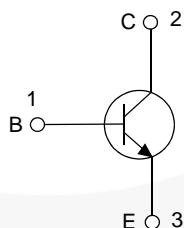


Figure 2. Internal Schematic Diagram

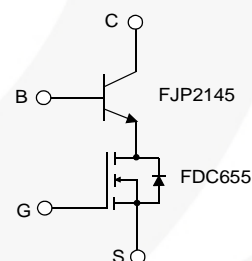


Figure 3. ESBC Configuration<sup>(2)</sup>

### Ordering Information

Part Number	Marking	Package	Packing Method
FJP2145TU	J2145	TO-220	TUBE

#### Notes:

1. Figure of Merit.
2. Other Fairchild MOSFETs can be used in this ESBC application.

## Absolute Maximum Ratings<sup>(3)</sup>

Stresses exceeding the absolute maximum ratings may damage the device. The device may not function or be operable above the recommended operating conditions and stressing the parts to these levels is not recommended. In addition, extended exposure to stresses above the recommended operating conditions may affect device reliability. The absolute maximum ratings are stress ratings only. Values are at  $T_A = 25^\circ\text{C}$  unless otherwise noted.

Symbol	Parameter	Value	Units
$V_{CBO}$	Collector-Base Voltage	1100	V
$V_{CEO}$	Collector-Emitter Voltage	800	V
$V_{EBO}$	Emitter-Base Voltage	7	V
$I_C$	Collector Current	5	A
$I_B$	Base Current	1.5	A
$P_C$	Collector Dissipation ( $T_C = 25^\circ\text{C}$ )	120	W
$T_J$	Operating and Junction Temperature Range	-55 to +125	$^\circ\text{C}$
$T_{STG}$	Storage Temperature Range	-55 to +150	$^\circ\text{C}$
$EAR^{(4)}$	Avalanche Energy ( $T_J = 25^\circ\text{C}$ , 1.2 mH)	15	mJ

### Notes:

- Pulse test is pulse width  $\leq 5$  ms, duty cycle  $\leq 10\%$ .
- Lab characterization data only for reference.

## Thermal Characteristics

Values are at  $T_A = 25^\circ\text{C}$  unless otherwise noted.

Symbol	Parameter	Max.	Units
$R_{\theta JC}$	Thermal Resistance, Junction to Case	1.04	$^\circ\text{C}/\text{W}$
$R_{\theta JA}$	Thermal Resistance, Junction to Ambient	78.72	$^\circ\text{C}/\text{W}$

## Electrical Characteristics<sup>(5)</sup>

Values are at  $T_A = 25^\circ\text{C}$  unless otherwise noted.

Symbol	Parameter	Test Condition	Min.	Typ.	Max.	Units
$BV_{CBO}$	Collector-Base Breakdown Voltage	$I_C = 1$ mA, $I_E = 0$	1100			V
$BV_{CEO}$	Collector-Emitter Breakdown Voltage	$I_C = 5$ mA, $I_B = 0$	800			V
$BV_{EBO}$	Emitter-Base Breakdown Voltage	$I_E = 1$ mA, $I_C = 0$	7			V
$I_{CBO}$	Collector Cut-off Current	$V_{CB} = 800$ V, $I_E = 0$			10	$\mu\text{A}$
$I_{EBO}$	Emitter Cut-off Current	$V_{EB} = 5$ V, $I_C = 0$			10	$\mu\text{A}$
$h_{FE1}$	DC Current Gain	$V_{CE} = 5$ V, $I_C = 0.2$ A	20		40	
$h_{FE2}$		$V_{CE} = 5$ V, $I_C = 1$ A	8			
$V_{CE(sat)}$	Collector-Emitter Saturation Voltage	$I_C = 0.25$ A, $I_B = 0.05$ A		0.049		V
		$I_C = 0.5$ A, $I_B = 0.167$ A		0.052		V
		$I_C = 1$ A, $I_B = 0.33$ A		0.082		V
		$I_C = 1.5$ A, $I_B = 0.3$ A		0.151	2.000	V
$V_{BE(sat)}$	Base-Emitter Saturation Voltage	$I_C = 500$ mA, $I_B = 50$ mA		0.752		V
		$I_C = 1.5$ A, $I_B = 0.3$ A		0.833	1.500	V
		$I_C = 2$ A, $I_B = 0.4$ A		0.855		V
$C_{IB}$	Input Capacitance	$V_{EB} = 5$ V, $I_C = 0$ , $f = 1$ MHz		1.618		pF
$C_{OB}$	Output Capacitance	$V_{CB} = 200$ V, $I_E = 0$ , $f = 1$ MHz		11.39		pF
$f_T$	Current Gain Bandwidth Product	$V_{CE} = 10$ V, $I_C = 0.2$ A		15		MHz

### Note:

- Pulse test is pulse width  $\leq 5$  ms, duty cycle  $\leq 10\%$ .

## ESBC-Configured Electrical Characteristics<sup>(6)</sup>

Values are at  $T_A = 25^\circ\text{C}$  unless otherwise noted.

Symbol	Parameter	Test Condition	Min.	Typ.	Max.	Units
$f_T$	Current Gain Bandwidth Product	$I_C = 0.1\text{ A}, V_{CE} = 10\text{ V}$		28.40		MHz
$t_f$	Inductive Current Fall Time	$V_{CC} = 100\text{ V}, V_{GS} = 10\text{ V}, R_G = 4\text{ }7\Omega,$ $V_{Clamp} = 500\text{ V}, I_C = 0.5\text{ A},$ $I_B = 0.05\text{ A}, h_{FE} = 10, L_C = 166\text{ }\mu\text{H},$ $SRF = 684\text{ kHz}$		95		ns
$t_s$	Inductive Storage Time			0.13		ns
$V_{tf}$	Inductive Voltage Fall Time			135		ns
$V_{tr}$	Inductive Voltage Rise Time			80		ns
$t_c$	Inductive Crossover Time			115		ns
$t_f$	Inductive Current Fall Time	$V_{CC} = 100\text{ V}, V_{GS} = 10\text{ V}, R_G = 47\text{ }\Omega,$ $V_{Clamp} = 500\text{ V}, I_C = 1\text{ A},$ $I_B = 0.2\text{ A}, h_{FE} = 5, L_C = 166\text{ }\mu\text{H},$ $SRF = 684\text{ kHz}$		50		ns
$t_s$	Inductive Storage Time			0.34		ns
$V_{tf}$	Inductive Voltage Fall Time			150		ns
$V_{tr}$	Inductive Voltage Rise Time			60		ns
$t_c$	Inductive Crossover Time			95		ns
$V_{CSW}$	Maximum Collector-Source Voltage at Turn-off without Snubber	$h_{FE} = 5, I_C = 2\text{ A}$	1100			V
$I_{GS(OS)}$	Gate-Source Leakage Current	$V_{GS} = \pm 20\text{ V}$		1		nA
$V_{CS(ON)}$	Collector-Source On Voltage	$V_{GS} = 10\text{ V}, I_C = 2\text{ A}, I_B = 0.67\text{ A}, h_{FE} = 3$		0.202		V
		$V_{GS} = 10\text{ V}, I_C = 1\text{ A}, I_B = 0.33\text{ A}, h_{FE} = 3$		0.111		V
		$V_{GS} = 10\text{ V}, I_C = 0.5\text{ A}, I_B = 0.17\text{ A}, h_{FE} = 3$		0.067		V
		$V_{GS} = 10\text{ V}, I_C = 0.3\text{ A}, I_B = 0.06\text{ A}, h_{FE} = 5$		0.060		V
$V_{GS(th)}$	Gate Threshold Voltage	$V_{BS} = V_{GS}, I_B = 250\text{ }\mu\text{A}$		1.9		V
$C_{iss}$	Input Capacitance ( $V_{GS} = V_{CB} = 0$ )	$V_{CS} = 25\text{ V}, f = 1\text{ MHz}$		470		pF
$Q_{GS(tot)}$	Gate-Source Change $V_{CB} = 0$	$V_{GS} = 10\text{ V}, I_C = 6.3\text{ A}, V_{CS} = 25\text{ V}$		9		nC
$R_{DS(ON)}$	Static Drain-to-Source On Resistance	$V_{GS} = 10\text{ V}, I_D = 6.3\text{ A}$		21		m $\Omega$
		$V_{GS} = 4.5\text{ V}, I_D = 5.5\text{ A}$		26		m $\Omega$
		$V_{GS} = 10\text{ V}, I_D = 6.3\text{ A}, T_J = 125^\circ\text{C}$		30		m $\Omega$

### Note:

6. A typical FDC655 MOSFET was used for the specifications above. Values could vary if other Fairchild MOSFETs are used.

## Typical Performance Characteristics

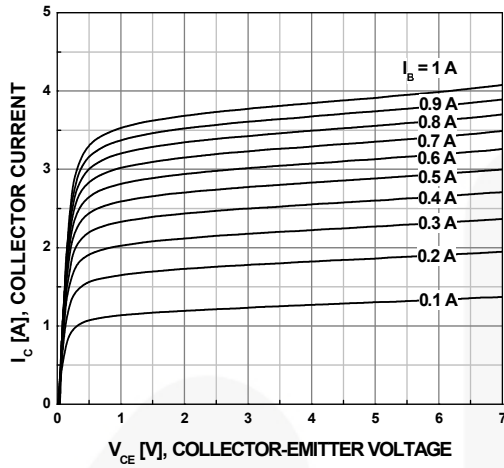


Figure 4. Static Characteristics

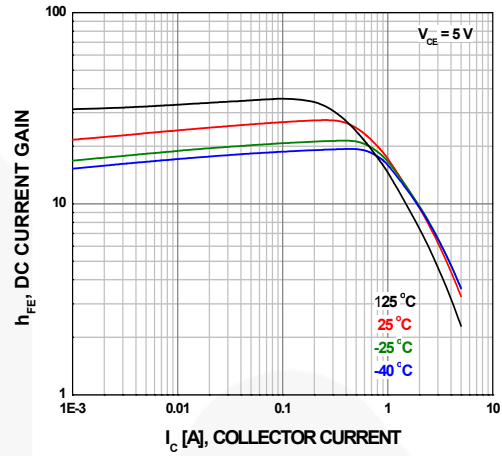


Figure 5. DC Current Gain

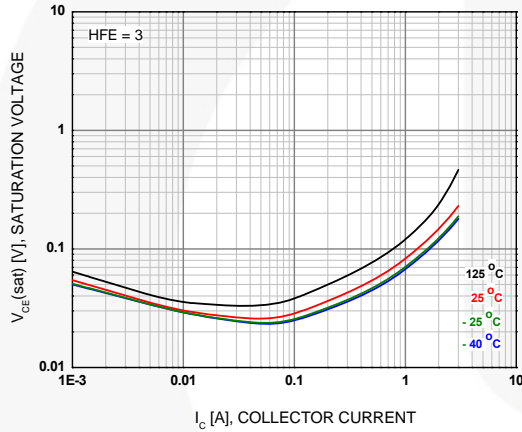


Figure 6. Collector-Emitter Saturation Voltage  
 $h_{FE} = 3$

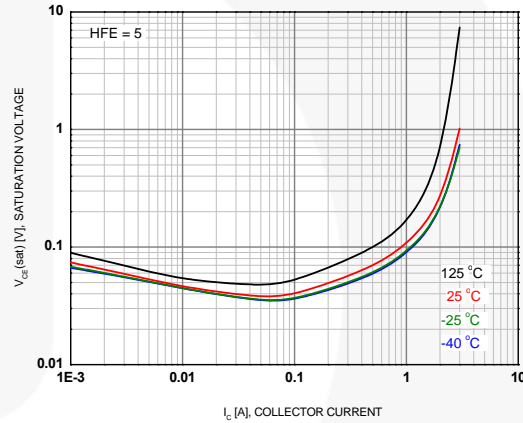


Figure 7. Collector-Emitter Saturation Voltage  
 $h_{FE} = 5$

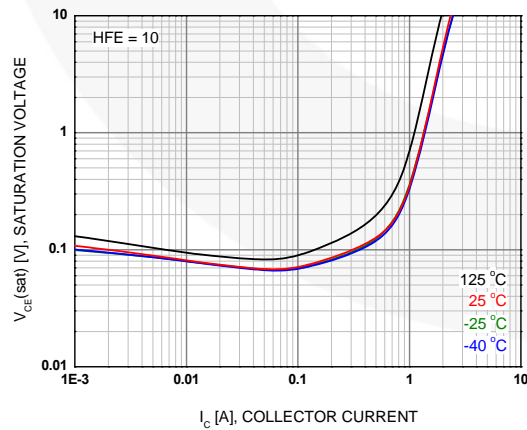


Figure 8. Collector-Emitter Saturation Voltage  
 $h_{FE} = 10$

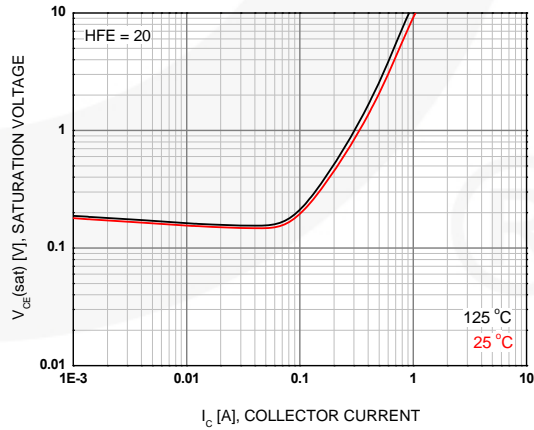
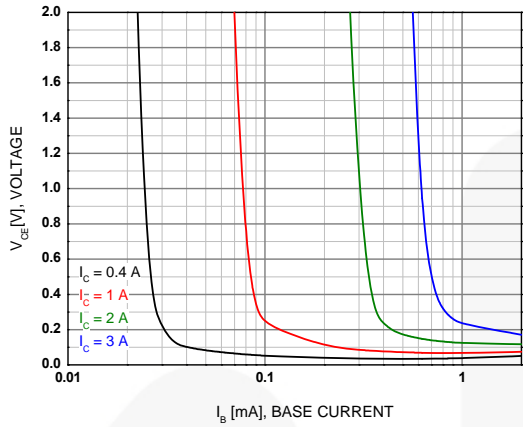
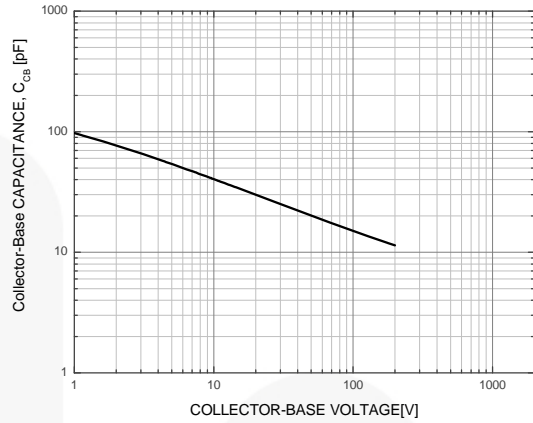


Figure 9. Collector-Emitter Saturation Voltage  
 $h_{FE} = 20$

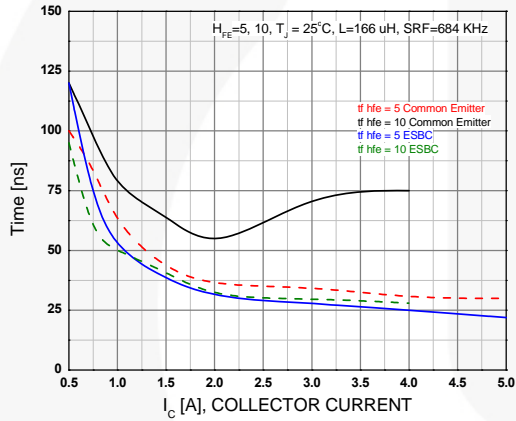
## Typical Performance Characteristics (Continued)



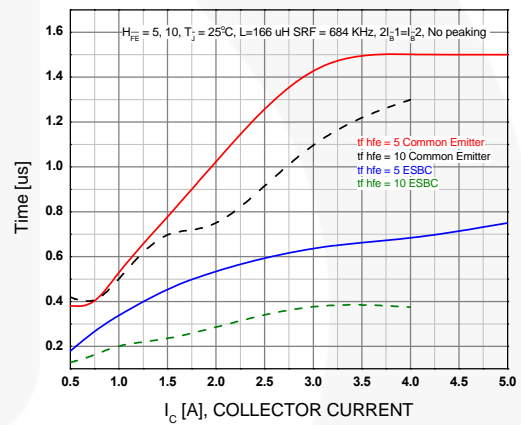
**Figure 10. Typical Collector Saturation Voltage**



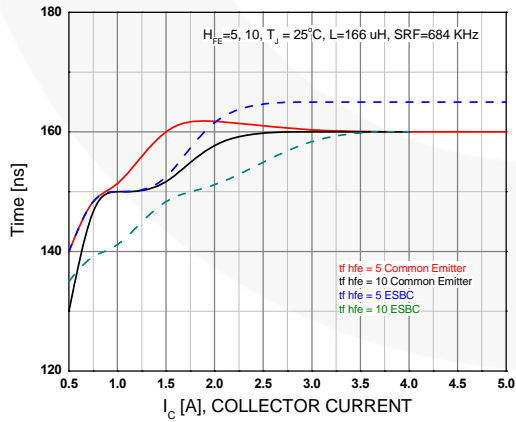
**Figure 11. Capacitance**



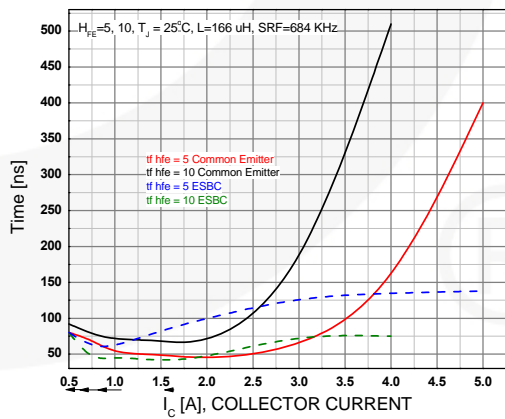
**Figure 12. Inductive Load Collector Current Fall - Time ( $t_f$ )**



**Figure 13. Inductive Load Collector Current Storage - Time ( $t_{stg}$ )**

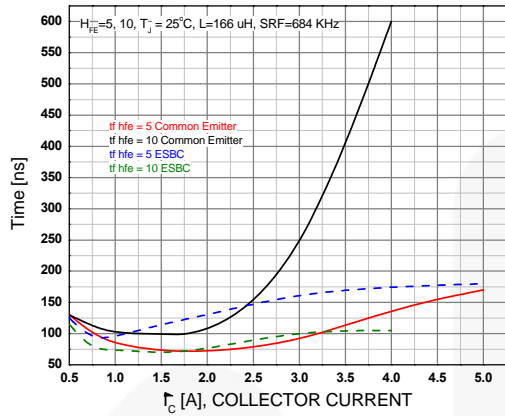


**Figure 14. Inductive Load Collector Voltage Fall - Time ( $t_f$ )**

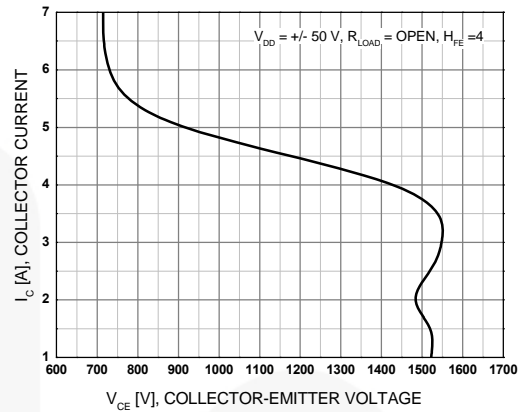


**Figure 15. Inductive Load Collector Voltage Rise - Time ( $t_r$ )**

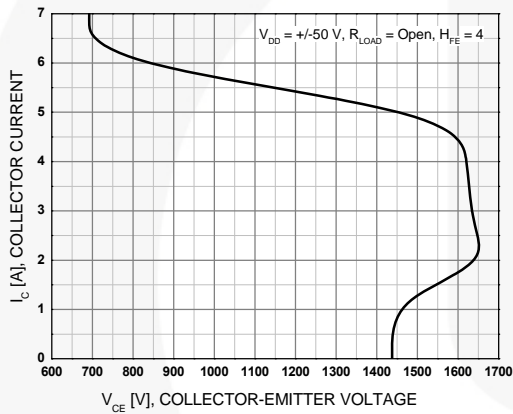
**Typical Performance Characteristics (Continued)**



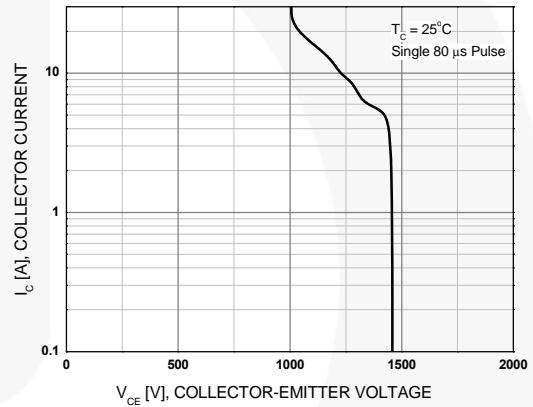
**Figure 16. Inductive Load Collector Current / Voltage Crossover ( $t_c$ )**



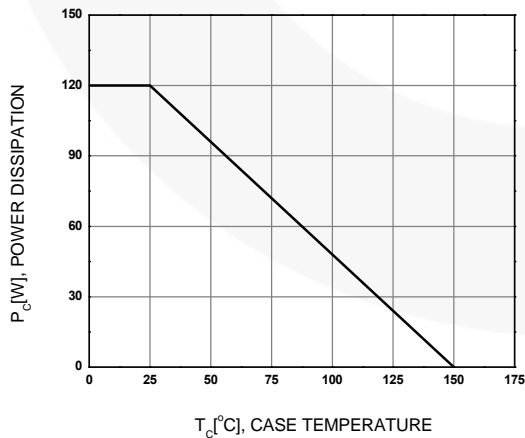
**Figure 17. BJT RBSOA**



**Figure 18. ESBC RBSOA**

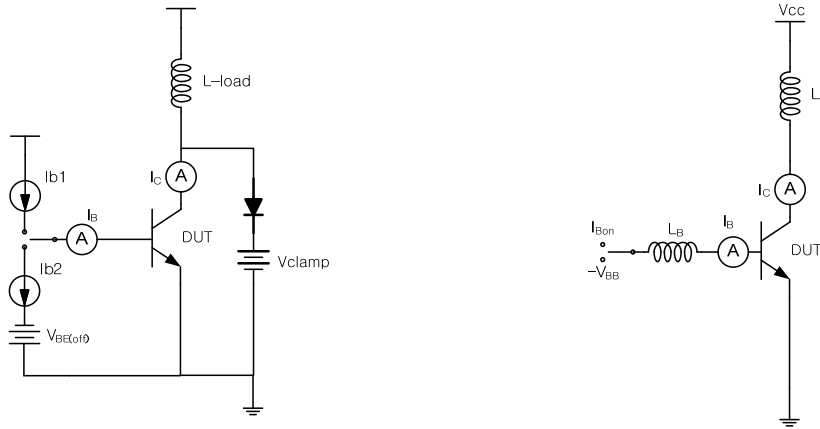


**Figure 19. Crossover FBSOA**

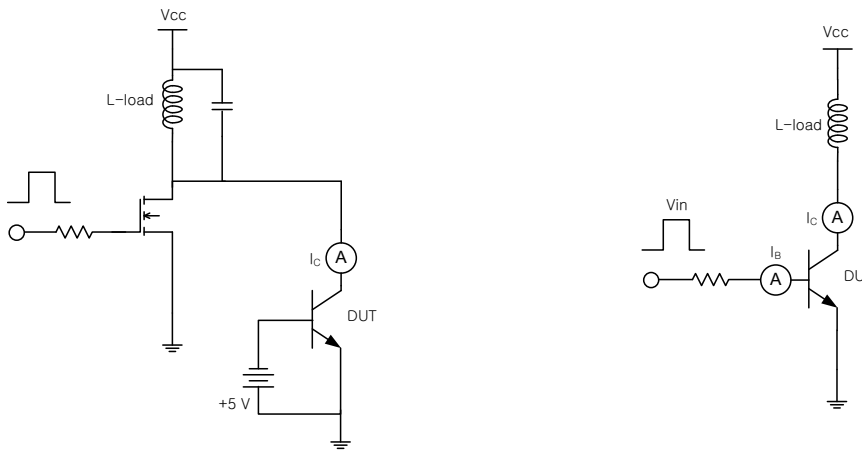


**Figure 20. Power Derating**

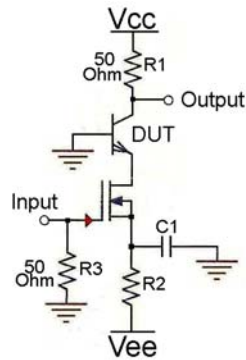
**Test Circuits**



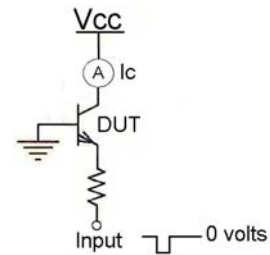
**Figure 21. Test Circuit For Inductive Load and Reverse Bias Safe Operating**



**Figure 22. Energy Rating Test Circuit**



**Figure 23. Ft Measurement**



**Figure 24. FBSOA**

Test Circuits (Continued)

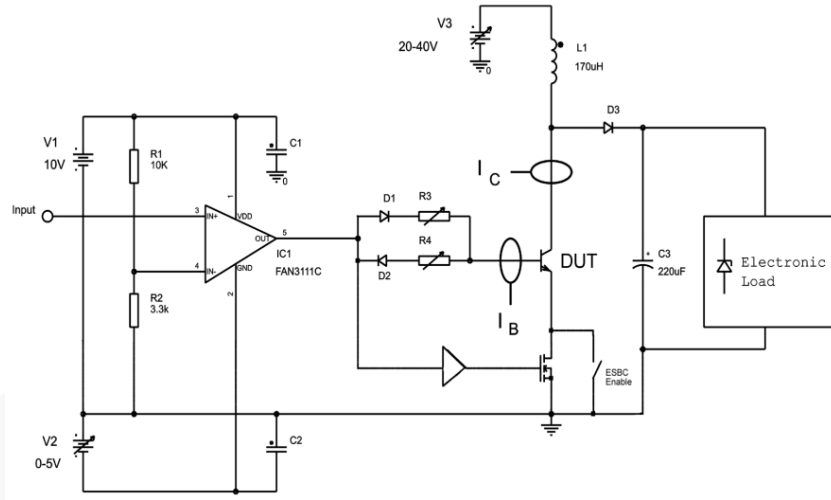


Figure 25. Simplified Saturated Switch Driver Circuit

Functional Test Waveforms

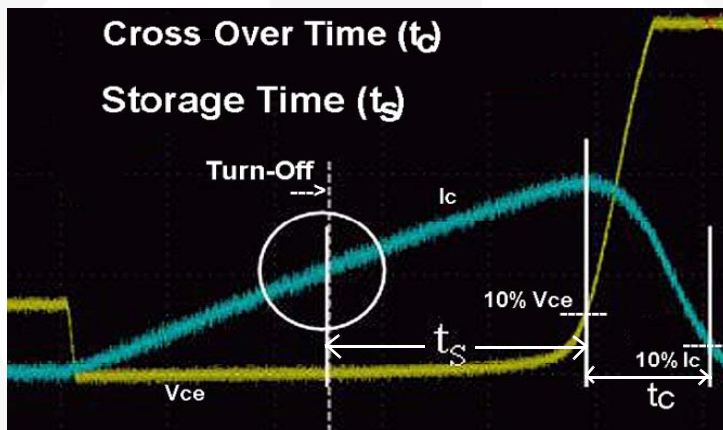


Figure 26. Crossover Time Measurement

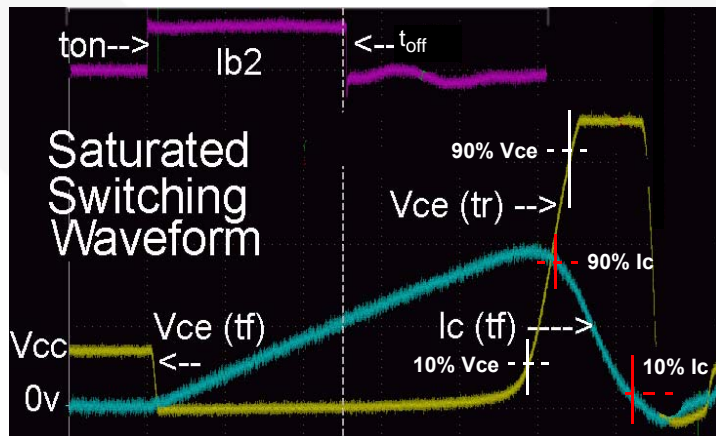


Figure 27. Saturated Switching Waveform

Functional Test Waveforms (Continued)

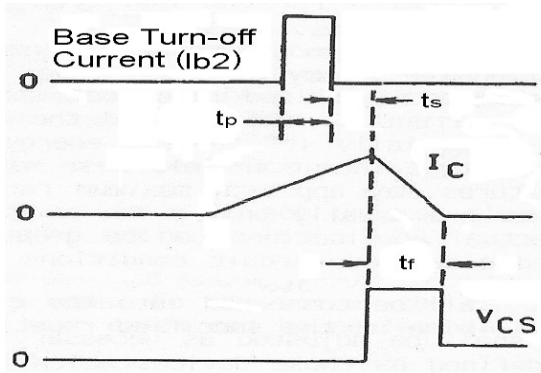


Figure 28. Storage Time - Common Emitter Base Turn Off ( $I_{b2}$ ) to  $I_C$  Fall - Time

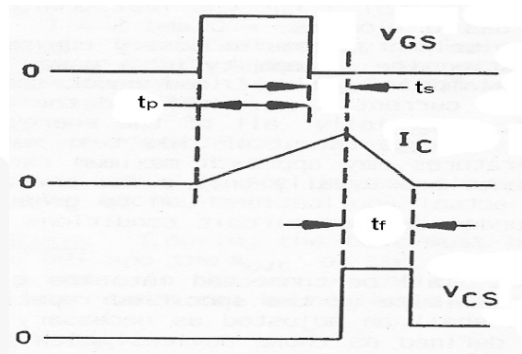
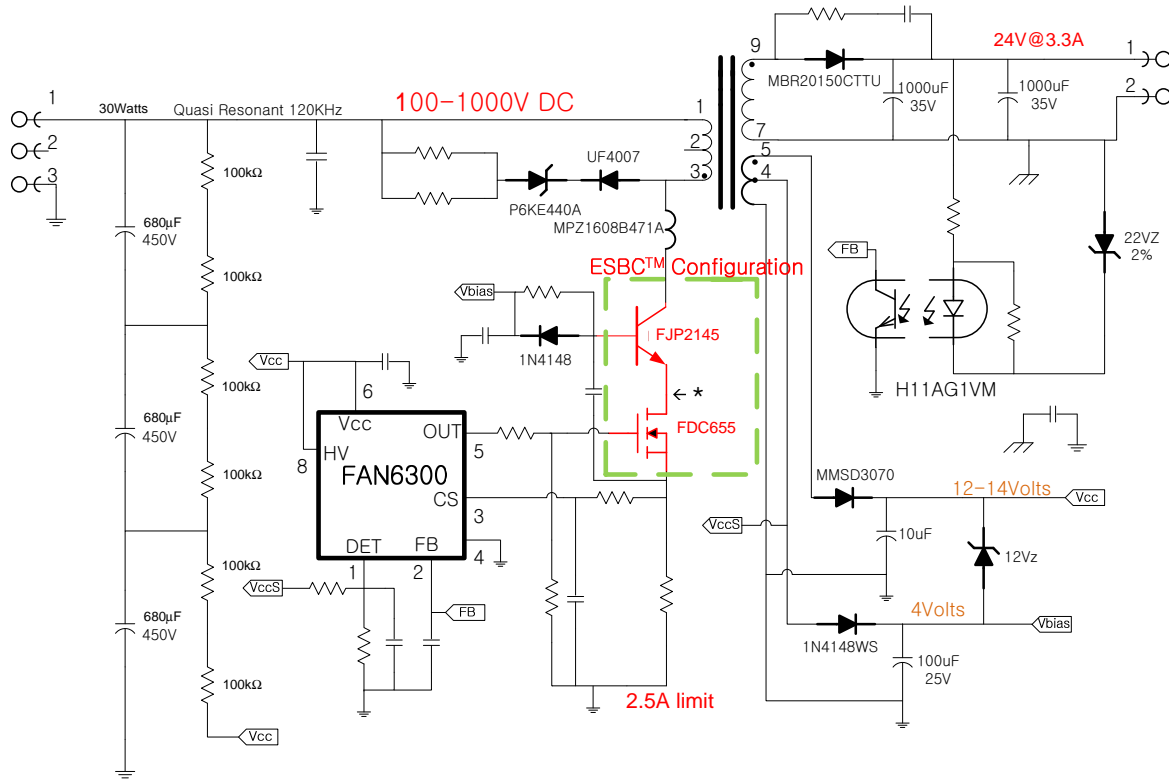


Figure 29. Storage Time - ESBC FET Gate (Off) to  $I_C$  Fall - Time

## Very Wide Input Voltage Range Supply



\* Make short as possible

Figure 30. 30 W; Secondary-Side Regulation: 3 Capacitor Input; Quasi Resonant

## Driving ESBC Switches

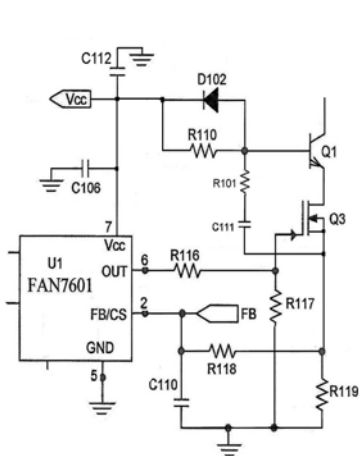


Figure 31. V<sub>CC</sub> Derived

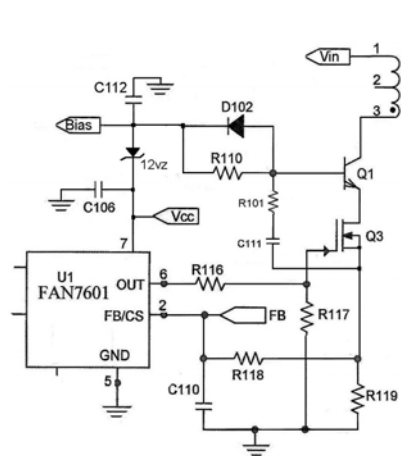


Figure 32. V<sub>BIAS</sub> Supply Derived

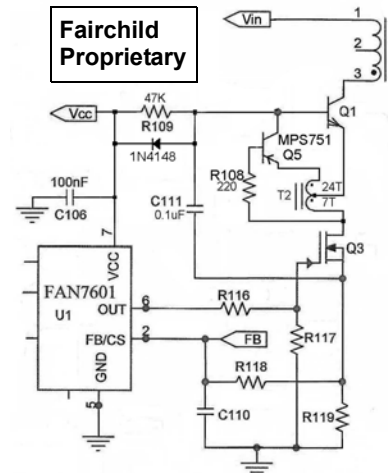
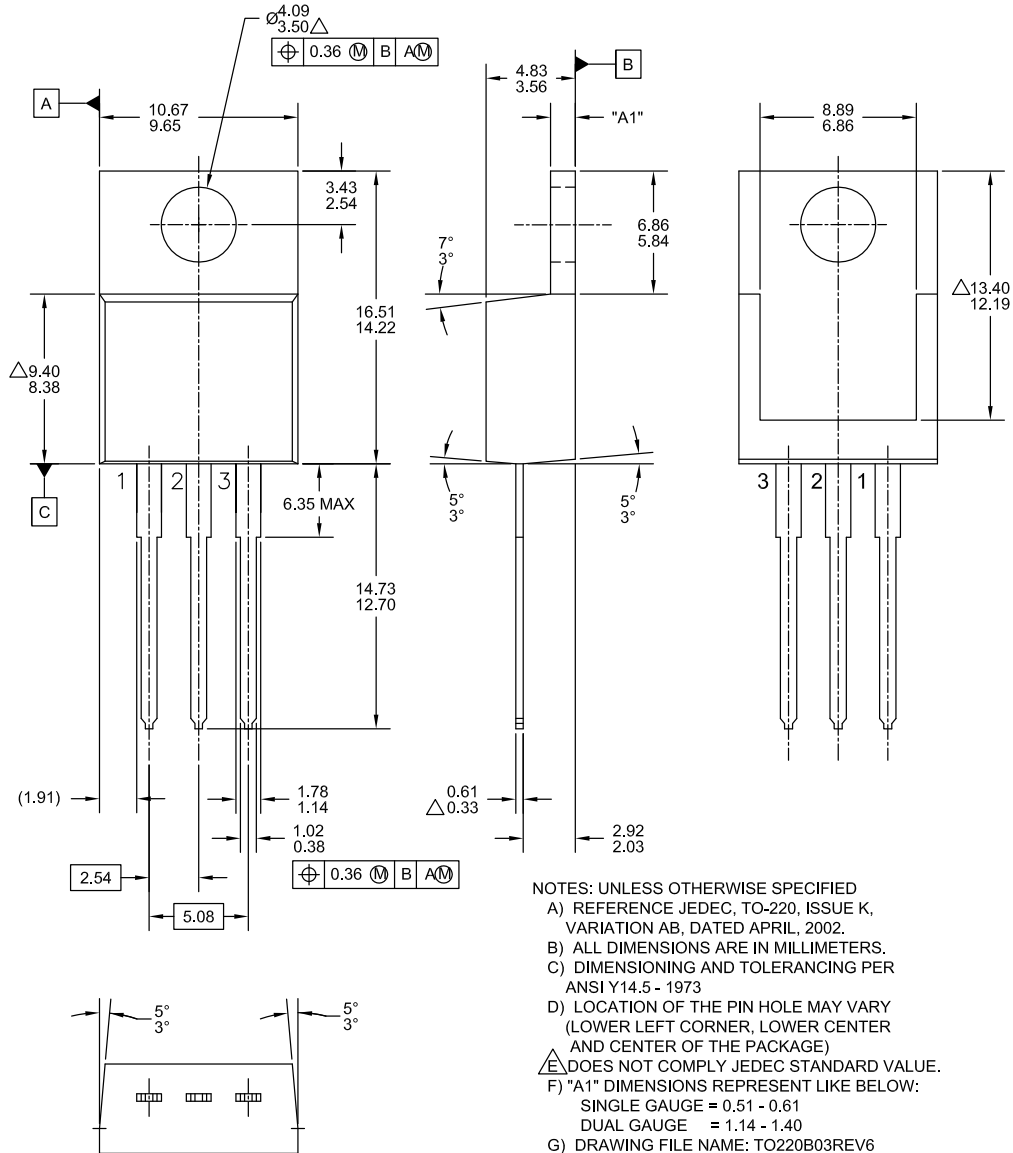


Figure 33. Proportional Drive

## Physical Dimensions

### TO-220



**Figure 34. TO-220, MOLDED, 3-LEAD, JEDEC VARIATION AB**

Package drawings are provided as a service to customers considering Fairchild components. Drawings may change in any manner without notice. Please note the revision and/or date on the drawing and contact a Fairchild Semiconductor representative to verify or obtain the most recent revision. Package specifications do not expand the terms of Fairchild's worldwide terms and conditions, specifically the warranty therein, which covers Fairchild products.

Always visit Fairchild Semiconductor's online packaging area for the most recent package drawings:

<http://www.fairchildsemi.com/packaging/>


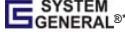



For current tape and reel specifications, visit Fairchild Semiconductor's online packaging area:

<http://www.fairchildsemi.com/dwg/TO/TO220B03.pdf>



**TRADEMARKS**

The following includes registered and unregistered trademarks and service marks, owned by Fairchild Semiconductor and/or its global subsidiaries, and is not intended to be an exhaustive list of all such trademarks.

- |   |  |   |   |
|---|--|---|---|
| 2Cool™  | FPS™   |  | Sync-Lock™  |
| AccuPower™  | F-PFS™   | PowerTrench®  |  |
| AX-CAP®*  | FRFET®   | PowerXS™  | TinyBoost™  |
| BitSiC™   | Global Power Resource <sup>SM</sup>            | Programmable Active Droop™  | TinyBuck™   |
| Build it Now™   | GreenBridge™                                   | QFET®   | TinyCalc™   |
| CorePLUS™   | Green FPS™                                     | QS™   | TinyLogic®  |
| CorePOWER™  | Green FPS™ e-Series™                           | Quiet Series™   | TINYOPTO™   |
| CROSSVOLT™  | Gmax™  | RapidConfigure™   | TinyPower™  |
| CTL™  | GTO™   |  | TinyPWM™  |
| Current Transfer Logic™   | IntelliMAX™                                    | Saving our world, 1mW/W/kW at a time™   | TinyWire™   |
| DEUXPEED®   | ISOPLANAR™                                     | SignalWise™   | TranSiC™  |
| Dual Cool™  | Making Small Speakers Sound Louder and Better™ | SmartMax™   | TriFault Detect™  |
| EcoSPARK®   | MegaBuck™                                      | SMART START™  | TRUECURRENT®*   |
| EfficientMax™   | MICROCOUPLER™                                  | Solutions for Your Success™   | μSerDes™  |
| ESBC™   | MicroFET™                                      | SPM®  |  |
|  | MicroPak™                                      | STEALTH™  | UHC®  |
| Fairchild®  | MicroPak2™                                     | SuperFET®   | Ultra FRFET™  |
| Fairchild Semiconductor®  | MillerDrive™                                   | SuperSOT™-3   | UniFET™   |
| FACT Quiet Series™  | MotionMax™                                     | SuperSOT™-6   | VCX™  |
| FACT®   | mWSaver™                                       | SuperSOT™-8   | VisualMax™  |
| FAST®   | OptoHiT™                                       | SupreMOS®   | VoltagePlus™  |
| FastvCore™  | OPTOLOGIC®                                     | SyncFET™  | XS™   |
| FETBench™   | OPTOPLANAR®                                    |   |   |

\* Trademarks of System General Corporation, used under license by Fairchild Semiconductor.

**DISCLAIMER**

FAIRCHILD SEMICONDUCTOR RESERVES THE RIGHT TO MAKE CHANGES WITHOUT FURTHER NOTICE TO ANY PRODUCTS HEREIN TO IMPROVE RELIABILITY, FUNCTION, OR DESIGN. FAIRCHILD DOES NOT ASSUME ANY LIABILITY ARISING OUT OF THE APPLICATION OR USE OF ANY PRODUCT OR CIRCUIT DESCRIBED HEREIN; NEITHER DOES IT CONVEY ANY LICENSE UNDER ITS PATENT RIGHTS, NOR THE RIGHTS OF OTHERS. THESE SPECIFICATIONS DO NOT EXPAND THE TERMS OF FAIRCHILD'S WORLDWIDE TERMS AND CONDITIONS, SPECIFICALLY THE WARRANTY THEREIN, WHICH COVERS THESE PRODUCTS.

**LIFE SUPPORT POLICY**

FAIRCHILD'S PRODUCTS ARE NOT AUTHORIZED FOR USE AS CRITICAL COMPONENTS IN LIFE SUPPORT DEVICES OR SYSTEMS WITHOUT THE EXPRESS WRITTEN APPROVAL OF FAIRCHILD SEMICONDUCTOR CORPORATION.

As used herein:

1. Life support devices or systems are devices or systems which, (a) are intended for surgical implant into the body or (b) support or sustain life, and (c) whose failure to perform when properly used in accordance with instructions for use provided in the labeling, can be reasonably expected to result in a significant injury of the user.
2. A critical component in any component of a life support, device, or system whose failure to perform can be reasonably expected to cause the failure of the life support device or system, or to affect its safety or effectiveness.

**ANTI-COUNTERFEITING POLICY**

Fairchild Semiconductor Corporation's Anti-Counterfeiting Policy. Fairchild's Anti-Counterfeiting Policy is also stated on our external website, [www.fairchildsemi.com](http://www.fairchildsemi.com), under Sales Support.

Counterfeiting of semiconductor parts is a growing problem in the industry. All manufacturers of semiconductor products are experiencing counterfeiting of their parts. Customers who inadvertently purchase counterfeit parts experience many problems such as loss of brand reputation, substandard performance, failed applications, and increased cost of production and manufacturing delays. Fairchild is taking strong measures to protect ourselves and our customers from the proliferation of counterfeit parts. Fairchild strongly encourages customers to purchase Fairchild parts either directly from Fairchild or from Authorized Fairchild Distributors who are listed by country on our web page cited above. Products customers buy either from Fairchild directly or from Authorized Fairchild Distributors are genuine parts, have full traceability, meet Fairchild's quality standards for handling and storage and provide access to Fairchild's full range of up-to-date technical and product information. Fairchild and our Authorized Distributors will stand behind all warranties and will appropriately address any warranty issues that may arise. Fairchild will not provide any warranty coverage or other assistance for parts bought from Unauthorized Sources. Fairchild is committed to combat this global problem and encourage our customers to do their part in stopping this practice by buying direct or from authorized distributors.

**PRODUCT STATUS DEFINITIONS**

**Definition of Terms**

Datasheet Identification	Product Status	Definition
Advance Information	Formative / In Design	Datasheet contains the design specifications for product development. Specifications may change in any manner without notice.
Preliminary	First Production	Datasheet contains preliminary data; supplementary data will be published at a later date. Fairchild Semiconductor reserves the right to make changes at any time without notice to improve design.
No Identification Needed	Full Production	Datasheet contains final specifications. Fairchild Semiconductor reserves the right to make changes at any time without notice to improve the design.
Obsolete	Not In Production	Datasheet contains specifications on a product that is discontinued by Fairchild Semiconductor. The datasheet is for reference information only.

Rev. I64



LittleDiode supplies new, hard to find or obsolete electronic components and semiconductors all over the world.

With over two million different components listed you are sure to find the part you need.

Feel free to visit us today at our online store:

[LittleDiode.com](http://LittleDiode.com)

Looking forward to providing you with the best possible service.