

November 1996

Automatic Picture Tube Bias Control Circuit

Features

- Automatic Picture Tube Bias Cutoff Control
- Automatic Background Color Balance
- Eliminates Grey Scale Adjustments
- Compensates for Cathode-to-Heater Leakage
- Electrostatic Protection on All Pins
- Servo Loop Design
- Wide Dynamic Range
- Three-Gun Control
- Minimal External Components

Ordering Information

PART NUMBER	TEMP. RANGE (°C)	PACKAGE	PKG. NO.
CA3224E	-40 to 85	22 Ld PDIP	E22.4

Description

The CA3224E is an automatic picture tube bias control circuit used in color TV receiver CRT drive circuits. It is used to provide dynamic bias control of the grey scale both initially and over the CRT operating life, compensating for CRT cut-off changes.

The CA3224E provides automatic continuous control of the cutoff current in each gun of a three-gun color CRT. From an input pulse amplitude proportional to the difference between the desired and the actual CRT cutoff, a gated sample/hold circuit generates a DC correction voltage which correctly biases the CRT driver circuit. The sample/hold bias correction takes place each frame following the vertical blanking. Figure 1 shows a block diagram of the CA3224E. The functions include three identical servo loop transconductance amplifiers with a sample/hold switch and buffer amplifier plus control logic, internal bias and a mode switch.

Pinout

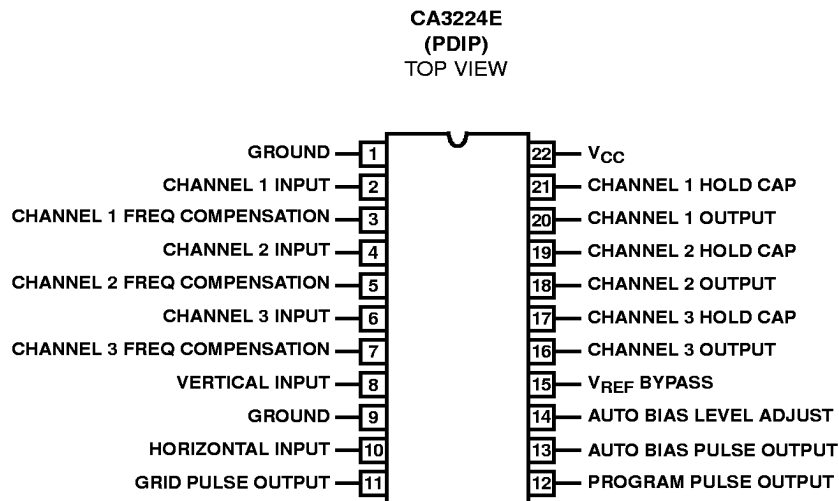

CA3224E

Absolute Maximum Ratings $T_A = 25^\circ\text{C}$

Supply Voltage (V_{CC}) 11V
 DC Input Voltage -1 to V_{CC}
 Output Current Short Circuit Protected

Thermal Information

Thermal Resistance (Typical, Note 1) θ_{JA} ($^\circ\text{C}/\text{W}$)
 PDIP Package 77
 Maximum Junction Temperature (Plastic Package) 150°C
 Maximum Storage Temperature Range -65°C to 150°C
 Maximum Lead Temperature (Soldering 10s) 300°C

Operating Conditions

Temperature Range -40°C to 85°C
 Supply Voltage Range (Typical) $10\text{V} \pm 10\%$

CAUTION: Stresses above those listed in "Absolute Maximum Ratings" may cause permanent damage to the device. This is a stress only rating and operation of the device at these or any other conditions above those indicated in the operational sections of this specification is not implied.

NOTE:

- θ_{JA} is measured with the component mounted on an evaluation PC board in free air.

Electrical Specifications At $T_A = 25^\circ\text{C}$, $V_{CC} = 10\text{V}$, $V_{BIAS} = 3.75\text{V}$, V_V (Pin 8) = V_H (Pin 10) = 6.0V , $S_1 = A$, $S_2 = A$, See Test Circuit and Timing Diagrams

PARAMETER		TEST PIN NO.	SYMBOL	TEST CONDITIONS	MIN	TYP	MAX	UNITS
Supply Current		22	I_{CC}		-	-	65	mA
Reference Voltage		2, 4, 6	V_{REF}	Measure at t_4	5.6	6.0	6.4	V
Input Current		2, 4, 6	I_I	$V_{IN} = 7.2\text{V}$, $S_1 = B$	-	-	250	nA
Output Current	Source	17, 19, 21	I_{OM+}	$V_{BIAS} = 0.5\text{V}$, Measure at t_6 , $S_1 = B$	-	-	-0.8	mA
	Sink		I_{OM-}	$V_{BIAS} = 7.0\text{V}$, Measure at t_6 , $S_1 = B$	0.8	-	-	mA
Output Buffer	Input Current	17, 19, 21	I_I	$V_{OUT} = 6.5\text{V}$, V_{IN} At pins 16, 18, 20, Measure at t_4 , $S_1 = B$	-	-	150	nA
	Voltage Gain		A_V		0.97	-	1.07	-
Transconductance		17, 19, 21	g_M	Measure at t_6 , $V_{IN} = 8\text{mV}_{p-p}$ at 40kHz, $S_1 = B$	50	-	100	mS
Auto Bias Pulse	Output Low	13	V_{OL}	Measure at t_1	-	-	0.3	V
	High		V_{OH}	Measure at t_4	6.05	-	-	V
	Current Sink		I_{OM-}	Measure at t_4 , $S_2 = B$	2.5	-	-	mA
Grid Pulse Output	Low	11	V_{OL}	Measure at t_4	-	-	0.4	V
	High		V_{OH}	Measure at t_1	4.2	-	-	V
Program Pulse Output	Low	12	V_{OL}	Measure at t_6	-	-	0.4	V
	High		V_{OH}	Measure at t_1	8.2	-	-	V
Vertical Input		8	V_V	See Figure 3	-	6.0	-	V
Horizontal Input		10	V_H	See Figure 3	-	6.0	-	V
Auto Bias Pulse Timing	Start	13		t_0 to t_2 , Note 2	835	-	842	μs
	Finish			t_0 to t_7 , Note 2	1270	-	1275	μs
Grid Pulse Timing	Start	11		t_0 to t_3 , Note 2	899	-	905	μs
	Finish			t_0 to t_5 , Note 2	1080	-	1084	μs
Program Pulse Timing	Start	12		t_0 to t_5 , Note 2	1080	-	1084	μs
	Finish			t_0 to t_7 , Note 2	1270	-	1275	μs

NOTE:

- All time measurements are made from 50% point to 50% point.

Test Circuit

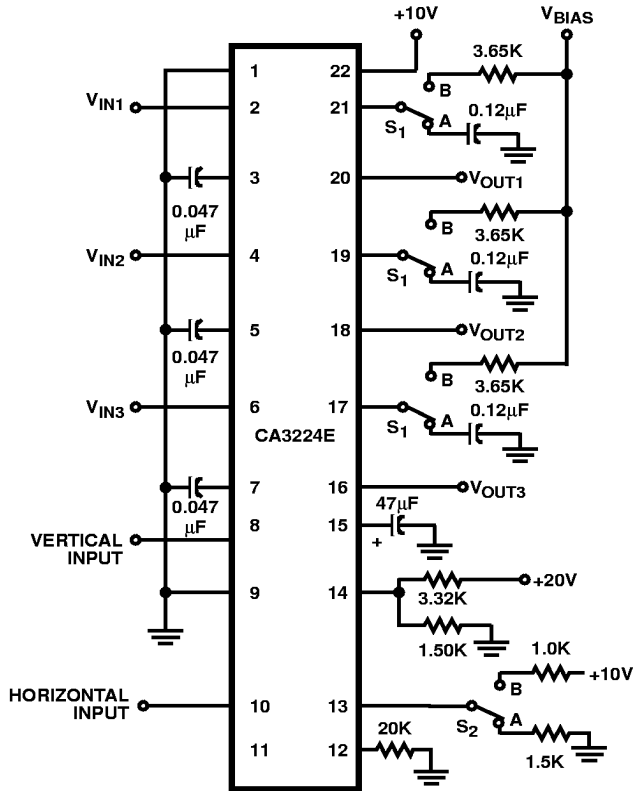

Device Description and Operation

(See Figures 1, 2, 4 and 5)

During the vertical retrace interval, 13 horizontal sync pulses are counted. On the 14th sync pulse the auto-bias pulse output goes high. This is used to set the RGB drive of the companion chroma/luma circuit to black level. The auto-bias pulse stays high for 7 horizontal periods during the auto-bias cycle.

On the 15th horizontal sync pulse, the internal logic initiates the setup interval. During the setup interval, the cathode current is increased to a reference value (A in Figure 5) through the action of the grid pulse. The cathode current causes a voltage drop across R_S . This voltage drop, together with the program pulse output results in a reference voltage at V_S (summing point) which causes capacitor C_1 to charge to a voltage proportional to the reference cathode current. The setup interval lasts for 3 horizontal periods.

On the 18th horizontal sync pulse the grid pulse output goes high, which through the grid pulse amplifier/inverter, causes the cathode current to decrease. The decrease in cathode current results in a positive recovered voltage pulse with respect to the setup reference level at the V_S summing point. The positive recovered voltage pulse is summed with a negative voltage pulse caused by the program pulse output going low (cutting off Diode D_1 and switching in resistors R_1 and R_2). Any difference between the positive and negative pulses is fed through capacitor C_1 to the transconductance amplifier. The difference signal is amplified in the transconductance amplifier and charges the hold capacitor C_2 , which, through the buffer amplifier, adjusts the bias on the driver circuit.

Components R_S , R_1 , and R_2 must be chosen such that the program pulse and the recovered pulse just cancel at the desired cathode cutoff level.

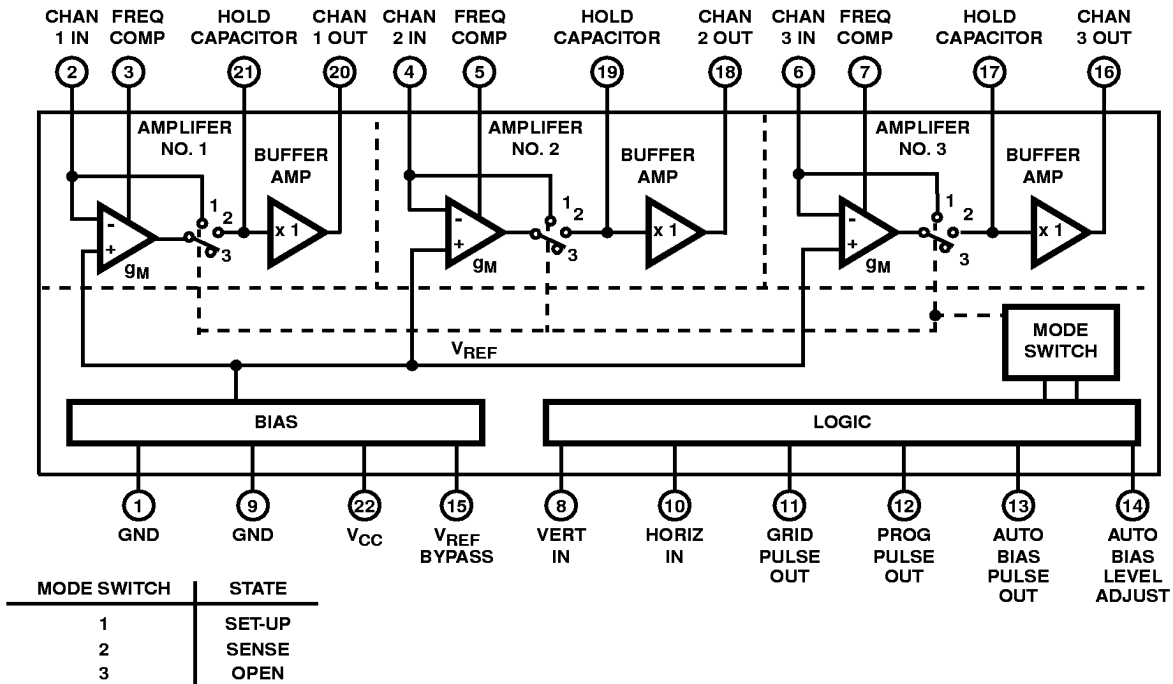

FIGURE 1. FUNCTIONAL BLOCK DIAGRAM

CA3224E

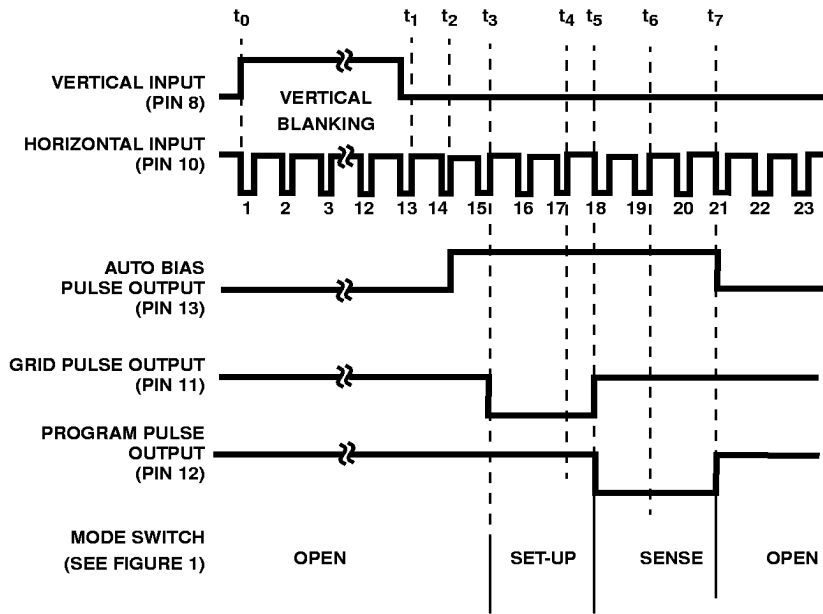

FIGURE 2. FUNCTIONAL TIMING DIAGRAMS

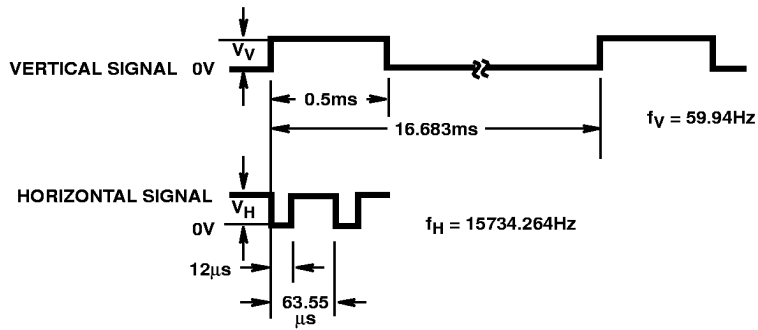

FIGURE 3. VERTICAL AND HORIZONTAL INPUT SIGNALS

