

Features

- CMOS Low Power with SOS Speed (Typ)..... 150mW
- Parallel Conversion Technique
- 15MHz Sampling Rate (Conversion Time)..... 67ns
- 8-Bit Latched Three-State Output with Overflow Bit
- Accuracy (Typ)..... ± 1 LSB
- Single Supply Voltage..... 4V to 7.5V
- 2 Units in Series Allow 9-Bit Output
- 2 Units in Parallel Allow 30MHz Sampling Rate

Applications

- TV Video Digitizing (Industrial/Security/Broadcast)
- High Speed A/D Conversion
- Ultrasound Signature Analysis
- Transient Signal Analysis
- High Energy Physics Research
- General-Purpose Hybrid ADCs
- Optical Character Recognition
- Radar Pulse Analysis
- Motion Signature Analysis
- μ P Data Acquisition Systems

Description

The CA3318 is a CMOS parallel (FLASH) analog-to-digital converter designed for applications demanding both low power consumption and high speed digitization.

The CA3318 operates over a wide full scale input voltage range of 4V up to 7.5V with maximum power consumption depending upon the clock frequency selected. When operated from a 5V supply at a clock frequency of 15MHz, the typical power consumption of the CA3318 is 150mW.

The intrinsic high conversion rate makes the CA3318 ideally suited for digitizing high speed signals. The overflow bit makes possible the connection of two or more CA3318s in series to increase the resolution of the conversion system. A series connection of two CA3318s may be used to produce a 9-bit high speed converter. Operation of two CA3318s in parallel doubles the conversion speed (i.e., increases the sampling rate from 15MHz to 30MHz).

256 paralleled auto balanced voltage comparators measure the input voltage with respect to a known reference to produce the parallel bit outputs in the CA3318.

255 comparators are required to quantize all input voltage levels in this 8-bit converter, and the additional comparator is required for the overflow bit.

Ordering Information

PART NUMBER	LINEARITY (INL, DNL)	SAMPLING RATE	TEMP. RANGE (°C)	PACKAGE	PKG. NO.
CA3318CE	± 1.5 LSB	15MHz (67ns)	-40 to 85	24 Ld PDIP	E24.6
CA3318CM	± 1.5 LSB	15MHz (67ns)	-40 to 85	24 Ld SOIC	M24.3
CA3318CD	± 1.5 LSB	15MHz (67ns)	-40 to 85	24 Ld SBDIP	D24.6

Pinout

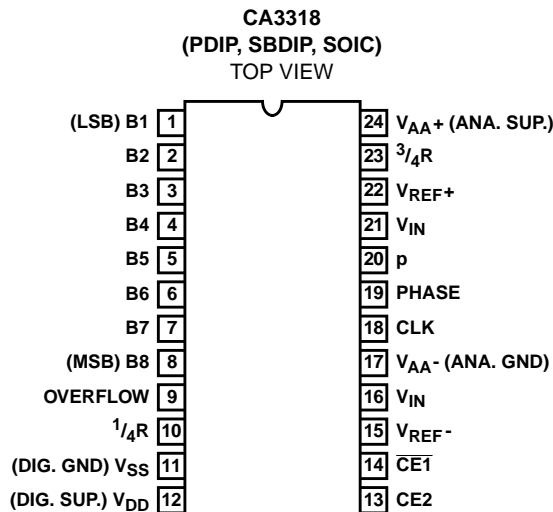

Functional Block Diagram

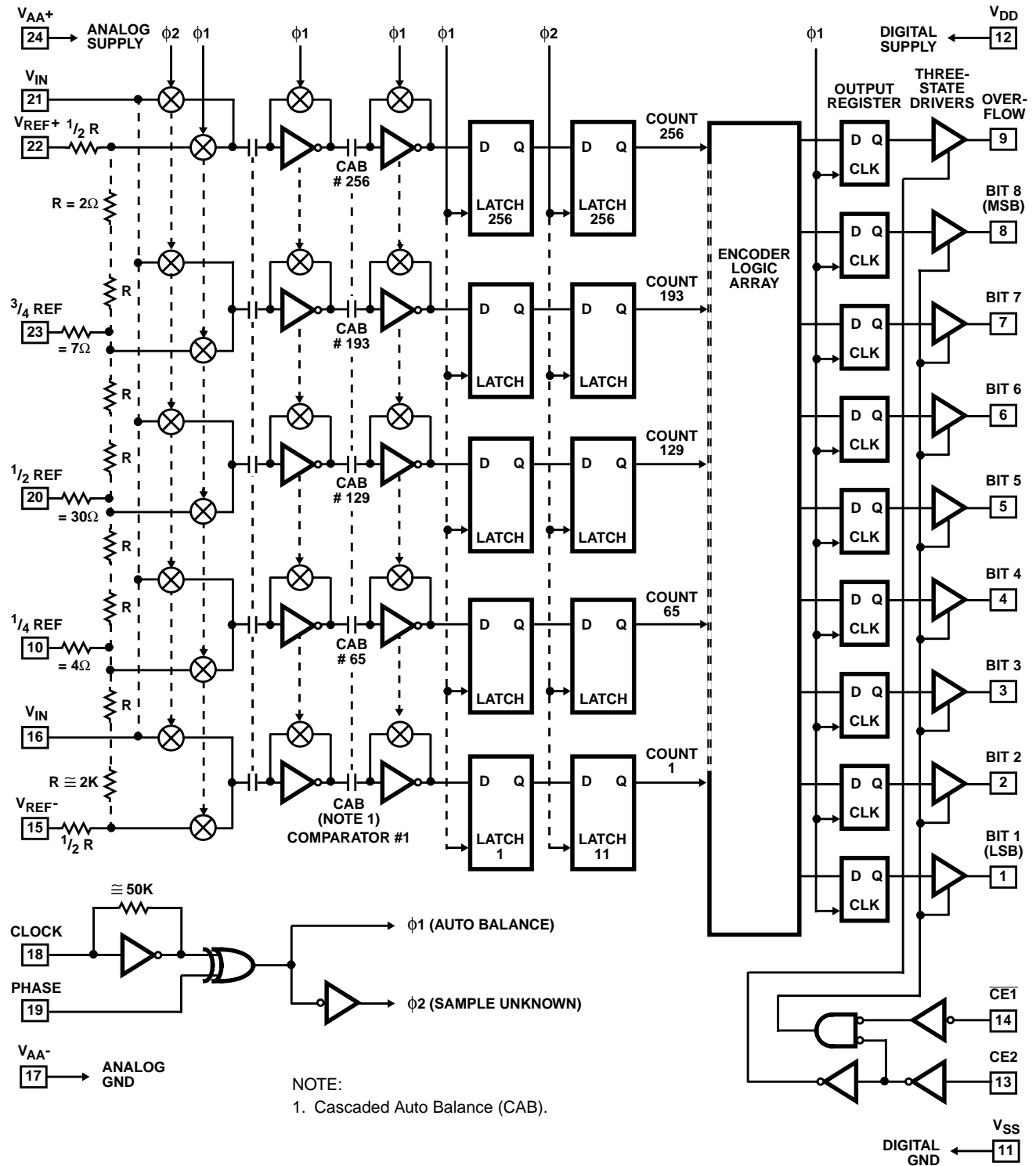

CA3318

Absolute Maximum Ratings

DC Supply Voltage Range (V_{DD} or V_{AA+})	-0.5V to +8V (Referenced to V_{SS} or V_{AA-} Terminal, Whichever is More Negative)
Input Voltage Range	
CE2 and CE1	V_{AA-} -0.5V to V_{DD} + 0.5V
Clock, Phase, V_{REF-} , $1/2$ Ref.	V_{AA-} -0.5V to V_{AA+} + 0.5V
Clock, Phase, V_{REF+} , $1/4$ Ref.	V_{SS} -0.5V to V_{DD} + 0.5V
V_{IN} , $3/4$ REF, V_{REF+}	V_{AA-} -0.5V to V_{AA-} + 7.5V
Output Voltage Range, Bits 1-8, Overflow (Outputs Off)	V_{SS} - 0.5V to V_{DD} + 0.5V
DC Input Current	± 20 mA
Clock, Phase, CE1, CE2, V_{IN} , Bits 1-8, Overflow	

Thermal Information

Thermal Resistance (Typical, Note 1)	θ_{JA} ($^{\circ}$ C/W)	θ_{JC} ($^{\circ}$ C/W)
SBDIP Package	60	22
PDIP Package	60	N/A
SOIC Package	75	N/A
Maximum Junction Temperature		
Ceramic Package		175 $^{\circ}$ C
Plastic Packages		150 $^{\circ}$ C
Maximum Storage Temperature Range		-65 $^{\circ}$ C to 150 $^{\circ}$ C
Maximum Lead Temperature (Soldering 10s)		265 $^{\circ}$ C (SOIC - Lead Tips Only)

Operating Conditions

Operating Voltage Range (V_{DD} or V_{AA+})	4V (Min) to 7.5V (Max)
Recommended V_{AA+} Operating Range	$V_{DD} \pm 1$ V
Recommended V_{AA-} Operating Range	$V_{SS} \pm 1$ V
Operating Temperature Range (T_A)	-40 $^{\circ}$ C to 85 $^{\circ}$ C

CAUTION: Stresses above those listed in "Absolute Maximum Ratings" may cause permanent damage to the device. This is a stress only rating and operation of the device at these or any other conditions above those indicated in the operational sections of this specification is not implied.

NOTE:

- θ_{JA} is measured with the component mounted on an evaluation PC board in free air.

Electrical Specifications

At 25 $^{\circ}$ C, $V_{AA+} = V_{DD} = 5$ V, $V_{REF+} = 6.4$ V, $V_{REF-} = V_{AA-} = V_{SS}$, CLK = 15MHz,
All Reference Points Adjusted, Unless Otherwise Specified

PARAMETER	TEST CONDITIONS	MIN	TYP	MAX	UNITS
SYSTEM PERFORMANCE					
Resolution		8	-	-	Bits
Integral Linearity Error		-	-	± 1.5	LSB
Differential Linearity Error		-	-	+1, -0.8	LSB
Offset Error, Unadjusted	$V_{IN} = V_{REF-} + 1/2$ LSB	-0.5	4.5	6.4	LSB
Gain Error Unadjusted	$V_{IN} = V_{REF+} - 1/2$ LSB	-1.5	0	1.5	LSB
DYNAMIC CHARACTERISTICS					
Maximum Input Bandwidth	(Note 1) CA3318	2.5	5.0	-	MHz
Maximum Conversion Speed	CLK = Square Wave	15	17	-	MSPS
Signal to Noise Ratio (SNR)	$f_S = 15$ MHz, $f_{IN} = 100$ kHz	-	47	-	dB
$\frac{RMS_{Signal}}{RMS_{Noise}}$	$f_S = 15$ MHz, $f_{IN} = 4$ MHz	-	43	-	dB
Signal to Noise Ratio (SINAD)	$f_S = 15$ MHz, $f_{IN} = 100$ kHz	-	45	-	dB
$\frac{RMS_{Signal}}{RMS_{Noise+Distortion}}$	$f_S = 15$ MHz, $f_{IN} = 4$ MHz	-	35	-	dB
Total Harmonic Distortion, THD	$f_S = 15$ MHz, $f_{IN} = 100$ kHz	-	-46	-	dBc
	$f_S = 15$ MHz, $f_{IN} = 4$ MHz	-	-36	-	dBc
Effective Number of Bits (ENOB)	$f_S = 15$ MHz, $f_{IN} = 100$ kHz	-	7.2	-	Bits
	$f_S = 15$ MHz, $f_{IN} = 4$ MHz	-	5.5	-	Bits
Differential Gain Error	Unadjusted	-	2	-	%
Differential Phase Error	Unadjusted	-	1	-	%
ANALOG INPUTS					
Full Scale Range, V_{IN} and (V_{REF+}) - (V_{REF-})	Notes 2, 4	4	-	7	V
Input Capacitance, V_{IN}		-	30	-	pF
Input Current, V_{IN} , (See Text)	$V_{IN} = 5$ V, $V_{REF+} = 5$ V	-	-	3.5	mA
REFERENCE INPUTS					
Ladder Impedance		270	500	800	Ω

CA3318

Electrical Specifications At 25°C, $V_{AA+} = V_{DD} = 5V$, $V_{REF+} = 6.4V$, $V_{REF-} = V_{AA-} = V_{SS}$, CLK = 15MHz,
All Reference Points Adjusted, Unless Otherwise Specified **(Continued)**

PARAMETER	TEST CONDITIONS	MIN	TYP	MAX	UNITS
DIGITAL INPUTS					
Low Level Input Voltage, V_{OL} CE1, CE2	Note 4	-	-	$0.2V_{DD}$	V
Phase, CLK	Note 4	-	-	$0.2V_{AA}$	V
High Level Input Voltage, V_{IN} CE1, CE2	Note 4	$0.7V_{DD}$	-	-	V
Phase, CLK	Note 4	$0.7V_{AA}$	-	-	V
Input Leakage Current, I_I (Except CLK Input)	Note 3	-	± 0.2	± 5	μA
Input Capacitance, C_I		-	3	-	pF
DIGITAL OUTPUTS					
Output Low (Sink) Current	$V_O = 0.4V$	4	10	-	mA
Output High (Source) Current	$V_O = 4.5V$	-4	-6	-	mA
Three-State Output Off-State Leakage Current, I_{OZ}		-	± 0.2	± 5	μA
Output Capacitance, C_O		-	4	-	pF
TIMING CHARACTERISTICS					
Auto Balance Time ($\phi 1$)		33	-	∞	ns
Sample Time ($\phi 2$)	Note 4	25	-	500	ns
Aperture Delay		-	15	-	ns
Aperture Jitter		-	100	-	ps
Data Valid Time, t_D	Note 4	-	50	65	ns
Data Hold Time, t_H	Note 4	25	40	-	ns
Output Enable Time, t_{EN}		-	18	-	ns
Output Disable Time, t_{DIS}		-	18	-	ns
POWER SUPPLY CHARACTERISTICS					
Device Current ($I_{DD} + I_A$) (Excludes I_{REF})	Continuous Conversion (Note 4)	-	30	60	mA
	Auto Balance ($\phi 1$)	-	30	60	mA

NOTES:

1. A full scale sine wave input of greater than $f_{CLOCK}/2$ or the specified input bandwidth (whichever is less) may cause an erroneous code. The -3dB bandwidth for frequency response purposes is greater than 30MHz.
2. V_{IN} (Full Scale) or V_{REF+} should not exceed $V_{AA+} + 1.5V$ for accuracy.
3. The clock input is a CMOS inverter with a 50k Ω feedback resistor and may be AC coupled with 1V_{p-p} minimum source.
4. Parameter not tested, but guaranteed by design or characterization.

Timing Waveforms

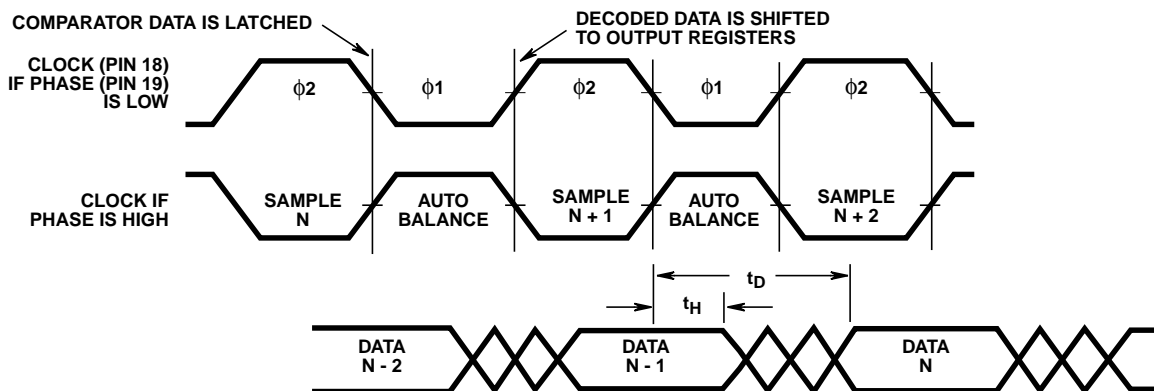

FIGURE 1. INPUT TO OUTPUT TIMING DIAGRAM

Timing Waveforms (Continued)

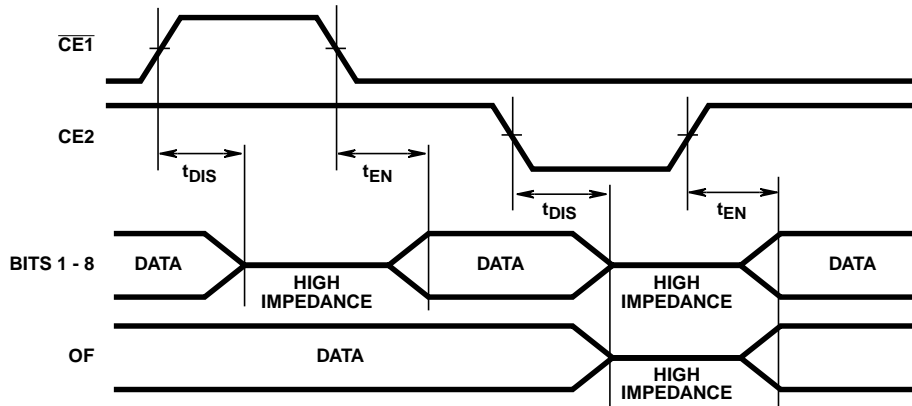

FIGURE 2. OUTPUT ENABLE TIMING DIAGRAM

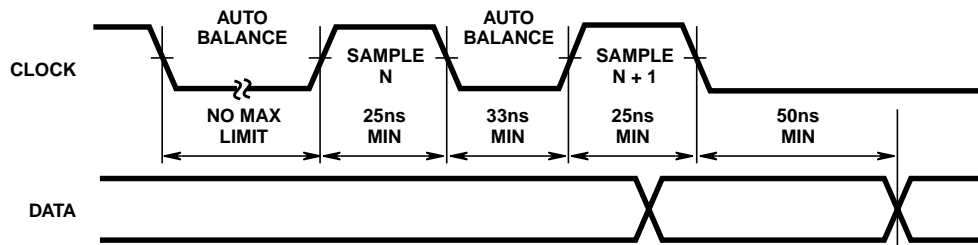

FIGURE 3A. STANDBY IN INDEFINITE AUTO BALANCE (SHOWN WITH PHASE = LOW)

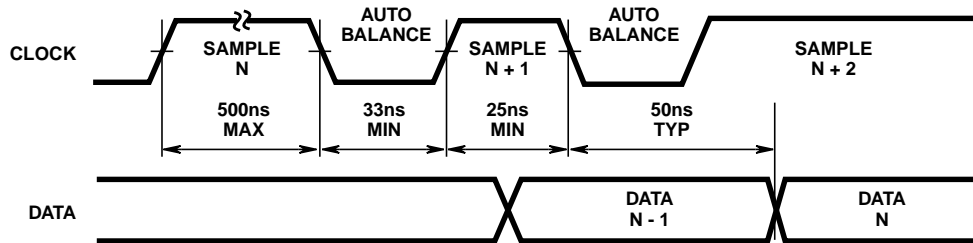

FIGURE 3B. STANDBY IN SAMPLE (SHOWN WITH PHASE = LOW)

FIGURE 3. PULSE MODE OPERATION

Typical Performance Curves

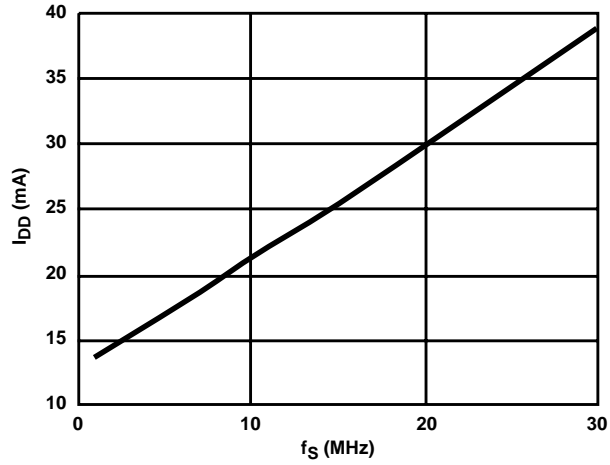

FIGURE 4. DEVICE CURRENT vs SAMPLE FREQUENCY

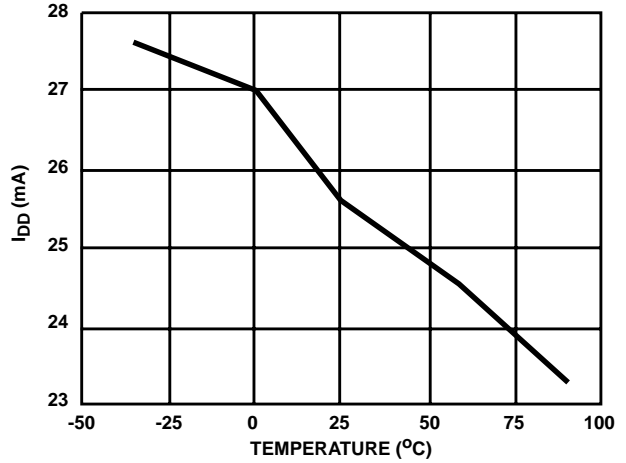

FIGURE 5. DEVICE CURRENT vs TEMPERATURE

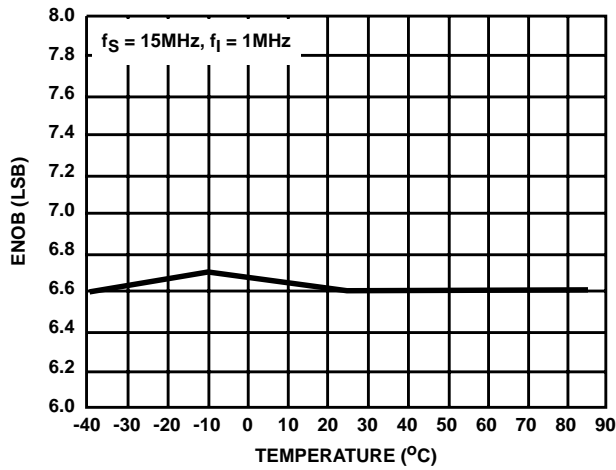

FIGURE 6. ENOB vs TEMPERATURE

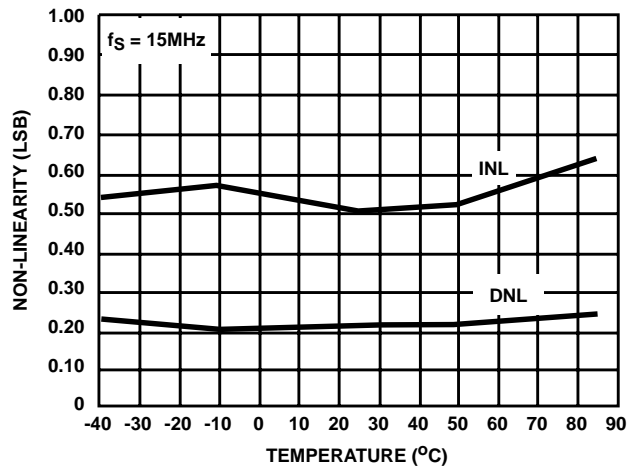

FIGURE 7. NON-LINEARITY vs TEMPERATURE

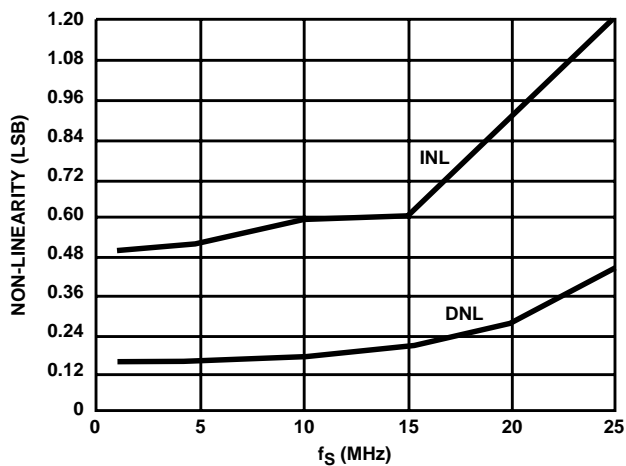

FIGURE 8. NON-LINEARITY vs SAMPLE FREQUENCY

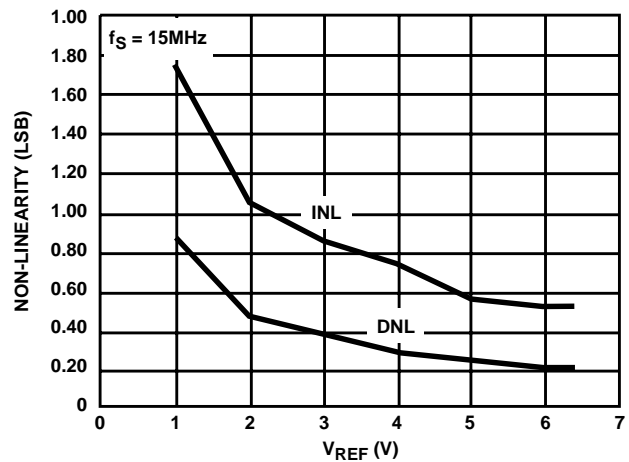

FIGURE 9. NON-LINEARITY vs REFERENCE VOLTAGE

Typical Performance Curves (Continued)

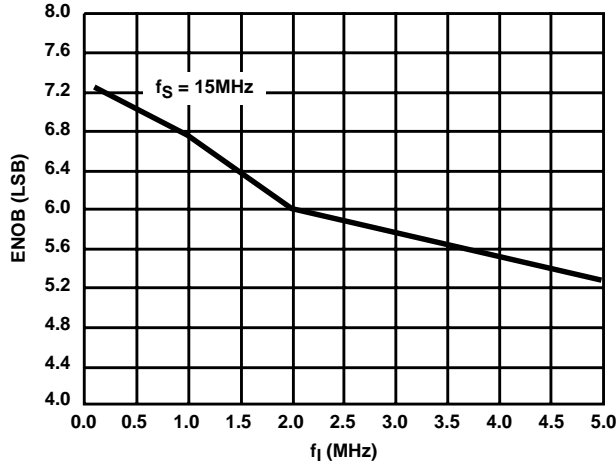

FIGURE 10. ENOB vs INPUT FREQUENCY

Pin Descriptions

PIN	NAME	DESCRIPTION	
1	B1	Bit 1 (LSB)	Output Data Bits (High = True)
2	B2	Bit 2	
3	B3	Bit 3	
4	B4	Bit 4	
5	B5	Bit 5	
6	B6	Bit 6	
7	B7	Bit 7	
8	B8	Bit 8 (MSB)	
9	OF	Overflow	
10	$1/4 R$	Reference Ladder $1/4$ Point	
11	V_{SS}	Digital Ground	
12	V_{DD}	Digital Power Supply, +5V	
13	CE2	Three-State Output Enable Input, Active Low, See Truth Table.	
14	$\overline{CE1}$	Three-State Output Enable Input Active High. See Truth Table.	
15	V_{REF-}	Reference Voltage Negative Input	
16	V_{IN}	Analog Signal Input	
17	V_{AA-}	Analog Ground	
18	CLK	Clock Input	
19	PHASE	Sample clock phase control input. When PHASE is low, "Sample Unknown" occurs when the clock is low and "Auto Balance" occurs when the clock is high (see text).	
20	$1/2 R$	Reference Ladder Midpoint	
21	V_{IN}	Analog Signal Input	
22	V_{REF+}	Reference Voltage Positive Input	
23	$3/4 R$	Reference Ladder $3/4$ Point	
24	V_{AA+}	Analog Power Supply, +5V	

CHIP ENABLE TRUTH TABLE

$\overline{CE1}$	CE2	B1 - B8	OF
0	1	Valid	Valid
1	1	Three-State	Valid
X	0	Three-State	Three-State

X = Don't Care

Theory of Operation

A sequential parallel technique is used by the CA3318 converter to obtain its high speed operation. The sequence consists of the "Auto-Balance" phase, $\phi1$, and the "Sample Unknown" phase, $\phi2$. (Refer to the circuit diagram.) Each conversion takes one clock cycle (see Note). With the phase control (pin 19) high, the "Auto-Balance" ($\phi1$) occurs during the high period of the clock cycle, and the "Sample Unknown" ($\phi2$) occurs during the low period of the clock cycle.

NOTE: The device requires only a single phase clock. The terminology of $\phi1$ and $\phi2$ refers to the high and low periods of the same clock.

During the "Auto-Balance" phase, a transmission switch is used to connect each of the first set of 256 commutating capacitors to their associated ladder reference tap. Those tap voltages will be as follows:

$$V_{TAP}(N) = [(N/256) V_{REF-}] - (1/512) V_{REF+}$$

$$= [(2N - 1)/512] V_{REF+}$$

Where:

$V_{TAP}(n)$ = reference ladder tap voltage at point n,

V_{REF} = voltage across V_{REF-} to V_{REF+} ,

N = tap number (1 through 256).

The other side of these capacitors are connected to single-stage amplifiers whose outputs are shorted to their inputs by switches. This balances the amplifiers at their intrinsic trip points, which is approximately $(V_{AA+} - V_{AA-})/2$. The first set of capacitors now charges to their associated tap voltages.

At the same time a second set of commutating capacitors and amplifiers is also auto-balanced. The balancing of the second-stage amplifier at its intrinsic trip point removes any tracking differences between the first and second amplifier stages. The cascaded auto-balance (CAB) technique, used here, increases comparator sensitivity and temperature tracking.

In the “Sample Unknown” phase, all ladder tap switches and comparator shorting switches are opened. At the same time V_{IN} is switched to the first set of commutating capacitors. Since the other end of the capacitors are now looking into an effectively open circuit, any input voltage that differs from the previous tap voltage will appear as a voltage shift at the comparator amplifiers. All comparators that had tap voltages greater than V_{IN} will go to a “high” state at their outputs. All comparators that had tap voltages lower than V_{IN} will go to a “low” state.

The status of all these comparator amplifiers is AC coupled through the second-stage comparator and stored at the end of this phase (ϕ_2) by a latching amplifier stage. The latch feeds a second latching stage, triggered at the end of ϕ_1 . This delay allows comparators extra settling time. The status of the comparators is decoded by a 256 to 9-bit decoder array, and the results are clocked into a storage register at the end of the next ϕ_2 .

A 3-stage buffer is used at the output of the 9 storage registers which are controlled by two chip-enable signals. CE1 will independently disable B1 through B6 when it is in a high state. CE2 will independently disable B1 through B8 and the OF buffers when it is in the low state.

To facilitate usage of this device, a phase control input is provided which can effectively complement the clock as it enters the chip.

Continuous-Clock Operation

One complete conversion cycle can be traced through the CA3318 via the following steps. (Refer to timing diagram.) With the phase control in a “low” state, the rising edge of the clock input will start a “sample” phase. During this entire “high” state of the clock, the comparators will track the input voltage and the first-stage latches will track the comparator outputs. At the falling edge of the clock, all 256 comparator outputs are captured by the 256 latches. This ends the “sample” phase and starts the “auto-balance” phase for the comparators. During this “low” state of the clock, the output of the latches settles and is captured by a second row of latches when the clock returns high. The second-stage latch output propagates through the decode array, and a 9-bit code appears at the D inputs of the output registers. On the next falling edge of the clock, this 9-bit code is shifted into the output registers and appears with time delay t_D as valid data at the output of the three-state drivers. This also marks the end of the next “sample” phase, thereby repeating the conversion process for this next cycle.

Pulse-Mode Operation

The CA3318 needs two of the same polarity clock edges to complete a conversion cycle: If, for instance, a negative going clock edge ends sample “N”, then data “N” will appear after the next negative going edge. Because of this requirement, and because there is a maximum sample time of 500ns (due to capacitor droop), most pulse or intermittent sample applications will require double clock pulsing.

If an indefinite standby state is desired, standby should be in auto-balance, and the operation would be as in Figure 3A.

If the standby state is known to last less than 500ns and lowest average power is desired, then operation could be as in Figure 3B.

Increased Accuracy

In most cases the accuracy of the CA3318 should be sufficient without any adjustments. In applications where accuracy is of utmost importance, five adjustments can be made to obtain better accuracy, i.e., offset trim; gain trim; and $1/4$, $1/2$ and $3/4$ point trim.

Offset Trim

In general, offset correction can be done in the preamp circuitry by introducing a DC shift to V_{IN} or by the offset trim of the op amp. When this is not possible the V_{REF-} input can be adjusted to produce an offset trim. The theoretical input voltage to produce the first transition is $1/2$ LSB. The equation is as follows:

$$V_{IN} (0 \text{ to } 1 \text{ transition}) = 1/2 \text{ LSB} = 1/2 (V_{REF}/256) \\ = V_{REF}/512.$$

If V_{IN} for the first transition is less than the theoretical, then a single-turn 50Ω pot connected between V_{REF-} and ground will accomplish the adjustment. Set V_{IN} to $1/2$ LSB and trim the pot until the 0-to-1 transition occurs.

If V_{IN} for the first transition is greater than the theoretical, then the 50Ω pot should be connected between V_{REF-} and a negative voltage of about 2 LSBs. The trim procedure is as stated previously.

Gain Trim

In general, the gain trim can also be done in the preamp circuitry by introducing a gain adjustment for the op amp. When this is not possible, then a gain adjustment circuit should be made to adjust the reference voltage. To perform this trim, V_{IN} should be set to the 255 to overflow transition. That voltage is $1/3$ LSB less than V_{REF+} and is calculated as follows:

$$V_{IN} (255 \text{ to } 256 \text{ transition}) = V_{REF} - V_{REF}/512 \\ = V_{REF}(511/512).$$

To perform the gain trim, first do the offset trim and then apply the required V_{IN} for the 255 to overflow transition. Now adjust V_{REF+} until that transition occurs on the outputs.

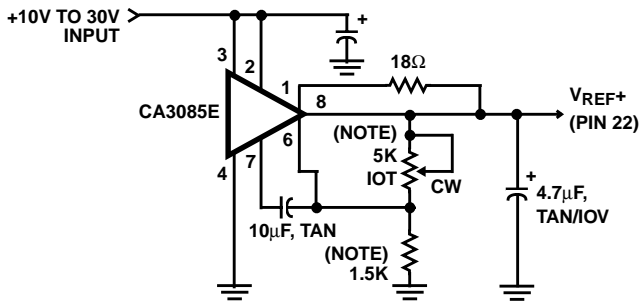

NOTE: Bypass V_{REF+} to analog GND near A/D with 0.1μF ceramic cap. Parts noted should have low temperature drift.

FIGURE 11. TYPICAL VOLTAGE REFERENCE SOURCE FOR DRIVING V_{REF+} INPUT

1/4 Point Trims

The 1/4, 1/2 and 3/4 points on the reference ladder are brought out for linearity adjusting or if the user wishes to create a nonlinear transfer function. The 1/4 points can be driven by the reference drivers shown (Figure 12) or by 2-K pots connected between V_{REF+} and V_{REF-} . The 1/2 (mid-) point should be set first by applying an input of $257/512 \times (V_{REF})$ and adjusting for an output changing from 128 to 129. Similarly the 1/4 and 3/4 points can be set with inputs of $129/512$ and $385/512 \times (V_{REF})$ and adjusting for counts of 192 to 193 and 64 to 65. (Note that the points are actually 1/4, 1/2 and 3/4 of full scale +1 LSB.)

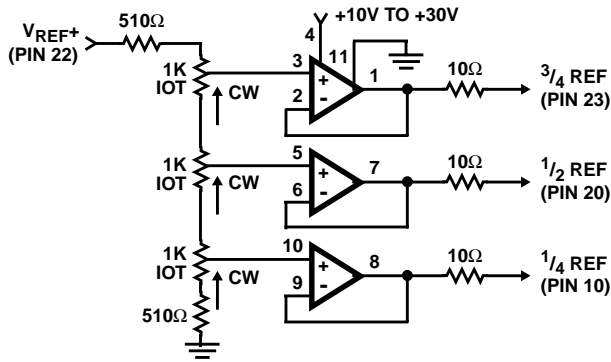

NOTES:

1. All Op Amps = 3/4 CA324E.
2. Bypass all reference points to analog ground near A/D with 0.1μF ceramic caps.
3. Adjust V_{REF+} first, then 1/3, 3/4 and 1/4 points.

FIGURE 12. TYPICAL 1/4 POINT DRIVERS FOR ADJUSTING LINEARITY (USE FOR MAXIMUM LINEARITY)

9-Bit Resolution

To obtain 9-bit resolution, two CA3318s can be wired together. Necessary ingredients include an open-ended ladder network, an overflow indicator, three-state outputs, and chip-enable controls - all of which are available on the CA3318.

The first step for connecting a 9-bit circuit is to totem-pole the ladder networks, as illustrated in Figure 13. Since the absolute resistance value of each ladder may vary, external trim of the mid-reference voltage may be required.

The overflow output of the lower device now becomes the ninth bit. When it goes high, all counts must come from the upper device. When it goes low, all counts must come from the lower device. This is done simply by connecting the lower overflow signal to the CE1 control of the lower A/D converter and the CE2 control of the upper A/D converter. The three-state outputs of the two devices (bits 1 through 8) are now connected in parallel to complete the circuitry. The complete circuit for a 9-bit A/D converter is shown in Figure 13.

Grounding/Bypassing

The analog and digital supply grounds of a system should be kept separate and only connected at the A/D. This keeps digital ground noise out of the analog data to be converted. Reference drivers, input amps, reference taps, and the V_{AA} supply should be bypassed at the A/D to the analog side of the ground. See Figure 15 for a block diagram of this concept. All capacitors shown should be low impedance 0.1μF ceramics and should be mounted as close to the A/D as possible. If V_{AA+} is derived from V_{DD} , a small (10Ω resistor or inductor and additional filtering (4.7μF tantalum) may be used to keep digital noise out of the analog system.

Input Loading

The CA3318 outputs a current pulse to the V_{IN} terminal at the start of every sample period. This is due to capacitor charging and switch feedthrough and varies with input voltage and sampling rate. The signal source must be capable of recovering from the pulse before the end of the sample period to guarantee a valid signal for the A/D to convert. Suitable high speed amplifiers include the HA-5033, HA-2542; and CA3450. Figure 16 is an example of an amplifier which recovers fast enough for sampling at 15MHz.

Output Loading

The CMOS digital output stage, although capable of driving large loads, will reflect these loads into the local ground. It is recommended that a local QMOS buffer such as CD74HC541 E be used to isolate capacitive loads.

Definitions

Dynamic Performance Definitions

Fast Fourier Transform (FFT) techniques are used to evaluate the dynamic performance of the converter. A low distortion sine wave is applied to the input, it is sampled, and the output is stored in RAM. The data is then transformed into the frequency domain with a 4096 point FFT and analyzed to evaluate the dynamic performance of the A/D. The sine wave input to the part is -0.5dB down from fullscale for all these tests.

Signal-to-Noise (SNR)

SNR is the measured RMS signal to RMS noise at a specified input and sampling frequency. The noise is the RMS sum of all of the spectral components except the fundamental and the first five harmonics.

CA3318

Signal-to-Noise + Distortion Ratio (SINAD)

SINAD is the measured RMS signal to RMS sum of all other spectral components below the Nyquist frequency excluding DC.

Effective Number of Bits (ENOB)

The effective number of bits (ENOB) is derived from the SINAD data. ENOB is calculated from:

$$\text{ENOB} = (\text{SINAD} - 1.76 + V_{\text{CORR}})/6.02,$$

where: $V_{\text{CORR}} = 0.5\text{dB}$.

Total Harmonic Distortion (THD)

THD is the ratio of the RMS sum of the first 5 harmonic components to the RMS value of the measured input signal.

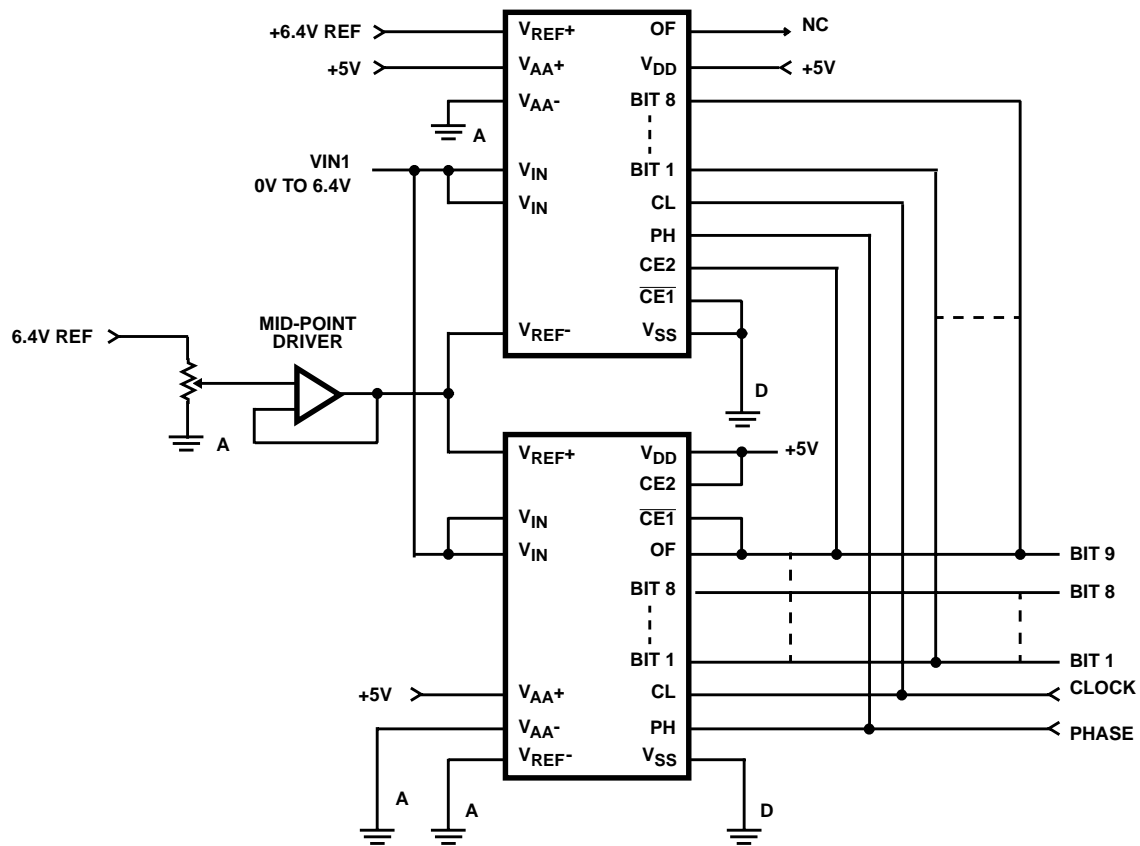

FIGURE 13. USING TWO CA3318s FOR 9-BIT RESOLUTION

CA3318

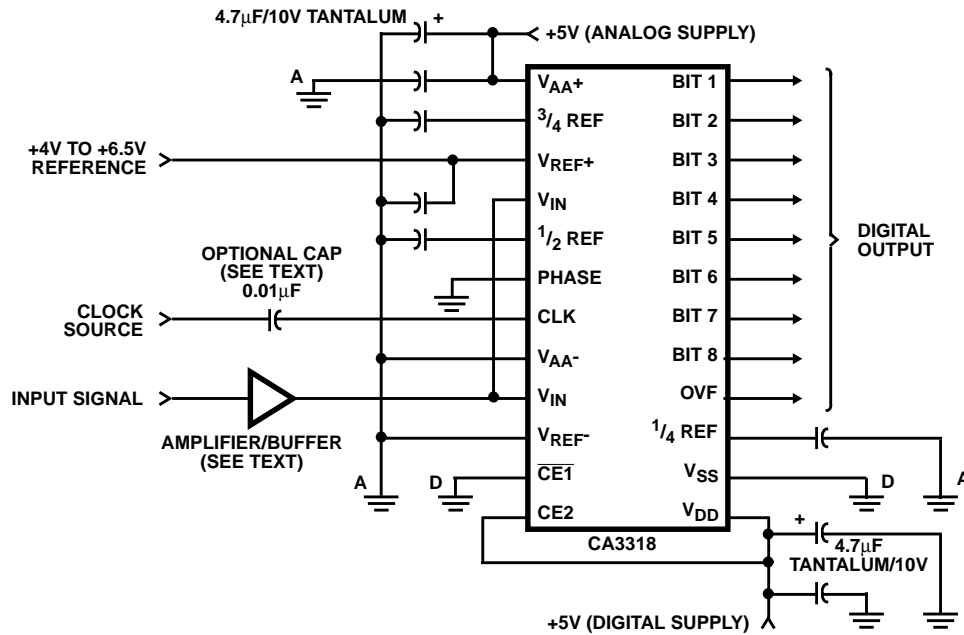

FIGURE 14. TYPICAL CIRCUIT CONFIGURATION FOR THE CA3318 WITH NO LINEARITY ADJUST

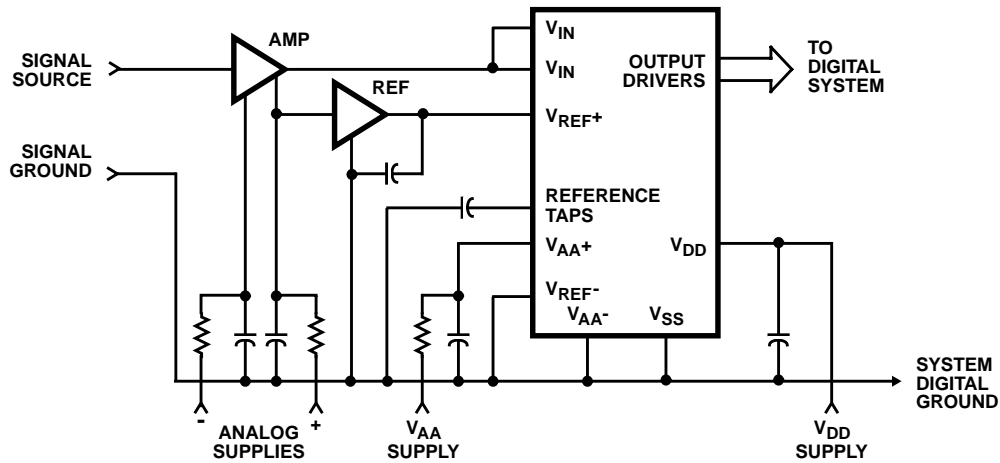
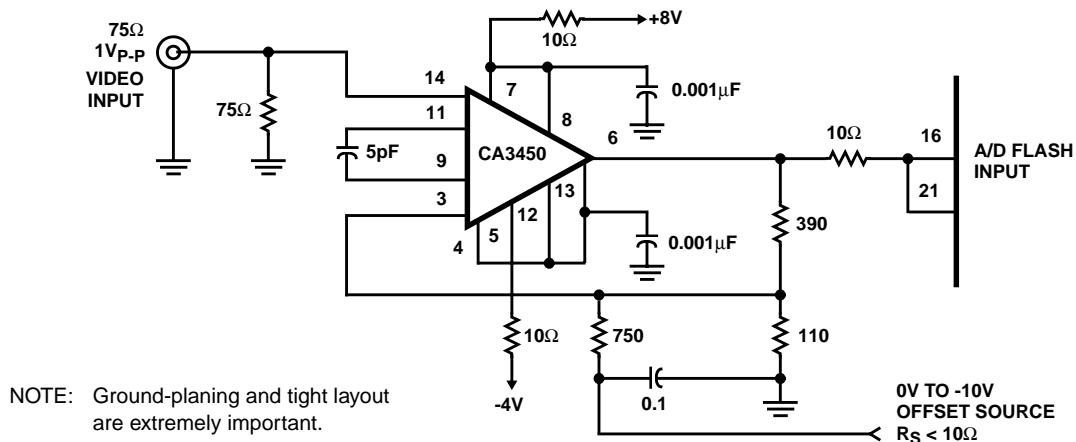

FIGURE 15. TYPICAL SYSTEM GROUNDING/BYPASSING



NOTE: Ground-planing and tight layout are extremely important.

FIGURE 16. TYPICAL HIGH BANDWIDTH AMPLIFIER FOR DRIVING THE CA3318

TABLE 1. OUTPUT CODE TABLE

CODE DESCRIPTION	(NOTE 1) INPUT VOLTAGE		BINARY OUTPUT CODE									DECIMAL COUNT
	V _{REF} 6.40V (V)	V _{REF} 5.12V (V)	OF	MSB B8	B7	B6	B5	B4	B3	B2	LSB B1	
Zero	0.00	0.00	0	0	0	0	0	0	0	0	0	0
1 LSB	0.025	0.02	0	0	0	0	0	0	0	0	1	1
2 LSB	0.05	0.04	0	0	0	0	0	0	0	1	0	2
•	•	•										•
•	•	•										•
•	•	•										•
1/4 Full Scale	1.60	1.28	0	0	1	0	0	0	0	0	0	64
•	•	•										•
•	•	•										•
•	•	•										•
1/2 Full Scale - 1 LSB	3.175	2.54	0	0	1	1	1	1	1	1	1	127
1/2 Full Scale	3.20	2.56	0	1	0	0	0	0	0	0	0	128
1/2 Full Scale + 1 LSB	3.225	2.58	0	1	0	0	0	0	0	0	1	129
•	•	•										•
•	•	•										•
•	•	•										•
3/4 Full Scale	4.80	3.84	0	1	1	0	0	0	0	0	0	192
•	•	•										•
•	•	•										•
•	•	•										•
Full Scale - 1 LSB	6.35	5.08	0	1	1	1	1	1	1	1	0	254
Full Scale	6.375	5.10	0	1	1	1	1	1	1	1	1	255
Over Flow	6.40	5.12	1	1	1	1	1	1	1	1	1	511

NOTE: 1. The voltages listed above are the ideal centers of each output code shown as a function of its associated reference voltage.

Reducing Power

Most power is consumed while in the auto-balance state. When operating at lower than 15MHz clock speed, power can be reduced by stretching the sample (ϕ_2) time. The constraints are a minimum balance time (ϕ_1) of 33ns, and a maximum sample time of 500ns. Longer sample times cause droop in the auto-balance capacitors. Power can also be reduced in the reference string by switching the reference on only during auto-balance.

Clock Input

The Clock and Phase inputs feed buffers referenced to V_{AA+} and V_{AA-} . Phase should be tied to one of these two potentials, while the clock (if DC coupled) should be driven at least from 0.2 to 0.7 x ($V_{AA+} - V_{AA-}$). The clock may also be AC coupled with at least a 1V_{P-P} swing. This allows TTL drive levels or 5V QMOS levels when V_{AA+} is greater than 5V.

All Intersil semiconductor products are manufactured, assembled and tested under **ISO9000** quality systems certification.

Intersil products are sold by description only. Intersil Corporation reserves the right to make changes in circuit design and/or specifications at any time without notice. Accordingly, the reader is cautioned to verify that data sheets are current before placing orders. Information furnished by Intersil is believed to be accurate and reliable. However, no responsibility is assumed by Intersil or its subsidiaries for its use; nor for any infringements of patents or other rights of third parties which may result from its use. No license is granted by implication or otherwise under any patent or patent rights of Intersil or its subsidiaries.

For information regarding Intersil Corporation and its products, see web site <http://www.intersil.com>

This datasheet has been downloaded from:

www.DatasheetCatalog.com

Datasheets for electronic components.



LittleDiode supplies new, hard to find or obsolete electronic components and semiconductors all over the world.

With over two million different components listed you are sure to find the part you need.

Feel free to visit us today at our online store:

LittleDiode.com

Looking forward to providing you with the best possible service.