



CAT28F102

1 Megabit CMOS Flash Memory

**Licensed Intel
second source**

FEATURES

- Fast Read Access Time: 45/55/70/90 ns
- Low Power CMOS Dissipation:
 - Active: 30 mA max (CMOS/TTL levels)
 - Standby: 1 mA max (TTL levels)
 - Standby: 100 μ A max (CMOS levels)
- High Speed Programming:
 - 10 μ s per byte
 - 1 Sec Typ Chip Program
- 0.5 Seconds Typical Chip-Erase
- 12.0V \pm 5% Programming and Erase Voltage
- Commercial, Industrial and Automotive Temperature Ranges
- 64K x 16 Word Organization
- Stop Timer for Program/Erase
- On-Chip Address and Data Latches
- JEDEC Standard Pinouts:
 - 40-pin DIP
 - 44-pin PLCC
 - 40-pin TSOP
- 100,000 Program/Erase Cycles
- 10 Year Data Retention
- Electronic Signature

DESCRIPTION

The CAT28F102 is a high speed 64K x 16-bit electrically erasable and reprogrammable Flash memory ideally suited for applications requiring in-system or after-sale code updates. Electrical erasure of the full memory contents is achieved typically within 0.5 second.

It is pin and Read timing compatible with standard EPROM and E²PROM devices. Programming and Erase are performed through an operation and verify algorithm. The instructions are input via the I/O bus, using a

two write cycle scheme. Address and Data are latched to free the I/O bus and address bus during the write operation.

The CAT28F102 is manufactured using Catalyst's advanced CMOS floating gate technology. It is designed to endure 100,000 program/erase cycles and has a data retention of 10 years. The device is available in JEDEC approved 40-pin DIP, 44-pin PLCC, or 40-pin TSOP packages.

BLOCK DIAGRAM

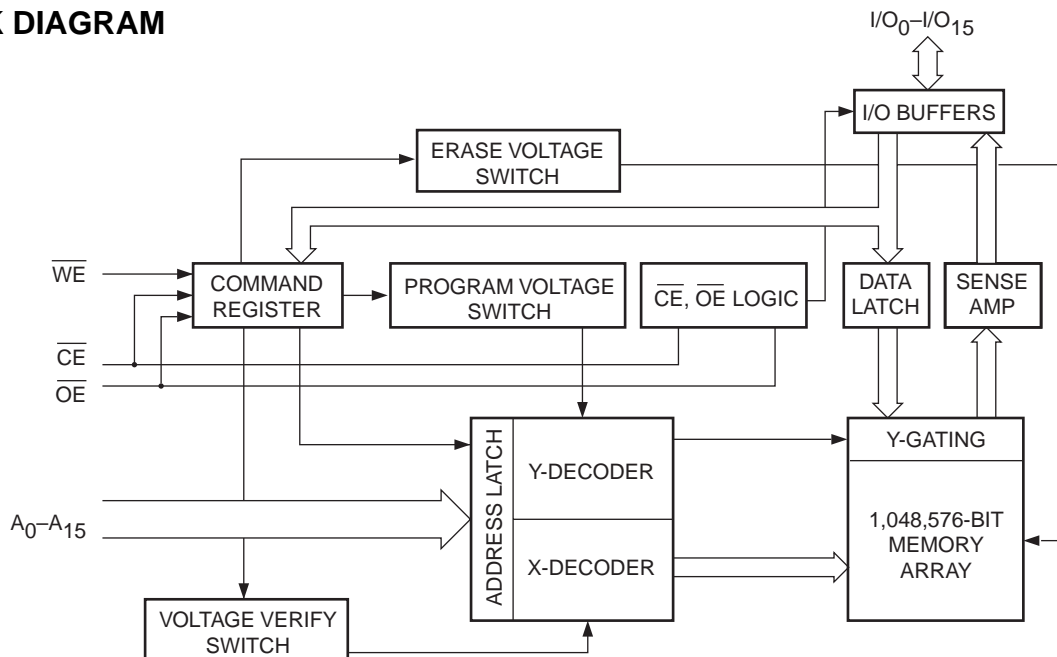

28F101-1

PIN CONFIGURATION

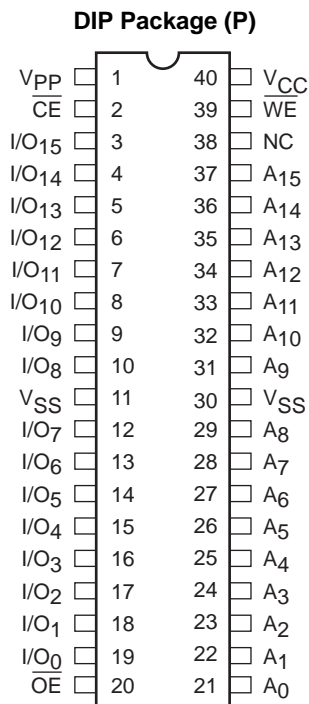
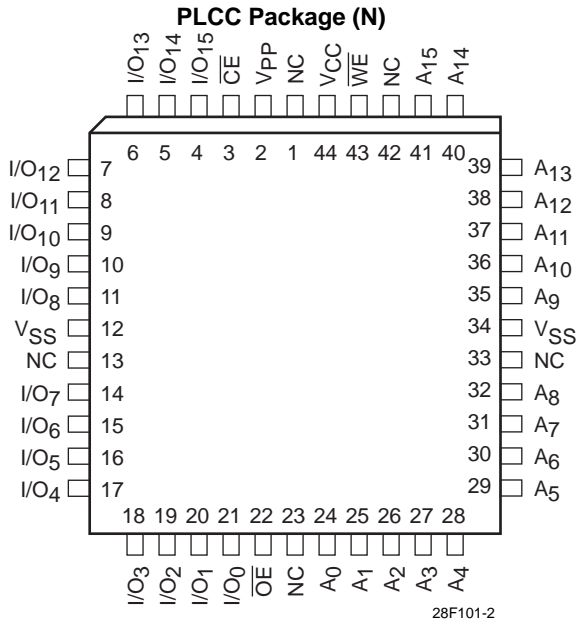

PIN FUNCTIONS

Pin Name	Type	Function
A ₀ –A ₁₅	Input	Address Inputs for memory addressing
I/O ₀ –I/O ₁₅	I/O	Data Input/Output
CE	Input	Chip Enable
OE	Input	Output Enable
WE	Input	Write Enable
V _{CC}		Voltage Supply
V _{SS}		Ground
V _{PP}		Program/Erase Voltage Supply
NC		No Connect

TSOP Package (T14)

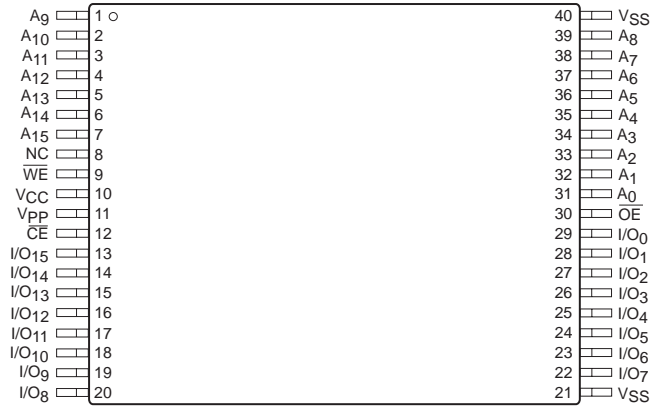

Reverse TSOP Package (T14R)



ABSOLUTE MAXIMUM RATINGS*

Temperature Under Bias	-55°C to +95°C
Storage Temperature	-65°C to +150°C
Voltage on Any Pin with Respect to Ground ⁽¹⁾	-0.6V to +V _{CC} + 2.0V
Voltage on Pin A ₉ with Respect to Ground ⁽¹⁾	-2.0V to +13.5V
V _{PP} with Respect to Ground during Program/Erase ⁽¹⁾	-0.6V to +14.0V
V _{CC} with Respect to Ground ⁽¹⁾	-2.0V to +7.0V
Package Power Dissipation Capability (T _A = 25°C)	1.0 W
Lead Soldering Temperature (10 secs)	300°C
Output Short Circuit Current ⁽²⁾	100 mA

***COMMENT**

Stresses above those listed under “Absolute Maximum Ratings” may cause permanent damage to the device. These are stress ratings only, and functional operation of the device at these or any other conditions outside of those listed in the operational sections of this specification is not implied. Exposure to any absolute maximum rating for extended periods may affect device performance and reliability.

RELIABILITY CHARACTERISTICS

Symbol	Parameter	Min.	Max.	Units	Test Method
N _{END} ⁽³⁾	Endurance	100K		Cycles/Byte	MIL-STD-883, Test Method 1033
T _{DR} ⁽³⁾	Data Retention	10		Years	MIL-STD-883, Test Method 1008
V _{ZAP} ⁽³⁾	ESD Susceptibility	2000		Volts	MIL-STD-883, Test Method 3015
I _{LTH} ⁽³⁾⁽⁴⁾	Latch-Up	100		mA	JEDEC Standard 17

CAPACITANCE T_A = 25°C, f = 1.0 MHz

Symbol	Test	Limits		Units	Conditions
		Min	Max.		
C _{IN} ⁽³⁾	Input Pin Capacitance		6	pF	V _{IN} = 0V
C _{OUT} ⁽³⁾	Output Pin Capacitance		10	pF	V _{OUT} = 0V
C _{VPP} ⁽³⁾	V _{PP} Supply Capacitance		25	pF	V _{PP} = 0V

Note:

- (1) The minimum DC input voltage is -0.5V. During transitions, inputs may undershoot to -2.0V for periods of less than 20 ns. Maximum DC voltage on output pins is V_{CC} + 0.5V, which may overshoot to V_{CC} + 2.0V for periods of less than 20ns.
- (2) Output shorted for no more than one second. No more than one output shorted at a time.
- (3) This parameter is tested initially and after a design or process change that affects the parameter.
- (4) Latch-up protection is provided for stresses up to 100 mA on address and data pins from -1V to V_{CC} + 1V.

D.C. OPERATING CHARACTERISTICS

V_{CC} = +5V ±10%, unless otherwise specified

Symbol	Parameter	Limits			Test Conditions
		Min.	Max.	Unit	
I _{LI}	Input Leakage Current		±1	µA	V _{IN} = V _{CC} or V _{SS} V _{CC} = 5.5V, \overline{OE} = V _{IH}
I _{LO}	Output Leakage Current		±1	µA	V _{OUT} = V _{CC} or V _{SS} , V _{CC} = 5.5V, \overline{OE} = V _{IH}
I _{SB1}	V _{CC} Standby Current CMOS		100	µA	\overline{CE} = V _{CC} ±0.5V, V _{CC} = 5.5V
I _{SB2}	V _{CC} Standby Current TTL		1	mA	\overline{CE} = V _{IH} , V _{CC} = 5.5V
I _{CC1}	V _{CC} Active Read Current		50	mA	V _{CC} = 5.5V, \overline{CE} = V _{IL} , I _{OUT} = 0mA, f = 6 MHz
I _{CC2} ⁽¹⁾	V _{CC} Programming Current		30	mA	V _{CC} = 5.5V, Programming in Progress
I _{CC3} ⁽¹⁾	V _{CC} Erase Current		30	mA	V _{CC} = 5.5V, Erasure in Progress
I _{CC4} ⁽¹⁾	V _{CC} Prog./Erase Verify Current		30	mA	V _{CC} = 5.5V, Program or Erase Verify in Progress
I _{PPS}	V _{PP} Standby Current		±10	µA	V _{PP} = V _{PPL}
I _{PP1}	V _{PP} Read Current		100	µA	V _{PP} = V _{PPH}
I _{PP2} ⁽¹⁾	V _{PP} Programming Current		50	mA	V _{PP} = V _{PPH} , Programming in Progress
I _{PP3} ⁽¹⁾	V _{PP} Erase Current		30	mA	V _{PP} = V _{PPH} , Erasure in Progress
I _{PP4} ⁽¹⁾	V _{PP} Prog./Erase Verify Current		5	mA	V _{PP} = V _{PPH} , Program or Erase Verify in Progress
V _{IL}	Input Low Level TTL	-0.5	0.8	V	
V _{ILC}	Input Low Level CMOS	-0.5	0.8	V	
V _{OL}	Output Low Level		0.45	V	I _{OL} = 5.8mA, V _{CC} = 4.5V
V _{IH}	Input High Level TTL	2	V _{CC} +0.5	V	
V _{IHC}	Input High Level CMOS	V _{CC} *0.7	V _{CC} +0.5	V	
V _{OH1}	Output High Level TTL	2.4		V	I _{OH} = -2.5mA, V _{CC} = 4.5V
V _{OH2}	Output High Level CMOS	V _{CC} -0.4		V	I _{OH} = -400µA, V _{CC} = 4.5V
V _{ID}	A ₉ Signature Voltage	11.4	13.0	V	A ₉ = V _{ID}
I _{ID} ⁽¹⁾	A ₉ Signature Current		200	µA	A ₉ = V _{ID}
V _{LO}	V _{CC} Erase/Prog. Lockout Voltage	2.5		V	
Supply Characteristics					
V _{CC}	V _{CC} Supply Voltage	4.5	5.5	V	28F102-70, 90
V _{CC}	V _{CC} Supply Voltage	4.75	5.25	V	28F102-55, -45
V _{PPL}	V _{PP} During Read Operations	0	6.5	V	
V _{PPH}	V _{PP} During Read/Erase/Program	11.4	12.6	V	

A.C. CHARACTERISTICS, Read Operation

V_{CC} = +5V ±10%, unless otherwise specified

JEDEC Symbol	Standard Symbol	Parameter	28F102-45 ⁽⁷⁾ V _{CC} =5V±5%		28F102-55 ⁽⁷⁾ V _{CC} =5V±5%		28F102-70 ⁽⁷⁾		28F102- 90 ⁽⁸⁾		Unit
			Min.	Max.	Min.	Max.	Min.	Max.	Min.	Max.	
t _{AVAV}	t _{RC}	Read Cycle Time	45		55		70		90		ns
t _{ELQV}	t _{CE}	\overline{CE} Access Time		45		55		70		90	ns
t _{AVQV}	t _{ACC}	Address Access Time		45		55		70		90	ns
t _{GLQV}	t _{OE}	\overline{OE} Access Time		20		25		28		35	ns
t _{AXQX}	t _{OH}	Output Hold from Address $\overline{OE}/\overline{CE}$ Chan	0		0		0		0		ns
t _{GLQX}	t _{OLZ} ⁽¹⁾⁽⁶⁾	\overline{OE} to Output in Low-Z	0		0		0		0		ns
t _{ELQX}	t _{LZ} ⁽¹⁾⁽⁶⁾	\overline{CE} to Output in Low-Z	0		0		0		0		ns
t _{GHQZ}	t _{DF} ⁽¹⁾⁽²⁾	\overline{OE} High to Output High-Z		15		15		18		20	ns
t _{EHQZ} ⁽¹⁾⁽²⁾	-	\overline{CE} High to Output High-Z		15		15		25		30	ns
t _{WHGL}		Write Recovery Time Before Read	6		6		6		6		μs

Figure 1. A.C. Testing Input/Output Waveform⁽³⁾⁽⁴⁾⁽⁵⁾

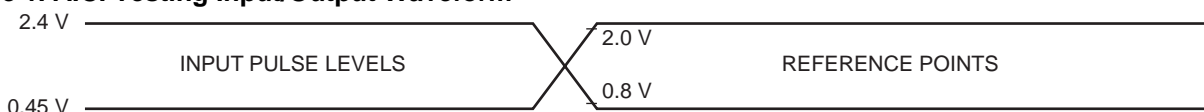

5108 FHD F03

Figure 2. A.C. Testing Load Circuit (example)

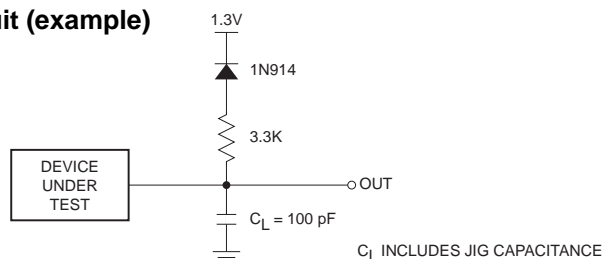

5108 FHD F04

Figure 3. High Speed A.C. Testing Input/Output Waveform⁽³⁾⁽⁴⁾⁽⁵⁾

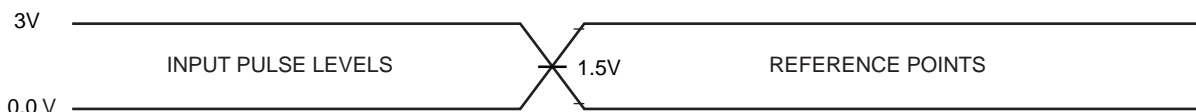
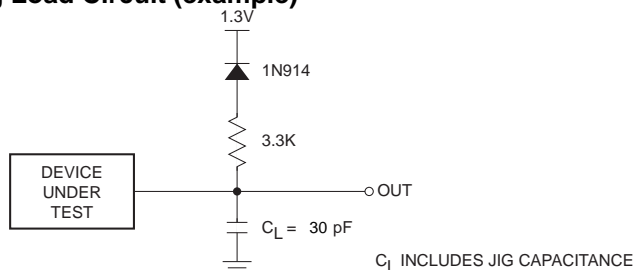

Figure 4. High Speed A.C. Testing Load Circuit (example)



Note:

- (1) This parameter is tested initially and after a design or process change that affects the parameter.
- (2) Output floating (High-Z) is defined as the state where the external data line is no longer driven by the output buffer.
- (3) Input Rise and Fall Times (10% to 90%) < 10 ns.
- (4) Input Pulse Levels = 0.45V and 2.4V. For high speed input pulse levels 0.0V and 3.0V.
- (5) Input and Output Timing Reference = 0.8V and 2.0V. For high speed input and output timing reference=1.5V.
- (6) Low-Z is defined as the state where the external data may be driven by the output buffer but may not be valid.
- (7) For Load and Reference Points see Figures 3 and 4
- (8) For Load and Reference Points see Figures 1 and 2

A.C. CHARACTERISTICS, Program/Erase Operation

V_{CC} = +5V ±10%, unless otherwise specified.

JEDEC Symbol	Standard Symbol	Parameter	28F102-45 V _{CC} = +5V ±5%		28F102-55 V _{CC} = +5V ±5%		28F102-70		28F102-90		Unit
			Min.	Max.	Min.	Max.	Min.	Max.	Min.	Max.	
t _{AVAV}	t _{WC}	Write Cycle Time	45		55		70		90		ns
t _{AVWL}	t _{AS}	Address Setup Time	0		0		0		0		ns
t _{WLAX}	t _{AH}	Address Hold Time	30		30		35		40		ns
t _{DVWH}	t _{DS}	Data Setup Time	30		30		35		40		ns
t _{WHDX}	t _{DH}	Data Hold Time	10		10		10		10		ns
t _{ELWL}	t _{CS}	\overline{CE} Setup Time	0		0		0		0		ns
t _{WHEH}	t _{CH}	\overline{CE} Hold Time	0		0		0		0		ns
t _{WLWH}	t _{WP}	\overline{WE} Pulse Width	30		30		35		40		ns
t _{WHWL}	t _{WPH}	\overline{WE} High Pulse Width	20		20		20		20		ns
t _{WHWH1} ⁽²⁾	-	Program Pulse Width	10		10		10		10		μs
t _{WHWH2} ⁽²⁾	-	Erase Pulse Width	9.5		9.5		9.5		9.5		ms
t _{WHGL}	-	Write Recovery Time Before Read	6		6		6		6		μs
t _{GHWL}	-	Read Recovery Time Before Write	0		0		0		0		μs
t _{VPEL}	-	V _{PP} Setup Time to \overline{CE}	100		100		100		100		ns

Erase and Programming Performance (1)

Parameter	28F102-45			28F102-55			28F102-70			28F102-90			Unit
	Min.	Typ.	Max.	Min.	Typ.	Max.	Min.	Typ.	Max.	Min.	Typ.	Max.	
Chip Erase Time ⁽³⁾⁽⁵⁾		0.5	10		0.5	10		0.5	10		0.5	10	sec
Chip Program Time ⁽³⁾⁽⁴⁾		1	6.5		1	6.5		1	6.5		1	6.5	sec

Note:

- (1) Please refer to Supply characteristics for the value of V_{PPH} and V_{PPL}. The V_{PP} supply can be either hardwired or switched. If V_{PP} is switched, V_{PPL} can be ground, less than V_{CC} + 2.0V or a no connect with a resistor tied to ground.
- (2) Program and Erase operations are controlled by internal stop timers.
- (3) 'Typicals' are not guaranteed, but based on characterization data. Data taken at 25°C, 12.0V V_{PP}.
- (4) Minimum byte programming time (excluding system overhead) is 16 μs (10 μs program + 6 μs write recovery), while maximum is 400 μs/byte (16 μs x 25 loops). Max chip programming time is specified lower than the worst case allowed by the programming algorithm since most bytes program significantly faster than the worst case byte.
- (5) Excludes 00H Programming prior to Erasure.

FUNCTION TABLE⁽¹⁾

Mode	Pins					Notes
	\overline{CE}	\overline{OE}	\overline{WE}	V_{PP}	I/O	
Read	V_{IL}	V_{IL}	V_{IH}	V_{PPL}	D_{OUT}	
Output Disable	V_{IL}	V_{IH}	V_{IH}	X	High-Z	
Standby	V_{IH}	X	X	V_{PPL}	High-Z	
Signature (MFG)	V_{IL}	V_{IL}	V_{IH}	V_{PPL}	0031H	$A_0 = V_{IL}, A_9 = 12V$
Signature (Device)	V_{IL}	V_{IL}	V_{IH}	X	0051H	$A_0 = V_{IH}, A_9 = 12V$
Program/Erase	V_{IL}	V_{IH}	V_{IL}	V_{PPH}	D_{IN}	See Command Table
Write Cycle	V_{IL}	V_{IH}	V_{IL}	V_{PPH}	D_{IN}	During Write Cycle
Read Cycle	V_{IL}	V_{IL}	V_{IH}	V_{PPH}	D_{OUT}	During Write Cycle
Output Disable	V_{IL}	V_{IH}	V_{IH}	V_{PPH}	High-Z	During Write Cycle
Standby	V_{IH}	X	X	V_{PPH}	High-Z	During Write Cycle

WRITE COMMAND TABLE

Commands are written into the command register in one or two write cycles. The command register can be altered only when V_{pp} is high and the instruction byte is latched on the rising edge of \overline{WE} . Write cycles also internally latch addresses and data required for programming and erase operations.

Mode	Pins						
	First Bus Cycle			Second Bus Cycle			
	Operation	Address	D_{IN}	Operation	Address	D_{IN}	D_{OUT}
Set Read	Write	X	XX00H	Read	A_{IN}		D_{OUT}
Read Sig. (MFG)	Write	X	XX90H	Read	0000		0031H
Read Sig. (Device)	Write	X	XX90H	Read	0001		0051H
Erase	Write	X	XX20H	Write	X	XX20H	
Erase Verify	Write	A_{IN}	XXA0H	Read	X		D_{OUT}
Program	Write	X	XX40H	Write	A_{IN}	D_{IN}	
Program Verify	Write	X	XXC0H	Read	X		D_{OUT}
Reset	Write	X	XXFFH	Write	X	XXFFH	

Note:

(1) Logic Levels: X = Logic 'Do not care' (V_{IH} , V_{IL} , V_{PPL} , V_{PPH})

READ OPERATIONS

Read Mode

A Read operation is performed with both \overline{CE} and \overline{OE} low and with \overline{WE} high. V_{PP} can be either high or low, however, if V_{PP} is high, the Set READ command has to be sent before reading data (see Write Operations). The data retrieved from the I/O pins reflects the contents of the memory location corresponding to the state of the 16 address pins. The respective timing waveforms for the read operation are shown in Figure 5. Refer to the AC Read characteristics for specific timing parameters.

Signature Mode

The signature mode allows the user to identify the IC manufacturer and the type of device while the device resides in the target system. This mode can be activated in either of two ways; through the conventional method of applying a high voltage (12V) to address pin A_9 or by sending an instruction to the command register (see Write Operations).

The conventional mode is entered as a regular READ mode by driving the \overline{CE} and \overline{OE} pins low (with \overline{WE} high), and applying the required high voltage on address pin A_9 while all other address lines are held at V_{IL} .

A Read cycle from address 0000H retrieves the binary code for the IC manufacturer on outputs I/O₀ to I/O₁₅:

CATALYST Code = 0000 0000 0011 0001 (0031H)

A Read cycle from address 0001H retrieves the binary code for the device on outputs I/O₀ to I/O₁₅.

28F102 Code = 0000 0000 0101 0001 (0051H)

Standby Mode

With \overline{CE} at a logic-high level, the CAT28F102 is placed in a standby mode where most of the device circuitry is disabled, thereby substantially reducing power consumption. The outputs are placed in a high-impedance state.

Figure 5. A.C. Timing for Read Operation

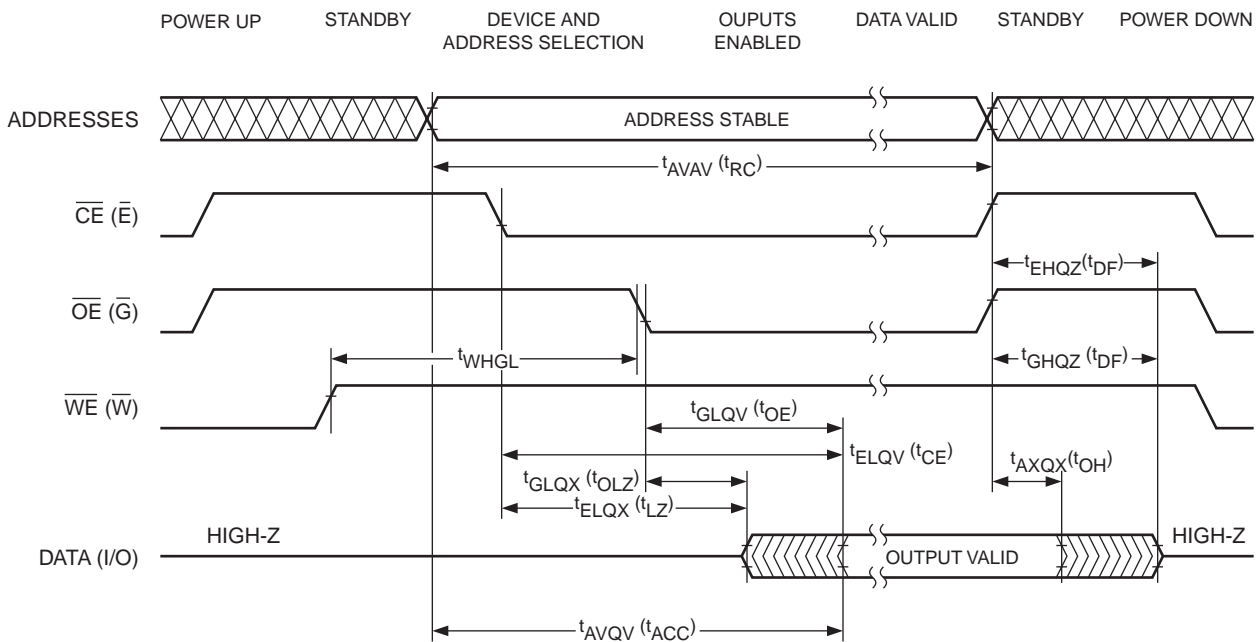

28F102 Fig. 6

WRITE OPERATIONS

The following operations are initiated by observing the sequence specified in the Write Command Table.

Read Mode

The device can be put into a standard READ mode by initiating a write cycle with XX00H on the data bus. The subsequent read cycles will be performed similar to a standard EPROM or E²PROM Read.

Signature Mode

An alternative method for reading device signature (see Read Operations Signature Mode), is initiated by writing the code XX90H into the command register while keeping V_{PP} high. A read cycle from address 0000H with \overline{CE} and \overline{OE} low (and \overline{WE} high) will output the device signature.

CATALYST Code = 0000 0000 0011 0001 (0031H)

A Read cycle from address 0001H retrieves the binary code for the device on outputs I/O₀ to I/O₇.

28F102 Code = 0000 0000 0101 0001 (0051H)

Erase Mode

During the first Write cycle, the command XX20H is written into the command register. In order to commence the erase operation, the identical command of XX20H has to be written again into the register. This two-step process ensures against accidental erasure of the memory contents. The final erase cycle will be stopped at the rising edge of \overline{WE} , at which time the Erase Verify command (XXA0H) is sent to the command register. During this cycle, the address to be verified is sent to the address bus and latched when \overline{WE} goes low. An integrated stop timer allows for automatic timing control over this operation, eliminating the need for a maximum erase timing specification. Refer to AC Characteristics (Program/Erase) for specific timing parameters.

Figure 6. A.C. Timing for Erase Operation

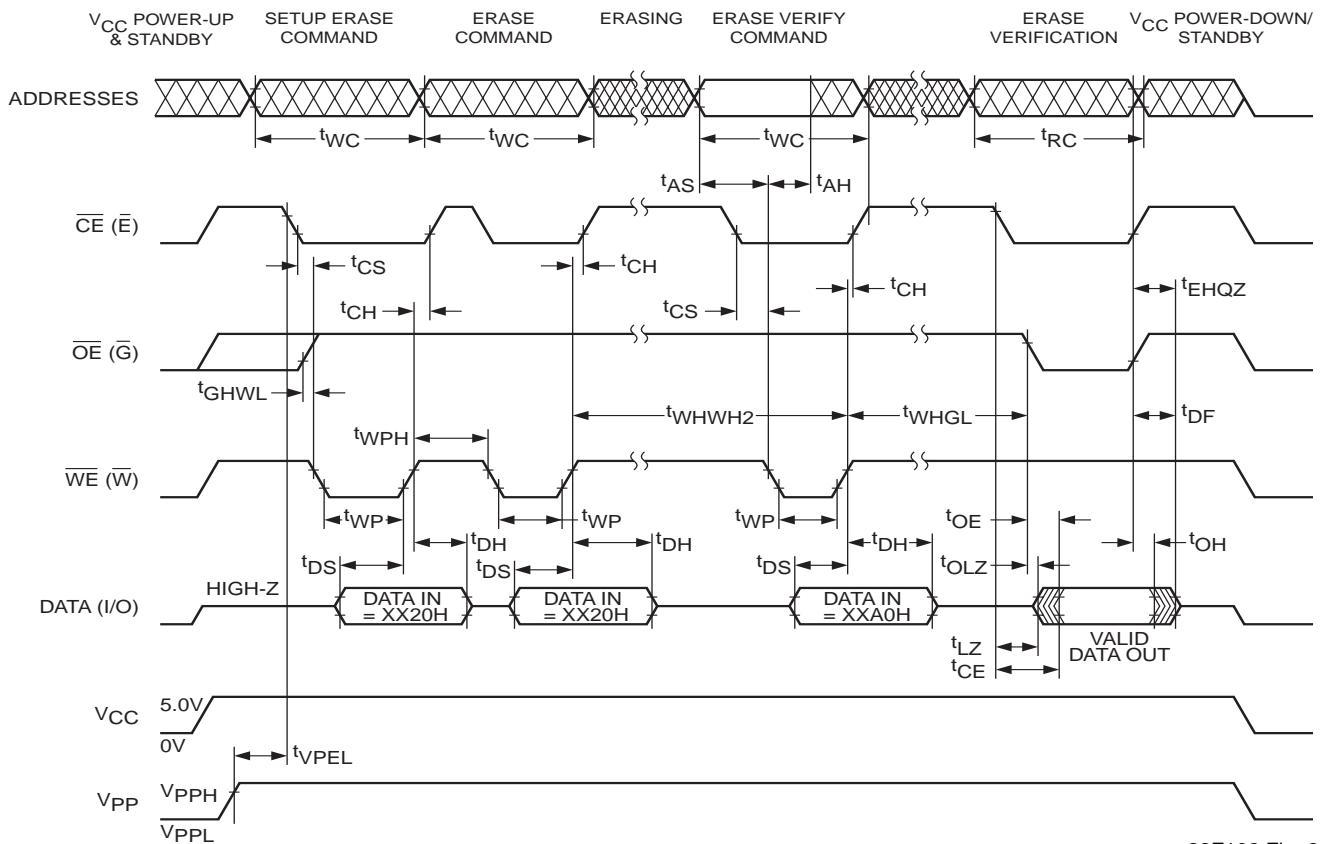

28F102 Fig. 6

Figure 7. Chip Erase Algorithm(1)

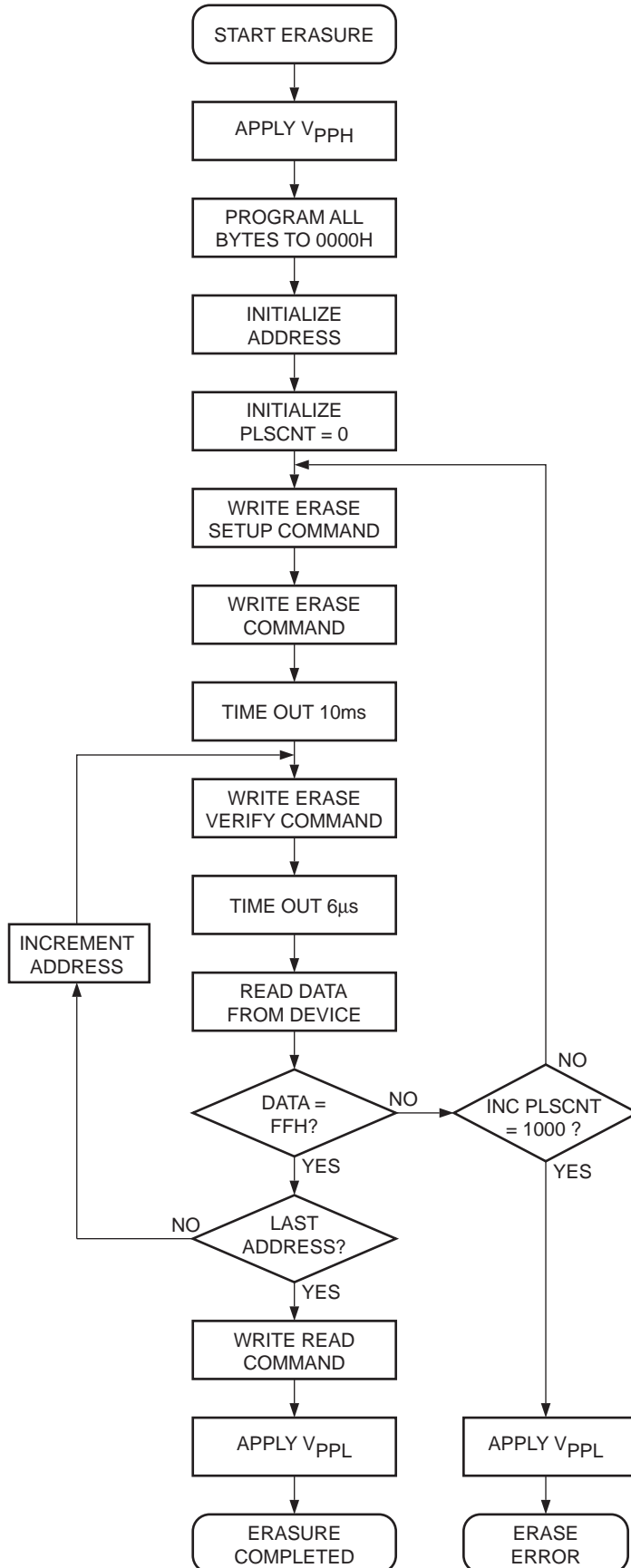

BUS OPERATION	COMMAND	COMMENTS
STANDBY		V _{pp} RAMPS TO V _{ppH} (OR V _{pp} HARDWIRED) ALL BYTES SHALL BE PROGRAMMED TO 00 BEFORE AN ERASE OPERATION INITIALIZE ADDRESS PLSCNT = PULSE COUNT
WRITE	ERASE	DATA = XX20H
WRITE	ERASE	DATA = XX20H
		WAIT
WRITE	ERASE VERIFY	ADDRESS = BYTE TO VERIFY DATA = XXA0H STOPS ERASE OPERATION
		WAIT
READ		READ BYTE TO VERIFY ERASURE
STANDBY		COMPARE OUTPUT TO FF INCREMENT PULSE COUNT
WRITE	READ	DATA = 0000H RESETS THE REGISTER FOR READ OPERATION
STANDBY		V _{pp} RAMPS TO V _{ppL} (OR V _{pp} HARDWIRED)

Note:

(1) The algorithm MUST BE FOLLOWED to ensure proper and reliable operation of the device.

28F101-07

Erase-Verify Mode

The Erase-verify operation is performed on every byte after each erase pulse to verify that the bits have been erased.

Programming Mode

The programming operation is initiated using the programming algorithm of Figure 9. During the first write cycle, the command XX40H is written into the command register. During the second write cycle, the address of the memory location to be programmed is latched on the falling edge of \overline{WE} , while the data is latched on the rising edge of \overline{WE} . The program operation terminates with the next rising edge of \overline{WE} . An integrated stop timer allows for automatic timing control over this operation, eliminating the need for a maximum program timing specification. Refer to AC Characteristics (Program/Erase) for specific timing parameters.

Program-Verify Mode

A Program-verify cycle is performed to ensure that all bits have been correctly programmed following each byte programming operation. The specific address is already latched from the write cycle just completed, and stays latched until the verify is completed. The Program-verify operation is initiated by writing XXC0H into the command register. An internal reference generates the necessary high voltages so that the user does not need to modify V_{CC} . Refer to AC Characteristics (Program/Erase) for specific timing parameters.

Figure 8. A.C. Timing for Programming Operation

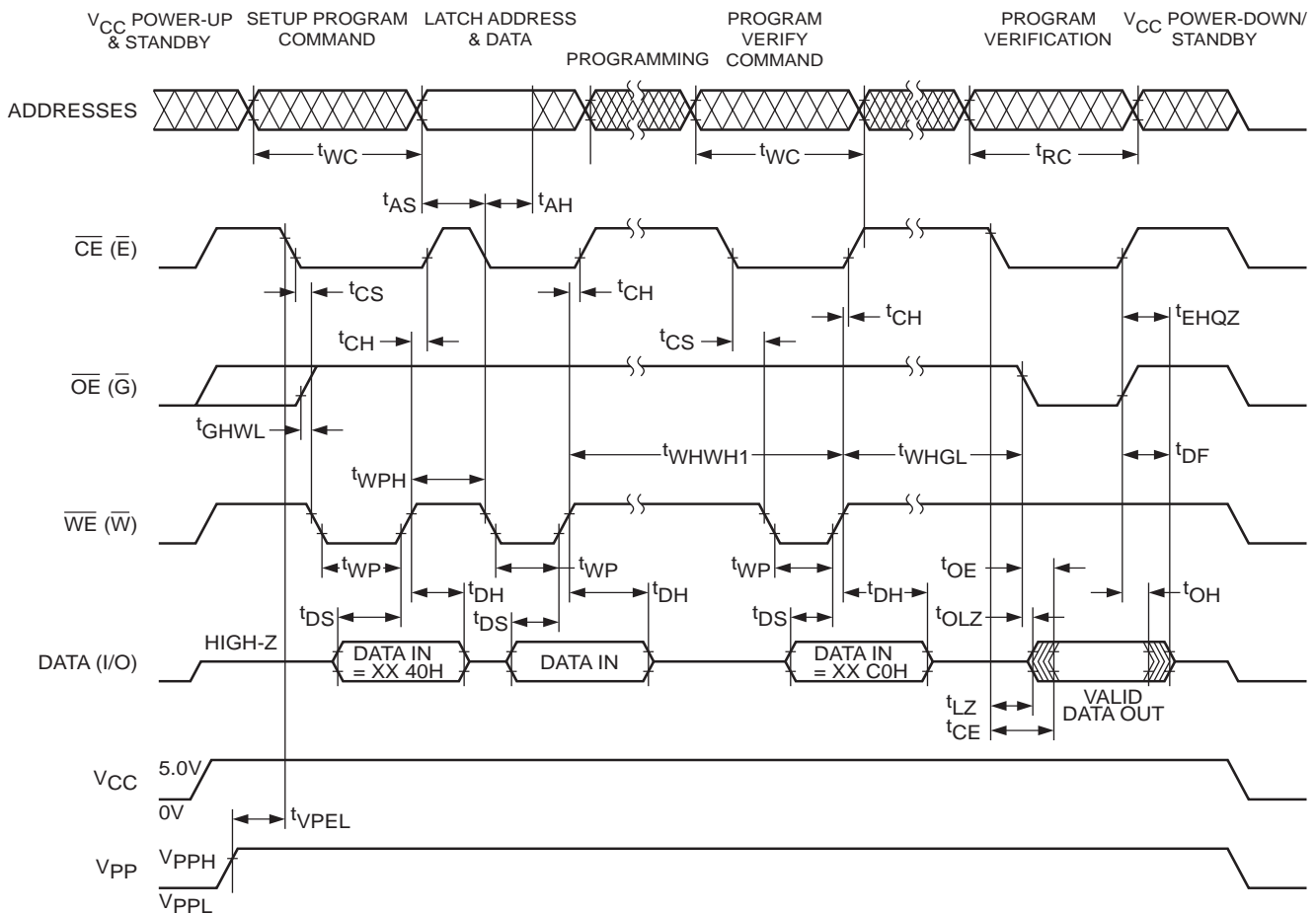

28F102 F07

Figure 9. Programming Algorithm⁽¹⁾

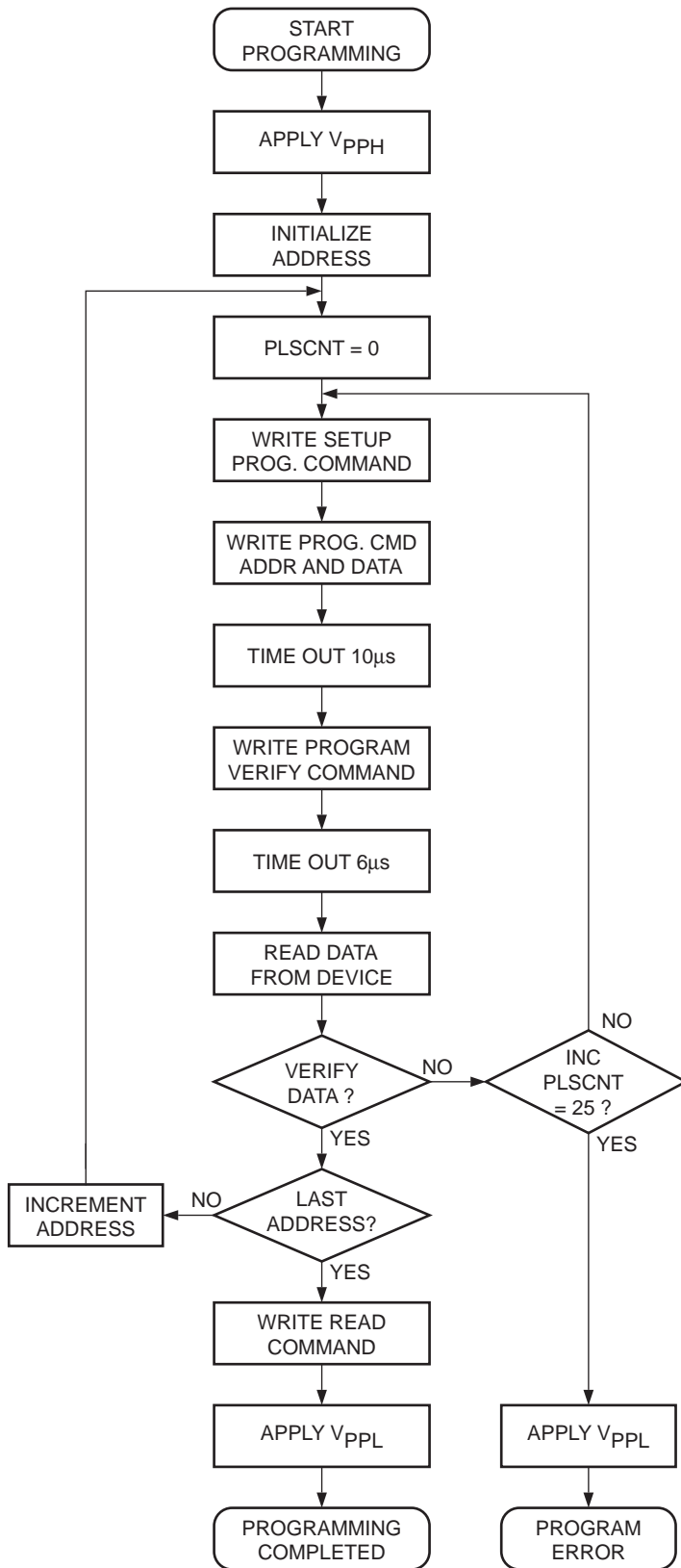

BUS OPERATION	COMMAND	COMMENTS
STANDBY		V _{pp} RAMPS TO V _{ppH} (OR V _{pp} HARDWIRED)
		INITIALIZE ADDRESS
		INITIALIZE PULSE COUNT PLSCNT = PULSE COUNT
1ST WRITE CYCLE	WRITE SETUP	DATA = XX40H
2ND WRITE CYCLE	PROGRAM	VALID ADDRESS AND DATA
		WAIT
1ST WRITE CYCLE	PROGRAM VERIFY	DATA = XXC0H
		WAIT
READ		READ BYTE TO VERIFY PROGRAMMING
STANDBY		COMPARE DATA OUTPUT TO DATA EXPECTED
1ST WRITE CYCLE	READ	DATA = XX00H SETS THE REGISTER FOR READ OPERATION
STANDBY		V _{pp} RAMPS TO V _{ppL} (OR V _{pp} HARDWIRED)

Note:

(1) The algorithm MUST BE FOLLOWED to ensure proper and reliable operation of the device.

Abort/Reset

An Abort/Reset command is available to allow the user to safely abort an erase or program sequence. Two consecutive program cycles with XXFFH on the data bus will abort an erase or a program operation. The abort/reset operation can interrupt at any time in a program or erase operation and the device is reset to the Read Mode.

DATA PROTECTION

1. Power Supply Voltage

When the power supply voltage (V_{CC}) is less than 2.5V, the device ignores \overline{WE} signal.

2. Write Inhibit

When \overline{CE} and \overline{OE} are terminated to the low level, write mode is not set.

POWER UP/DOWN PROTECTION

The CAT28F102 offers protection against inadvertent programming during V_{PP} and V_{CC} power transitions. When powering up the device there is no power-on sequencing necessary. In other words, V_{PP} and V_{CC} may power up in any order. Additionally V_{PP} may be hardwired to V_{PPH} independent of the state of V_{CC} and any power up/down cycling. The internal command register of the CAT28F102 is reset to the Read Mode on power up.

POWER SUPPLY DECOUPLING

To reduce the effect of transient power supply voltage spikes, it is good practice to use a 0.1 μ F ceramic capacitor between V_{CC} and V_{SS} and V_{PP} and V_{SS} . These high-frequency capacitors should be placed as close as possible to the device for optimum decoupling.

Figure 10. Alternate A.C. Timing for Program Operation

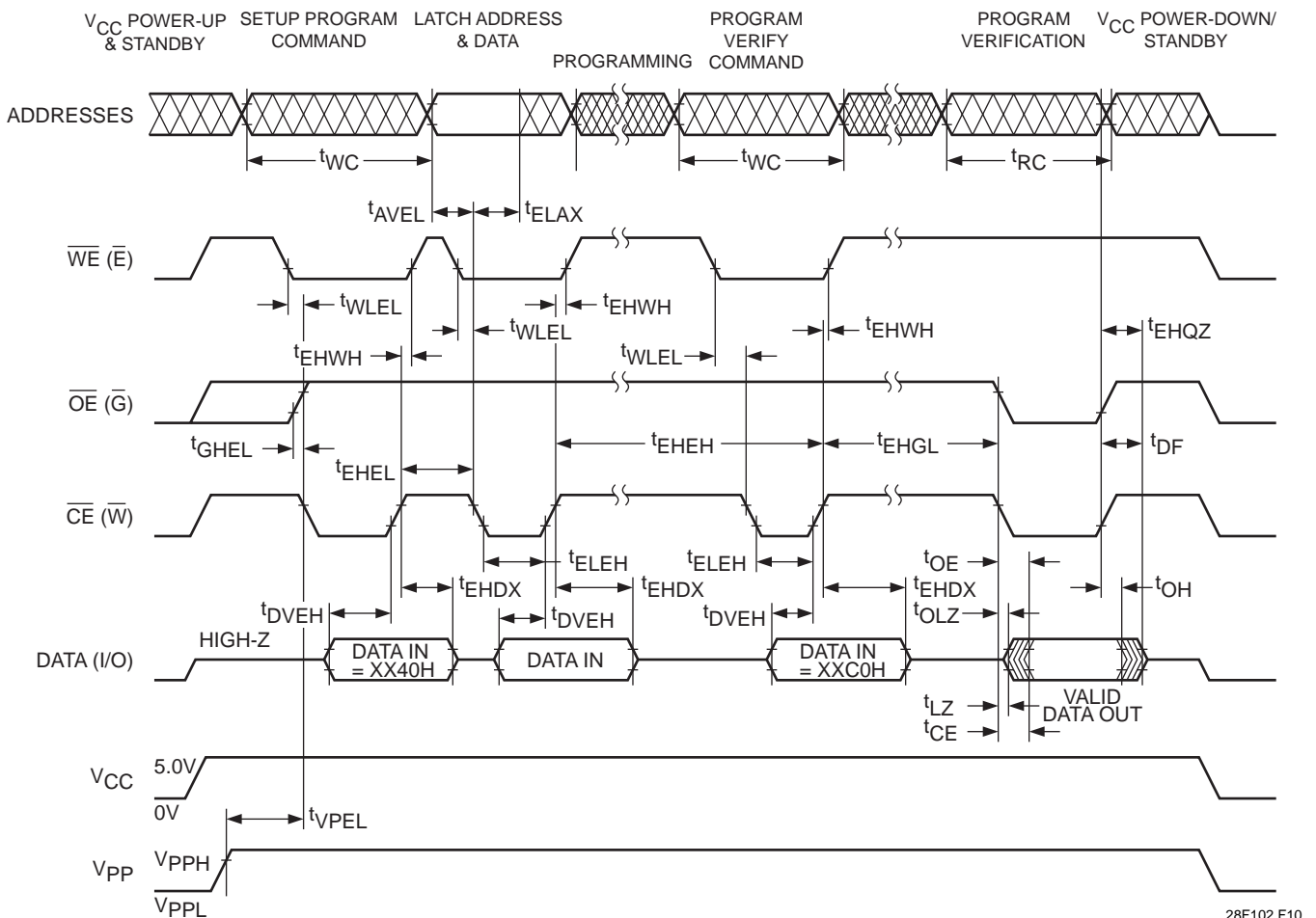

28F102 F10

ALTERNATE CE-CONTROLLED WRITES

V_{CC} = +5V ±10%, unless otherwise specified.

JEDEC Symbol	Standard Symbol	Parameter	28F102-45 V _{CC} = +5V ±5%		28F102-55 V _{CC} = +5V ±5%		28F102-70		28F102-90		Unit
			Min.	Max.	Min.	Max.	Min.	Max.	Min.	Max.	
t _{AVAV}	WC	Write Cycle Time	45		55		70		90		ns
t _{AVEL}	t _{AS}	Address Setup Time	0		0		0		0		ns
t _{ELAX}	t _{AH}	Address Hold Time	30		30		35		40		ns
t _{DVEH}	t _{DS}	Data Setup Time	30		30		35		40		ns
t _{EHDX}	t _{DH}	Data Hold Time	10		10		10		10		ns
t _{EHGL}	-	Write Recovery Time Before Read	6		6		6		6		µs
t _{GHEL}	-	Read Recovery Time Before Write	0		0		0		0		µs
t _{WLEL}	t _{WS}	\overline{WE} Setup Time Before \overline{CE}	0		0		0		0		ns
t _{EHWH}	t _{WH}	\overline{WE} Hold Time After \overline{CE}	0		0		0		0		ns
t _{ELEH}	t _{CP}	Write Pulse Width	30		30		35		40		ns
t _{EHEL}	t _{CPH}	Write Pulse Width High	20		20		20		20		ns
t _{VPEL}	-	V _{PP} Setup Time to \overline{CE} Low	100		100		100		100		ns

ORDERING INFORMATION

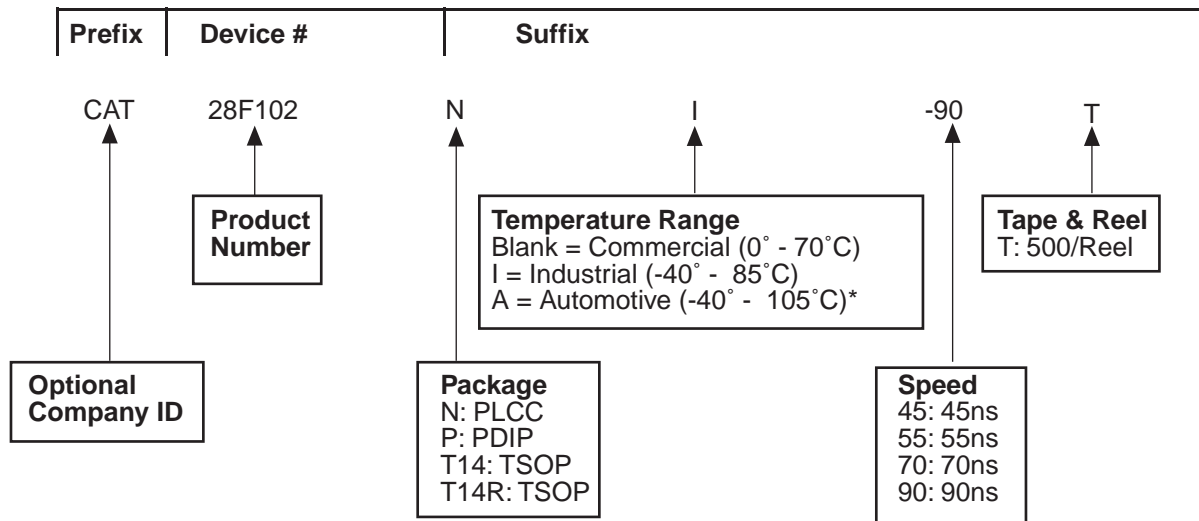

*-40° to + 125°C is available upon request

Note:

(1) The device used in the above example is a CAT28F102NI-90T (PLCC, Industrial Temperature, 90 ns access time, Tape & Reel).

This datasheet has been downloaded from:

www.DatasheetCatalog.com

Datasheets for electronic components.



LittleDiode supplies new, hard to find or obsolete electronic components and semiconductors all over the world.

With over two million different components listed you are sure to find the part you need.

Feel free to visit us today at our online store:

LittleDiode.com

Looking forward to providing you with the best possible service.