

DATA SHEET

CBT3245A Octal bus switch

Product data
Supersedes data of 2002 Feb 18

2003 Jun 27

Octal bus switch

CBT3245A

FEATURES

- Standard '245-type pinout
- 5 Ω switch connection between two ports
- TTL compatible control input levels
- Package options include plastic small outline (D), shrink small outline (DB), thin shrink small outline (TSSOP)
- Latch-up protection exceeds 500 mA per JESD78
- ESD protection exceeds 2000 V HBM per JESD22-A114, 150 V MM per JESD22-A115 and 1000 V CDM per JESD22-C101

DESCRIPTION

The CBT3245A provides eight bits of high-speed TTL-compatible bus switching in a standard '245 device pinout. The low on-state resistance of the switch allows connections to be made with minimal propagation delay.

The CBT3245A device is organized as one 8-bit switch. When enable (\overline{OE}) is LOW, the switch is on and port A is connected to port B. When \overline{OE} is HIGH, the switch is open and a high-impedance state exists between the two ports.

The CBT3245A is characterized for operation from -40 to +85 °C.

PIN CONFIGURATION — SO, SSOP, QSOP, AND TSSOP

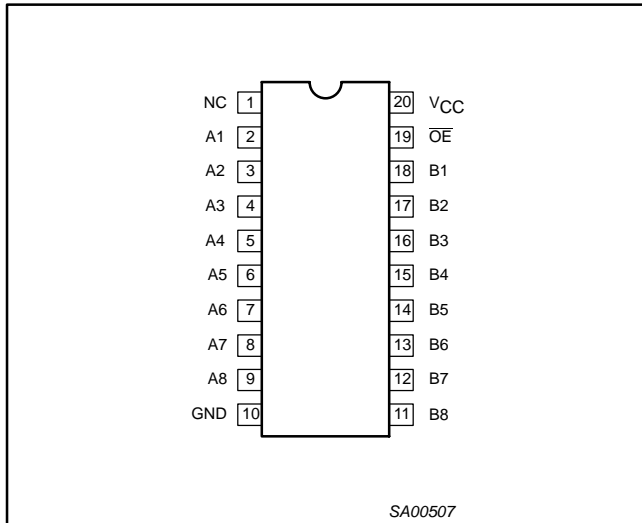

Figure 1. Pin configuration — SO, SSOP, QSOP, and TSSOP

PIN CONFIGURATION — DHVQFN

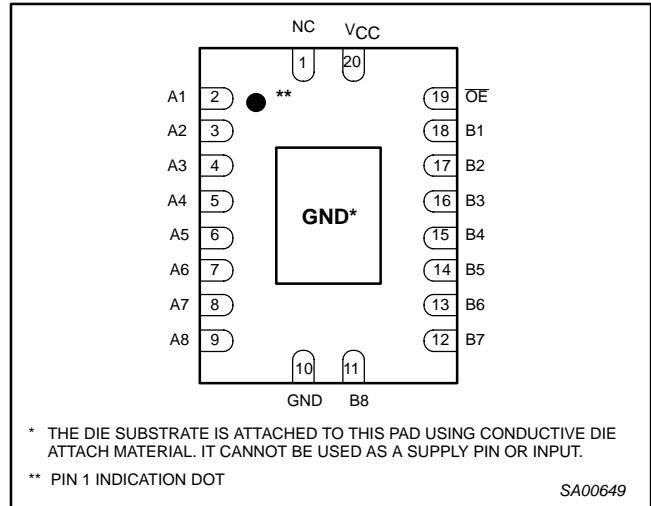

Figure 2. Pin configuration — DHVQFN (top view)

PIN DESCRIPTION

PIN NUMBER	SYMBOL	NAME AND FUNCTION
1	NC	No internal connection
19	\overline{OE}	Output enable input
2, 3, 4, 5, 6, 7, 8, 9	A1-A8	Inputs
18, 17, 16, 15, 14, 13, 12, 11	B1-B8	Outputs
10	GND	Ground (0V)
20	V _{CC}	Positive supply voltage

ORDERING INFORMATION

PACKAGES	TEMPERATURE RANGE	ORDER CODE	TOPSIDE MARK	DWG NUMBER
20-Pin Plastic DHVQFN	-40 to 85 °C	CBT3245ABQ	CT3245A	SOT764-1
20-Pin Plastic TSSOP	-40 to 85 °C	CBT3245APW	CT3245A	SOT360-1
20-Pin Plastic SSOP (QSOP)	-40 to 85 °C	CBT3245ADS	CT3245ADS	SOT724-1
20-Pin Plastic SSOP	-40 to 85 °C	CBT3245ADB	CT3245A	SOT339-1
20-Pin Plastic SO	-40 to 85 °C	CBT3245AD	CBT3245AD	SOT163-1

Standard packing quantities and other packaging data is available at www.philipslogic.com/packaging.

Octal bus switch

CBT3245A

LOGIC SYMBOL

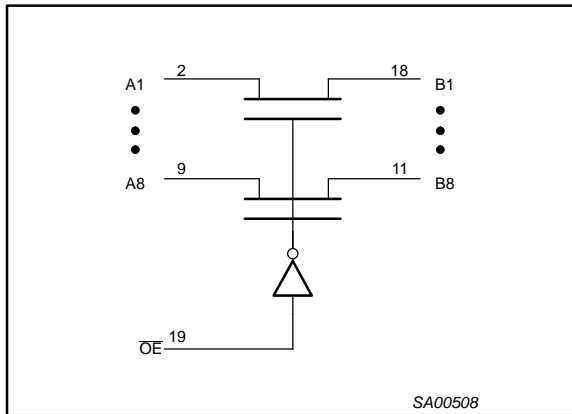

FUNCTION TABLE

INPUT	INPUTS/OUTPUTS
\overline{OE}	A, B
L	A = B
H	Z

H = HIGH voltage level
 L = LOW voltage level
 Z = HIGH impedance "off" state

ABSOLUTE MAXIMUM RATINGS^{1, 2}

SYMBOL	PARAMETER	CONDITIONS	RATING	UNIT
V_{CC}	DC supply voltage		-0.5 to +7.0	V
I_{IK}	DC input diode current	$V_I < 0$	-50	mA
V_I	DC input voltage ³		-0.5 to +7.0	V
I_{OK}	DC output diode current	$V_O < 0$	-50	mA
V_{OUT}	DC output voltage ³	output in Off or HIGH state	-0.5 to +7	V
I_{OUT}	DC output current	output in LOW state	128	mA
T_{stg}	Storage temperature range		-65 to 150	°C

NOTES:

- Stresses beyond those listed may cause permanent damage to the device. These are stress ratings only and functional operation of the device at these or any other conditions beyond those indicated under "recommended operating conditions" is not implied. Exposure to absolute-maximum-rated conditions for extended periods may affect device reliability.
- The performance capability of a high-performance integrated circuit in conjunction with its thermal environment can create junction temperatures which are detrimental to reliability. The maximum junction temperature of this integrated circuit should not exceed 150 °C.
- The input and output voltage ratings may be exceeded if the input and output current ratings are observed.

RECOMMENDED OPERATING CONDITIONS

SYMBOL	PARAMETER	LIMITS		UNIT
		MIN	MAX	
V_{CC}	DC supply voltage	4.0	5.5	V
V_{IH}	HIGH-level input voltage	2.0	—	V
V_{IL}	LOW-level input voltage	—	0.8	V
T_{amb}	Operating free-air temperature range	-40	+85	°C

Octal bus switch

CBT3245A

DC ELECTRICAL CHARACTERISTICS

SYMBOL	PARAMETER	TEST CONDITIONS	LIMITS			UNIT
			$T_{amb} = -40 \text{ to } +85 \text{ } ^\circ\text{C}$			
			MIN	TYP ¹	MAX	
V_{IK}	Input clamp voltage	$V_{CC} = 4.5 \text{ V}; I_I = -18 \text{ mA}$	—	—	-1.2	V
I_I	Input leakage current	$V_{CC} = 5.5 \text{ V}; V_I = \text{GND or } 5.5 \text{ V}$	—	—	± 5	μA
I_{CC}	Quiescent supply current	$V_{CC} = 5.5 \text{ V}; I_O = 0, V_I = V_{CC} \text{ or GND}$	—	1	3	μA
ΔI_{CC}	Additional supply current per input pin ²	$V_{CC} = 5.5 \text{ V}$, one input at 3.4 V, other inputs at V_{CC} or GND	—	—	3.5	mA
C_I	Control pins	$V_I = 3 \text{ V or } 0, \overline{OE} = V_{CC}$	—	3.2	—	pF
$C_{IO(OFF)}$	Pin capacitance (OFF state)	$V_O = 3 \text{ V or } 0$	—	6.6	—	pF
r_{on}^3	On-resistance	$V_{CC} = 4.5 \text{ V}; V_I = 0 \text{ V}; I_I = 64 \text{ mA}$	—	5	7	Ω
		$V_{CC} = 4.5 \text{ V}; V_I = 0 \text{ V}; I_I = 30 \text{ mA}$	—	5	7	
		$V_{CC} = 4.5 \text{ V}; V_I = 2.4 \text{ V}; I_I = 15 \text{ mA}$	—	10	15	

NOTES:

- All typical values are at $V_{CC} = 5 \text{ V}$, $T_{amb} = 25 \text{ } ^\circ\text{C}$
- This is the increase in supply current for each input that is at the specified TTL voltage level rather than V_{CC} or GND
- Measured by the voltage drop between the A and the B terminals at the indicated current through the switch.
On-state resistance is determined by the lowest voltage of the two (A or B) terminals.

AC CHARACTERISTICS

GND = 0 V; t_R ; $C_L = 50 \text{ pF}$

SYMBOL	PARAMETER	FROM (INPUT)	TO (OUTPUT)	CBT3245A		UNIT
				$T_{amb} = -40 \text{ to } +85 \text{ } ^\circ\text{C}$ $V_{CC} = +5.0 \text{ V } \pm 0.5 \text{ V}$		
				MIN	MAX	
t_{pd}	Propagation delay ¹	A or B	B or A	—	0.25	ns
t_{en}	Output enable time to HIGH and LOW level	\overline{OE}	A or B	1.0	5.9	ns
t_{dis}	Output disable time from HIGH and LOW level	\overline{OE}	A or B	1.0	6.0	ns

NOTES:

- This parameter is warranted but not production tested. The propagation delay is based on the RC time constant of the typical on-state resistance of the switch and a load capacitance of 50 pF, when driven by an ideal voltage source (zero output impedance).

Octal bus switch

CBT3245A

AC WAVEFORMS

$V_M = 1.5\text{ V}$, $V_{IN} = \text{GND to } 3.0\text{ V}$

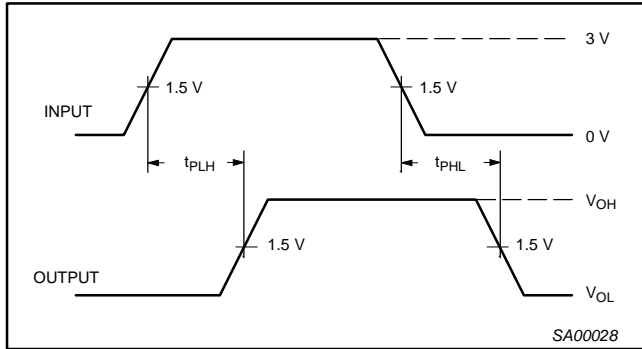

Waveform 1. Input to Output Propagation Delays

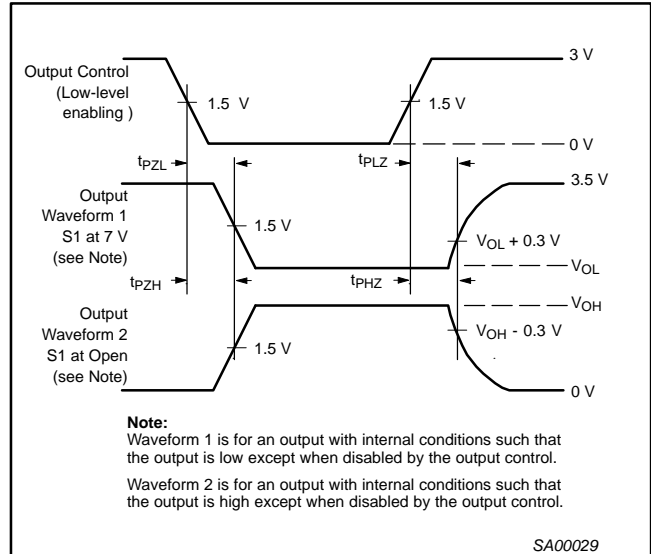

Waveform 2. 3-State Output Enable and Disable Times

TEST CIRCUIT AND WAVEFORMS

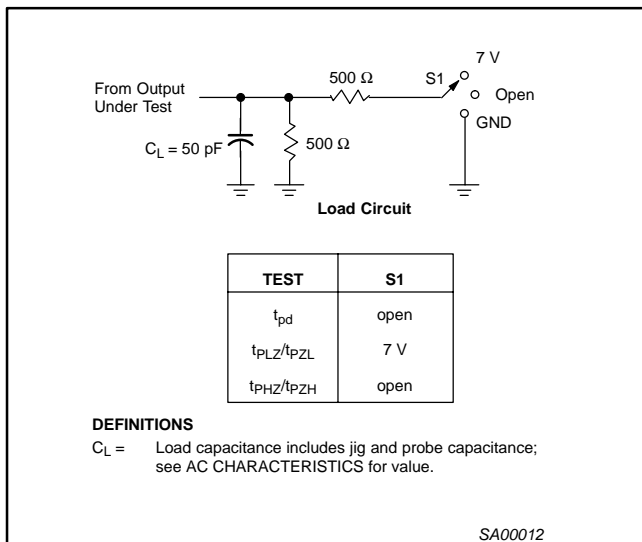

NOTES:

1. All input pulses are supplied by generators having the following characteristics: $PRR \leq 10\text{ MHz}$, $Z_O = 50\ \Omega$, $t_r \leq 2.5\text{ ns}$, $t_f \leq 2.5\text{ ns}$.
2. The outputs are measured one at a time with one transition per measurement.

Octal bus switch

CBT3245A

DHVQFN20: plastic dual in-line compatible thermal enhanced very thin quad flat package;
no leads; 20 terminals; body 2.5 x 4.5 x 0.85 mm

SOT764-1

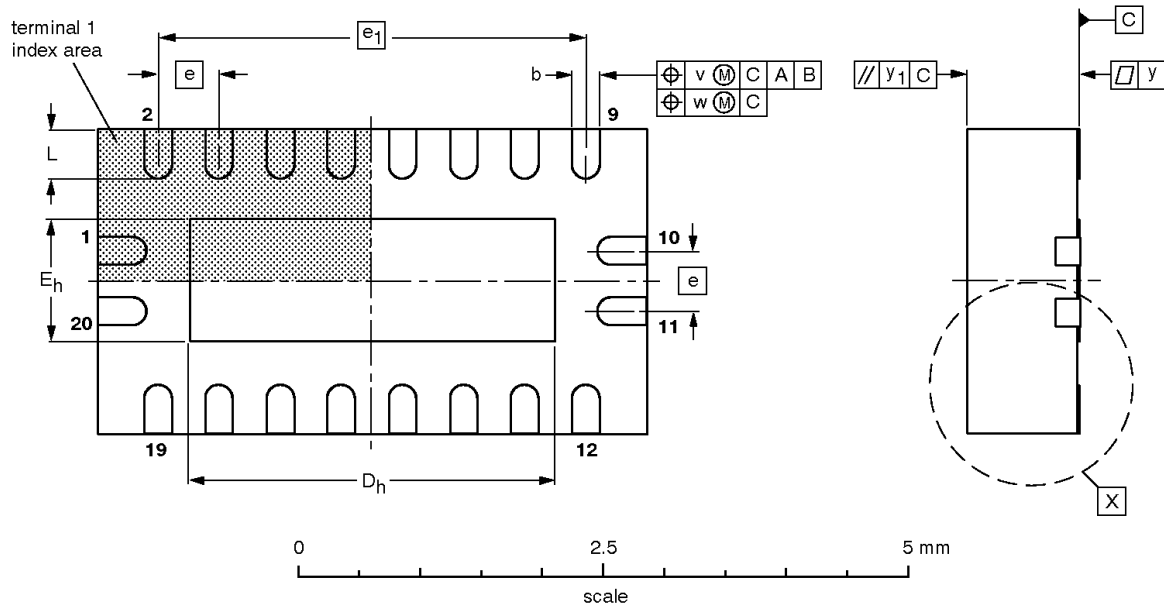
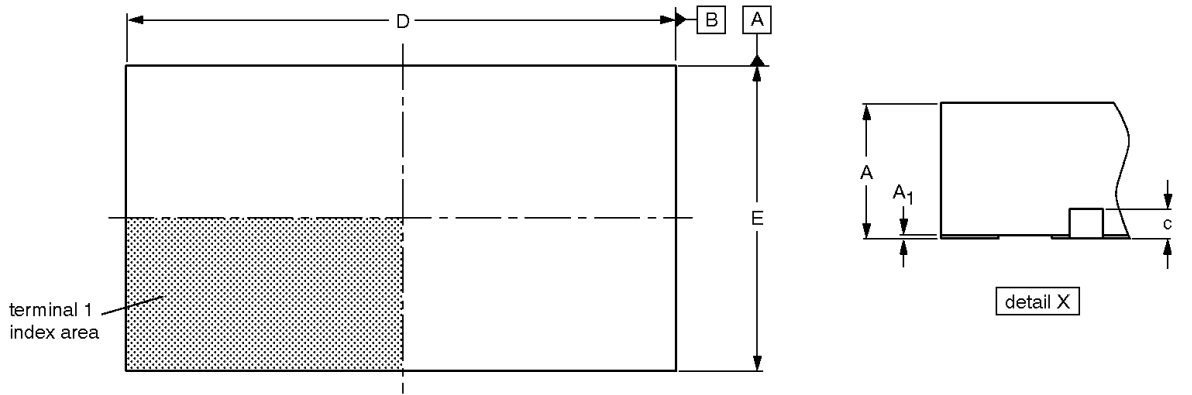

DIMENSIONS (mm are the original dimensions)

UNIT	A ⁽¹⁾ max.	A ₁	b	c	D ⁽¹⁾	D _h	E ⁽¹⁾	E _h	e	e ₁	L	v	w	y	y ₁
mm	1	0.05 0.00	0.30 0.18	0.2	4.6 4.4	3.15 2.85	2.6 2.4	1.15 0.85	0.5	3.5	0.5 0.3	0.1	0.05	0.05	0.1

Note

1. Plastic or metal protrusions of 0.075 mm maximum per side are not included.

OUTLINE VERSION	REFERENCES				EUROPEAN PROJECTION	ISSUE DATE
	IEC	JEDEC	JEITA			
SOT764-1	---	MO-241	---			02-10-17 03-01-27

Octal bus switch

CBT3245A

TSSOP20: plastic thin shrink small outline package; 20 leads; body width 4.4 mm

SOT360-1

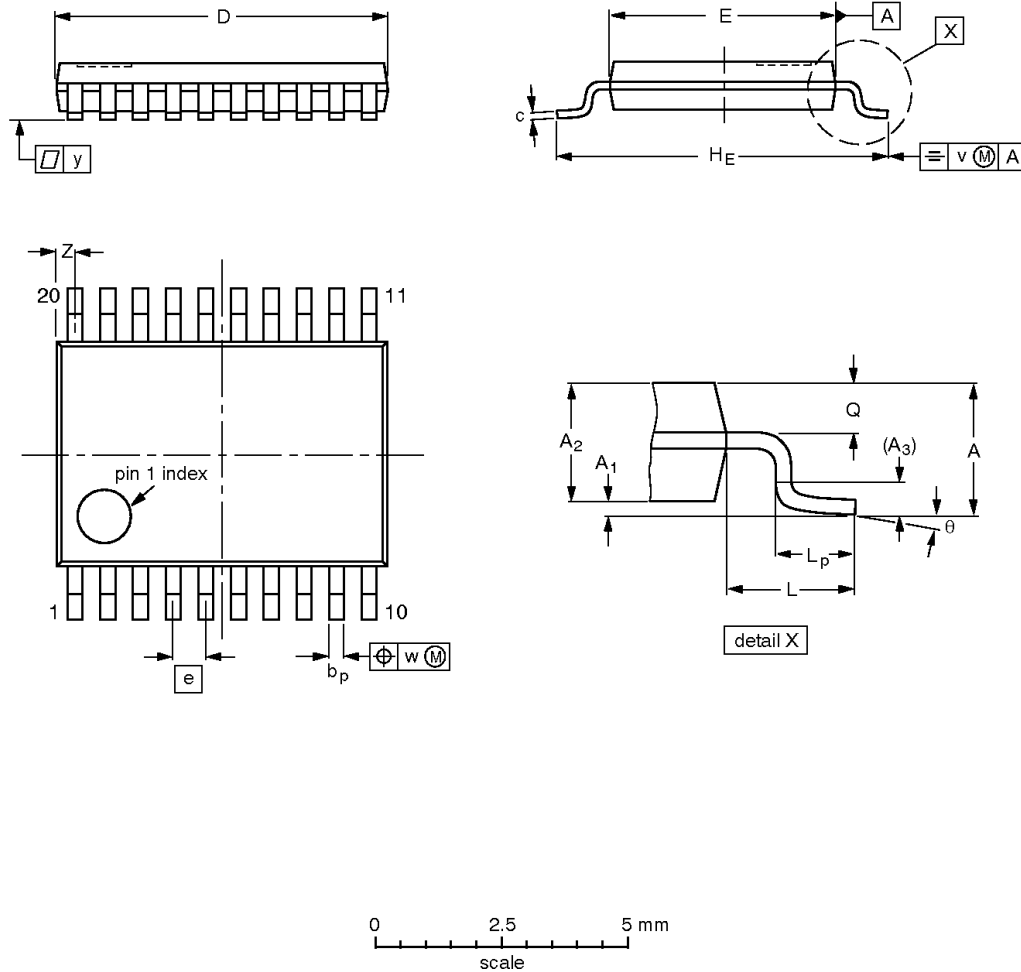

DIMENSIONS (mm are the original dimensions)

UNIT	A max.	A ₁	A ₂	A ₃	b _p	c	D ⁽¹⁾	E ⁽²⁾	e	H _E	L	L _p	Q	v	w	y	Z ⁽¹⁾	θ
mm	1.1	0.15 0.05	0.95 0.80	0.25	0.30 0.19	0.2 0.1	6.6 6.4	4.5 4.3	0.65	6.6 6.2	1	0.75 0.50	0.4 0.3	0.2	0.13	0.1	0.5 0.2	8° 0°

Notes

1. Plastic or metal protrusions of 0.15 mm maximum per side are not included.
2. Plastic interlead protrusions of 0.25 mm maximum per side are not included.

OUTLINE VERSION	REFERENCES				EUROPEAN PROJECTION	ISSUE DATE
	IEC	JEDEC	JEITA			
SOT360-1		MO-153				99-12-27 03-02-19

Octal bus switch

CBT3245A

SSOP20: plastic shrink small outline package; 20 leads;
body width 3.9 mm; lead pitch 0.635 mm

SOT724-1

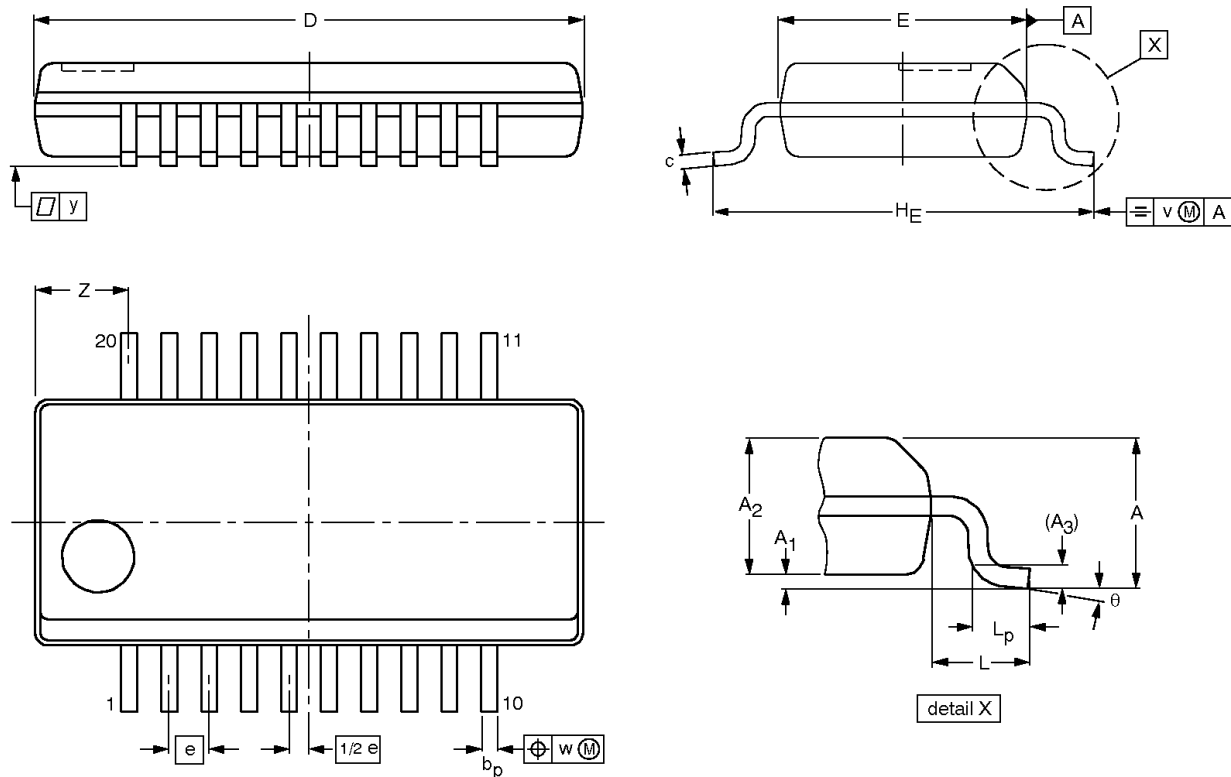

DIMENSIONS (millimetre dimensions are derived from the original inch dimensions)

UNIT	A max.	A ₁	A ₂	A ₃	b _p	c	D ⁽¹⁾	E ⁽¹⁾	e	H _E	L	L _p	v	w	y	Z ⁽¹⁾	θ
mm	1.73	0.25 0.10	1.55 1.40	0.25	0.31 0.20	0.25 0.18	8.8 8.6	4.0 3.8	0.635	6.2 5.8	1	0.89 0.41	0.25	0.18	0.1	1.67 1.28	8° 0°

Note

1. Plastic or metal protrusions of 0.2 mm maximum per side are not included.

OUTLINE VERSION	REFERENCES				EUROPEAN PROJECTION	ISSUE DATE
	IEC	JEDEC	JEITA			
SOT724-1		MO-137				01-07-04 03-02-18

Octal bus switch

CBT3245A

SSOP20: plastic shrink small outline package; 20 leads; body width 5.3 mm

SOT339-1

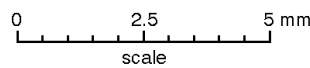
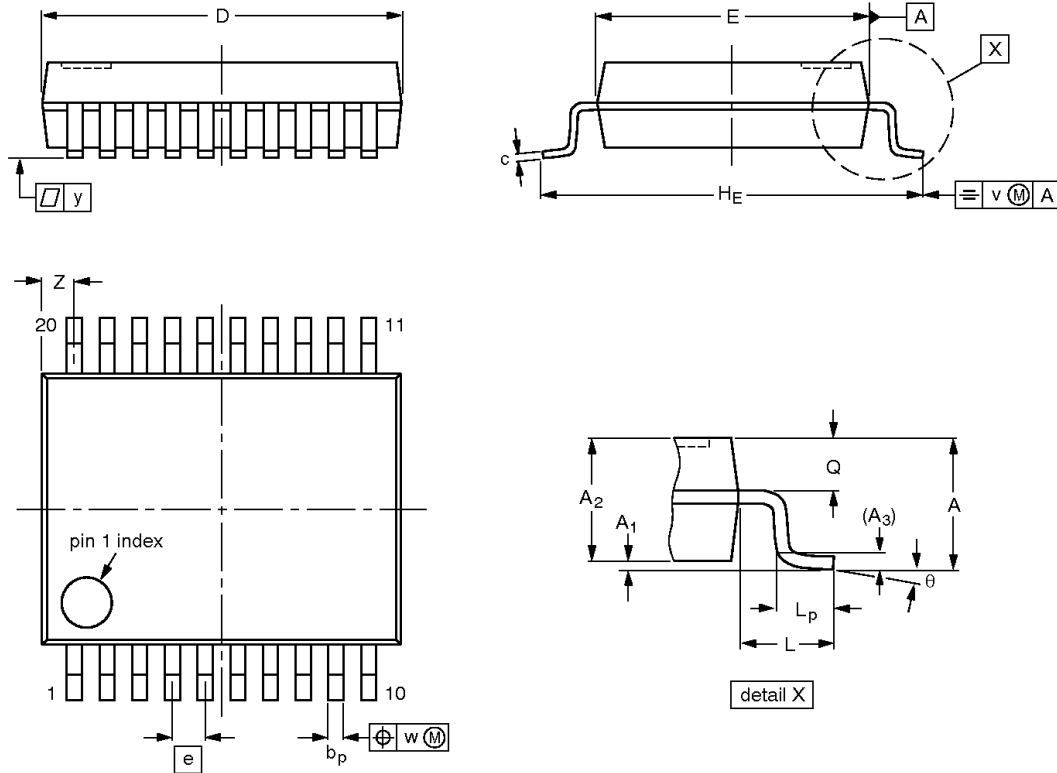

DIMENSIONS (mm are the original dimensions)

UNIT	A max.	A ₁	A ₂	A ₃	b _p	c	D ⁽¹⁾	E ⁽¹⁾	e	H _E	L	L _p	Q	v	w	y	Z ⁽¹⁾	θ
mm	2	0.21 0.05	1.80 1.65	0.25	0.38 0.25	0.20 0.09	7.4 7.0	5.4 5.2	0.65	7.9 7.6	1.25	1.03 0.63	0.9 0.7	0.2	0.13	0.1	0.9 0.5	8° 0°

Note

1. Plastic or metal protrusions of 0.2 mm maximum per side are not included.

OUTLINE VERSION	REFERENCES				EUROPEAN PROJECTION	ISSUE DATE
	IEC	JEDEC	JEITA			
SOT339-1		MO-150				99-12-27 03-02-19

Octal bus switch

CBT3245A

SO20: plastic small outline package; 20 leads; body width 7.5 mm

SOT163-1

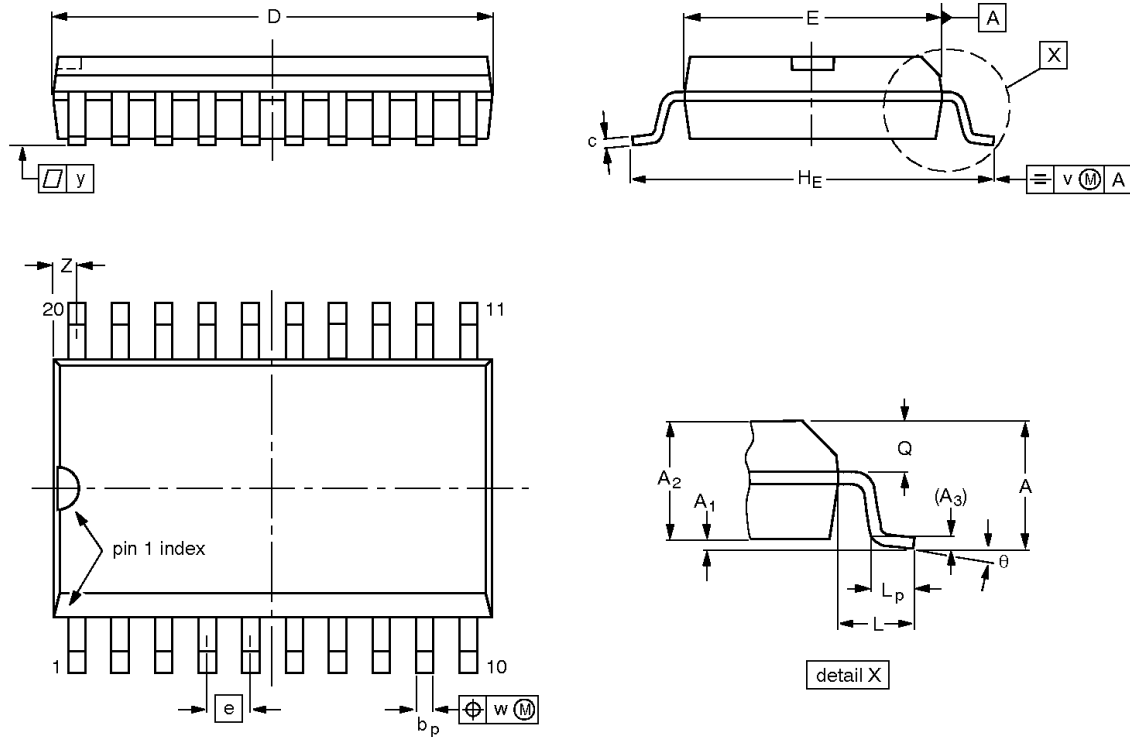

DIMENSIONS (inch dimensions are derived from the original mm dimensions)

UNIT	A max.	A ₁	A ₂	A ₃	b _p	c	D ⁽¹⁾	E ⁽¹⁾	e	HE	L	L _p	Q	v	w	y	Z ⁽¹⁾	θ
mm	2.65	0.3 0.1	2.45 2.25	0.25	0.49 0.36	0.32 0.23	13.0 12.6	7.6 7.4	1.27	10.65 10.00	1.4	1.1 0.4	1.1 1.0	0.25	0.25	0.1	0.9 0.4	8° 0°
inches	0.1	0.012 0.004	0.096 0.089	0.01	0.019 0.014	0.013 0.009	0.51 0.49	0.30 0.29	0.05	0.419 0.394	0.055	0.043 0.016	0.043 0.039	0.01	0.01	0.004	0.035 0.016	

Note

1. Plastic or metal protrusions of 0.15 mm (0.006 inch) maximum per side are not included.

OUTLINE VERSION	REFERENCES				EUROPEAN PROJECTION	ISSUE DATE
	IEC	JEDEC	JEITA			
SOT163-1	075E04	MS-013				99-12-27 03-02-19

Octal bus switch

CBT3245A

REVISION HISTORY

Rev	Date	Description
_2	20030627	Product data (9397 750 11679); ECN 853-2313 30017 dated 11 Jun 2003. Supersedes data of 2002 Feb 18 (9397 750 09462). Modifications: <ul style="list-style-type: none">• Addition of QSOP and DHVQFN package types.
_1	20020218	Product data (9397 750 09462); ECN 853-2313 27745 of 18 Feb 2002.

Octal bus switch

CBT3245A

Data sheet status

Level	Data sheet status ^[1]	Product status ^{[2] [3]}	Definitions
I	Objective data	Development	This data sheet contains data from the objective specification for product development. Philips Semiconductors reserves the right to change the specification in any manner without notice.
II	Preliminary data	Qualification	This data sheet contains data from the preliminary specification. Supplementary data will be published at a later date. Philips Semiconductors reserves the right to change the specification without notice, in order to improve the design and supply the best possible product.
III	Product data	Production	This data sheet contains data from the product specification. Philips Semiconductors reserves the right to make changes at any time in order to improve the design, manufacturing and supply. Relevant changes will be communicated via a Customer Product/Process Change Notification (CPCN).

[1] Please consult the most recently issued data sheet before initiating or completing a design.

[2] The product status of the device(s) described in this data sheet may have changed since this data sheet was published. The latest information is available on the Internet at URL <http://www.semiconductors.philips.com>.

[3] For data sheets describing multiple type numbers, the highest-level product status determines the data sheet status.

Definitions

Short-form specification — The data in a short-form specification is extracted from a full data sheet with the same type number and title. For detailed information see the relevant data sheet or data handbook.

Limiting values definition — Limiting values given are in accordance with the Absolute Maximum Rating System (IEC 60134). Stress above one or more of the limiting values may cause permanent damage to the device. These are stress ratings only and operation of the device at these or at any other conditions above those given in the Characteristics sections of the specification is not implied. Exposure to limiting values for extended periods may affect device reliability.

Application information — Applications that are described herein for any of these products are for illustrative purposes only. Philips Semiconductors make no representation or warranty that such applications will be suitable for the specified use without further testing or modification.

Disclaimers

Life support — These products are not designed for use in life support appliances, devices, or systems where malfunction of these products can reasonably be expected to result in personal injury. Philips Semiconductors customers using or selling these products for use in such applications do so at their own risk and agree to fully indemnify Philips Semiconductors for any damages resulting from such application.

Right to make changes — Philips Semiconductors reserves the right to make changes in the products—including circuits, standard cells, and/or software—described or contained herein in order to improve design and/or performance. When the product is in full production (status 'Production'), relevant changes will be communicated via a Customer Product/Process Change Notification (CPCN). Philips Semiconductors assumes no responsibility or liability for the use of any of these products, conveys no license or title under any patent, copyright, or mask work right to these products, and makes no representations or warranties that these products are free from patent, copyright, or mask work right infringement, unless otherwise specified.

Contact information

For additional information please visit
<http://www.semiconductors.philips.com>. Fax: +31 40 27 24825

© Koninklijke Philips Electronics N.V. 2003
 All rights reserved. Printed in U.S.A.

Date of release: 06-03

For sales offices addresses send e-mail to:
sales.addresses@www.semiconductors.philips.com.

Document order number:

9397 750 11679

Let's make things better.



LittleDiode supplies new, hard to find or obsolete electronic components and semiconductors all over the world.

With over two million different components listed you are sure to find the part you need.

Feel free to visit us today at our online store:

LittleDiode.com

Looking forward to providing you with the best possible service.