

February 1999

**OBSOLETE PRODUCT
NO RECOMMENDED REPLACEMENT**
Call Central Applications 1-800-442-7747
or email: centapp@harris.com

CMOS 4 x 4 x 2 Crosspoint Switch with Control Memory

Features

- Low ON Resistance 75Ω (Typ) at V_{DD} = 12V
- “Built - In” Latched Inputs
- Large Analog Signal Capability ±V_{DD}/2
- Switch Bandwidth 10MHz
- Matched Switch Characteristics
ΔR_{ON} = 8Ω (Typ) at V_{DD} = 12V
- High Linearity - 0.25% Distortion (Typ) at f = 1kHz,
V_{IN} = 5V_{P-P}, V_{DD} - V_{SS} = 10V, and R_L = 1kΩ
- Standard CMOS Noise Immunity

Applications

- Telephone Systems
- PBX
- Studio Audio Switching
- Multisystem Bus Interconnect

Ordering Information

PART NUMBER	TEMP. RANGE (°C)	PACKAGE	PKG. NO.
CD22101E	-40 to 85	24 Ld PDIP	E24.6
CD22101F	-55 to 125	24 Ld CERDIP	F24.6
CD22102E	-40 to 85	24 Ld PDIP	E24.6

Description

CD22101 and CD22102 crosspoint switches consist of 4 x 4 x 2 arrays of crosspoints (transmission gates) with a 4-line to 16-line decoder and 16 latch circuits. Any one of the sixteen crosspoint pairs can be selected by applying the appropriate four-line address, corresponding crosspoints in each array are turned on and off simultaneously. Any number of crosspoints can be turned on simultaneously.

In the CD22101, the selected crosspoint pair can be turned on or off by applying a logic ONE or ZERO, respectively, to the data input, and applying a ONE to the strobe input. When the device is “powered up”, the states of the 16 switches are indeterminate. Therefore, all switches must be turned off by putting the strobe high, data-in low, and then addressing all switches in succession.

The selected pair of crosspoints in the CD22102 is turned on by applying a logic ONE to the K_A (set) input while a logic ZERO is on the K_B input, and turned off by applying a logic ONE to the K_B (reset) input while a logic ZERO is on the K_A input. In this respect, the control latches of the CD22102 are similar to SET/RESET flip-flops. They differ, however, in that the simultaneous application of ONes to the K_A and K_B inputs turns off (resets) all crosspoints. All crosspoints in both devices must be turned off as V_{DD} is applied.

Pinouts

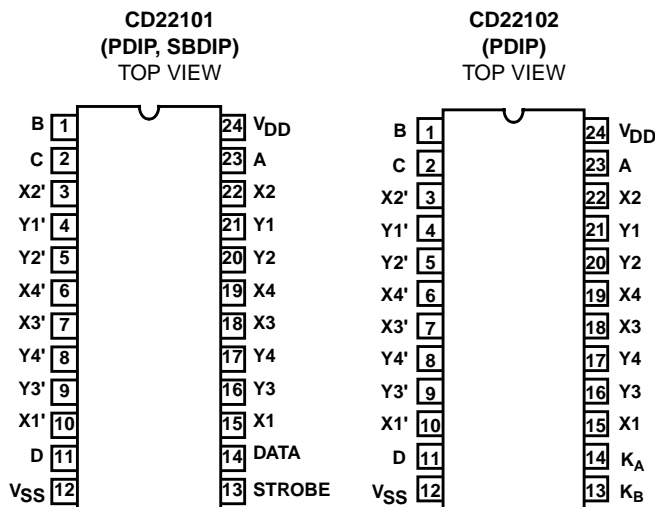

Functional Diagram

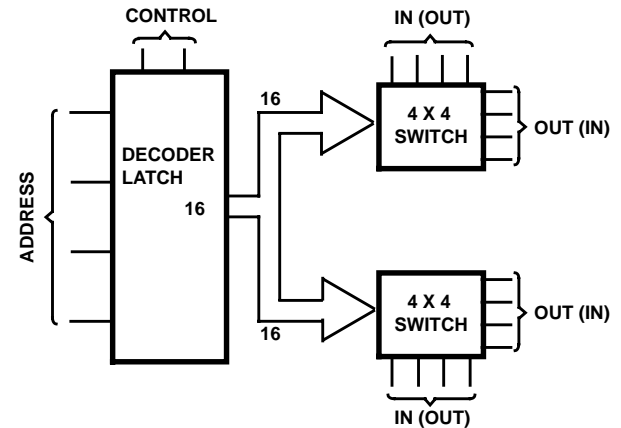

CD22101, CD22102

Absolute Maximum Ratings

Supply Voltage (V_{DD}) (Referenced to V_{SS} Terminal) -0.5 to 20V
 Input Voltage (All Inputs) -0.5 to $V_{DD} + 0.5V$
 Supply Voltage Range
 For T_A = Full Package Temperature Range 3V to 18V
 Input Current (Any One Input) (Note 1) $\pm 10mA$
 Power Dissipation
 For T_A = -40°C to 60°C (Package Type E) 500mW
 For T_A = 60°C to 85°C
 Package Type E) Derate Linearly 12mW/°C to 200mW
 For T_A = -55°C to 100°C (Package Type D, F) 500mW
 For T_A = 100°C to 125°C
 (Package Type D, F) Derate Linearly 12mW/°C to 200mW
 Device Dissipation per Output Transistor
 For T_A = Full Package Temperature Range (All Types) 100mW

Thermal Information

Maximum Junction Temperature 175°C
 Maximum Junction Temperature (Plastic Package) 150°C
 Maximum Storage Temperature Range $-65^\circ C \leq T_A \leq 150^\circ C$
 Maximum Lead Temperature (Soldering 10s) 300°C

Operating Conditions

Temperature Range
 Package Type D, F $-55^\circ C \leq T_A \leq 125^\circ C$
 Package Type E $-40^\circ C \leq T_A \leq 85^\circ C$

CAUTION: Stresses above those listed in "Absolute Maximum Ratings" may cause permanent damage to the device. This is a stress only rating and operation of the device at these or any other conditions above those indicated in the operational sections of this specification is not implied.

Electrical Specifications

Values at -55°C, 25°C, 125°C Apply to D, F, H Packages
 Values at -40°C, 25°C, 85°C Apply to E Package

PARAMETER	SYMBOL	TEST CONDITIONS		-55°C	-40°C	85°C	125°C	25°C			UNITS	
		FIGURE	$V_{DD}(V)$					MAX	MAX	MAX		MIN
STATIC CROSSPOINTS												
Quiescent Device Current	I_{DD} (Max)		1	5	5	5	150	150	-	0.04	5	μA
			1	10	10	10	300	300	-	0.04	10	μA
			1	15	20	20	600	600	-	0.04	20	μA
			1	20	100	100	3000	3000	-	0.08	100	μA
On Resistance	R_{ON} (Max)	Any Switch $V_{IS} = 0$ to V_{DD}	14	5	475	500	725	800	-	225	600	Ω
			15	10	135	145	205	230	-	85	180	Ω
			-	12	100	110	155	175	-	75	135	Ω
			16	15	70	75	110	125	-	65	95	Ω
Δ_{ON} Resistance	ΔR_{ON}	Between Any Two Switches	5		-	-	-	-	-	25	-	Ω
			10		-	-	-	-	-	10	-	Ω
			12		-	-	-	-	-	8	-	Ω
			15		-	-	-	-	-	5	-	Ω
OFF Leakage Current	I_L (Max)	All Switches OFF, $V_{IS} = 18V$	4	18	± 1000			-	± 1	± 100 (Note 2)	nA	
STATIC CONTROLS												
Input Low Voltage	V_{IL} (Max)	OFF Switch $I_L < 0.2\mu A$	5		1.5			-	-	1.5	V	
			10		3			-	-	3	V	
			15		4			-	-	4	V	
Input High Voltage	V_{IH} (Min)	ON Switch See R_{ON} Characteristic	5		3.5			3.5	-	-	V	
			10		7			7	-	-	V	
			15		11			11	-	-	V	
Input Current	I_{IN} (Max)	Any Control $V_{IN} = 0, 18V$	2	18	± 0.1	± 0.1	± 1	± 1	-	$\pm 10^{-5}$	± 0.1	μA

NOTES:

- Maximum current through transmission gates (switches) = 25mA.
- Determined by minimum feasible leakage measurement for automatic testing.

CD22101, CD22102

Electrical Specifications $T_A = 25^\circ\text{C}$

PARAMETER	SYMBOL	TEST CONDITIONS				MIN	TYP	MAX	UNITS	
		FIGURE	f_{IS} (kHz)	R_L (k Ω)	V_{IS} (V) (Note 3)					V_{DD} (V)
DYNAMIC CROSSPOINTS										
Propagation Delay Time, (Switch ON) Signal Input to Output	t_{PHL}, t_{PLH}	5	-	-	5	5	-	30	60	ns
			-	10	10	10	-	15	30	ns
					15	15	-	10	20	ns
			$C_L = 50\text{pF}; t_R, t_F = 20\text{ns}$							
Frequency Response (Any Switch ON)	f_{3dB}	19	1	1	5	10	-	40	-	MHz
			Sine Wave Input, $20\log\frac{V_{OS}}{V_{IS}} = -3\text{dB}$							
Sine Wave Response (Distortion)	THD	-	1	1	2.5	5	-	1	-	%
			1	1	5	10	-	0.25	-	%
			1	1	7.5	15	-	0.15	-	%
Feedthrough (All Switches OFF)	F_{DT}	13	1.6	0.6	2 (Note 4)	10	-	-96	-	dB
			Sine Wave Input							
Frequency for Signal Crosstalk Attenuation of 40dB	F_{CT}	12	-	0.6	1 (Note 4)	10	-	2.5	-	MHz
			Sine Wave Input					0.1		
Capacitance:										
X_N to Ground	C_{IS}			-	-	-	-	25	-	pF
Y_N to Ground				-	-	-	-	60	-	pF
Feedthrough	C_{IOS}			-	-	-	-	0.6	-	pF
DYNAMIC CONTROLS										
Propagation Delay Time: High Impedance to High Level or Low Level Strobe to Output, CD22101	t_{PZH}, t_{PZL}	6	$R_L = 1\text{k}\Omega, C_L = 50\text{pF}, t_R, t_F = 20\text{ns}$			5	-	500	1000	ns
						10	-	230	460	ns
						15	-	170	340	ns
Data-In to Output, CD22101	t_{PZH}, t_{PZL}	7	$R_L = 1\text{k}\Omega, C_L = 50\text{pF}, t_R, t_F = 20\text{ns}$			5	-	515	1000	ns
						10	-	220	440	ns
						15	-	170	340	ns
K_A to Output, CD22102	t_{PZH}, t_{PZL}	-	$R_L = 1\text{k}\Omega, C_L = 50\text{pF}, t_R, t_F = 20\text{ns}$			5	-	500	1000	ns
						10	-	215	430	ns
						15	-	160	320	ns
Address to Output CD22101, CD22102	t_{PZH}, t_{PZL}	8	$R_L = 1\text{k}\Omega, C_L = 50\text{pF}, t_R, t_F = 20\text{ns}$			5	-	480	960	ns
						10	-	225	450	ns
						15	-	155	300	ns

CD22101, CD22102

Electrical Specifications $T_A = 25^\circ\text{C}$ (Continued)

PARAMETER	SYMBOL	TEST CONDITIONS				MIN	TYP	MAX	UNITS
		FIGURE	f_{IS} (kHz)	R_L (k Ω)	V_{IS} (V) (Note 3)				
Propagation Delay Time: High Level or Low Level to High Impedance Strobe to Output, CD22101	t_{PHZ}, t_{PLZ}	6	$R_L = 1\text{k}\Omega, C_L = 50\text{pF},$ $t_R, t_F = 20\text{ns}$	5	-	450	900	ns	
					10	-	200	400	ns
					15	-	135	270	ns
K_B to Output, CD22102	t_{PHZ}, t_{PLZ}	-	$R_L = 1\text{k}\Omega, C_L = 50\text{pF},$ $t_R, t_F = 20\text{ns}$	5	-	450	900	ns	
					10	-	200	400	ns
					15	-	130	260	ns
Data-In to Output, CD22101	t_{PHZ}, t_{PLZ}	-	$R_L = 1\text{k}\Omega, C_L = 50\text{pF},$ $t_R, t_F = 20\text{ns}$	5	-	450	900	ns	
					10	-	165	330	ns
					15	-	110	220	ns
$K_A \bullet K_B$ to Output, CD22102	t_{PHZ}, t_{PLZ}	-	$R_L = 1\text{k}\Omega, C_L = 50\text{pF},$ $t_R, t_F = 20\text{ns}$	5	-	280	560	ns	
					10	-	130	260	ns
					15	-	90	180	ns
Address to Output CD22101, CD22102	t_{PHZ}, t_{PLZ}	8	$R_L = 1\text{k}\Omega, C_L = 50\text{pF},$ $t_R, t_F = 20\text{ns}$	5	-	425	850	ns	
					10	-	190	380	ns
					15	-	130	260	ns
Minimum Strobe Pulse Width, CD22101	t_W	6	$R_L = 1\text{k}\Omega, C_L = 50\text{pF},$ $t_R, t_F = 20\text{ns}$	5	-	260	500	ns	
					10	-	120	240	ns
					15	-	80	160	ns
Address to Strobe Setup or Hold Times, CD22101	t_{SU}, t_H	9	$R_L = 1\text{k}\Omega, C_L = 50\text{pF},$ $t_R, t_F = 20\text{ns}$	5	-	-160	0	ns	
					10	-	-70	0	ns
					15	-	-50	0	ns
Strobe to Data-In Hold Time, CD22101	t_{HHL}, t_{HLH}	10	$R_L = 1\text{k}\Omega, C_L = 50\text{pF},$ $t_R, t_F = 20\text{ns}$	5	-	200	400	ns	
					10	-	80	160	ns
					15	-	60	120	ns
Address to K_A and K_B Setup or Hold Times, CD22102	t_{SU}, t_H	-	$R_L = 1\text{k}\Omega, C_L = 50\text{pF},$ $t_R, t_F = 20\text{ns}$	5	-	-160	0	ns	
					10	-	-70	0	ns
					15	-	-50	0	ns
Minimum $K_A \bullet K_B$ Pulse Width, CD22102	t_W	-	$R_L = 1\text{k}\Omega, C_L = 50\text{pF},$ $t_R, t_F = 20\text{ns}$	5	-	375	750	ns	
					10	-	160	320	ns
					15	-	110	220	ns
Minimum K_A Pulse Width, CD22102	t_W	-	$R_L = 1\text{k}\Omega, C_L = 50\text{pF},$ $t_R, t_F = 20\text{ns}$	5	-	425	850	ns	
					10	-	175	350	ns
					15	-	120	240	ns

CD22101, CD22102

Electrical Specifications $T_A = 25^\circ\text{C}$ (Continued)

PARAMETER	SYMBOL	FIGURE	TEST CONDITIONS				MIN	TYP	MAX	UNITS	
			f_{IS} (kHz)	R_L (k Ω)	V_{IS} (V) (Note 3)	V_{DD} (V)					
Minimum K_B Pulse Width, CD22102	t_w	-	$R_L = 1\text{k}\Omega$, $C_L = 50\text{pF}$, $t_R, t_F = 20\text{ns}$				5	-	200	400	ns
							10	-	90	180	ns
							15	-	70	140	ns
Control Crosstalk, Data-In, Address or Strobe to Output		11	100	10		5	-	75	-	mV _{PEAK}	
			Square Wave Input = 5V, $t_R, t_F = 20\text{ns}$, $R_S = 1\text{k}\Omega$								
Input Capacitance	C_{IN}		Any Control Input			-	-	5	7.5	pF	

NOTES:

3. Peak-to-peak voltage symmetrical about $\frac{V_{DD}}{2}$, unless otherwise specified.
4. RMS.

Functional Block Diagram

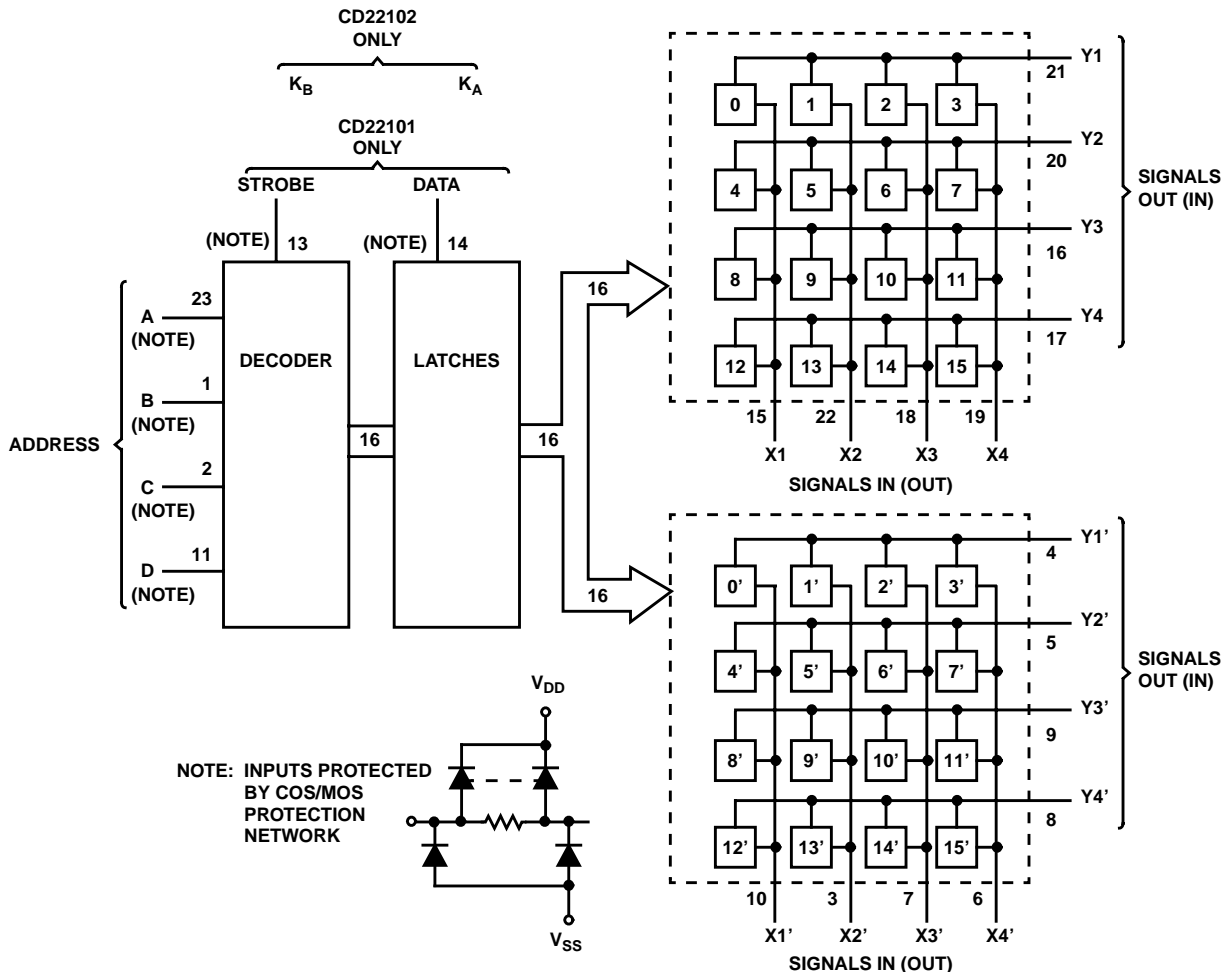

CD22101, CD22102

CONTROL TRUTH TABLE FOR CD22101

FUNCTION	ADDRESS				STROBE	DATA	SELECT
	A	B	C	D			
Switch ON	1	1	1	1	1	1	15 (X4Y4) and 15' (X4'Y4')
Switch OFF	1	1	1	1	1	0	15 (X4Y4) and 15' (X4'Y4')
No Change	X	X	X	X	0	X	X X X X

1 = High Level

0 = Low Level

X = Don't Care

CONTROL TRUTH TABLE FOR CD22102

FUNCTION	ADDRESS				K _A	K _B	SELECT
	A	B	C	D			
Switch ON	1	1	1	1	1	0	15 (X4Y4) and 15' (X4'Y4')
Switch OFF	1	1	1	1	0	1	15 (X4Y4) and 15' (X4'Y4')
All Switches OFF (Note 5)	X	X	X	X	1	1	All
No Change	X	X	X	X	0	0	X X X X

1 = High Level

0 = Low Level

X = Don't Care

NOTE:

5. In the event that K_A and K_B are changed from levels 1, 1 to 0, 0 K_B should not be allowed to go to 0 before K_A, otherwise a switch which was off will inadvertently be turned on.

Metallization Mask Layout

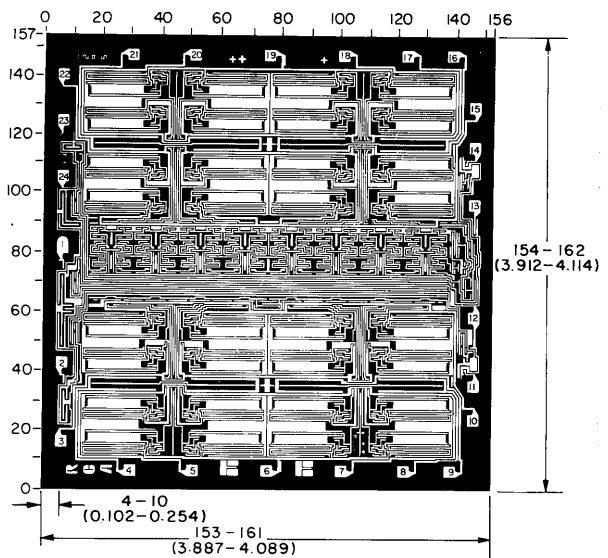
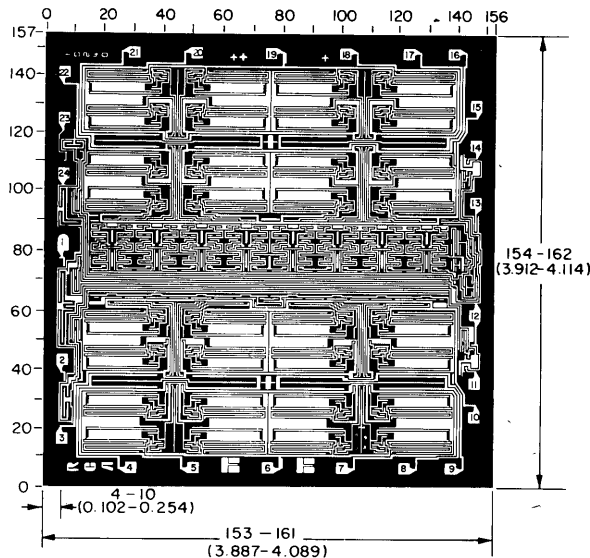

Dimensions in parenthesis are in millimeters and are derived from the basic inch dimensions as indicated. Grid graduations are in mils (10^{-3} inch).

Test Circuits and Waveforms

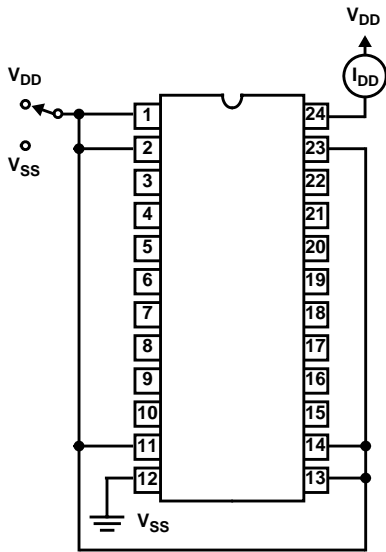
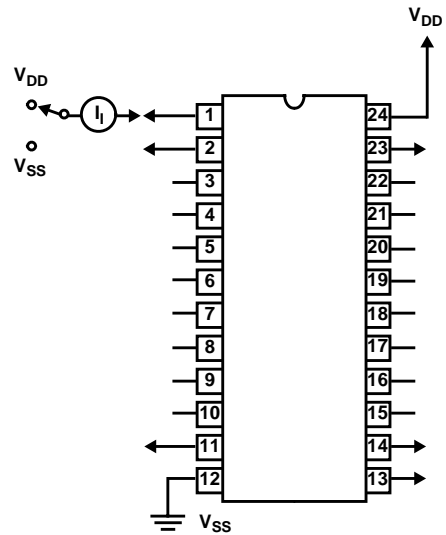

FIGURE 1. QUIESCENT CURRENT TEST CIRCUIT



MEASURE INPUTS SEQUENTIALLY TO BOTH V_{DD} AND V_{SS}
CONNECT ALL UNUSED INPUTS TO EITHER V_{DD} OR V_{SS}

FIGURE 2. INPUT CURRENT TEST CIRCUIT

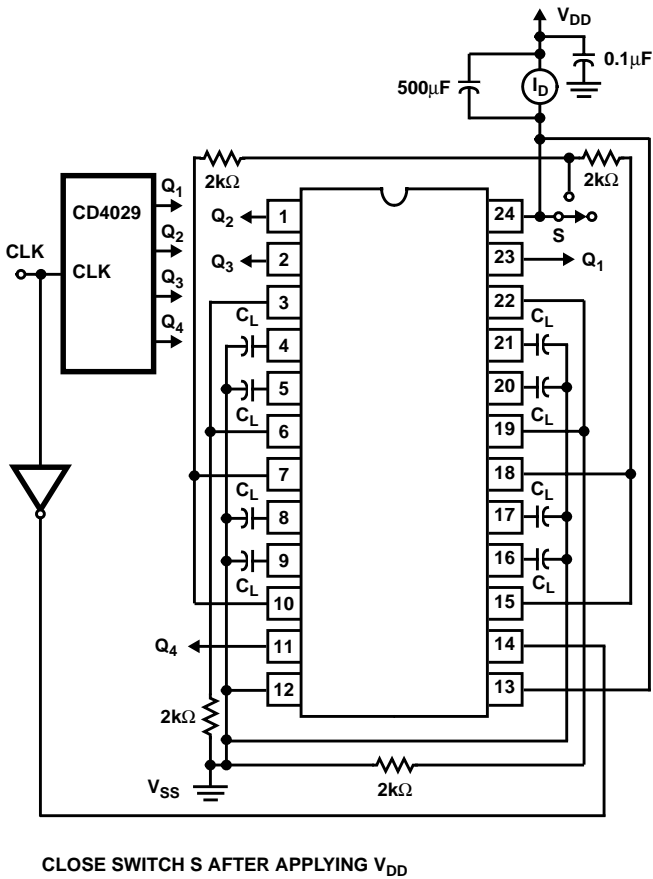
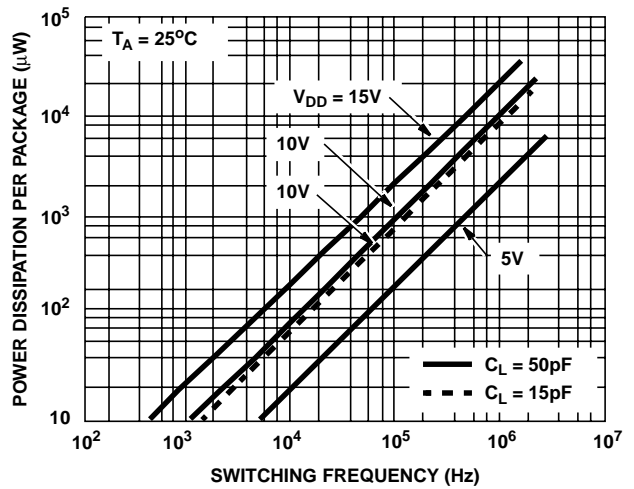

FIGURE 3. DYNAMIC POWER DISSIPATION TEST CIRCUIT FOR CD22101 AND TYPICAL DYNAMIC POWER DISSIPATION AS A FUNCTION OF SWITCHING FREQUENCY



Test Circuits and Waveforms (Continued)

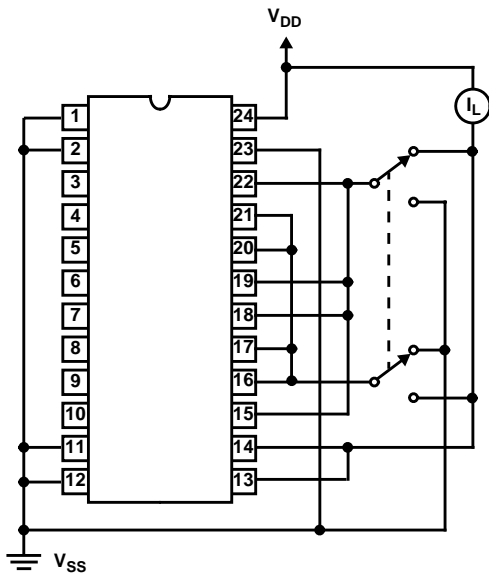
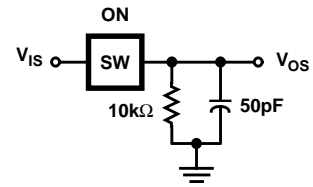

FIGURE 4. OFF SWITCH INPUT OR OUTPUT LEAKAGE CURRENT TEST CIRCUIT (16 OF 32 SWITCHES)



SW = ANY CROSSPOINT
STROBE = DATA - IN = V_{DD}

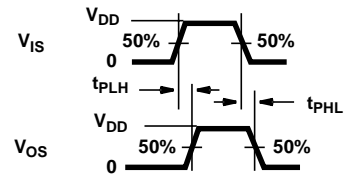
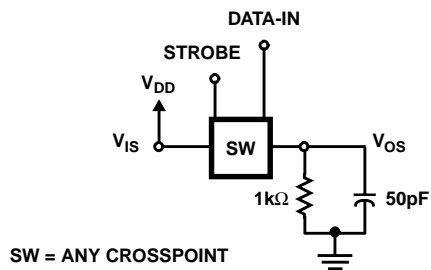

FIGURE 5. PROPAGATION DELAY TIME TEST CIRCUIT AND WAVEFORMS (SIGNAL INPUT TO SIGNAL OUTPUT, SWITCH ON)



SW = ANY CROSSPOINT

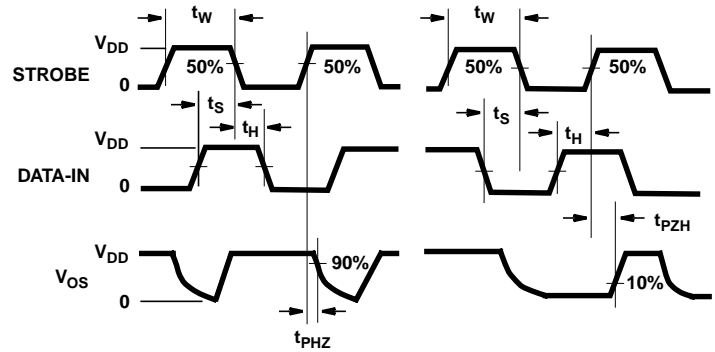

FIGURE 6. PROPAGATION DELAY TIME TEST CIRCUIT AND WAVEFORMS (STROBE TO SIGNAL OUTPUT, SWITCH TURN-ON OR TURN-OFF)

Test Circuits and Waveforms (Continued)

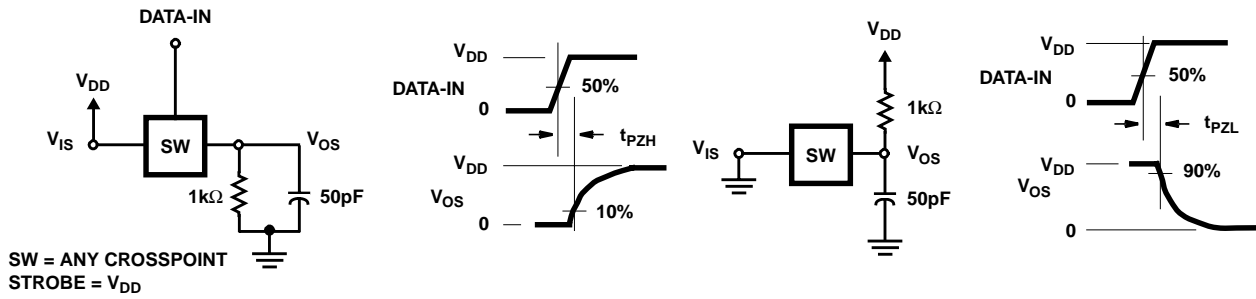

FIGURE 7. PROPAGATION DELAY TIME TEST CIRCUIT AND WAVEFORMS (DATA-IN TO SIGNAL OUTPUT, SWITCH TURN-ON TO HIGH OR LOW LEVEL)

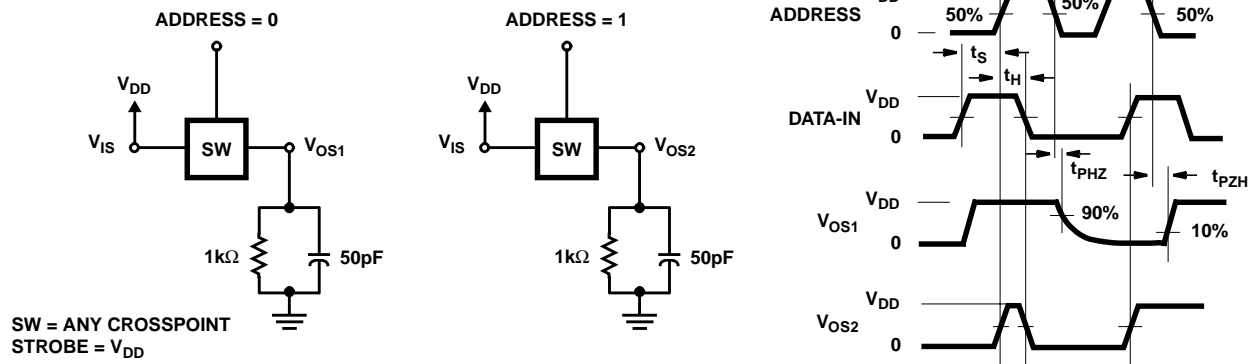
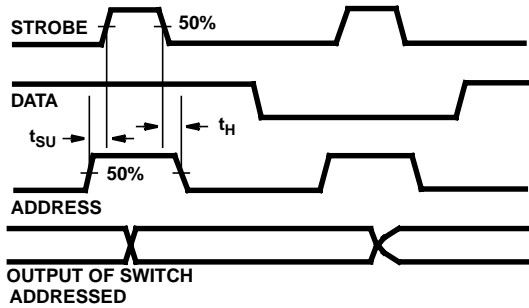
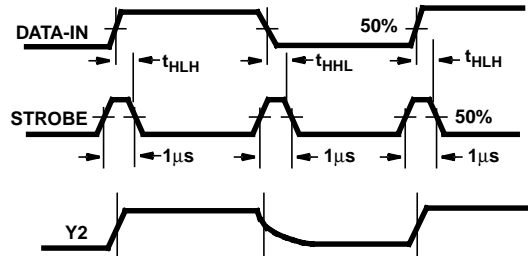

FIGURE 8. PROPAGATION DELAY TIME TEST CIRCUIT AND WAVEFORMS (ADDRESS TO SIGNAL OUTPUT, SWITCH TURN-ON OR TURN-OFF)

Test Circuits and Waveforms (Continued)



IF SETUP AND HOLD TIMES PROVIDED ARE TOO SHORT, AN UNADDRESSED SWITCH MAY BE TURNED ON OR OFF SIMULTANEOUSLY WITH THE ADDRESSED SWITCH



SET ALL SWITCHES TO OFF INITIALLY APPLY VDD TO ALL X INPUTS AND RETURN ALL Y OUTPUTS TO VSS THROUGH 1kΩ ADDRESS X1Y2 (ABCD) WITH $f_{IN} = 10\text{kHz}$

FIGURE 9. ADDRESS TO STROBE SETUP AND HOLD TIMES

FIGURE 10. STROBE TO DATA-IN HOLD TIME t_H , FOR CD22101

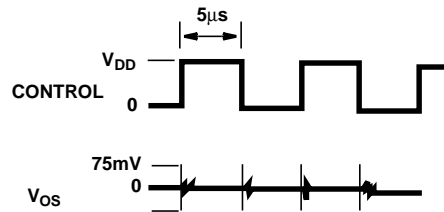
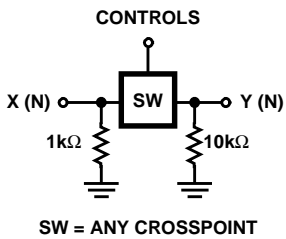

FIGURE 11. TEST CIRCUIT AND WAVEFORMS FOR CROSSTALK (CONTROL INPUT TO SIGNAL OUTPUT)

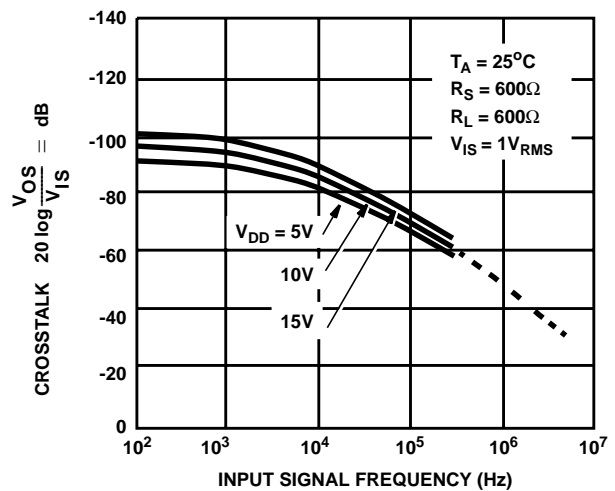
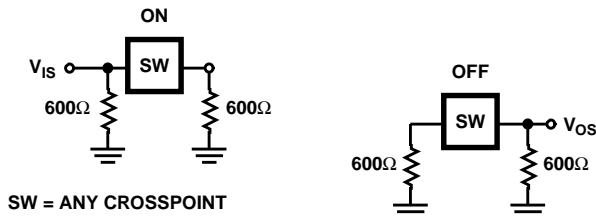

FIGURE 12. TEST CIRCUIT AND TYPICAL CROSSTALK AS A FUNCTION OF FREQUENCY BETWEEN SWITCH CIRCUITS IN THE SAME PACKAGE

Test Circuits and Waveforms (Continued)

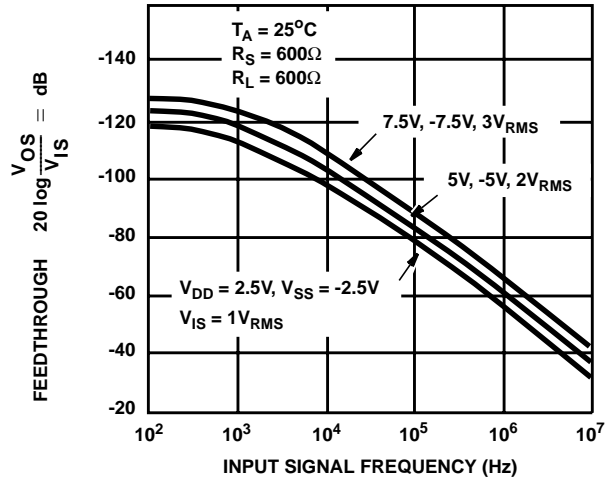
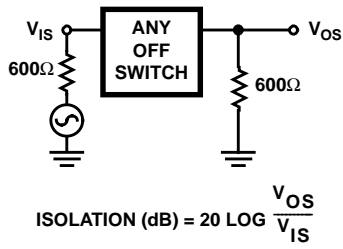

FIGURE 13. TEST CIRCUIT AND TYPICAL FEEDTHROUGH AS A FUNCTION OF FREQUENCY (ANY OFF SWITCH)

Typical Performance Curves

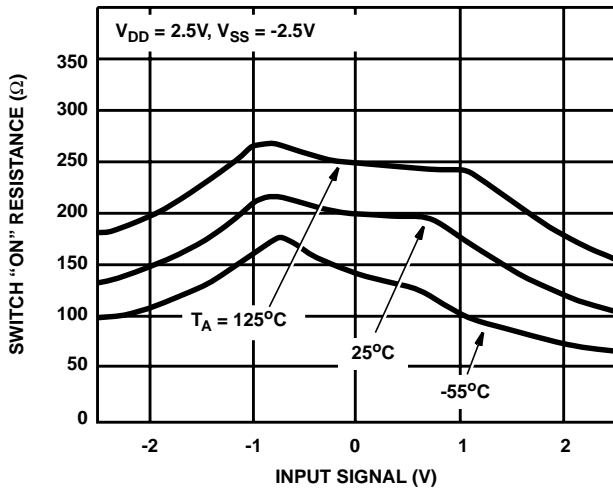

FIGURE 14. TYPICAL ON RESISTANCE AS A FUNCTION OF INPUT SIGNAL VOLTAGE AT $V_{DD} = -V_{SS} = 2.5V$

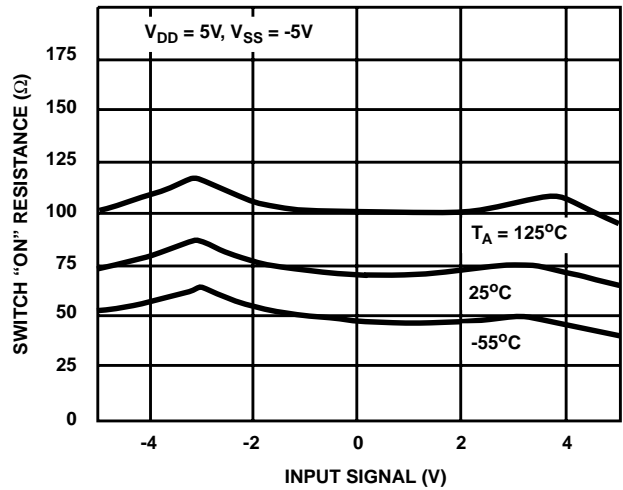

FIGURE 15. TYPICAL ON RESISTANCE AS A FUNCTION OF INPUT SIGNAL VOLTAGE AT $V_{DD} = -V_{SS} = 5V$

Typical Performance Curves (Continued)

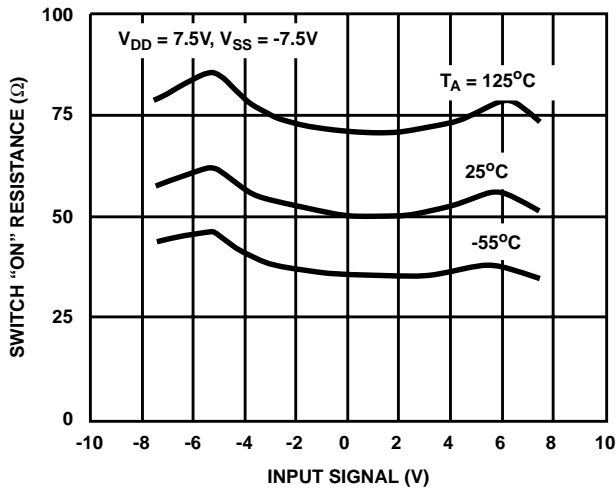

FIGURE 16. TYPICAL ON RESISTANCE AS A FUNCTION OF INPUT SIGNAL VOLTAGE AT $V_{DD} = -V_{SS} = 7.5V$

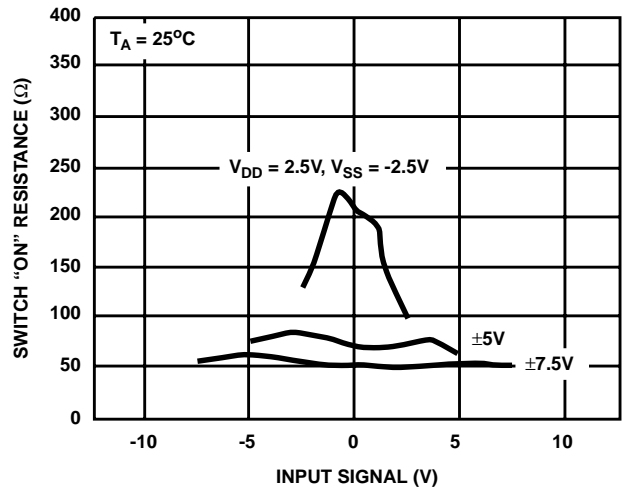

FIGURE 17. TYPICAL ON RESISTANCE AS A FUNCTION OF INPUT SIGNAL VOLTAGE AT $T_A = 25^\circ C$

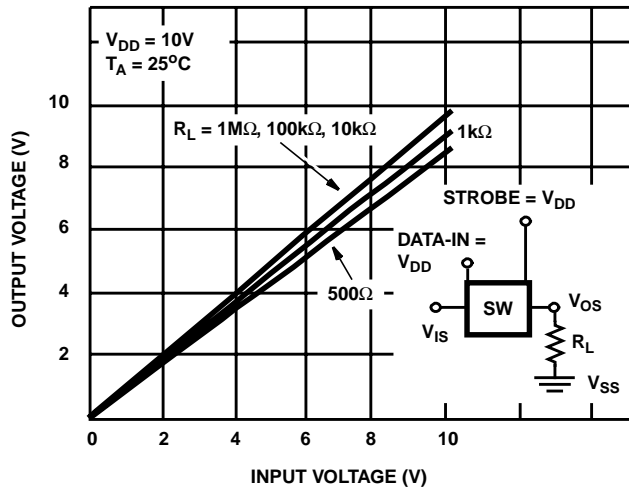

FIGURE 18. TYPICAL SWITCH ON TRANSFER CHARACTERISTICS (1 OF 16 SWITCHES)

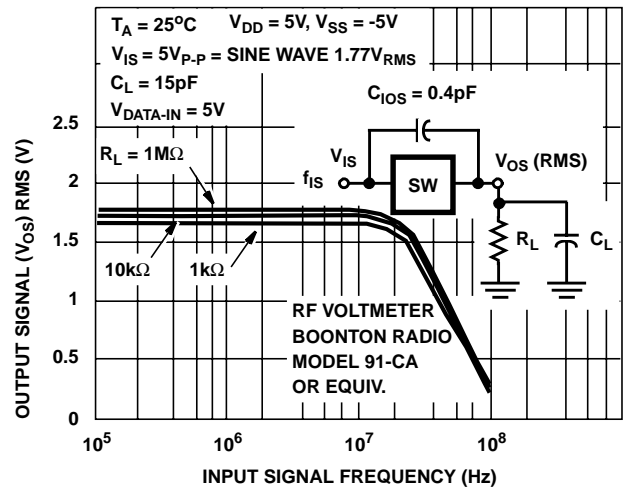

FIGURE 19. TYPICAL SWITCH ON FREQUENCY RESPONSE CHARACTERISTICS

This datasheet has been downloaded from:

www.DatasheetCatalog.com

Datasheets for electronic components.



LittleDiode supplies new, hard to find or obsolete electronic components and semiconductors all over the world.

With over two million different components listed you are sure to find the part you need.

Feel free to visit us today at our online store:

LittleDiode.com

Looking forward to providing you with the best possible service.