

**OBSOLETE PRODUCT
NO RECOMMENDED REPLACEMENT
Call Central Applications 1-800-442-7747
or email: centapp@harris.com**

Sync Generator for TV Applications and Video Processing Systems

May 1999

Features

- Interlaced Composite Sync Output
- Automatic Genlock Capability
- Crystal Oscillator Operation
- 525 or 625 Line Operation
- Vertical Reset Option
- Wide Power Supply Operating Voltage 4V to 15V

Applications

- Cameras
- Monitors and Displays
- CATV
- Teletext
- Video Games
- Sync Restorer
- Video Service Instruments

Part Number Information

PART NUMBER	TEMP. RANGE (°C)	PACKAGE	PKG. NO.
CD22402D	-55 to 125	24 Ld SBDIP	D24.6
CD22402E	-40 to 85	24 Ld PDIP	E24.6

Description

The Harris CD22402 (Note) is a CMOS LSI sync generator that produces all the timing signals required to drive a fully 2-to-1 interlaced 525-line 30-frame/second, or 625-line 25-frame/second TV camera or video processing system. A complete sync waveform is produced which begins each field with six serrated vertical sync pulses, preceded and followed by six half-width double frequency equalizing pulses. The sync output is gated by the master clock to preserve horizontal phase continuity during the vertical interval.

The CD22402 can be operated either in "genlock" mode, in which it is synchronized with a reference sync pulse train from another TV camera, or in "stand-alone" mode, in which it is synchronized with a local on-chip crystal oscillator (the crystal and two passive components are off chip). Also, the circuit can sense the presence or absence of a reference sync pulse train and automatically select the "genlock" or "stand-alone" mode.

A frame sync pulse is produced at the beginning of every odd field. The vertical counter can be reset to either the first equalizing pulse or the first vertical sync pulse of the vertical interval. The interlaced sync provided by the CD22402 differs from RS-170 by having slightly narrower sync and equalizing pulses. The clock frequency of 32 times horizontal rate allows for approximately 4 μ s horizontal pulse widths and 2 μ s equalizing pulses. Otherwise operation can be phase locked to a color sub-carrier for a full interlaced operating system.

The CD22402 is operable with a single supply over a voltage range of 4V to 15V.

Pinout

CD22402 (PDIP, SBDIP)
TOP VIEW

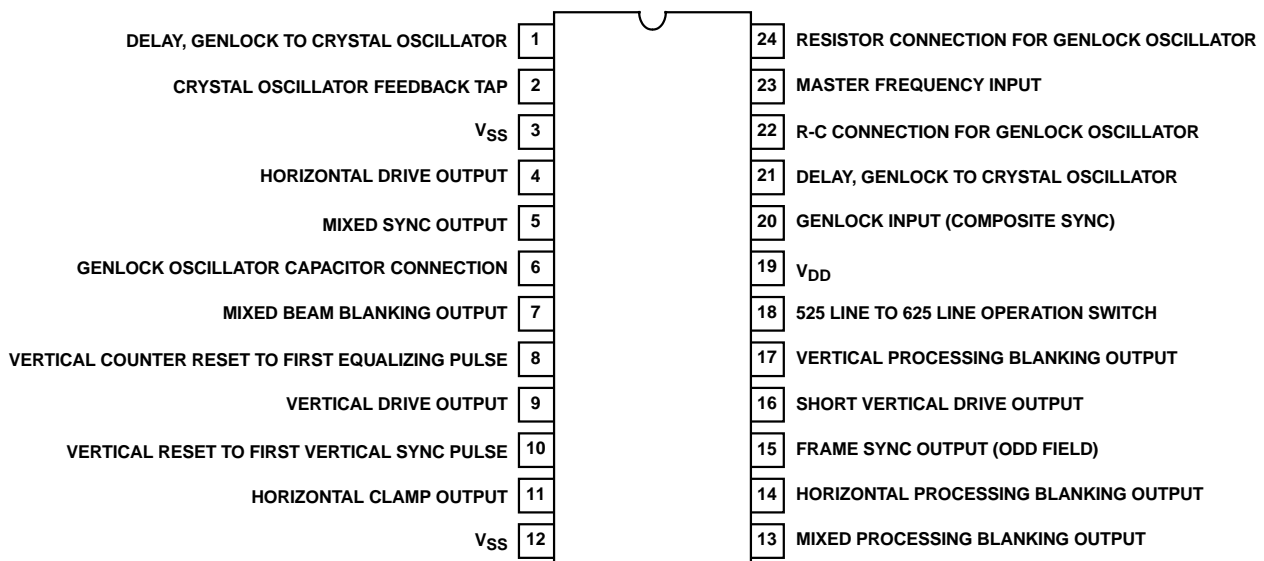

Pin Descriptions

PIN NO.	SYMBOL	DESCRIPTION
1	XRC	Delay, Genlock to Crystal Oscillator. Resistor, diode and capacitor connection for delay that automatically turns on the crystal oscillator when the genlock input is removed. When the signal on Terminal 1 is high the crystal oscillator is inhibited. Typical values for R and C are 1M Ω and 0.001 μ F. For operation as a crystal controlled stand alone sync generator without genlock, Terminal 1 should be hardwired to V _{SS} .
2	XTP	Crystal Oscillator Feedback Tap. Feedback connection (tap) for crystal oscillator. When a crystal (shunted by a 1M Ω resistor) is connected between this terminal and Terminal 23, and a 100pF capacitor is connected from this terminal to V _{SS} , the sync generator creates its own master frequency. For a 525-line, 30-frame/second raster, the crystal frequency is 504.000kHz (Note 1); and for a 625-line, 25-frame/second raster, the crystal frequency is 500.000kHz (Note 1).
3	V _{SS}	Negative Power Supply Voltage. This terminal must be hardwired to Terminal 12 (V _{SS}).
4	HD	Horizontal Drive Output
5	MS	Mixed Sync Output
6	C	Capacitor Connection for R-C Genlock Oscillator
7	MBB	Mixed Beam Blanking Output
8	VRE	Vertical Counter Reset to First Equalizing Pulse. A low level signal on this terminal resets the vertical counter to the first equalizing pulse of a field. When not in use this terminal should be connected to V _{DD} .
9	VD	Vertical Drive Output
10	VRV	Vertical Counter Reset to First Vertical Sync Pulse. A low level signal on this terminal resets the sync generator to the first vertical sync pulse of a field. For genlock operation, Terminal 10 is used as a resistor and capacitor connection for an integrator network that detects vertical sync pulses in a master sync waveform to which the sync generator is to be genlocked. R is 22k Ω , and C is 0.001 μ F. When not in use this terminal should be connected to V _{DD} .
11	HC	Horizontal Clamp Output
12	V _{SS}	Negative Power Supply Voltage
13	MPB	Mixed Processing Blanking Output
14	HPB	Horizontal Processing Blanking Output
15	FS2	Frame Sync Output (Odd Field). A pulse coinciding with the first equalizing pulse is produced at the beginning of every odd field.
16	SVD	Short Vertical Drive Output
17	VPB	Vertical Processing Blanking Output
18	SW	Operation Switch for 525-Line or 625-Line Raster. A high level signal on Terminal 18 causes the sync generator to generate a 625-line raster. An internal pulldown resistor is connected to Terminal 18, so in the absence of an applied input to this terminal, a 525-line raster is produced.
19	V _{DD}	Positive Power Supply Voltage. V _{DD} can be any voltage between +4 and +15 relative to V _{SS} .
20	GEN	Genlock Input Composite Sync. A negative going reference mixed sync waveform applied to Terminal 20 disables the crystal oscillator and locks the R-C genlock oscillator to the horizontal pulses of the reference sync waveform. Vertical sync detection is achieved by an R-C integrator connected from Terminal 20 to Terminal 10 (vertical reset to first vertical sync pulse). An internal pull-up resistor is connected to Terminal 20 so that in the absence of an applied input the crystal oscillator is enabled and the R-C genlock oscillator is disabled.
21	XR	Delay, Genlock to Crystal Oscillator, Resistor and Diode Connection for Delay, Genlock to Crystal Oscillator. Automatically turns on the crystal oscillator when the input to Terminal 20 is removed.
22	RC	Resistor and Capacitor Connection for Genlock Oscillator. If the genlock oscillator is not used this terminal should be connected to V _{SS} . C should be 100pF, and R should be a 10k Ω potentiometer.
23	XIN	Master Frequency Input.
24	R	Resistor Connection for Genlock Oscillator.

NOTE: 32 times horizontal frequency.

CD22402

Block Diagram

CD22402 MONOCHROME TV SYNC GENERATOR WITH AUTOMATIC GENLOCK

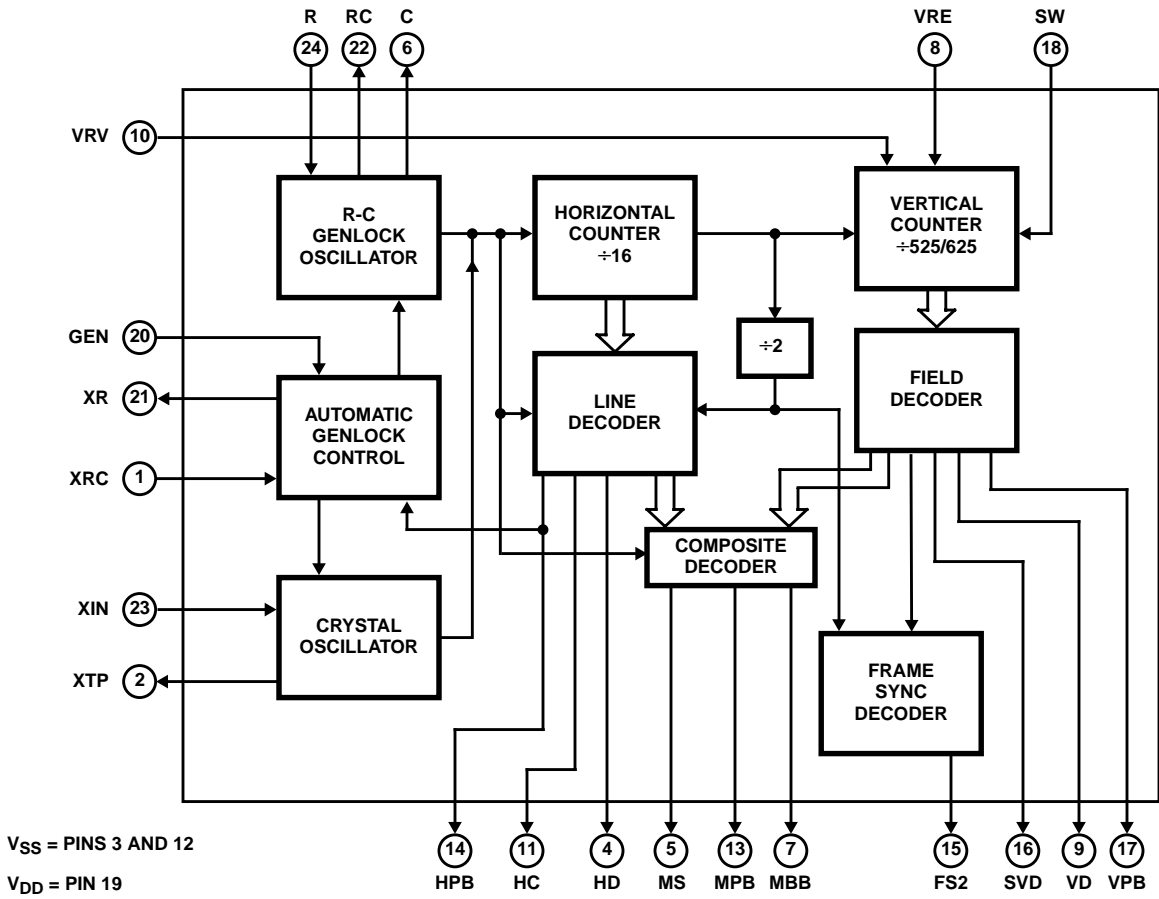

CD22402

Switching Electrical Specifications $T_A = 25^\circ\text{C}$ and $C_L = 15\text{pF}$. Typical Temperature Coefficient for All Values of $V_{DD} = 0.3\%/^\circ\text{C}$

PARAMETER (NOTE 4)	SYMBOL	TEST CONDITIONS	MIN	TYP	MAX	UNITS
		V_{DD} (V)				
Output State Propagation Delay Time (50% to 50%)						
Low-to-High Level	t_{PLH}	5	-	40	80	ns
High-to-Low Level	t_{PHL}	10	-	20	40	ns
Output State Transition Time (10% to 90%)						
Low-to-High	t_{TLH}	5	-	45	90	ns
High-to-Low	t_{THL}	10	-	30	60	ns
Input Capacitance (Per Input)	C_I	-	-	5	-	pF

NOTE:

- The characteristics given are defined for unbuffered gate in the CMOS process of the CD22402.

Logic Diagram

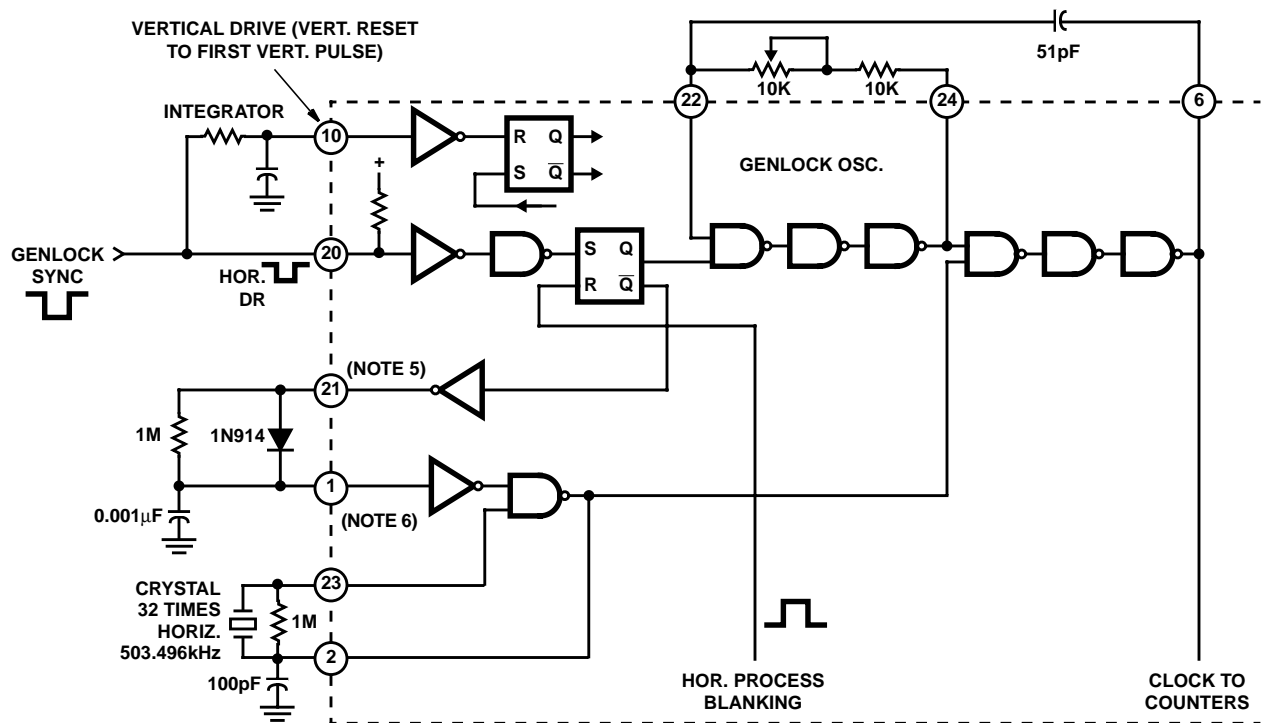

NOTES:

- Pin 21 high when pin 20 is high (or open).
- Pin 1 high inhibits clock.

FIGURE 1. DETAIL OF THE OSCILLATOR/GENLOCK PORTION OF THE CD22402

Timing Waveforms

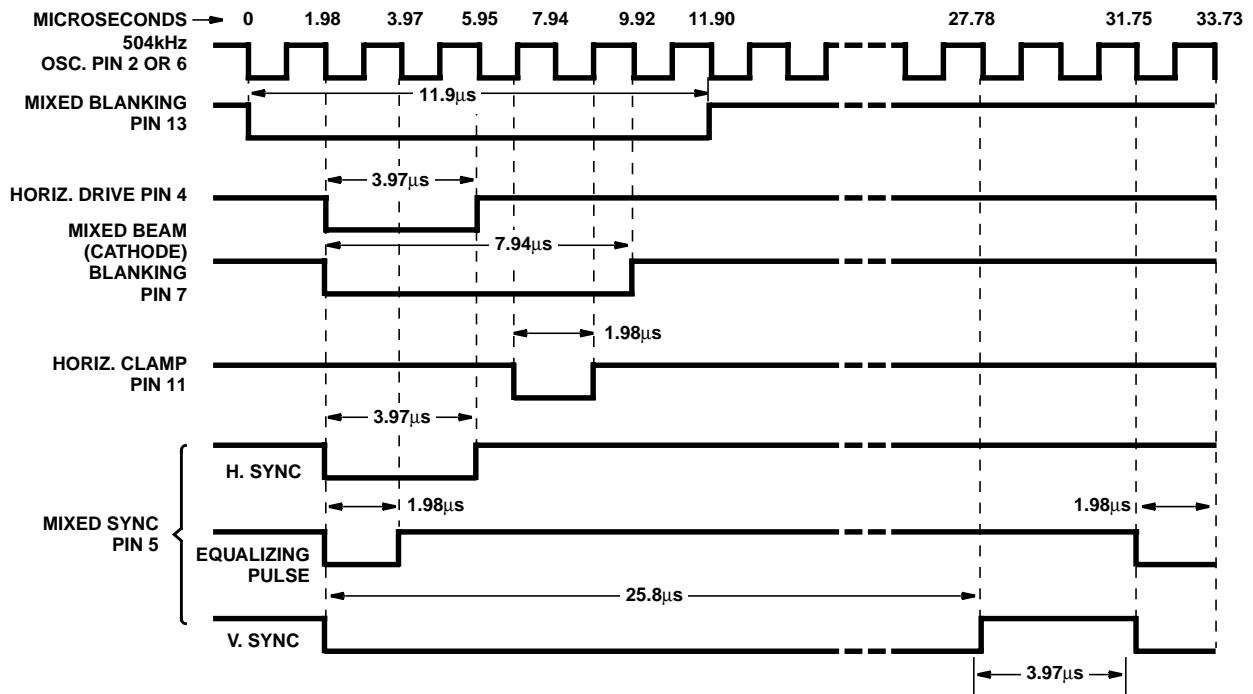

FIGURE 2. SYNC GENERATOR TIMING - 525/60Hz, HORIZONTAL TIMING WAVEFORMS

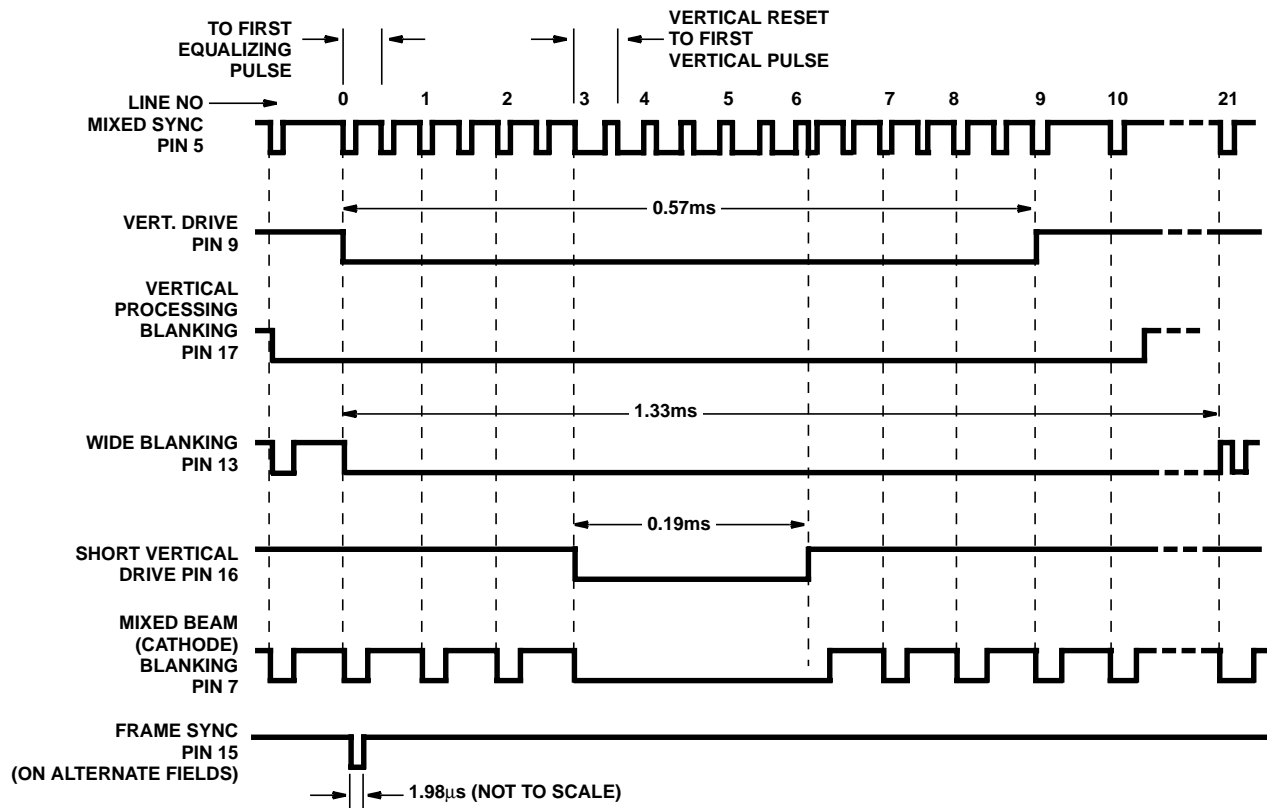

FIGURE 3. SYNC GENERATOR TIMING - 525/60Hz, VERTICAL TIMING WAVEFORMS

Timing Waveforms (Continued)

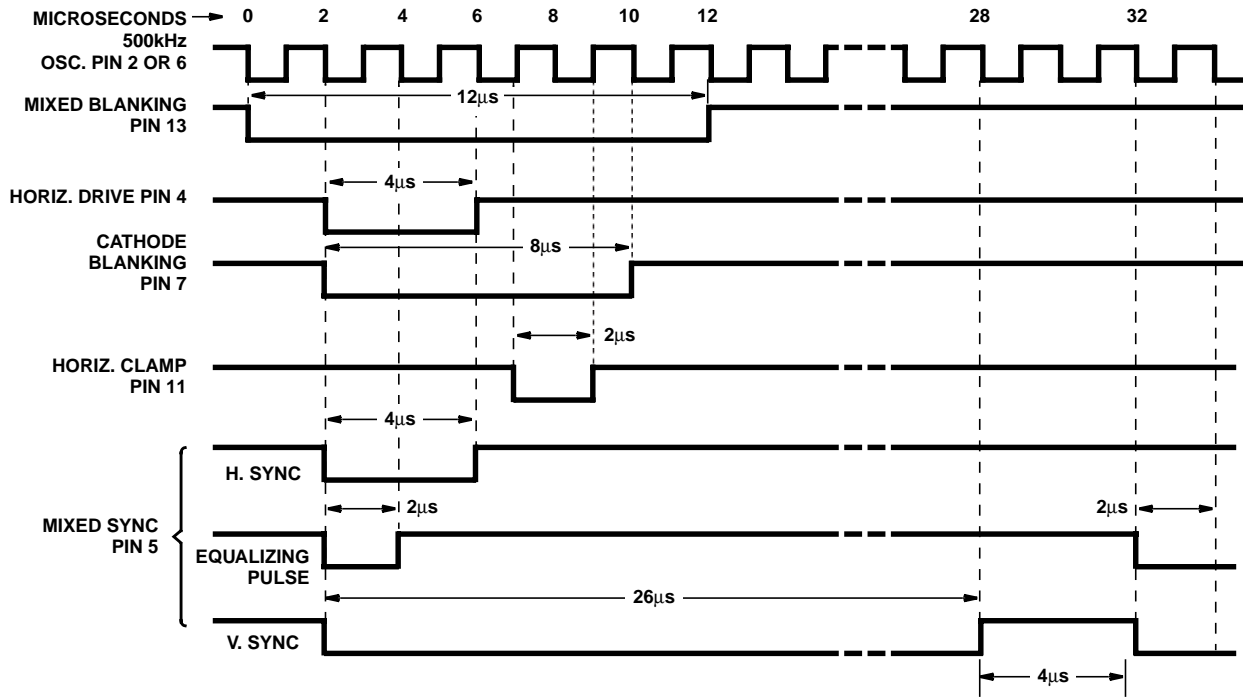

FIGURE 4. SYNC GENERATOR TIMING - 625/50Hz, HORIZONTAL TIMING WAVEFORMS

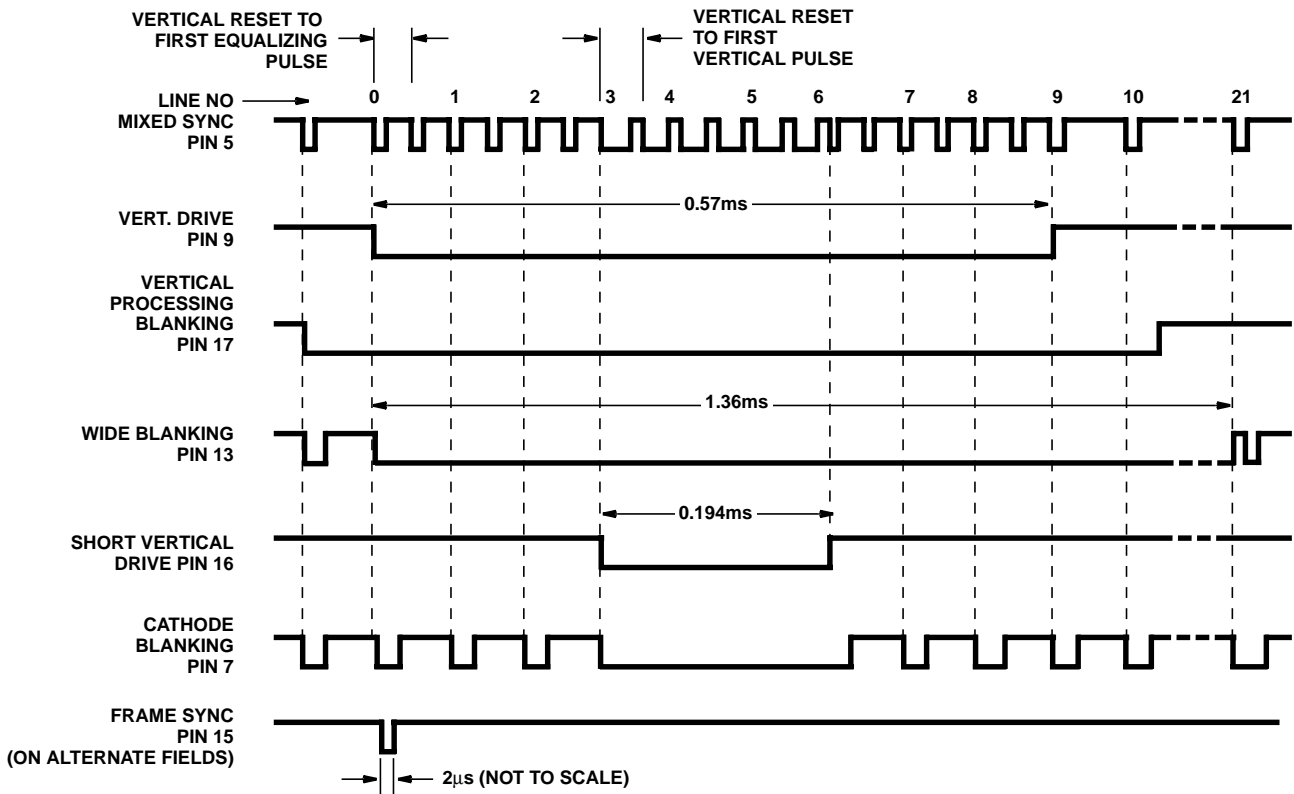

FIGURE 5. SYNC GENERATOR TIMING - 625/50Hz, VERTICAL TIMING WAVEFORMS

Timing Waveforms (Continued)

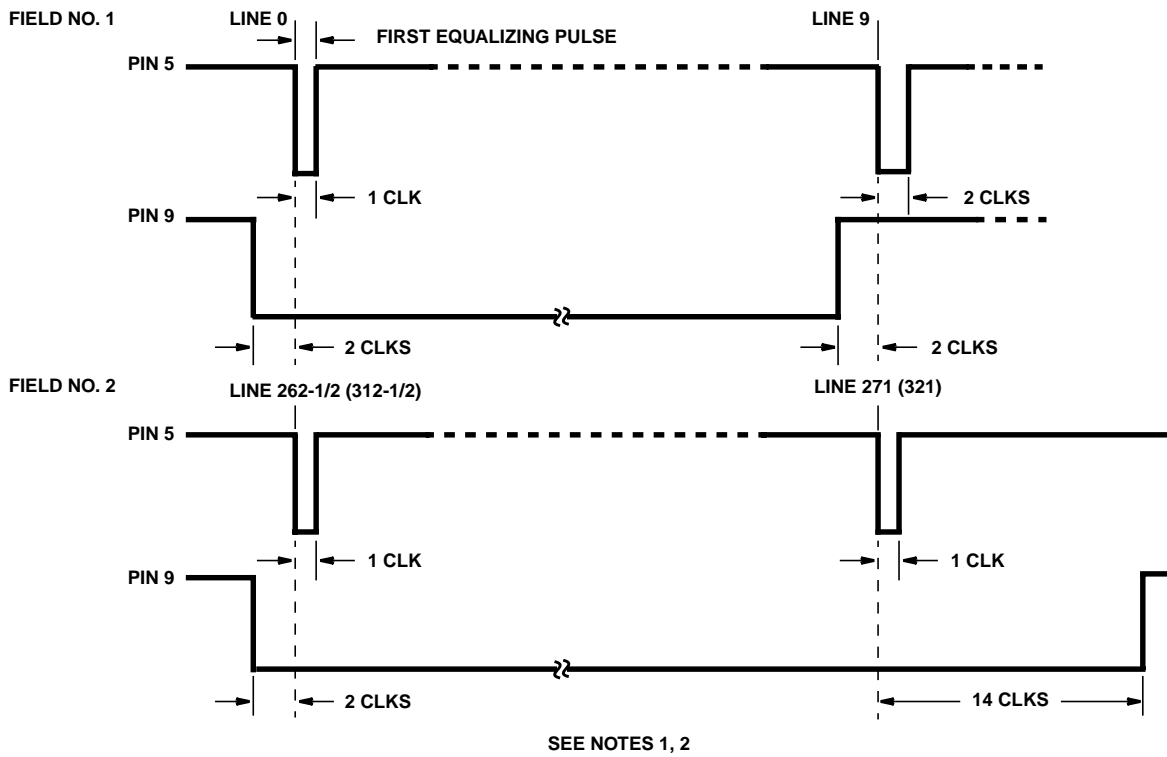

FIGURE 6. EXPANDED VERTICAL-TIMING WAVEFORM DETAIL OF SYNC GENERATOR TIMING (VERTICAL DRIVE - PIN 9)

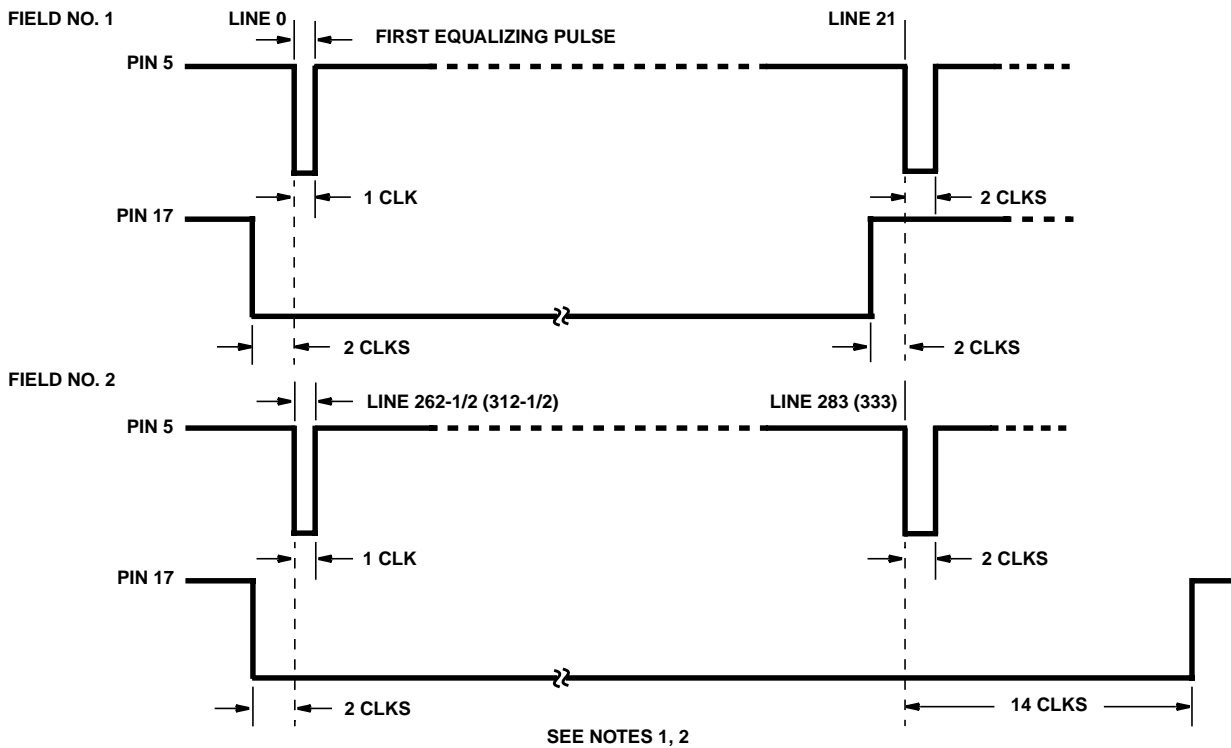

FIGURE 7. EXPANDED VERTICAL-TIMING WAVEFORM DETAIL OF SYNC GENERATOR TIMING (VERTICAL PROCESSING BLANKING - PIN 17)

Timing Waveforms (Continued)

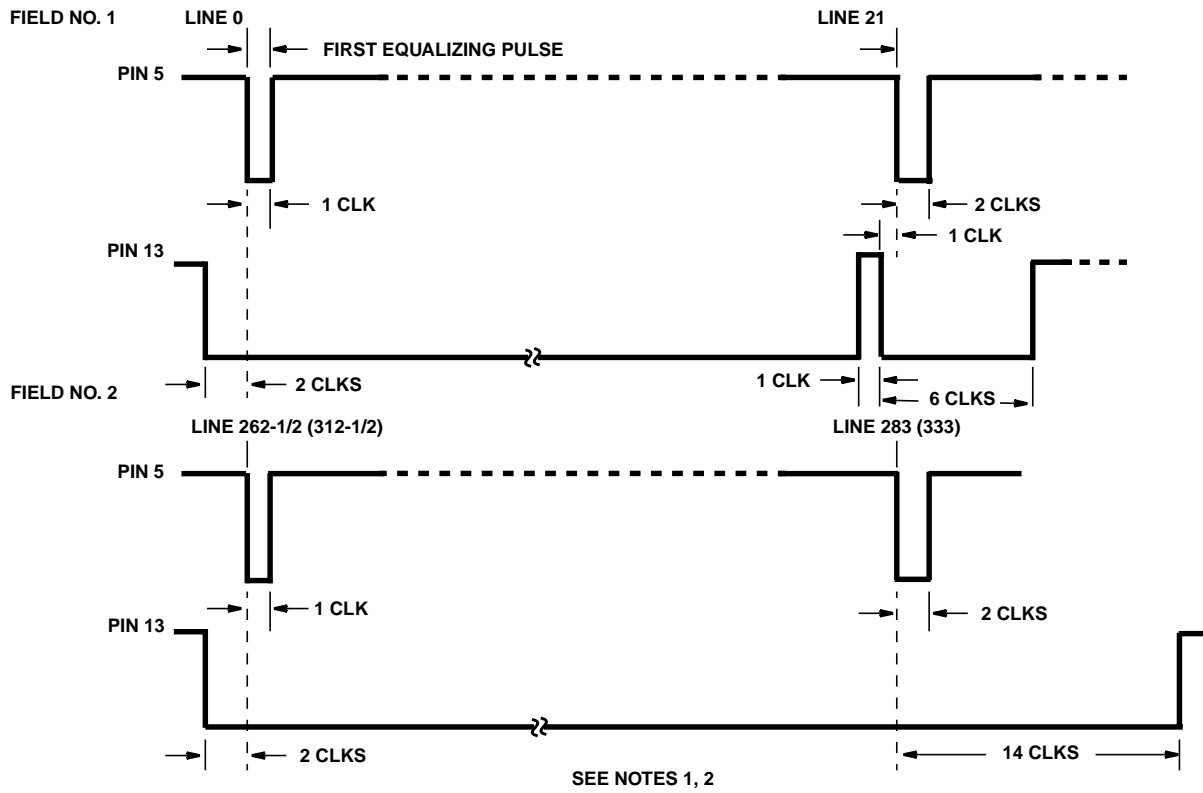

FIGURE 8. EXPANDED VERTICAL-TIMING WAVEFORM DETAIL OF SYNC GENERATOR TIMING (MIXED PROCESSING BLANKING - PIN 13)

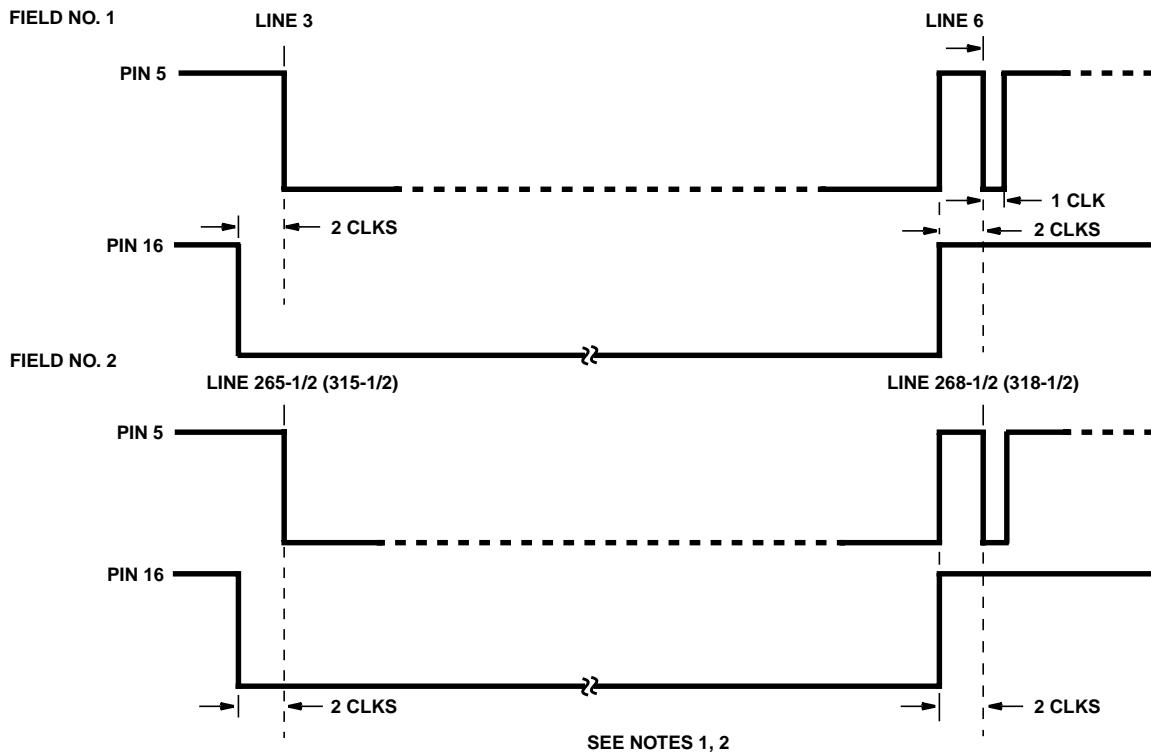
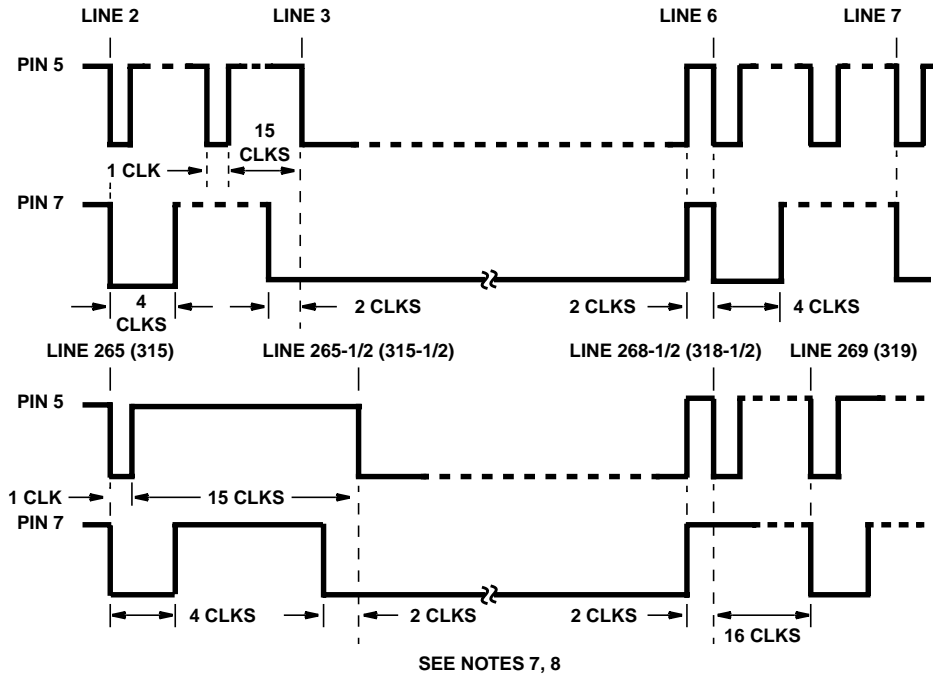

FIGURE 9. EXPANDED VERTICAL-TIMING WAVEFORM DETAIL OF SYNC GENERATOR TIMING (SHORT VERTICAL DRIVE - PIN 16)

Timing Waveforms (Continued)



SEE NOTES 7, 8

NOTES:

7. Waveforms shown are for 525 line/60Hz, line number in parenthesis are for (625 line/50Hz).
8. Timing widths by clock count; for 525 line, 1 CLK = 1.98μs; for 625 line, 1 CLK = 2μs; 1 horizontal period = 32 CLKS.

FIGURE 10. EXPANDED VERTICAL-TIMING WAVEFORM DETAIL OF SYNC GENERATOR TIMING (MIXED BEAM BLANKING - PIN 7)

Typical Applications (Refer to Application Note AN8742, for more information)

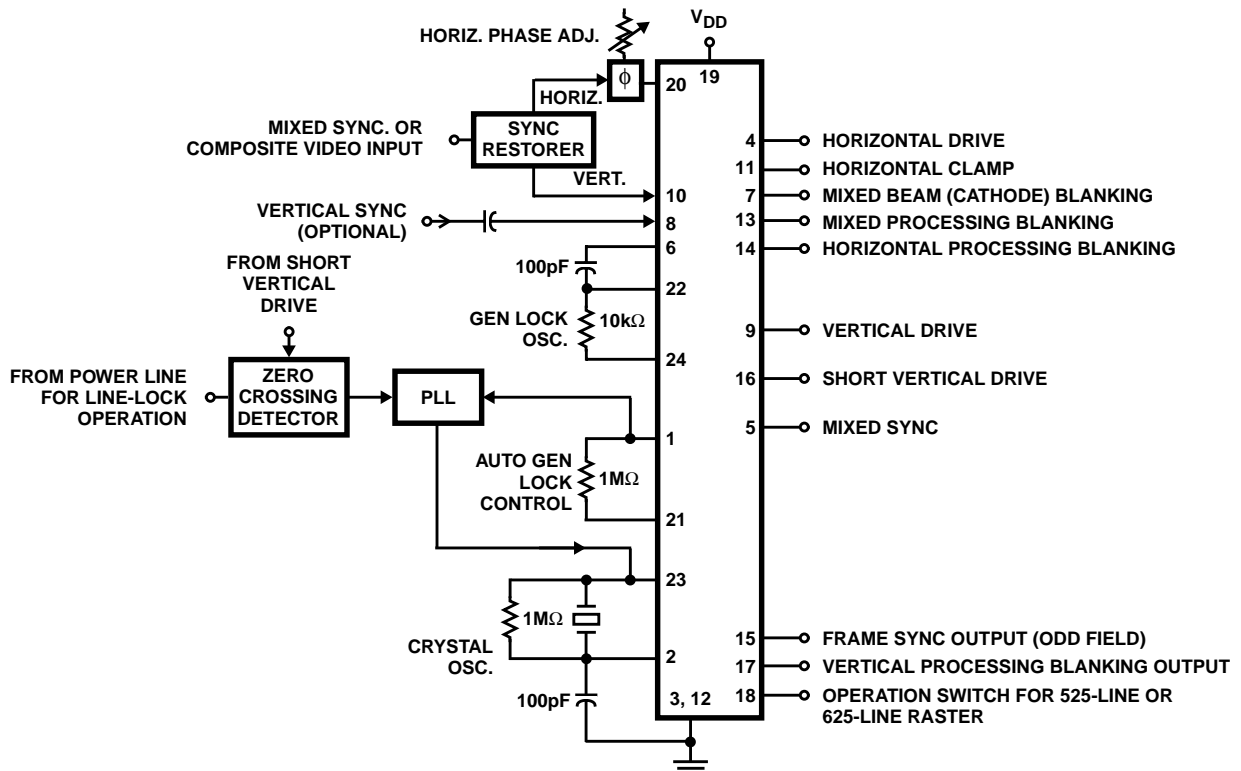
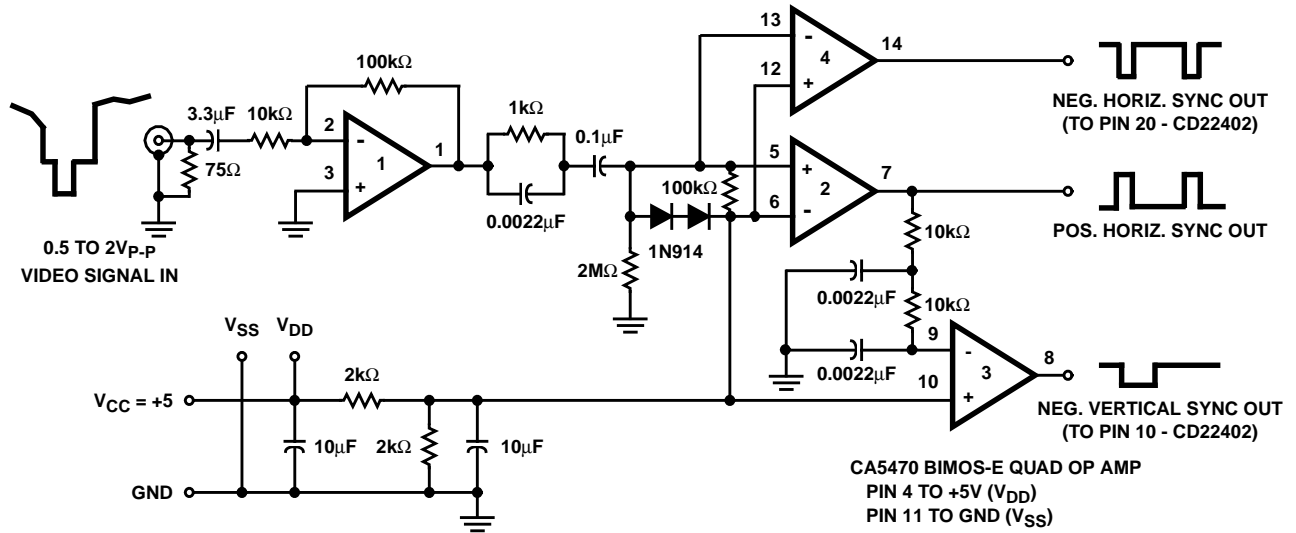

FIGURE 11. TYPICAL APPLICATION IN A TV CAMERA

CD22402



NOTE: The genlock input to pins 10 and 20 of the CD22402 are direct coupled to the output from Pins 8 and 14 of the CA5470. Refer to Application Note AN-8742 for additional information.

FIGURE 12. SUGGESTED SYNC-SEPARATOR CIRCUIT USING THE CA5470 BIMOS-E QUAD OP AMP IN THE V_{DD} RANGE OF 4V TO 12V

This datasheet has been downloaded from:

www.DatasheetCatalog.com

Datasheets for electronic components.



LittleDiode supplies new, hard to find or obsolete electronic components and semiconductors all over the world.

With over two million different components listed you are sure to find the part you need.

Feel free to visit us today at our online store:

LittleDiode.com

Looking forward to providing you with the best possible service.