

April 1994

Serial Multiplexed Bus Interface

Features

- Differential Bus for Minimal EMI
- High Common Mode Noise Rejection
- Ideal for Twisted Pair Wiring
- Data Collision Detection
- Bus Arbitration
- Idle Detection
- Programmable Clock Divider
- Power-On Reset

Description

The CDP68HC68S1 Serial Bus Interface Chip (SBIC) provides a means of interfacing in a Small Area Network configuration, various microcomputers (MCU's) containing serial ports. Such MCU's include the family of 68HC05 microcontrollers. The SBIC provides a connection from an MCU's Serial Communication Interface (asynchronous UART type interface) or Serial Peripheral Interface (synchronous) to a medium speed asynchronous two wire differential signal bus designed to minimize electromagnetic interference. This two wire bus forms the network bus to which all MCU's are connected (through SBI chips). See Figure 1. Each MCU operates independently and may be added or deleted from the bus with little or no impact on bus operation. Such a bus is ideal for inter-microcomputer communication in hazardous electrical environments such as automobiles, aircraft or industrial control systems.

Ordering Information

PART NUMBER	TEMPERATURE RANGE	PACKAGE
CDP68HC68S1E	-40°C to +105°C	14 Lead PDIP
CDP68HC68S1M	-40°C to +105°C	20 Lead SOIC (W)

In addition to acting as bus arbitor and interface for microcomputer SCI port to differential bus communication, the CDP68HC68S1 contains all the circuitry required to convert and synchronize Non-Return-to-Zero (NRZ) 8-bit data received on the differential bus and clock the data into a microcomputer's SPI port. Likewise, data to be sent by a microcomputer's SPI port is converted to asynchronous format by appending start and stop bits before transmitting to other microcomputers.

Refer to the data sheet for the CDP68HCO5C4 for additional information regarding CDP68HCO5 microcomputers and their Serial Communications and Serial Peripheral Interfaces.

The CDP68HC68S1 is supplied in a 14 lead dual-in-line plastic package (E suffix), and in a 20 lead small outline plastic package (M suffix).

Operating voltage ranges from 4V to 7V and operating temperature ranges from -40°C to +105°C.

Pinouts

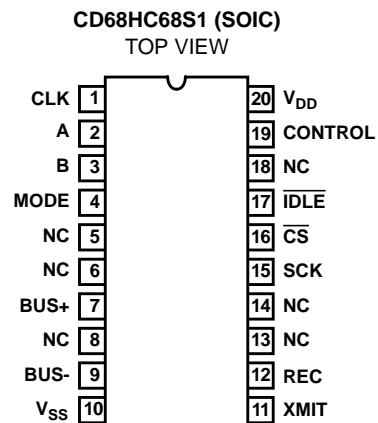
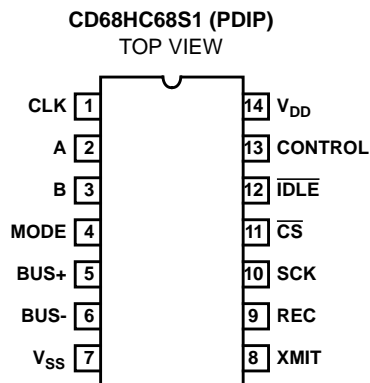

Block Diagram

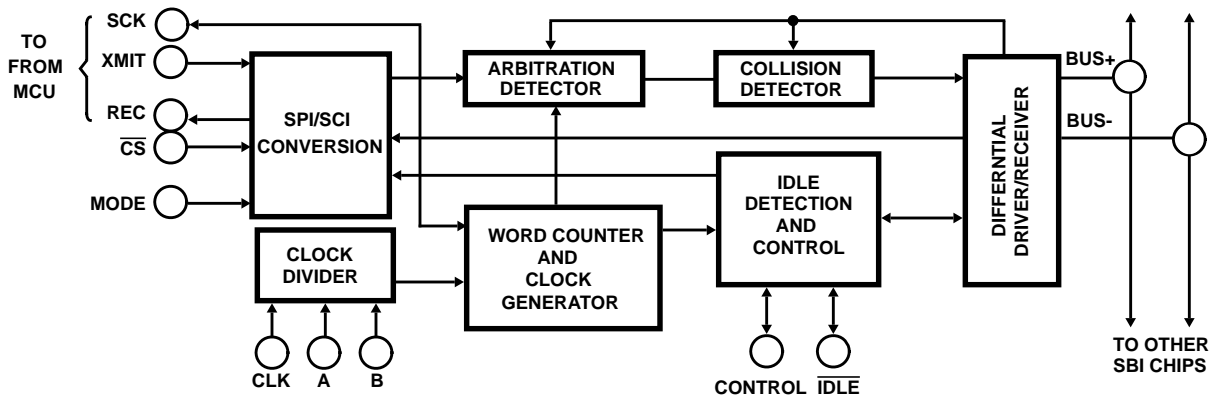

Specifications CDP68HC68S1

Absolute Maximum Ratings

Supply Voltage (V_{DD}) -0.3V to +7.0V
 Input Voltage (V_{IN}) V_{SS} -0.3V to $V_{DD}+0.3V_{DC}$
 DC Input Current (I_{IN}) $\pm 10\text{mA}$

Thermal Information

Thermal Resistance θ_{JA}
 Plastic DIP Package $100^{\circ}\text{C}/\text{W}$
 Plastic SOIC Package $120^{\circ}\text{C}/\text{W}$
 Storage Temperature Range (T_{STG}) -55°C to $+125^{\circ}\text{C}$
 Lead Temperature (Soldering 10s) $+265^{\circ}\text{C}$

CAUTION: Stresses above those listed in "Absolute Maximum Ratings" may cause permanent damage to the device. This is a stress only rating and operation of the device at these or any other conditions above those indicated in the operational sections of this specification is not implied.

Operating Conditions

Operating Temperature (T_A) -40°C to $+105^{\circ}\text{C}$ DC Operating Voltage Range (V_{DD}) $+4\text{V}$ to $+7\text{V}$

DC Electrical Specifications

$T_A = -40^{\circ}\text{C}$ to $+105^{\circ}\text{C}$ Unless Otherwise Noted. External Bias (V_O) shall be 1.8V to 3.13V Unless Otherwise Noted.

PARAMETERS	SYMBOLS	TEST CONDITIONS	MIN	MAX	UNITS
SIGNAL I/O SECTION					
Output Voltage High Level	V_{OL}	Open Circuit	-	0.05	V_{DC}
Output Voltage Low Level	V_{OH}	Open Circuit	$V_{DD}-0.05$	-	V_{DC}
Input Voltage Low Level	V_{IL}		-	$0.3V_{DD}$	V_{DC}
Input Voltage High Level	V_{IH}		$0.7V_{DD}$	-	V_{DC}
Output High Drive (Source) Current (REC Pin)	I_{OH}	$V_{OH} = 4.6\text{V}, V_{DD} = 5\text{V}$	-0.12	-	mA
Output High Drive (Source) Current (IDLE, Control Pins)	I_{OH}	$V_{OH} = 4.6\text{V}, V_{DD} = 5\text{V}$	-0.04	-	mA
Output Low Drive (Sink) Current (IDLE, Control, REC)	I_{OL}	$V_{OH} = 0.4\text{V}, V_{DD} = 5\text{V}$	0.36	-	mA
DIFFERENTIAL TRANSCIEVER (SEE FIGURE 4) TRANSMITTER					
BUS+	I_{AOL}	$V_O = V_{DD}/2, R_L = 120\Omega$	2.75	-	mA
	I_{AOH}	$V_O = V_{DD}/2, R_L = 120\Omega$	-1.0	1.0	μA
BUS-	I_{BOL}	$V_O = V_{DD}/2, R_L = 120\Omega$	-	-2.75	mA
	I_{BOH}	$V_O = V_{DD}/2, R_L = 120\Omega$	-1.0	1.0	μA
$I_{AOL} - I_{BOL}$ Match	I_M	$V_O = V_{DD}/2, R_L = 120\Omega,$ $V_{DD} = 5\text{V} \pm 0.5\text{V}$	-	5	%
Output Rise Time (BUS+)	t_R	$V_{DD} = 5\text{V}, C_L = 25\text{pF}$	-	1.5	μs
Output Fall Time (BUS-)	t_F	$V_{DD} = 5\text{V}, C_L = 25\text{pF}$	-	1.5	μs
Transition match (50% Point)	t_M	$V_{DD} = 5\text{V}, C_L = 25\text{pF}$	-50	50	ns
RECEIVER					
Differential Sensitivity	V_{IDH}	$V_O = 2.5\text{V}, R_L = 120\Omega, V_{DD} = 5\text{V}$	-	120	mV
	V_{IDL}	$V_O = 2.5\text{V}, R_L = 120\Omega, V_{DD} = 5\text{V}$	20	-	mV
Hysteresis (Within V_{IDH}, V_{IDL} Limits)	V_H	$V_O = 2.5\text{V}, R_L = 120\Omega, V_{DD} = 5\text{V}$	20	-	mV
Propagation Delay	t_P	$V_{IDH} = 120\text{mV}, V_{DD} = 5\text{V}$	-	700	ns
Out of Range	V_{AX}	$V_{DD} = 5\text{V}$	3.8	-	V
	V_{MIN}	$V_{DD} = 5\text{V}$	-	1.2	V
Quiescent Device Current	I_{DD}	$V_{DD} = 0\text{V}, V_O = 2.5\text{V}$	-10	10	μA
Clock Speed	f_{OP}	$V_{DD} = 5, R_L = 120\Omega, C_L = 25\text{pF}$	-	TBD (Note)	MHz

NOTE: Although 1MHz is generally used as an example throughout this datasheet, the maximum speed limit may be higher and depends upon user's noise tolerance requirements.

The Serial Bus IC offers the user three possible modes of operation as defined by Table 1 - SCI (Note 1), SPI, and Buffered SPI. Also included is a "three-state mode" entered by pulling the CS pin high while in the Buffered SPI mode. As the name implies, the SCI mode is used when communicating through the microcomputer's SCI port. In this mode, asynchronous NRZ data format (1 start bit, 8 data bits 'least significant bit first', and 1 stop bit) and baud rate remain the same on each "side" of the SBIC, i.e. to and from the micro and to and from the differential network bus.

TABLE 1. MODE AND CHIP SELECT DEFINITION

SBI CHIP MODE	MODE PIN	CS PIN
SCI	1	1
SPI	1	0
Buffered SPI	0	0
Three-State (Note 2)	0	1

NOTES:

1. SCI is the UART interface of a 68HC05 MCU. The CDP68HC68S1 is compatible with most UART devices.
2. The three-state mode is only entered when using the Buffered SPI mode. In the three-state mode, only the XMIT, REC, and SCK pins are three-stated. The CONTROL and IDLE pins are always active.

During data transmission, while a byte is being transmitted from the MCU through the SBI chip onto the differential bus, it is also reflected and simultaneously received back at the micro, (this is required for bus arbitration as described later).

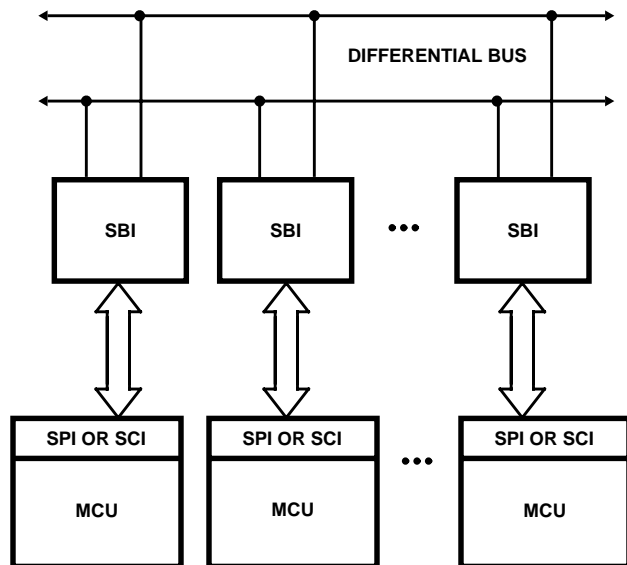

FIGURE 1. POSSIBLE NETWORK CONFIGURATION-VARIOUS MICROCOMPUTERS USING SBI CHIPS TO COMMUNICATE ALONG DIFFERENTIAL BUS.

In addition to performing a framing error check in the SCI mode, other advantages gained by using the SBIC (in any mode) include greater system EMI tolerance and automatic

bus "monitoring". The Serial BUS Interface chip handles bus arbitration, data collision detection, and provides short circuit protection.

A 68HC05 MCU's SPI port may instead be used for bus communication. Two modes of SPI operation are available with the SBIC - one essentially places the 68HC05 microcomputer in the slave mode and the other allows the MCU to remain a master. In the normal SPI mode the SBIC acts as a master and supplies a data-synchronizing serial clock signal to the micro (which operates in the slave mode) for shifting data in or out of the micro's 8-bit SPI data register. Again, baud rates are the same on each side of the SBIC, however, the user must reverse the bit order of a byte transmitted or received via the SPI port due to the SPI's most significant bit first serial data nature. In addition, since the user microcomputer is operating in the slave mode it must signal the SBI chip (by pulling the CONTROL line low) to initiate a transmission. As in the SCI mode, during a transmission, the byte originally in the SPI data register is replaced by the byte reflected from the bus.

Transmission and reception of data in the Buffered SPI mode allows the user to free the micro's SPI port by allowing fast data communication (1M bits/second) between the SPI port and SBIC. For instance, if the MCU is transmitting, the SBIC converts the data stream from the MCU's SPI port to a slower speed for transmission along the differential bus when the bus becomes idle. Data speed conversion is accomplished via a 2 byte (16-bit) data buffer register residing in the serial bus chip. In this mode the MCU operates as a master and provides the serial clock signal to the slave SBIC peripheral. After fast data has been sent to or received from the SBIC, the micro can pull the SBIC's CS pin high (placing the SBIC chip in the three-state mode) and then use the SPI port to access other SPI peripherals.

All transfers between the user MCU and the SBIC in the Buffered SPI mode consist of 2 bytes, i.e. a message consists an even number of 8-bit transfers. A microcomputer wishing to transmit loads 2 bytes into the serial bus IC data register and then pulls the control pin low to initiate transmission. During transmission the 2 bytes placed into the buffer are replaced by the two reflected bytes received from the bus. After every 2 byte transmission the user micro should transfer the two reflected bytes out of the buffer and the next 2 bytes to be transmitted into the buffer.

TABLE 2. CLOCK PROGRAMMING

CLOCK INPUT DIVIDE FACTOR	A PIN	B PIN
÷ 1	0	0
÷ 2	0	1
÷ 4	1	0
÷ 10	1	1

CDP68HC68S1

Functional Pin Description

PIN NUMBER	SYMBOL	IN/OUT	DESCRIPTION
1	CLK	Input	This is the clock input that shall be divided by the SBIC (as described in Table 2) and used as an internal synchronizing clock. The internal clock is then further divided by 128 to determine baud rate, i.e. 128 internal clock periods constitute 1-bit length.
2, 3	A and B	Input	Programming inputs of the clock divider. These inputs are tied to +V _{DD} or V _{SS} depending upon speed of external clock source. (See Table 2)
4	Mode	Input	This input shall be used in conjunction with \overline{CS} input to define the mode of operation (see Table 1). It may be permanently wired to +V _{DD} or V _{SS} or driven high or low by MCU I/O lines.
5, 6	BUS+ and BUS-	Input/Output	This is the two wire differential bus I/O used to transmit and receive data to and from the differential bus. BUS+ is both responsive to, or driven positive by sourcing current from an externally established bias point. This sourcing current matches the BUS- I/Os sinking current. BUS- is both responsive to, or driven negative by sinking current from an externally established bias point. This sinking current matches the BUS+ I/Os sourcing current.
14, 7	V _{DD} and V _{SS}	-	Power and ground reference are supplied to the device via these pins. V _{DD} is power and V _{SS} is ground.
8	XMIT	Input	In the SCI mode this data input shall come from the microcomputer standard NRZ asynchronous communications output port (68HC05 SCI port pin TxD). In the SPI modes, it shall come from the microcomputer's synchronous output port (68HC05 SPI port pin MOSI or MISO).
9	REC	Output	In the SCI mode this data output shall be fed into the microcomputer asynchronous communications input port (68HC05 SCI port pin RxD). In the SPI modes it shall be fed into the microcomputer's synchronous input port (6805 SP1 port pin MOSI or MISO).
10	SCK	Input/Output	In the SCI mode, this I/O is not required. In both SPI modes this pin is connected to the 68HC05's SPI port SCK pin. In the normal SPI mode, the SBIC shall produce shift clock pulses via this pin for synchronously shifting data into and out of the microcomputer. In the Buffered SPI mode this pin is an input and the microcomputer shall generate the shift clock pulses. Figure 3 shows the relationship between the serial clock signal and other SBIC signals in the SPI mode.
11	\overline{CS}	Input	This input shall be used in conjunction with the mode input and shall be used as a chip select (see Table 1). It may be permanently wired to +V _{DD} or V _{SS} or driven high or low by MCU I/O lines.
12	\overline{IDLE}	Input/Output	The microcomputer shall monitor this signal to determine the bus condition and also pull this line low to generate a break. The \overline{IDLE} signal goes low when the bus is idle (after sensing an End of Message condition) and high when the bus is active. On reset, this pin is set to a logic zero.
13	Control	Input/Output	The microcomputer shall monitor this I/O pin in the SPI mode to handle transmission and reception of data. In the SCI and SPI modes, as an output, this pin will go low to indicate that a data byte is currently active on the bus. In the Buffered SPI mode the control pin indicates whether the user microcomputer has current access to the SBI chip's internal 2 byte buffer (signified by a logic high on the control pin). In both SPI modes the control pin is also effective as an input. In these modes the control pin is pulled low by the user microcomputer to initiate a transmit operation by the SBIC. The control pin is normally high when the bus is inactive. On reset, this pin is set to a logic high.

All Intersil semiconductor products are manufactured, assembled and tested under **ISO9000** quality systems certification.

Intersil products are sold by description only. Intersil Corporation reserves the right to make changes in circuit design and/or specifications at any time without notice. Accordingly, the reader is cautioned to verify that data sheets are current before placing orders. Information furnished by Intersil is believed to be accurate and reliable. However, no responsibility is assumed by Intersil or its subsidiaries for its use; nor for any infringements of patents or other rights of third parties which may result from its use. No license is granted by implication or otherwise under any patent or patent rights of Intersil or its subsidiaries.

For information regarding Intersil Corporation and its products, see web site <http://www.intersil.com>

Differential Transceiver Cell

The differential transceiver is a serial interface device which accepts digital signals and translates this information for transmitting on the two wire differential bus.

The transmitter section (shown in Figure 4), when transmitting, provides matched constant current sources to the bus “+” and bus “-” I/O sourcing and sinking respectively. When transmitting, a logic zero at the “transmit data” input causes the bus “+” I/O to provide source current and the bus “-” I/O to provide a matched sink current. A logic one at the “transmit data” input causes the bus “+” and bus “-” I/Os to simultaneously provide a high impedance state. The bus depends on external resistor components for bias and termination. Recommended resistor sizes are shown in Figure 4.

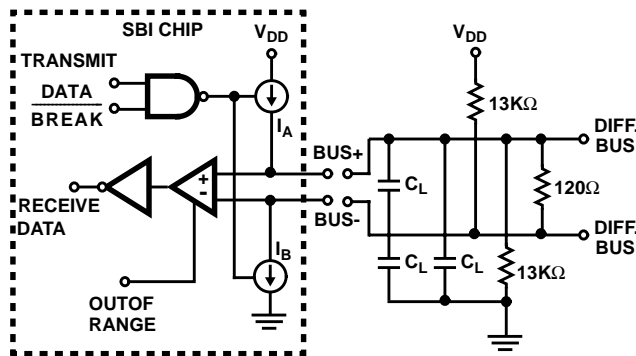

FIGURE 4. DIFFERENTIAL DRIVER/RECEIVER

A zero transmitted on the bus will appear as a large voltage drop across the BUS+ and BUS- pins, i.e. BUS+ might typically sit at +2.8V and BUS- at +2.2V for a logic zero. For a logic level one, the SBIC actually three-states the BUS+ and BUS- pins and relies on external resistors to bias the bus lines. The lines are both biased to sit at approximately 2.5V with a small (perhaps 20mV) voltage drop across the two lines. In this condition the BUS- line actually sits at a slightly higher potential than the BUS+ line. See Figure 5. Thus, the

bus actually “floats” to a logic level one, but must be driven to a logic level zero. Logic 0-bits always dominate over logic 1-bits on the bus. If two MCU’s simultaneously transmit a zero and a one on the bus, the zero will override the one and the bus will merely appear to be transmitting a zero. The “marking” or idle signal on the bus is a logic one. If the bus is idle or if a micro is sending a logic one, then a one will appear on the bus.

In addition to the transmission of data, the differential data transceiver accepts at its bus “+” and bus “-” I/Os, serial differential data which is translated into the standard digital logic levels. This reception of data also occurs while transmitting, thus reflecting the data seen on the bus back into the SBIC data register.

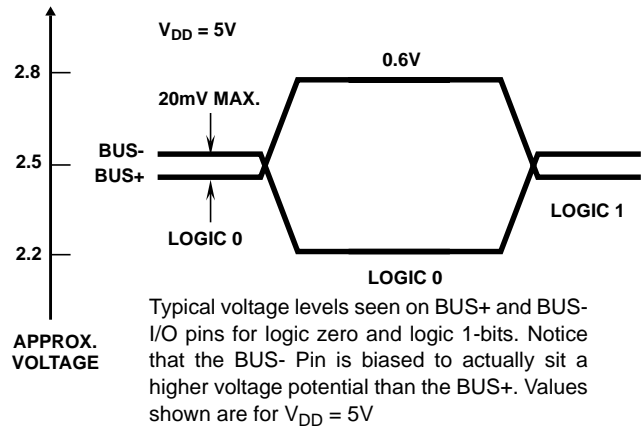
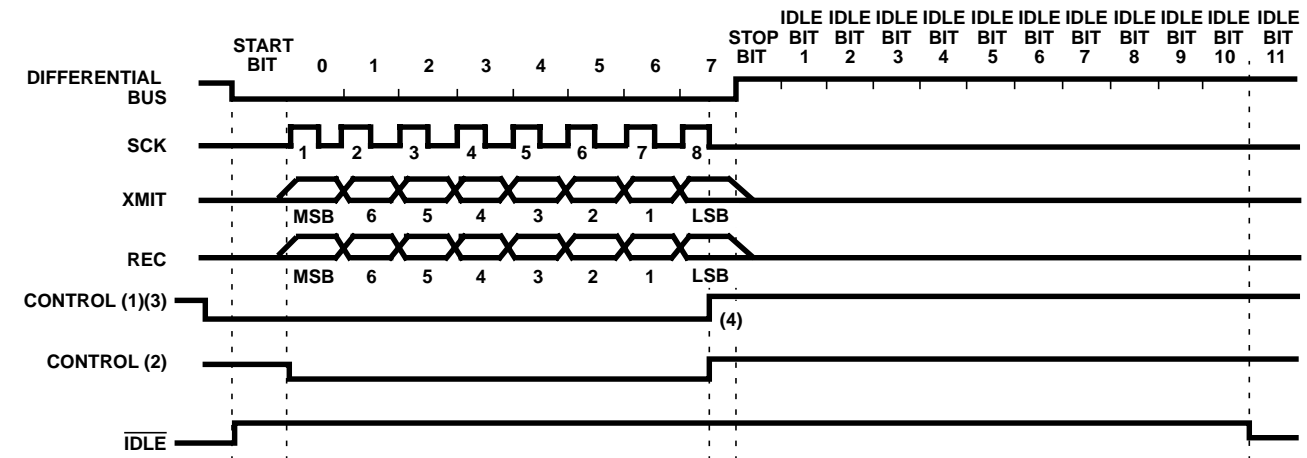

FIGURE 5.

The differential transceiver cell allows bus activity by other devices on the bus “+” and bus “-” I/Os when power to the cell is shut off. Therefore, this powered off condition places the transceiver outputs, BUS “+” and BUS “-”, in a high impedance state. When the cell is either being powered up or down, with or without bus activity, SCR latch-up protection is provided such that this activity is not affected.



NOTES:

1. The control signal at the transmitting node.
2. The control signal at the receiving node.
3. There is a delay between the control pin being pulled low and the actual beginning of the start bit.
4. If the control pin is again pulled low before the end of the stop bit, then the next start bit will begin at the end of the previous stop bit.

FIGURE 3. SCK, CONTROL, AND IDLE SIGNALS DURING THE SPI MODE OF OPERATION

Receive data is an output from the differential transceiver cell. It is the output of a differential amplifier which decodes the bus "+" and "-" I/O. When the bus "+" and "-" has been driven positive and negative respectively to a differential voltage value greater than V_{IDH} , the output of the differential amplifier is a logic one, which is inverted and considered a 0-bit from the bus. Otherwise, for level below V_{IDL} the differential amplifier output is a logic zero, which, in turn, is inverted and considered a 1-bit from the bus.

Twisted wire pair (or adjacent PC board traces) is recommended for the two differential bus lines.

The BREAK input, when held at a logic zero, (low) causes the differential transmitter driver to generate a continuous logic level zero on the differential bus. This action can generate a data collision which can be either used as a break or a request for arbitration by the system. When held at logic one, (high) this input has no effect on the operation of the cell.

The out of range output is normally a logic zero but goes to a logic one when the common mode voltage on both differential bus inputs exceeds a voltage value greater than V_{MAX} or less than V_{MIN} (see device specifications). This output is used by a latch to hold the received data at the logic level it was before the over range signal occurred.

Provided on chip is a power-on reset function. The transceiver cell's reset output is held to a logic zero on power up and switches to a logic one at or before V_{DD} rises to 4.0V. This output is used to ensure that other on-board logic has been properly initiated. During this reset time, the bus "+" and the bus "-" I/Os provide a high impedance state to the bus.

Bus Speed

SBIC systems typically use a bus speed of 7812.5 bits/second which is accomplished by using a 1MHz internal clock. However, no restriction on any other baud rate is designed into the chip, except its upper speed limit (see device specifications).

Bus Byte Format

All bytes transmitted on the bus follow the standard UART style asynchronous non-return-to zero data format consisting of start bit (logical zero) followed by 8 data bits (LSB first), and 1 stop bit (logical one).

Bus Message Format

All messages transmitted on the bus consist of a number of bytes, from 1 to N, with no restriction on length. The user must be aware, however, that the longer the message length, the greater the probability of collision with messages being transmitted at random from other masters on the bus. Typical message lengths of systems now in use range from 1 to 4 bytes.

The actual definition of each byte sent is left for the user to determine, i.e. the user must define the system protocol. For instance, a typical (and recommended) protocol might dictate that the first byte of each message sent be a unique address/identification byte. The first byte sent by a node (an MCU coupled with an SBI chip) might contain address information telling where (to which node[s]) the message is targeted for or where the message came from.

Other possibilities would be to identify the type of message sent (e.g. an instruction or just information) or the length of the message. The remaining bytes in each message can be merely data bytes that comprise the actual message. The user can even use the last byte as a check sum so that all receiving nodes can check for errors in transmission.

Messages are normally received by all nodes on the bus and may be processed by one or more micros, i.e., each MCU may decide, after receiving the first byte (address/ID byte) that this particular message is not needed for its operation. The MCU can then ignore the remainder of the message.

Prioritization

Since simultaneous transmission of address/ID bytes from several microcomputers is a possibility, a system of prioritization should be determined for bus arbitration. Due to the electrical characteristics of the differential data bus, each unique address/ID byte can automatically contain priority information used for bus arbitration. Merely use "lower" value ID bytes for higher priority messages. "Lower" value, in the SBIC case, means an ID byte with more zero's in its least significant locations. To further explain, since the differential bus transmits data least significant bit first and a zero overrides a 1-bit simultaneously transmitted by different nodes, an ID byte with least significant bit equal to zero will override an ID byte from a micro whose least significant bit is a one. If this does occur on-chip bus arbitration will automatically allow only one SBIC chip (with the highest priority address/ID byte) to continue transmitting. In this case it is the micro who transmitted the 0-bit. Assuming both ID bytes contain identical LSBs (bit 0) then arbitration is carried on to the next bit (bit 1), and soon.

Reflected Data

Whenever a microcomputer sends data through the SBIC and onto the differential bus, it will always receive reflected data back. The reflected data is the data that was actually seen on the bus. Keep in mind that during data collisions between simultaneously transmitting micros, zeroes override ones. In addition, any noise that may have been induced on the bus may alter the resultant reflected byte.

Bus Arbitration

Bus arbitration is the attempted transmission onto the differential bus of an initial byte (preferably an address/ID byte) by one or more user microcomputers. The purpose of bus arbitration is to enable a single microcomputer to obtain sole usage of the bus for the purpose of transmitting a message.

Bus arbitration is accomplished via a combination of methods which include an MCU software comparison of transmitted bytes to reflected bytes, the SBIC's collision detection circuit, and its start bit arbitration detector circuits.

Collision Detection

The SBIC's collision detector circuit compares the bits being sent from a user microcomputer to the reflected byte simultaneously received back from the differential bus. If the collision detector detects a difference in the data, it immediately blocks the user microcomputer's transmitted data from fur-

ther reaching the bus. This will happen, as stated in the "Prioritization" section, when a micro with a higher priority address/ID byte attempts "simultaneous" transmission (actually, i.e. within a time window of 1/4 bit time). That micro, with a higher priority ID byte, is obviously sending a 0-bit and its reflected byte matches the byte it is sending. Not detecting a collision, it continues to transmit its message, while the lower priority MCU is cut off from transmitting on the bus. The lower priority micro will be inhibited from transmitting on the bus until the message presently on the bus has ended (EOM = "End of Message" condition).

End of Message Condition

After transmitting the last byte of a message, the transmitting MCU must generate an End of Message (EOM) condition. An EOM condition is defined as a 10-bit length idle condition, i.e., the bus must remain idle (logic1) for a period of 10-bit times (1280 internal clock periods). This can be done by merely creating a 10-bit delay in MCU software.

Start Bit Arbitration Detection

Arbitration, as discussed above, is only necessary when two or more micros attempt to transmit within 1/4 bit time (32 internal clock periods) of each other. Otherwise, once a micro begins a transmission on the differential data bus, all

other SBI chips sense the start bit and inhibit their microcomputers from transmitting (again, after a 32 clock period arbitration window delay). Once the arbitration detector circuit has blocked an MCU's transmission, access to the bus will be blocked until an End of Message condition.

Start of Message Delay

In order to properly synchronize various MCU's (which may be using different modes of operation) for impartial arbitration, each node must delay 2-bit times (256 internal clock periods) after detecting the IDLE signal drop low before transmitting, i.e., before the start bit of the next message reaches the bus. When using the SPI or Buffered SPI modes, this delay is automatically designed into the SBI chip. However, when using the SCI mode, the MCU must support this required delay. Fortunately, 68HC05 microcomputers using the SCI port will inherently experience a delay between the time that the SCI data register is loaded and the time that the start bit actually appears on the SCI port transmit pin (TxD). At a baud rate of 7812.5 bps this delay can be as long as 256 SBI chip internal clock periods. If this is so, then the user MCU does not have to worry about providing this delay.

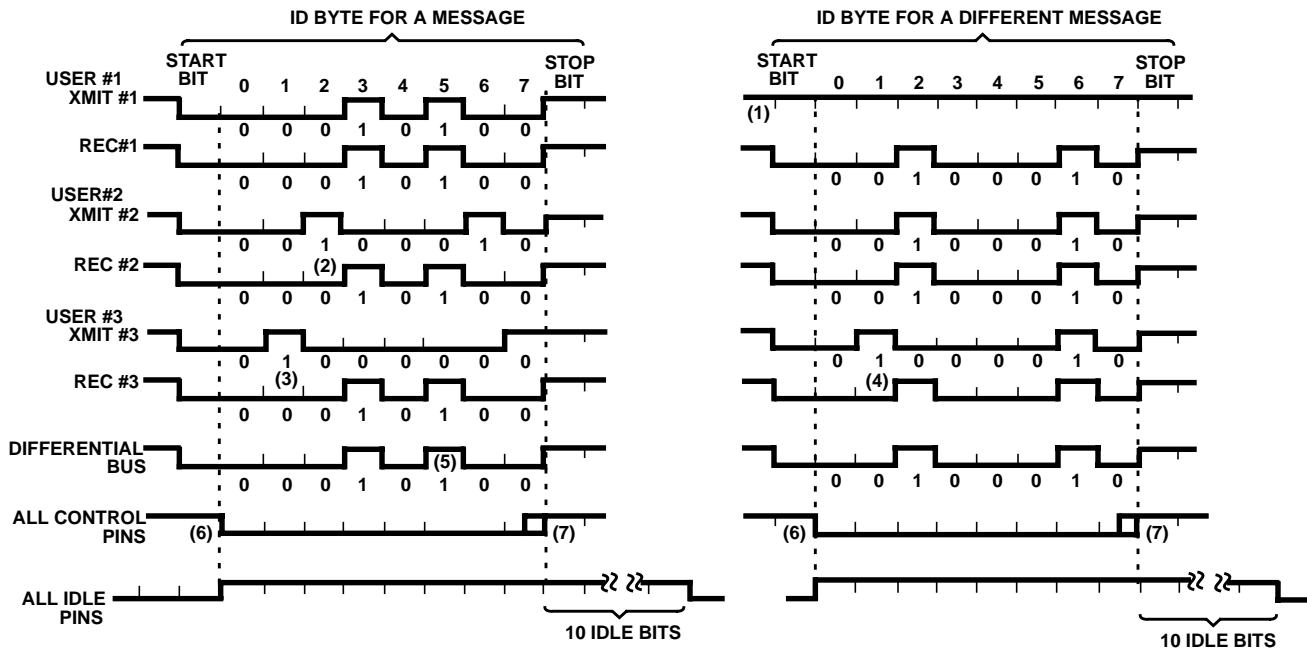

NOTES:

1. USER #1 is note transmitting + marking.
2. Point at which USER #2 loses bus arbitration.
3. Point at which USER #3 loses bus arbitration.
4. Point at which USER #3 loses bus arbitration.
5. This '1' bit is not overridden by the '0' bits from users 2 and 3 because both users 2 and 3 have previously been blocked from bus access due to data collisions.
6. The control pin on the transmitting node goes low earlier in both SPI modes (it is pulled low by micro).
7. The control pin remains low until the end of the last data bit of the 2 byte set when using the buffered SPI mode, but goes high at the middle of the last data bit in other modes.

FIGURE 6. EXAMPLE OF THE SCI CHIP OPERATING DURING BUS ARBITRATION

Idle Detection

An idle detector circuit is used to detect when the differential bus is in the idle condition, i.e., no user microcomputer has control of the bus and the bus is sitting at a mark condition (a logic one). The idle detector senses a received stop bit and delays for a short idle period of 10-bit times, during which the bus must remain idle. The idle output pin is then set to a logic zero (true). It is later set to a logic one by receiving a start bit. During the 10-bit time delay, if a non-idle condition such as noise is detected on the bus, the delay period counter will be restarted.

Due to the 10-bit time idle delay period, once an MCU wins bus arbitration, it should send the next data byte to be transmitted within a period of 10-bit times (1280 internal clock periods). Each subsequent data byte to be sent should also not exceed the interbyte maximum of 10-bit times. If this maximum is exceeded, all SBIC chips will have detected the idle condition and now pull their idle lines low and reset their bus arbitration and collision detection circuits, thereby allowing other SBI chips with messages to send to arbitrate for the bus. Figure 6 shows the detailed operation of the serial bus interface chip during bus arbitration. This example shows the arbitration of a single byte (e.g. the address/ID byte) from three different user microcomputers. Two full arbitration cycles are shown.

Break Generator

A request for arbitration can be generated by a node that needs to interrupt transmission of a long data string. This can be accomplished by forcing the SBIC's IDLE pin to a logic zero; this forces a data collision (by sending 0-bits) after three data bytes have been transmitted, and the transmitting MCU is required to detect this break condition and stop transmitting. It is, however, allowed to re-arbitrate for the bus and the interrupting mode may not generate a second break condition if it loses arbitration.

Using the CDP68HC68S1

Following are some hardware and software recommendations for using CDP68HC68S1 Serial Bus Interface Chip. Requirements may vary depending upon the user's system configuration.

Hardware (General)

The differential bus lines (BUS+ and BUS-) must be terminated with external resistors as shown in Figure 4. This applies, however, only to one node (an MCU/SBIC pair) along the bus. Since all SBI chips are wired in parallel across the network bus, there is no need for additional 13K bias resistors at each node. The 120Ω termination resistors should, however, be present at two nodes if the network does indeed contain two or more nodes. The 120Ω resistor provides the voltage drop across which the SBI chip senses logic zero and logic 1-bits. If two nodes each utilize 120Ω termination resistors as shown in Figure 7A, the effective resistance across the BUS+ and BUS- pins drop to 60Ω total (due to the parallel wiring method). Any less resistance would not provide an ample voltage drop for the receiver cell op amp to sense. Following these guidelines, typical systems might look like those shown in Figure 7.

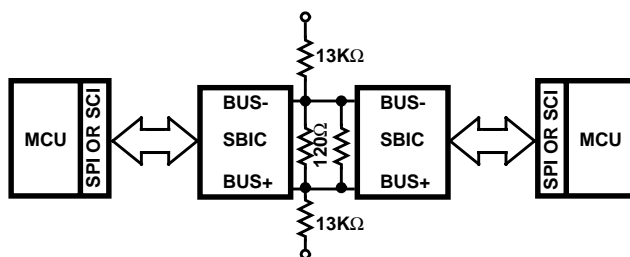

NOTE: Hardware configuration for a network consisting of two microcomputers. Notice that the pullup resistor is connected to the BUS- pin and the pulldown to BUS+.

FIGURE 7A.

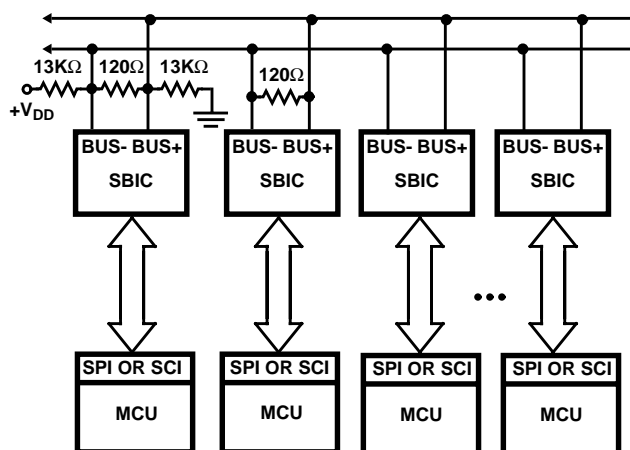

NOTE: Hardware configuration for a network consisting of 3 or more MCU's. Notice that the bus utilizes no more than 1 set of 13K bias resistors and no more than two 120Ω termination resistors.

FIGURE 7B.

FIGURE 7. HARDWARE CONFIGURATION FOR A NETWORK OF MICROCOMPUTERS

Software (General)

Although each user's protocol may vary, the following general procedure should be followed when using the SBI chip in any mode:

When a microcomputer is preparing to transmit a message it should monitor the SBIC's IDLE pin and wait for it to go low (logic zero) indicating the bus is idle. Then the MCU attempts to transmit the first byte (preferably an Address/ID byte). If no other MCUs are transmitting at this time, or if this MCU has the highest priority ID byte, the SBI chip's collision detector circuit will permit transmission.

The microcomputer must then confirm transmission by reading the byte reflected back from the bus. If this byte matches the byte transmitted then the MCU has gained control of the bus and may continue to transmit the remainder of the message (if any).

If the reflected byte does not match the ID byte sent then the MCU has not gained control of the bus and may not presently transmit. It should, however, check the reflected ID byte to see if the incoming message (i.e. the message from

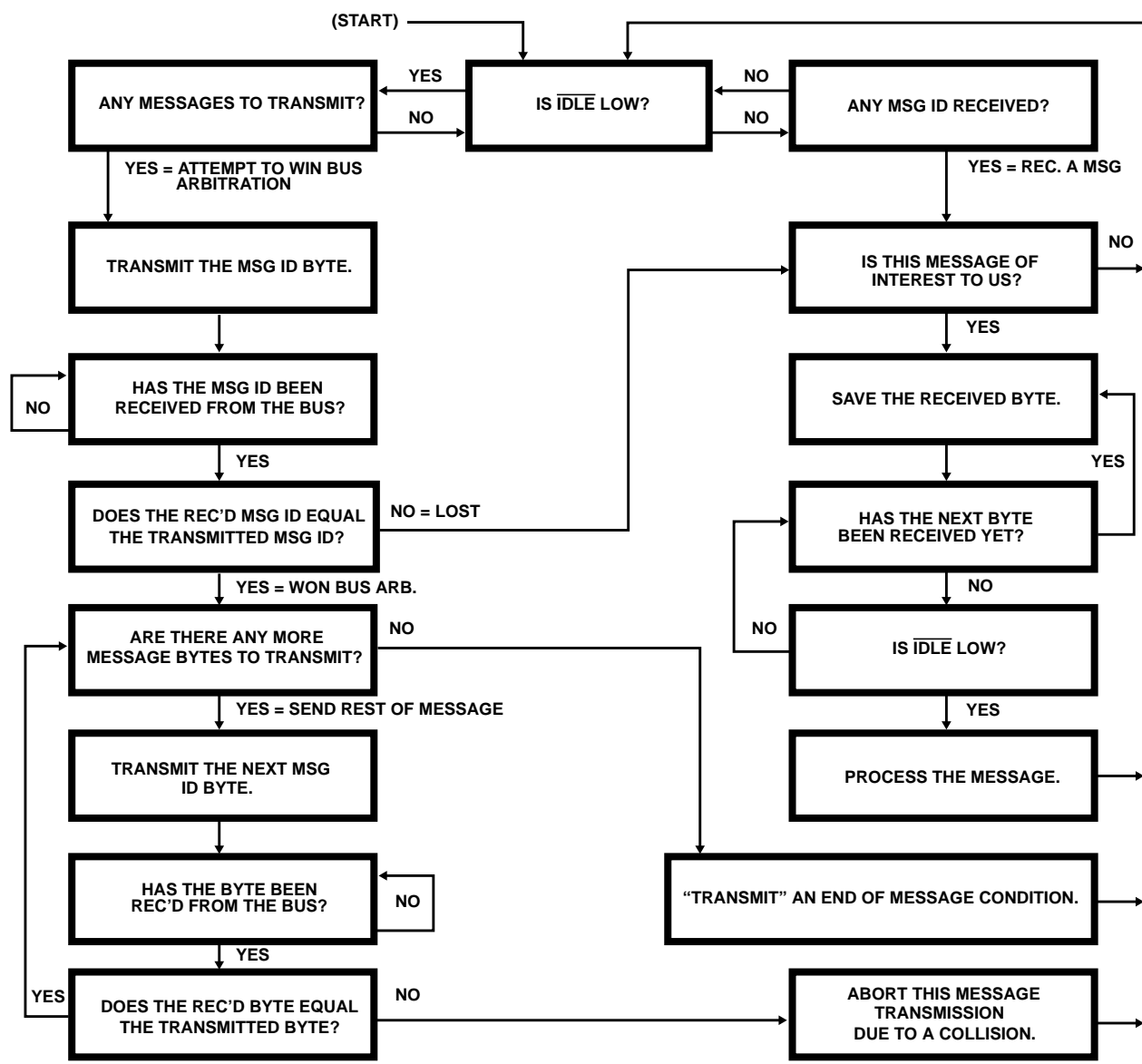

FIGURE 8. GENERAL MESSAGE PROCESSING.

the arbitration-winning MCU) is of any interest. If so, it should save the incoming message (the length of which may be specified in the ID byte) and then wait for the $\overline{\text{IDLE}}$ line to go high before re-attempting transmission (if still desired). The flowchart in Figure 8 reflects this procedure.

The SCI Mode, Hardware

In the SCI mode, the TxD and RxD pins on the user microcomputer must be connected to the XMIT and REC pins on the SBIC chip, respectively, as shown in Figure 9. The MCU's SCI port should be configured for the same baud rate and character format as that used by the bus interface (i.e. 1 start bit, 8 data bits and 1 stop bit). The start and stop bits are used to synchronize the data, a byte transfers between the user microcomputer and the SBI chip. When using the SCI mode, the SBI chip should always be properly mode and chip selected. This can be accomplished by either a user microcomputer output signal or by permanent wiring. This is

required in order to always be able to receive messages from other microcomputers on the bus, which can happen at random. For the SCI mode, the SBI chip's MODE pin must be set to 1 and the $\overline{\text{CS}}$ pin to 1.

SCI Mode, Software

The procedure to follow for transmitting/receiving in the SCI mode is basically identical to that stated in the "Using the CDP68HC68S1-Software" section above, with the following exception:

Start of Message Delay

Transmitting a byte via the 68HC05 SCI port basically requires loading the byte into the MCU's SCI data register (once the SCI port is initialized). However, after the SBIC's $\overline{\text{IDLE}}$ pin drops low, the user may have to create a delay before transmitting the FIRST byte of a message; this necessary 2-bit time (256 internal clock periods) delay is called the Start of Message (SOM)

delay. Fortunately, SCI ports exhibit an inherent delay between the loading of the transmit data buffer and the actual beginning of the start bit appearing on the TXD pin. This delay, at 7812.5 Baud, can be as long as 256 SBI chip internal clock periods and can be used to synchronize SCI users with SPI and Buffered SPI users to ensure impartial bus arbitration. The delay for a particular microcomputer must be determined by the user. If this inherent delay is less than 256 clock periods, then the user must delay the loading of the first byte enough to ensure that the total delay including the inherent delay of the SCI port is 256 clock periods.

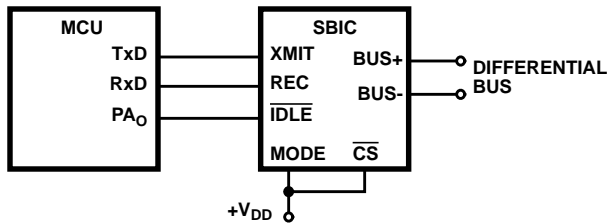

FIGURE 9. USING THE SCI MODE

Monitoring the IDLE Pin

The user microcomputer must monitor the IDLE pin on the SBIC chip in order to determine when a message ends, when the next received byte is a Msg ID byte, and when to attempt arbitration if the user microcomputer has a message to transmit.

The user microcomputer must be able to both detect when the IDLE signal goes from high to low and sense at other times whether it is either high or low. Detecting the change from high to low is necessary in order to know exactly when the bus goes idle. An MCU can then begin bus arbitration by attempting to transmit. Being able to sense the level of IDLE is necessary in order to be able to start transmitting a message sometime after IDLE has gone low but no other user on the bus has had a message to transmit for a length of time.

Instead of polling the IDLE pin via an MCU input pin, the user may wish to conserve CPU time by using interrupts to monitor bus activity. The user microcomputer's external interrupt pin (IRQ) can be used to edge detect the IDLE pin for high to low transitions.

Using 68HC05 SCI Port Flags

During message reception, the 68HC05 SCI port receive data register full flag (RDRF), and optionally its associated interrupt, can be used by the user microcomputer to determine when to unload the next received byte.

The user may wish to ignore the RDRF flag and disable the RDRF interrupt during reception of an unwanted message. In this case the user can merely wait for the IDLE pin to go low before attempting any further actions.

The normally available transmit data register empty flag (TDRE) can be used to determine when to load the next byte to be transmitted onto the bus. If there are no more bytes to be transmitted, then consider the last message as having been transmitted, and generate an End Of Message (EOM) (i.e. transmit a logic 1 for 10 contiguous bit times by creating a software delay).

Framing Errors

While in the SCI mode, the SBI chip is capable of detecting incoming framing errors. It will do this even though the incoming signal is also echoed to the user microcomputer, which should also detect the framing error via its' UART. When a framing error is detected by the SBI chip, the generation of the SCK pulses is terminated until an End Of Message is detected.

The SPI Mode Hardware

The Master Out Slave In, (MOSI), and Master In Slave Out, (MISO), pins on the user microcomputer are connected to the REC and XMIT pins of the SBI chip, respectively, as shown in Figure 10. The SCK pins on the user microcomputer and the SBI chip are connected together. Synchronization of data transferred between the user microcomputer and the SBI chip is done by using the SCK signal provided by the SBI chip.

In the SPI mode of operation the SBI chip should always be properly mode selected. This may be accomplished either by a user microcomputer output signal or by permanent wiring in order to guarantee that the SBI chip will always be able to receive messages from other microcomputers on the bus, which may happen at random. To select the SPI mode, set the MODE pin to a logic 1 and the CS pin to a logic 0.

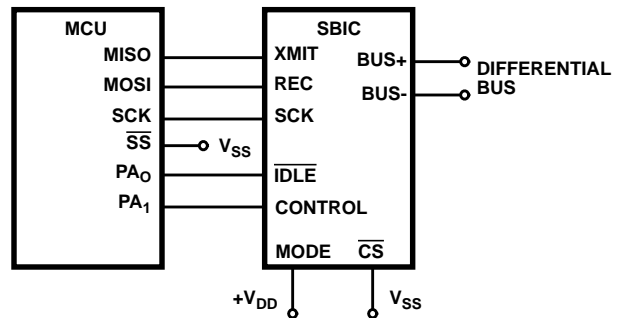

FIGURE 10. USING THE SPI MODE

The user microcomputer should configure its SPI port for slave mode operation with SCK positive polarity and data transfer on SCK leading edge (i.e. CPOL = 0, CPHA = 1, for 68HC05 microcomputers). 8-bit data transfers between the user microcomputer and the SBI chip occur at differential bus transfer speed.

In the SPI mode, the user microcomputer operates in the slave mode and the SBI chip operates as the master. The SS pin on the user microcomputer must be wired low or forced low whenever the SBI chip has incoming data. It may be useful to connect the CONTROL pin of the SBI chip to the Slave Select (SS) pin of the 68HC05 microcomputer. The SBI chip will then control the user microcomputer's SPI port. The user microcomputer can request transmission of data onto the bus by the SBI chip by loading data into its SPI data register and then pulling the SBIC's CONTROL pin low (for at least 1µs). However, it must do so before the SBI chip has begun to receive data from another MCU.

SPI Mode, Software

The SPI mode is similar to SCI mode in that the user microcomputer sends/receives data to/from the SBI chip 1 byte at a time. In the SPI mode, however, the user microcomputer must reverse the bit order of transmitted and received bytes. When transmitting a message, each bit of a transmitted byte is simultaneously transmitted onto the bus and a reflected bit is simultaneously received from the bus.

Monitor and Control of the CONTROL Line

In the SPI mode, the user microcomputer monitors the CONTROL pin on the SBI chip in order to determine if the SBIC is ready to accept a transmit request. Actually, a data collision may still occur and the user microcomputer must always be ready to handle it.

The CONTROL signal is normally high and goes low when data is on the bus or when pulled low by the user microcomputer. After being pulled low by the user microcomputer, which signals a request to begin the transmission data, the CONTROL signal will latch low and stay low until the middle of the last data bit has been transmitted and appears on the bus.

The CONTROL signal will also go low at the beginning of the first data bit, when received from the bus. It will then go high at the middle of the last data bit.

When the SBI chip begins to receive a byte of data from the bus and the user microcomputer has not pulled the SBIC's CONTROL line low, the SBI chip will pull CONTROL low and start generating the SCK clock signal. As each data bit is received it is clocked out of the SBI chip and into the user microcomputer. Any data in the user microcomputer's SPI data register will be transferred out and into the SBI chip.

The CONTROL signal will go high at the midpoint of the eighth data bit. This will allow the user microcomputer to have enough time to review the just received SPI data and reload it, if further data is needed to be transmitted. However, it must again pull the CONTROL pin low to signal the SBI chip that it should begin transmitting. As a slave to the SBI chip, the user microcomputer must be able to handle the incoming data on the SPI port without affecting its other software routine functions.

Detecting $\overline{\text{IDLE}}$ via a User Microcomputer External Interrupt

The user microprocessor's external interrupt should be set to edge detect $\overline{\text{IDLE}}$ for falling transitions, i.e. EOM detection. If possible, detect CONTROL for rising transitions, for byte transmission/reception complete detection.

Use of Internal User Microcomputer Flags and Interrupts

The normally available SPI finished flag (SPIF) and optionally its associated interrupt may be used by the user microcomputer to know when a byte transmission/reception is complete.

The user microcomputer should be ready to handle the Write Collision, WCOL, error flag. The WCOL flag is set when a collision is detected in the SPI port. This will occur when the user microcomputer tries to load a byte into the SPI data register after the SBI chip has already begun to load data into the SPI port.

Sending Messages to Other Microcomputers on the Bus

In order to send a message to other microcomputers on the bus while in the SPI mode the user microcomputer should:

1. Monitor the $\overline{\text{IDLE}}$ pin and determine if the bus is currently busy or if a transmission may be immediately started.
2. Monitor CONTROL to determine if it is ok to load the byte to be transmitted into the user microcomputer's SPI data register.
3. Load the byte to be transmitted into the SPI data register.
4. Pull the CONTROL pin low to signal the SBI chip to start a byte transmit cycle.
5. Wait until the byte transmit cycle is completed as signaled by the SPI Finished, SPIF, flag/interrupt in the SPI port or by the CONTROL signal going high.
6. Compare the received byte with the last transmitted byte.
7. If the received byte equals the last transmitted byte, and more bytes remain to be transmitted, then continue the cycle with step #3. If there are more messages to transmit, then go to step #1. If there are no more bytes to be transmitted, then consider the message as having been transmitted, and generate an End Of Message (EOM) (i.e. delay for 10 contiguous bit times). Go to step #1.
8. If the received byte does not equal the last transmitted byte and this is the first byte of a message, then treat the received byte as the first byte of a received message (i.e. the ID byte). Attempt to retransmit the previous message after the $\overline{\text{IDLE}}$ signal has gone low again. If this happens during the transmission of a later message byte, other than the ID byte, then consider it due to either an erroneous data collision on the bus or due to noise collisions on the bus causing the message to have to be re-transmitted. Go to step #1.

Framing Errors

While in the SPI mode, the SBI chip is capable of detecting incoming framing errors. If one is detected, generation of the SCK pulses to the user microcomputer is terminated. The SBI chip essentially quits receiving data and starts looking for an End Of Message. Resetting of the SCK generator will occur upon receiving an EOM. Meanwhile, software must be prepared to resynchronize the micro's SPI port; this can be done by disabling and then reinitializing it.

Even though the SBI chip can detect framing errors, it can not flag the user microcomputer that one has occurred. Since the previously received byte has already been transferred to the user microcomputer, the SBI chip will simply refuse to accept any further incoming data until an EOM occurs. Thus, one way that the user microcomputer may detect that the received data is valid, is via using a check sum byte imbedded within each message. Another way would be to compare the number of bytes received for a particular ID to the number expected for that ID.

Buffered SPI Mode, Hardware

The MOSI and MISO pins on the user microcomputer should be connected to the XMIT and REC pins of the SBI chip respectively. The SCK pins on the user microcomputer and

the SBI chip should also be connected together, as shown in Figure 11. Synchronization of the data that is transferred between the user microcomputer and the SBI chip is done by the SCK signal which is provided by the user microcomputer.

The Slave Select (\overline{SS}) pin on the user microcomputer must be wired high or forced high whenever the SBI chip is selected.

The user microcomputer should configure its SPI port for master mode operation, SCK low polarity, and data transfer on first edge (i.e. CPOL = 0, CPHA = 1 for 68HC05 microcomputers).

The SBI chip must be chip selected either by a user microcomputer output signal or by permanent wiring of its pins. To select the Buffered SPI mode, set the MODE pin and the \overline{CS} pin to logic zero. This is required in order to transfer data between the SBI chip and the user microcomputer. However, in the Buffered SPI mode, since the MCU is operating as a master and controls the SPI port, chip selection is only required during when the SPI transfers are actually occurring.

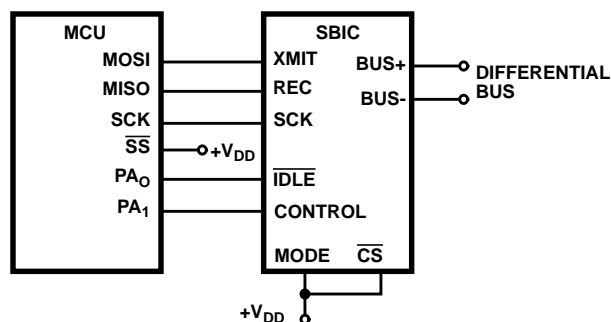

FIGURE 11. USING THE BUFFERED SPI MODE

Buffered SPI Mode, Software

The principle difference between the Buffered SPI mode and the normal SPI mode is the use of a 2 byte internal buffer. Also, the Buffered SPI mode allows the user microcomputer to operate in the master mode, instead of the slave mode, which allows high speed transferring of data between the SBI chip's buffer and the user microcomputer.

For typical operation, the user microcomputer loads the SBI's 2 byte buffer, at a high speed, using its SPI interface. The 68HC05's SPI Finished flag (SPIF), and optionally its associated interrupt, may be used by the user microcomputer to know when the transfer of a byte between the user microcomputer and the SBI chip is complete. Then it signals the SBI chip, by pulling its CONTROL line low, to transmit the data in the buffer onto the differential bus.

The SBI chip, at a differential bus speed, then attempts to transmit the buffered data onto the bus. During this attempt, the SBI chip will receive two reflected bytes of data back from the bus, store them in the buffer and then disable the buffer from receiving further data from the differential bus until this received data is later unloaded by the user microcomputer at high SPI transfer speeds. The MCU should also, at this time, simultaneously load the next 2 bytes of data to be transmitted into the buffer.

While it is transmitting and receiving the 2 bytes of data on the differential bus the SBI chip will not allow transfer of data to and from the user microcomputer. In fact, the SBI chip does not need to be chip selected during this time.

The bus will override the user microcomputer if incoming data is received during the time when the user microcomputer is performing a data transfer, after having unloaded the previous 2 bytes. The data from the differential bus will be loaded into the SBIC buffer, while the data from the user microcomputer will be lost. The data that the user microcomputer will receive during this transfer, is undefined. The user microcomputer has no way of knowing its transfer has been aborted unless it either monitors the CONTROL signal for a rising transition or by detecting that CONTROL was not high at completion of the SPI transfer.

Monitoring the Control Signal

The user microcomputer should monitor the CONTROL signal on the SBI chip, in order to determine whether it is actively transmitting or receiving data. The CONTROL signal is used to determine who has access to the 2 byte buffer. During data reception or transmission to the differential bus by the SBIC its CONTROL pin is low signifying that the differential bus now has access to the SBIC and the MCU is locked out from accessing the SBIC. Then when 2 bytes of data have been received from the differential bus, the SBI chip will pull its CONTROL line high, signaling to the MCU that the MCU can now access the SBIC's 2 byte buffer. The MCU may now read the 2 bytes received and simultaneously transmit two more bytes (if desired) by performing a 2 byte transfer (a swap of data), via the MCU SPI port, with the SBIC; then the MCU pulls the SBIC's CONTROL pin low to transmit the two new bytes. The CONTROL pin will remain latched low (by the SBIC) until the two new bytes are transmitted.

The user microcomputer should also monitor the \overline{IDLE} signal in order to accurately know when the bus is idle or when bus arbitration is occurring, when a received message has finished, and when the next bytes to be received are the beginning bytes of a new message. Preferably, the user microcomputer's external interrupt should be set up to edge detect falling \overline{IDLE} and rising CONTROL transitions.

When the CONTROL pin goes high, it signals that the buffer is full and that the user microcomputer currently has access. When the \overline{IDLE} pin goes low, it is signaling that the current message has been completed, and an MCU may now arbitrate for the bus.

Size of Messages that can be Transmitted or Received

In the Buffered SPI mode, the user microcomputer can only send messages in 2 byte multiples. Transmitting messages with an odd number of bytes, to other microcomputers on the bus, is NOT supported by the SBI chip in Buffered SPI mode. However, reception of any number of bytes is supported.

In the Buffered SPI mode, the user microcomputer can receive messages of any length. For odd length messages, the user microcomputer must know when the message is finished either from the message ID byte or via the \overline{IDLE} signal. Since the SBI chip will give no indication as to whether the buffer contains one or 2 bytes of information from the bus, the message length should be contained within the message data bytes.

When a single byte is received from the bus, followed by a bus idle condition, the SBI chip will, as it normally does when the buffer has received 2 bytes, set the CONTROL signal high. It will then relinquish control of the buffer for data transfer via the user microcomputer, and restrict access to the buffer from incoming bus data until the 2 byte data transfer has been completed.

If only 1 byte is received from the bus, the user microcomputer will receive it first when performing the 2 byte data transfer. The second byte received by the user microcomputer, during this transfer, is undefined. A 2 byte transfer is still required in order to return control of the buffer back to the SBI chip, to gather further incoming data from the bus.

Power On/Reset

The SBI chip is reset internally, at power on. After reset, the CONTROL pin is set high and IDLE is set low. The buffer access is set as though 2 bytes have just been received from the bus. A 2 byte transfer must be performed, via the user microcomputer, in order to initialize the SBI chip for general operation.

Sending Messages to Other Microcomputers on the Bus

In order to send a message to other microcomputers on the bus, while in the Buffered SPI mode, the user microcomputer should:

1. Monitor the SBIC CONTROL pin to know when it is ok to perform the 2 byte transfer between the user microcomputer and the SBI chip.
2. Perform the 2 byte transfer between the user microcomputer and the SBI chip for the first 2 bytes of the message.
3. Pull CONTROL low to tell the SBI chip to start a 2 byte bus transmit cycle.
4. Wait until CONTROL goes high again indicating that the 2 byte transmit cycle has completed.
5. Perform another 2 byte transfer between the user microcomputer and the SBI chip, thus giving it the next 2 bytes to be transmitted and giving the user microcomputer the 2 bytes just received.
6. Compare the just received 2 bytes with the 2 bytes which were attempted to be transmitted.
7. If the received and last transmitted bytes are equal and more bytes remain to be sent, then continue the cycle with step #3.
8. If the received and last transmitted 2 bytes are unequal, then restart with step #2.

Creating an EOM after a Message Transmission

There must be at least a 10-bit interval of bus idle between the stop bit of the last byte of one message and the detection of the start bit of the first byte of the next message. This can be implemented by either:

1. Including a 10-bit interval time out, via using a timer or software loop.
2. The user microprocessor can simply wait until it senses IDLE going low.

Receiving Messages from Other Microcomputers on the Bus

If the user microcomputer loses arbitration, or if it has no message to transmit and another microcomputer begins to send its message onto the bus, the SBI chip will begin to receive a message from the bus.

The SBIC CONTROL pin will go low at the beginning of the first data bit that is received from the bus. It will go high either whenever 2 bytes have been received, or when 1 byte has been received followed by the bus going idle (i.e. when IDLE goes low).

The transition of CONTROL from low to high indicates that the SBI chip has 2 bytes in its internal buffer for the user microcomputer to retrieve. Whether the SBI chip has received either 1 or 2 bytes, the user microcomputer must perform a 2 byte transfer in order to return control of the buffer back to the SBI chip.

The user microcomputer must detect CONTROL going high and transfer the 16-bits from the SBI chip before the beginning of the first data bit of the next message or else the bus will be locked out of accessing the buffer until after both the next 16-bit transfer is complete and IDLE goes low. Thus, if there was further incoming data and this did occur, some of the incoming data may be lost.

Framing Errors

While in the Buffered SPI mode, the SBI chip is capable of detecting incoming framing errors, however it is unable to flag this to the user microcomputer. When the SBI chip detects a framing error, any further loading of the SBI chip's internal buffer is terminated. The SBI chip essentially quits receiving data and starts looking for an End Of Message. Resetting of the framing error will occur upon receiving an EOM.

Even though the SBI chip can detect framing errors, it can not flag the user microcomputer that one has occurred. Since the previously received byte has already been loaded into the SBI chip's buffer, the user microcomputer must determine whether this data is valid. If a framing error occurs during the first byte of a 2 byte reception, access to the buffer will be restricted from the user microcomputer until an EOM occurs. If a framing error occurs during the second byte of a 2 byte reception, the user microcomputer will be given access to the buffer. However, even if the user microcomputer unloads the buffer, the SBI chip will not load any further data into the buffer until an EOM occurs. Basically, when a framing error occurs, no further data is read from the bus and buffer access is given to the user microcomputer either immediately or upon an EOM.

One way that the user microcomputer may detect that the received data is valid, is by using a check sum byte imbedded within each message. Another way would be to compare the number of bytes received for a particular ID to the number expected for that ID.

References

Portions of the information contained in this document were taken and condensed from Chrysler Corporation's "CCD USER'S MANUAL" issued April 15, 1987.

This datasheet has been downloaded from:

www.DatasheetCatalog.com

Datasheets for electronic components.



LittleDiode supplies new, hard to find or obsolete electronic components and semiconductors all over the world.

With over two million different components listed you are sure to find the part you need.

Feel free to visit us today at our online store:

LittleDiode.com

Looking forward to providing you with the best possible service.