

Capacitive digital sensor for relative humidity and temperature

Datasheet - preliminary data

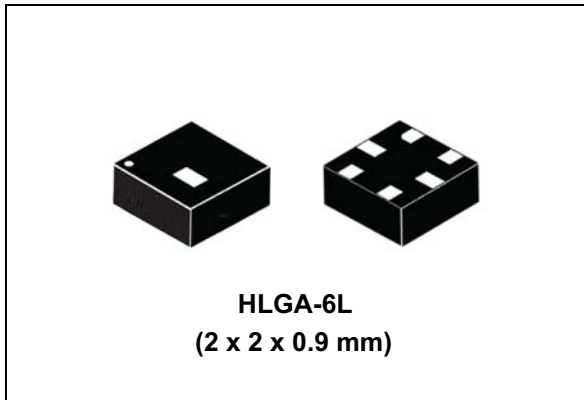

Features

- 0 to 100% relative humidity range
- Supply voltage: 1.7 to 3.6 V
- Low power consumption: 2 μ A @ 1 Hz ODR
- Selectable ODR from 1 Hz to 12.5 Hz
- High rH sensitivity: 0.004% rH/LSB
- Humidity accuracy: \pm 4.5% rH, 20 to +80% rH
- Temperature accuracy: \pm 0.5 $^{\circ}$ C, 15 to +40 $^{\circ}$ C
- Embedded 16-bit ADC
- 16-bit humidity and temperature output data
- SPI and I²C interfaces
- Factory calibrated
- Tiny 2 x 2 x 0.9 mm package
- ECOPACK[®] compliant

Applications

- Air conditioning, heating and ventilation
- Air humidifier
- Refrigerators
- Wearable devices
- Smart home automation
- Industrial automation

Description

The HTS221 is an ultra compact sensor for relative humidity and temperature. It includes a sensing element and a mixed signal ASIC to provide the measurement information through digital serial interfaces.

The sensing element consists of a polymer dielectric planar capacitor structure capable of detecting relative humidity variations and is manufactured using a dedicated ST process.

The HTS221 is available in a small top-holed cap land grid array (HLGA) package guaranteed to operate over a temperature range from -40 $^{\circ}$ C to +120 $^{\circ}$ C.

Table 1. Device summary

Order codes	Temperature range [$^{\circ}$ C]	Package	Packing
HTS221TR	-40 to +120	HLGA-6L	Tape and reel
HTS221			Tray

Contents

- 1 HTS221 block diagram 4**
 - 1.1 Pin information 4
- 2 Sensor parameters and electrical specifications 6**
 - 2.1 Communication interface characteristics 7
 - 2.1.1 SPI - serial peripheral interface 7
 - 2.1.2 I²C - control interface 8
 - 2.2 Absolute maximum ratings 9
- 3 Functionality 10**
 - 3.1 IC interface 10
 - 3.2 Factory calibration 10
- 4 Application hints 11**
 - 4.1 Soldering information 11
- 5 Digital interfaces 12**
 - 5.1 I²C serial interface (CS = HIGH) 12
 - 5.1.1 I²C operation 13
 - 5.2 SPI bus interface (CS = LOW) 15
 - 5.2.1 SPI write 15
 - 5.2.2 SPI read 16
- 6 Register mapping 17**
- 7 Register description 18**
 - 7.1 WHO_AM_I 18
 - 7.2 AV_CONF 18
 - 7.3 CTRL_REG1 19
 - 7.4 CTRL_REG2 20
 - 7.5 CTRL_REG3 21
 - 7.6 STATUS_REG 21
 - 7.7 HUMIDITY_OUT_L 22

7.8	HUMIDITY_OUT_H	22
7.9	TEMP_OUT_L	22
7.10	TEMP_OUT_H	23
8	Humidity and temperature data conversion	24
9	Package mechanical section	27
10	Revision history	29

1 HTS221 block diagram

Figure 1. HTS221 block diagram

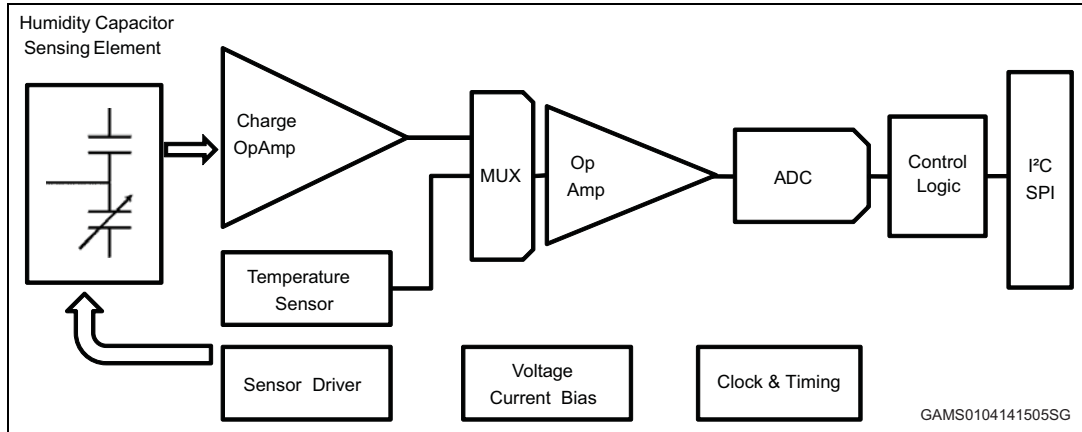

1.1 Pin information

Figure 2. Pin configuration (bottom view)

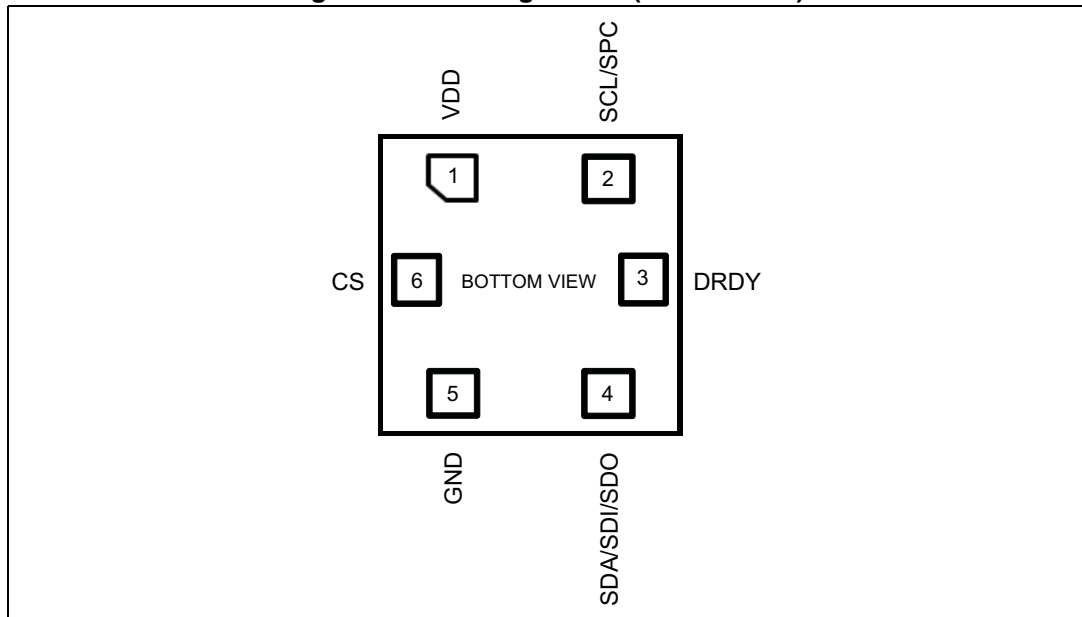

Table 2. Pin description

Pin n°	Name	Function
1	V _{DD}	Power supply
2	SCL/SPC	I ² C serial clock (SCL) SPI serial port clock (SPC)
3	DRDY	Data Ready output signal
4	SDA/SDI/SDO	I ² C serial data (SDA) 3-wire SPI serial data input /output (SDI/SDO)
5	GND	Ground
6	CS	I ² C/SPI mode selection 1: SPI idle mode / I ² C communication enabled 0: SPI communication mode / I ² C disabled

2 Sensor parameters and electrical specifications

Conditions at $V_{DD} = 2.5\text{ V}$, $T = 25\text{ °C}$, unless otherwise noted.

Table 3. Humidity and temperature parameter specifications

Symbol	Parameter	Test condition	Min.	Typ. ⁽¹⁾	Max.	Unit
H _{op}	Operating humidity range		0	–	100	% rH
H _{bit}	Humidity output data			16	–	bit
H _s	Humidity sensitivity			0.004		%rH/LSB
				256		LSB/%rH
H _{acc}	Humidity accuracy ⁽²⁾	20 to 80 % rH		±4.5		% rH
		0 to 100 % rH		±6		
H _{noise}	Humidity noise ⁽³⁾			0.03		RMS
H _{hys}	Humidity hysteresis			±1		% rH
H _{step}	Humidity response time ⁽⁴⁾	t @ 63%		10		s
H _{drift}	Humidity long term drift	20 to 80 % rH		0.5		%rH/yr
T _{op}	Operating temperature range		-40	–	120	°C
T _{bit}	Temperature output data			16	–	bit
T _s	Temperature sensitivity			0.016		°C/LSB
				64		LSB/°C
T _{acc}	Temperature accuracy	15 to 40 °C		±0.5		°C
		0 to 60 °C		±1		
T _{noise}	Temperature noise ⁽⁵⁾			0.007		RMS
T _{step}	Temperature response time	t @ 63%		15		s
T _{drift}	Temperature long term drift	T= 0 to 80 °C			0.05	°C/yr
ODR	Humidity and temperature digital output data rate			1/7/12. 5		Hz

1. Typical specifications are not guaranteed
2. Accuracy in non condensing environment including hysteresis
3. Default value; noise value can be modified by AV_CONF register (10h)
4. Valid at 25 °C and 1 m/s airflow
5. Default value; noise value can be modified by AV_CONF register (10h)

Table 4. Electrical characteristics

Symbol	Parameter	Test condition	Min.	Typ. ⁽¹⁾	Max.	Unit
V _{DD}	Supply voltage		1.7	–	3.6	V
I _{DD}	Supply current ⁽²⁾	1 Hz, 25 °C, 2.5 V		2		μA
I _{DDP_{DN}}	Supply current in power-down mode T = 25 °C	25 °C, 2.5 V	–	0.5	–	μA

1. Typical specifications are not guaranteed

2. Default values; see [Table 16](#)

2.1 Communication interface characteristics

2.1.1 SPI - serial peripheral interface

Subject to general operating conditions for V_{DD} and T_{OP}

Table 5. SPI slave timing values

Symbol	Parameter	Value ⁽¹⁾		Unit
		Min.	Max.	
t _{c(SPC)}	SPI clock cycle	100		ns
f _{c(SPC)}	SPI clock frequency		10	MHz
t _{su(CS)}	CS setup time	6		ns
t _{h(CS)}	CS hold time	8		
t _{su(SI)}	SDI input setup time	5		
t _{h(SI)}	SDI input hold time	15		
t _{v(SO)}	SDO valid output time		50	
t _{h(SO)}	SDO output hold time	9		
t _{dis(SO)}	SDO output disable time		50	

1. Values are guaranteed at 10 MHz clock frequency for SPI, based on characterization results, not tested in production

Figure 3. SPI slave timing diagram

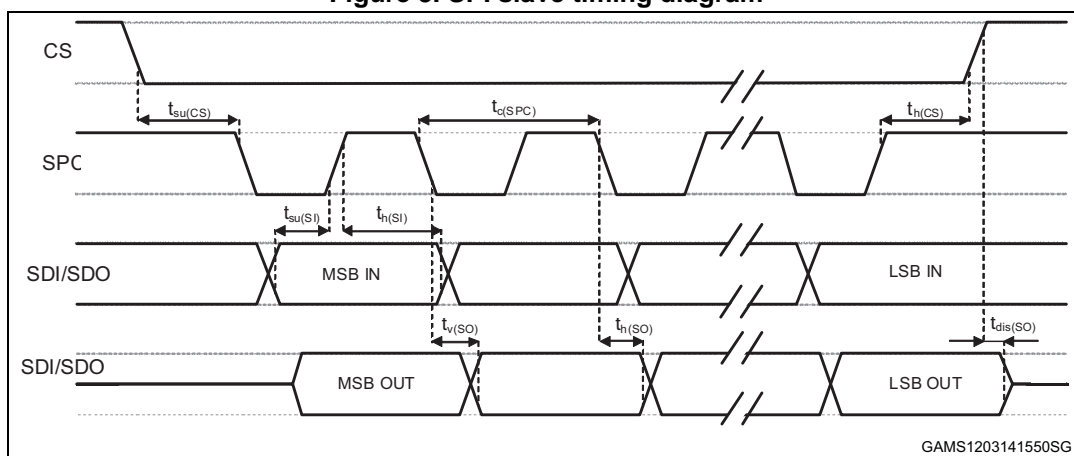

Note: Measurement points are done at $0.2 \cdot V_{DD}$ and $0.8 \cdot V_{DD}$, for both ports.

2.1.2 I²C - control interface

Subject to general operating conditions for V_{DD} and T_{OP} .

Table 6. I²C slave timing values

Symbol	Parameter (1)	I ² C standard mode (1)		I ² C fast mode (1)		Unit
		Min.	Max.	Min.	Max.	
$f_{(SCL)}$	SCL clock frequency	0	100	0	400	kHz
$t_{w(SCLL)}$	SCL clock low time	4.7		1.3		μs
$t_{w(SCLH)}$	SCL clock high time	4.0		0.6		
$t_{su(SDA)}$	SDA setup time	250		100		ns
$t_h(SDA)$	SDA data hold time	0.01	3.45	0	0.9	μs
$t_r(SDA) t_r(SCL)$	SDA and SCL rise time		1000	$20 + 0.1C_b^{(2)}$	300	ns
$t_f(SDA) t_f(SCL)$	SDA and SCL fall time		300	$20 + 0.1C_b^{(2)}$	300	
$t_h(ST)$	START condition hold time	4		0.6		μs
$t_{su}(SR)$	Repeated START condition setup time	4.7		0.6		
$t_{su}(SP)$	STOP condition setup time	4		0.6		
$t_w(SP:SR)$	Bus free time between STOP and START condition	4.7		1.3		

1. Data based on standard I²C protocol requirement, not tested in production.

2. C_b = total capacitance of one bus line, in pF

Figure 4. I²C slave timing diagram

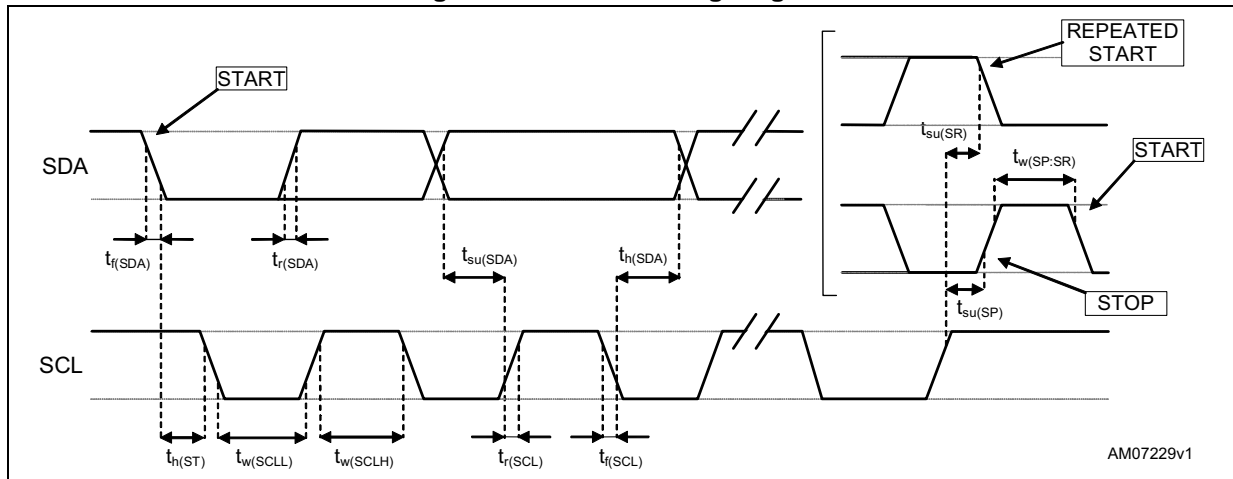

Measurement points are done at $0.2 \cdot V_{DD}$ and $0.8 \cdot V_{DD}$, for both ports.

2.2 Absolute maximum ratings

Stress above those listed as “Absolute maximum ratings” may cause permanent damage to the device. This is a stress rating only and functional operation of the device under these conditions is not implied. Exposure to maximum rating conditions for extended periods may affect device reliability.

Table 7. Absolute maximum ratings

Symbol	Ratings	Maximum value	Unit
V_{DD}	Supply voltage	-0.3 to 4.8	V
V_{IN}	Input voltage on any control pin	-0.3 to $V_{DD} + 0.3$	V
T_{STG}	Storage temperature range	-40 to +125	°C
ESD	Electrostatic discharge protection	2 (HBM)	kV

Note: Supply voltage on any pin should never exceed 4.8 V.



This is a mechanical shock sensitive device, improper handling can cause permanent damage to the part.



This is an ESD sensitive device, improper handling can cause permanent damage to the part.

3 **Functionality**

The HTS221 is a digital humidity and temperature sensor, packaged in an HLGA holed package. The device includes the sensing element and an IC (integrated circuit) interface able to take information from the sensing element and provide a digital signal to the external world, communicating through I²C/SPI interfaces with the host controller.

3.1 **IC interface**

The complete measurement chain consists of a low-noise capacitive amplifier, which converts the capacitive imbalance of the humidity sensor into an analog voltage signal, and an analog-to-digital converter is used to generate the digital information.

The converter is coupled with a dedicated hardware (HW) averaging filter to remove the high frequency component and reduce the serial interface traffic.

The relative humidity and temperature data can be accessed through an I²C/SPI interface, making the device particularly suitable for direct interfacing with a microcontroller.

3.2 **Factory calibration**

The IC (integrated circuit) interface is factory calibrated and the needed coefficients to convert the ADC 16-bit values into rH% or degrees Celsius can be read through the internal registers of the sensor. Further calibration by the user is not required.

4 Application hints

Figure 5. HTS221 electrical connection

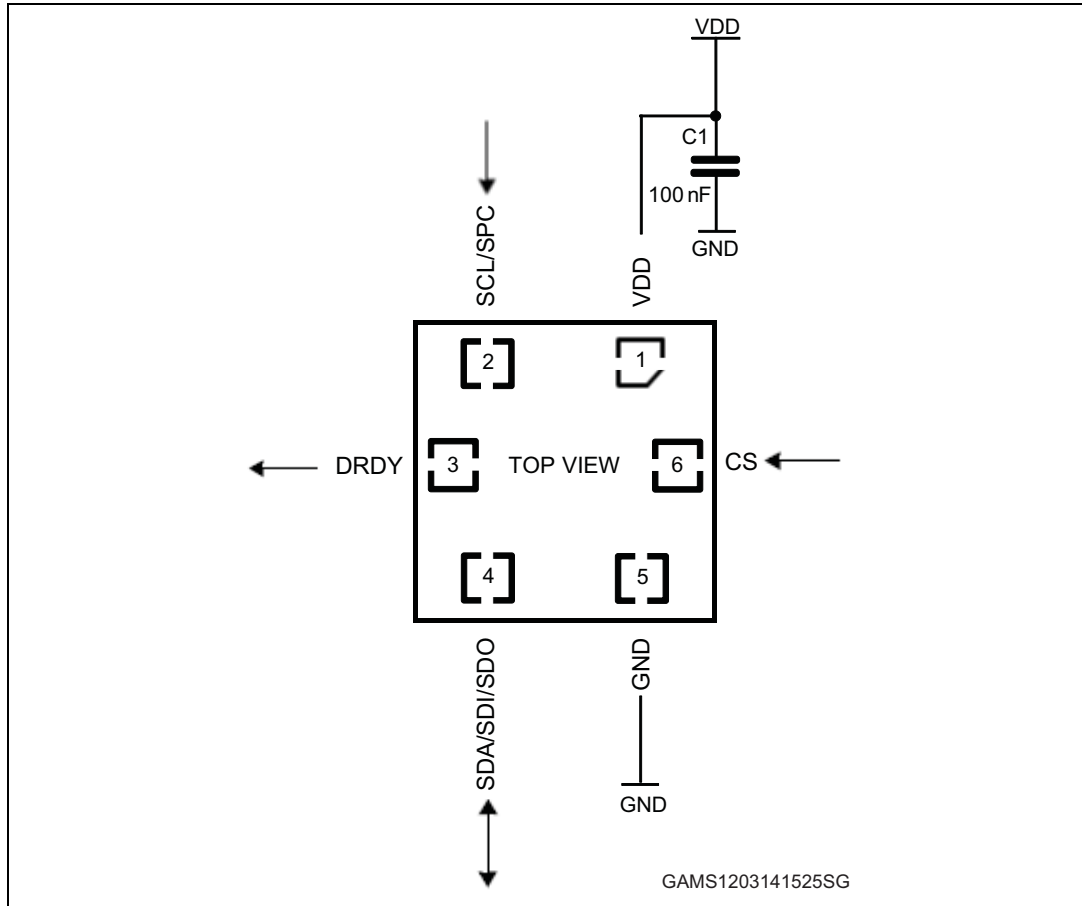

The device is supplied through the V_{DD} line. The power supply decoupling capacitor (100 nF ceramic) should be placed as near as possible to the supply pad of the device (common design practice).

The functionality of the device and the measured data outputs are selectable and accessible through the I²C/SPI interfaces.

4.1 Soldering information

The HLGA package is compliant with the ECOPACK[®] standard and it is qualified for soldering heat resistance according to JEDEC J-STD-020. After soldering, the accuracy specification of the sensor can be guaranteed after re-hydration of the sensor element in a stabilized environment (25 °C / 55% rH) for 3 days or at 70% rH for 12 h. Otherwise the sensor may read an offset that slowly disappears if exposed to ambient conditions.

5 Digital interfaces

The registers embedded in the HTS221 may be accessed through both the I²C and SPI 3-wires serial interfaces.

The serial interfaces are mapped onto the same pins. To select the I²C interface, the CS line must be tied high (i.e. connected to V_{DD}) or unconnected (internal pull-up); to select the SPI interface, the CS line must be tied low (i.e. connected to GND).

Table 8. Serial interface pin description

Pin name	Pin description
CS	I ² C/SPI mode selection 1: SPI idle mode / I ² C communication enabled 0: SPI communication mode / I ² C disabled)
SCL/SPC	I ² C serial clock (SCL) SPI serial clock (SPC)
SDA/SDI/SDO	I ² C serial data (SDA) 3-wire SPI serial data input /output (SDI/SDO)

5.1 I²C serial interface (CS = HIGH)

The HTS221 I²C is a bus slave. The I²C is employed to write data into registers whose content can also be read back.

The relevant I²C terminology is provided in [Table 9](#).

Table 9. Serial interface pin description

Term	Description
Transmitter	The device which sends data to the bus
Receiver	The device which receives data from the bus
Master	The device which initiates a transfer, generates clock signals and terminates a transfer
Slave	The device addressed by the master

There are two signals associated with the I²C bus: the serial clock line (SCL) and the serial data line (SDA). The latter is a bi-directional line used for sending and receiving the data to/from the interface. Both lines must be connected to V_{DD} through pull-up resistors.

The I²C interface is compliant with fast mode (400 kHz) I²C standards as well as with normal mode.

5.1.1 I²C operation

The transaction on the bus is started through a START (ST) signal. A start condition is defined as a HIGH to LOW transition on the data line while the SCL line is held HIGH. After this has been transmitted by the master, the bus is considered busy. The next byte of data transmitted after the start condition contains the address of the slave in the first 7 bits and the eighth bit tells whether the master is receiving data from the slave or transmitting data to the slave. When an address is sent, each device in the system compares the first seven bits after a start condition with its address. If they match, the device considers itself addressed by the master.

The 8-bit slave address (SAD) associated to the HTS221 humidity sensor is BEh (write) and BFh (read).

Data transfer with acknowledge is mandatory. The transmitter must release the SDA line during the acknowledge pulse. The receiver must then pull the data line LOW so that it remains stable low during the HIGH period of the acknowledge clock pulse. A receiver which has been addressed is obliged to generate an acknowledge after each byte of data received.

The I²C embedded in the HTS221 behaves like a slave device and the following protocol must be adhered to. After the start condition (ST) a slave address is sent, once a slave acknowledge (SAK) has been returned, a 8-bit sub-address (SUB) will be transmitted: the 7 LSB represents the actual register address while the MSB enables address auto-increment. If the MSB of the SUB field is '1', the SUB (register address) will be automatically increased to allow multiple data read/write.

The slave address is completed with a Read/Write bit. If the bit was '1' (Read), a repeated START (SR) condition must be issued after the two sub-address bytes; if the bit is '0' (Write) the master will transmit to the slave with direction unchanged. [Table 10](#) explains how the SAD + read/write bit pattern is composed, listing all the possible configurations.

Table 10. SAD + Read/Write patterns

Command	SAD[6:0]	R/W	SAD+R/W
Read	1011111	1	10111111 (BFh)
Write	1011111	0	10111110 (BEh)

Table 11. Transfer when master is writing one byte to slave

Master	ST	SAD + W		SUB		DATA		SP
Slave			SAK		SAK		SAK	

Table 12. Transfer when master is writing multiple bytes to slave

Master	ST	SAD + W		SUB		DATA		DATA		SP
Slave			SAK		SAK		SAK		SAK	

Table 13. Transfer when master is receiving (reading) one byte of data from slave

Master	ST	SAD + W		SUB		SR	SAD + R			NMAK	SP
Slave			SAK		SAK			SAK	DATA		

Table 14. Transfer when master is receiving (reading) multiple bytes of data from slave

Master	ST	SAD+W		SUB		SR	SAD+R			MAK		MAK		NMAK	SP
Slave			SAK		SAK			SAK	DATA		DATA		DATA		

Data are transmitted in byte format (DATA). Each data transfer contains 8 bits. The number of bytes transferred per transfer is unlimited. Data is transferred with the most significant bit (MSB) first. If a receiver can't receive another complete byte of data until it has performed some other functions, it can hold the clock line, SCL LOW to force the transmitter into a wait state. Data transfer only continues when the receiver is ready for another byte and releases the data line. If a slave receiver does not acknowledge the slave address (i.e. it is not able to receive because it is performing some real-time function) the data line must be kept HIGH by the slave. The master can then abort the transfer. A LOW to HIGH transition on the SDA line while the SCL line is HIGH is defined as a STOP condition. Each data transfer must be terminated by the generation of a STOP (SP) condition.

In order to read multiple bytes incrementing the register address, it is necessary to assert the most significant bit of the sub-address field. In other words, SUB(7) must be equal to 1 while SUB(6-0) represents the address of the first register to be read.

In the presented communication format MAK is master acknowledge and NMAK is no master acknowledge.

I²C high speed HS-mode devices can transfer information at bit rates of up to 3.4 Mbit/s, yet they remain fully downward compatible with fast or standard-mode (F/S-mode) devices for bi-directional communication in a mixed-speed bus system. With the exception that arbitration and clock synchronization is not performed during the HS-mode transfer, the same serial bus protocol and data format is maintained as with the F/S-mode system.

HS-mode can only begin after the following conditions (all of which are in F/S-mode):

1. START condition (S)
2. 8-bit master code (00001XXX)
3. not-acknowledge bit (A)

This master code has two main functions:

It allows arbitration and synchronization between competing masters at F/S-mode speeds, resulting in one winning master.

It indicates the beginning of an HS-mode transfer. HS-mode master codes are reserved 8-bit codes, which are not used for slave addressing or other purposes.

The master code indicates to other devices that an HS-mode transfer is to begin and the connected devices must meet the HS-mode specification. As no device is allowed to acknowledge the master code, the master code is followed by a not-acknowledge (A). After the not-acknowledge bit (A), and the SCLH line has been pulled up to a HIGH level, the active master switches to HS-mode and enables (at time t_H , see data transfer in HS mode)

the current-source pull-up circuit for the SCLH signal. As other devices can delay the serial transfer before t_{H} by stretching the LOW period of the SCLH signal, the active master will enable its current-source pull-up circuit when all devices have released the SCLH line and the SCLH signal has reached a HIGH level, thus speeding up the last part of the rise time of the SCLH signal. The active master then sends a repeated START condition (Sr) followed by a 7-bit slave address (or 10-bit slave address; see previous section) with a R/W bit address, and receives an acknowledge bit (A) from the selected slave.

After a repeated START condition and after each acknowledge bit (A) or not-acknowledge bit (A), the active master disables its current-source pull-up circuit. This enables other devices to delay the serial transfer by stretching the LOW period of the SCLH signal. The active master re-enables its current-source pull-up circuit again when all devices have released and the SCLH signal reaches a HIGH level, and so speeds up the last part of the SCLH signal's rise time. Data transfer continues in HS-mode after the next repeated START (Sr), and only switches back to F/S-mode after a STOP condition (P). To reduce the overhead of the master code, it's possible that a master links a number of HS-mode transfers, separated by repeated START conditions (Sr).

5.2 SPI bus interface (CS = LOW)

The HTS221 SPI is a slave bus that can operate in 0 and 3 SPI modes. The SPI allows to write and read the registers of the device. The serial interface interacts with the outside world through 3 wires: **CS**, **SPC**, **SDI/SDO**.

CS is the serial port enable and is controlled by the SPI master. It goes low at the start of the transmission and goes back high at the end. **SCL** is the serial port clock and it is controlled by the SPI master. It is stopped high when **CS** is high (no transmission). **SDI/SDO** is the serial port data input and output. This line is driven at the falling edge of **SCL** and should be captured at the rising edge of **SCL**.

Both the read register and write register commands are completed in 16 clock pulses or in multiples of 8 in case of multiple read/write bytes. Bit duration is the time between two falling edges of **SCL**. The first bit (bit 0) starts at the first falling edge of **SCL** after the falling edge of **CS** while the last bit (bit 15, bit 23,...) starts at the last falling edge of **SCL** just before the rising edge of **CS**.

5.2.1 SPI write

Figure 6. SPI write protocol

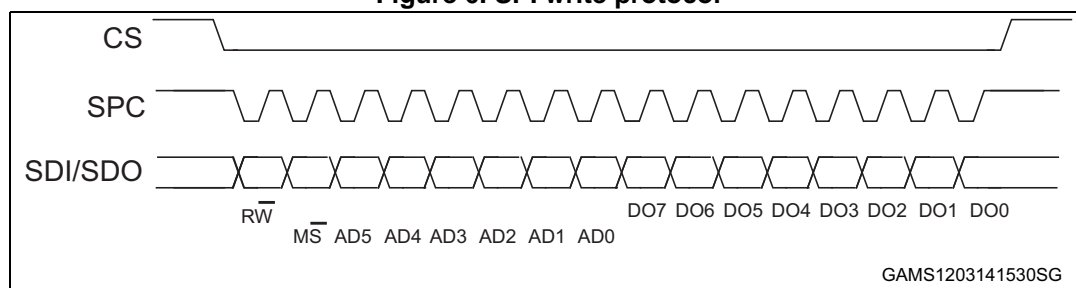

The SPI write command is performed with 16 clock pulses. A multiple byte write command is performed by adding blocks of 8 clock pulses to the previous one.

bit 0: WRITE bit. The value is 0.

bit 1: MS bit. When 0, does not increment the address; when 1, increments the address in multiple writes.

bit 2 -7: address AD(5:0). This is the address field of the indexed register.

bit 8-15: data DI(7:0) (write mode). This is the data that will be written inside the device (MSB first).

bit 16-...: data DI(...-8). Further data in multiple byte writes.

Figure 7. Multiple byte SPI write protocol (2-byte example)

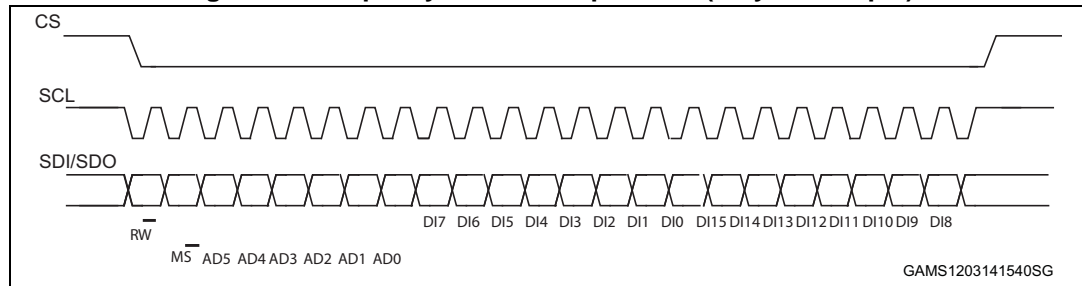

5.2.2 SPI read

Figure 8. SPI read protocol in 3-wires mode

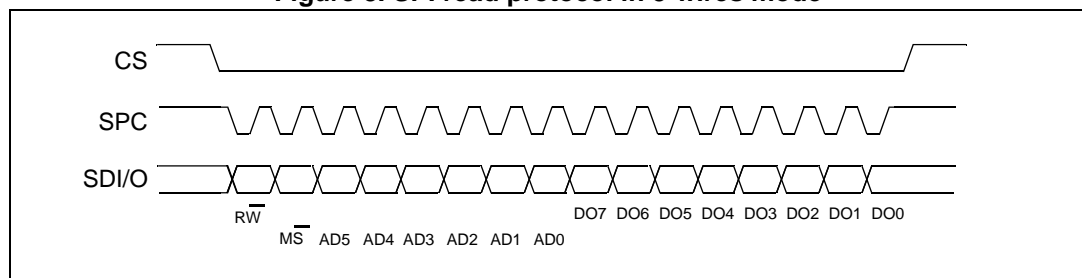

The SPI read command is performed with 16 clock pulses:

bit 0: READ bit. The value is 1.

bit 1: \overline{MS} bit. When 0, do not increment the address, when 1, increment the address in multiple readings.

bit 2-7: address AD(5:0). This is the address field of the indexed register.

bit 8-15: data DO(7:0) (read mode). This is the data that is read from the device (MSB first).

Multiple read command is also available in 3-wires mode.

6 Register mapping

The table below provides a list of the 8-bit registers embedded in the device and the related addresses.

Table 15. Register address map

Name	Type	Register address (hex)	Default (hex)
Reserved		00-0E	Do not modify
WHO_AM_I	R	0F	BC
AV_CONF	R/W	10	1B
Reserved		11-1C	Do not modify
CTRL_REG1	R/W	20	0
CTRL_REG2	R/W	21	0
CTRL_REG3	R/W	22	0
Reserved		23-26	Do not modify
STATUS_REG	R	27	0
HUMIDITY_OUT_L	R	28	Output
HUMIDITY_OUT_H	R	29	Output
TEMP_OUT_L	R	2A	Output
TEMP_OUT_H	R	2B	Output
Reserved		2C-2F	Do not modify
CALIB_0..F	R/W	30-3F	Do not modify

Registers marked as *Reserved* must not be changed. Writing to those registers may cause permanent damage to the device.

The content of the CALIB_0..F registers that are loaded at power-on from device internal non-volatile memory should never be modified.

7 Register description

The device contains a set of registers which are used to control its behavior and to retrieve humidity and temperature data. The register address, made up of 7 bits, is used to identify and to read/write the data, through the serial interfaces.

7.1 WHO_AM_I

Device identification

7	6	5	4	3	2	1	0
1	0	1	1	1	1	0	0

Address: 0Fh (R)

Description: This read-only register contains the device identifier, set to BCh

7.2 AV_CONF

Humidity and temperature resolution mode

7	6	5	4	3	2	1	0
Reserved	AVGT2	AVGT1	AVGT0	AVGH2	AVGH1	AVGH0	

Address: 10h (R/W)

Description: To configure humidity/temperature average.

[7:6] Reserved

[5:3] AVGT2-0: To select the numbers of averaged temperature samples (2 - 256), see [Table 16](#)

[2:0] AVGH2-0: To select the numbers of averaged humidity samples (4 - 512), see [Table 16](#)

Table 16. Humidity and temperature average configuration

AVGx2:0	Nr. internal average		Noise (RMS)		I _{DD} 1 Hz
	Temperature (AVGT)	Humidity (AVGH)	Temp (°C)	rH %	µA
000	2	4	0.08	0.4	0.80
001	4	8	0.05	0.3	1.05
010	8	16	0.04	0.2	1.40
011 ⁽¹⁾	16	32	0.03	0.15	2.10
100	32	64	0.02	0.1	3.43
101	64	128	0.015	0.07	6.15
110	128	256	0.01	0.05	11.60
111	256	512	0.007	0.03	22.50

1. Default configuration

7.3 CTRL_REG1

Control register 1

7	6	5	4	3	2	1	0
PD	Reserved				BDU	ODR1	ODR0

Address: 20h (R/W)

Description: Control register

- [7] PD: power down control
(0: power-down mode; 1: active mode)
- [6:3] Reserved
- [2] BDU: block data update
(0: continuous update; 1: output registers not updated until MSB and LSB reading)
- [1:0] ODR1, ODR0: output data rate selection (see table 17)

The **PD** bit is used to turn on the device. The device is in power-down mode when PD = '0' (default value after boot). The device is active when PD is set to '1'.

The **BDU** bit is used to inhibit the output register update between the reading of the upper and lower register parts. In default mode (BDU = '0'), the lower and upper register parts are updated continuously. If it is not certain whether the read will be faster than output data rate, it is recommended to set the BDU bit to '1'. In this way, after the reading of the lower (upper) register part, the content of that output register is not updated until the upper (lower) part is read also.

This feature prevents the reading of LSB and MSB related to different samples.

The ODR1 and ODR0 bits permit changes to the output data rates of humidity and temperature samples. The default value corresponds to "one shot" configuration for both humidity and temperature output. ODR1 and ODR0 can be configured as described in [Table 17](#).

Table 17. Output data rate configuration

ODR1	ODR0	Humidity (Hz)	Temperature (Hz)
0	0	One shot	
0	1	1 Hz	1 Hz
1	0	7 Hz	7 Hz
1	1	12.5 Hz	12.5 Hz

7.4 CTRL_REG2

Control register 2

7	6	5	4	3	2	1	0
BOOT	Reserved					Heater	ONE_SHOT

Address: 21h (R/W)

Description: Control register.

[7] BOOT: Reboot memory content
(0: normal mode; 1: reboot memory content)

[6:2] Reserved

[1] Heater
(0: heater disable; 1: heater enable)

[0] One shot enable
(0: waiting for start of conversion; 1: start for a new dataset)

The **BOOT** bit is used to refresh the content of the internal registers stored in the Flash memory block. At device power-up, the content of the Flash memory block is transferred to the internal registers related to trimming functions to permit good behavior of the device itself. If, for any reason, the content of the trimming registers is modified, it is sufficient to use this bit to restore the correct values. When the BOOT bit is set to '1' the content of the internal Flash is copied inside the corresponding internal registers and is used to calibrate the device. These values are factory trimmed and are different for every device. They permit good behavior of the device and normally they should not be changed. At the end of the boot process, the BOOT bit is set again to '0'.

The **ONE_SHOT** bit is used to start a new conversion. In this situation a single acquisition of temperature and humidity is started when the ONE_SHOT bit is set to '1'. At the end of conversion the new data are available in the output registers, the STATUS_REG[0] and STATUS_REG[1] bits are set to '1' and the ONE_SHOT bit comes back to '0' by hardware.

The **Heater** bit is used to control an internal heating element, that can effectively be used to speed up the sensor recovery time in case of condensation. The heater can be operated only by an external controller, which means that it has to be switched on/off directly by FW. Humidity and temperature output should not be read during the heating cycle; valid data can be read out once the heater has been turned off, after the completion of the heating cycle. Typical power consumption related to V_{DD} is described in [Table 18](#).

Table 18. Typical power consumption with heater ON

V_{DD} [V]	I [mA]
3.3	33
2.5	22
1.8	12

7.5 CTRL_REG3

Control register 3

7	6	5	4	3	2	1	0
DRDY_H_L	PP_OD	Reserved			DRDY	Reserved	

Address: 22h (R/W)

Description: Control register for data ready output signal

[7] DRDY_H_L: Data Ready output signal active high, low
(0: active high -default; 1: active low)

[6] PP_OD: Push-pull / Open Drain selection on pin 3 (DRDY)
(0: push-pull - default; 1: open drain)

[5:3] Reserved

[2] DRDY_EN: Data Ready enable

(0: Data Ready disabled - default; 1: Data Ready signal available on pin 3)

[1:0] Reserved

The **DRDY_EN** bit enables the DRDY signal on pin 3. Normally inactive, the DRDY output signal becomes active on new data available: logical OR of the bits STATUS_REG[1] and STATUS_REG[0] for humidity and temperature, respectively. The DRDY signal returns inactive after both HUMIDITY_OUT_H and TEMP_OUT_H registers are read.

7.6 STATUS_REG

Status register

7	6	5	4	3	2	1	0
Reserved						H_DA	T_DA

Address: 27h (R)

Description: Status register; the content of this register is updated every one-shot reading, and after completion of every ODR cycle, regardless of BDU value in CTRL_REG1.

[7:2] Reserved

[1] H_DA: Humidity data available.

(0: new data for Humidity is not yet available; 1: new data for Humidity is available)

[0] T_DA: Temperature data available.

(0: new data for temperature is not yet available; 1: new data for temperature is available)

H_DA is set to 1 whenever a new humidity sample is available. H_DA is cleared anytime HUMIDITY_OUT_H (29h) register is read.

T_DA is set to 1 whenever a new temperature sample is available. T_DA is cleared anytime TEMP_OUT_H (2Bh) register is read.

7.7 HUMIDITY_OUT_L

Relative humidity data (LSB)

7	6	5	4	3	2	1	0
HOUT7	HOUT6	HOUT5	HOUT4	HOUT3	HOUT2	HOUT1	HOUT0

Address: 28h (R)

Description: Humidity data (see HUMIDITY_OUT_H)

[7:0] HOUT7 - HOUT0: Humidity data LSB

7.8 HUMIDITY_OUT_H

Relative humidity data (MSB)

15	14	13	12	11	10	9	8
HOUT15	HOUT14	HOUT13	HOUT12	HOUT11	HOUT10	HOUT9	HOUT8

Address: 29h(R)

Description: Humidity data are expressed as HUMIDITY_OUT_H & HUMIDITY_OUT_L in 2's complement. Values exceeding the operating humidity range (see [Table 3](#)) must be clipped by SW.

[7:0] HOUT15 - HOUT8: Humidity data MSB

7.9 TEMP_OUT_L

Temperature data (LSB)

7	6	5	4	3	2	1	0
TOUT7	TOUT6	TOUT5	TOUT4	TOUT3	TOUT2	TOUT1	TOUT0

Address: 2Ah (R)

[7:0] TOUT7 - TOUT0: Temperature data LSB (see TEMPERATURE_OUT_H)

7.10 TEMP_OUT_H

Temperature data (MSB)

15	14	13	12	11	10	9	8
TOUT15	TOUT14	TOUT13	TOUT12	TOUT11	TOUT10	TOUT9	TOUT8

Address: 2Bh (R)

[15:8] TOUT15 - TOUT8: Temperature data MSB.

Temperature data are expressed as TEMP_OUT_H & TEMP_OUT_L as 2's complement numbers.

The relative humidity and temperature values must be computed by linear interpolation of current registers with calibration registers, according to [Table 19](#) and scaling as described in [Section 8](#).

8 Humidity and temperature data conversion

The Registers in 30h..3Fh address range contain calibration coefficients. Every sensor module has individual coefficients. Before the first calculation of temperature and humidity, the master reads out the calibration coefficients.

Table 19. Decoding the coefficients in the sensor Flash

Adr	Variable	Format	b7	b6	b5	b4	b3	b2	b1	b0
Output Registers										
28	H_OUT	(s16)	H7	H6	H5	H4	H3	H2	H1	H0
29			H15	H14	H13	H12	H11	H10	H9	H8
2A	T_OUT	(s16)	T7	T6	T5	T4	T3	T2	T1	T0
2B			T15	T14	T13	T12	T11	T10	T9	T8
Calibration Registers										
30	H0_rH_x2	(u8)	H0.7	H0.6	H0.5	H0.4	H0.3	H0.2	H0.1	H0.1
31	H1_rH_x2	(u8)	H1.7	H1.6	H1.5	H1.4	H1.3	H1.2	H1.1	H1.0
32	T0_degC_x8	(u8)	T0.7	T0.6	T0.5	T0.4	T0.3	T0.2	T0.1	T0.0
33	T1_degC_x8	(u8)	T1.7	T1.6	T1.5	T1.4	T1.3	T1.2	T1.1	T1.0
34	Reserved	(u16)								
35	T1/T0 msb	(u2),(u2)	0	0	0	0	T1.9	T1.8	T0.9	T0.8
36	H0_T0_OUT	(s16)	7	6	5	4	3	2	1	0
37			15	14	13	12	11	10	9	8
38	Reserved		7	6	5	4	3	2	1	0
39			15	14	13	12	11	10	9	8
3A	H1_T0_OUT	(s16)	7	6	5	4	3	2	1	0
3B			15	14	13	12	11	10	9	8
3C	T0_OUT	(s16)	7	6	5	4	3	2	1	0
3D			15	14	13	12	11	10	9	8
3E	T1_OUT	(s16)	7	6	5	4	3	2	1	0
3F			15	14	13	12	11	10	9	8

(u8) is the unsigned 8 bit quantity, and (s16) the signed 16 bit quantity using 2's complement format. In the example below, the two steps required to calculate temperature and relative humidity output values are described. The T0 and T1 calibration temperature values are actually composed of 10 bits (unsigned), where the 2 MSB are in reg 35h, and the 8 LSB are in regs 32h and 33h, respectively. T0 and T1 are the actual calibration temperature values multiplied by 8.

Step 1: Temperature conversion from ADC_OUT (LSB) to °C

Step 1: Linear interpolation (example)

Input Temperature LSB (ADC)	Output Temperature (DegC)
T0_OUT = 300	(T0 msb U T0_degC_x8) = 80°C => 80/8 = 10.0 °C
T_OUT = 400	T_degC_x8 =120 [interp.] =>T_degC=120/8 = 15.0 °C
T1_OUT = 500	(T0 msb U T0_degC_x8) = 160°C => 160/8 = 20.0 °C

Table 20. Step 1: Linear interpolation to convert LSB to °C

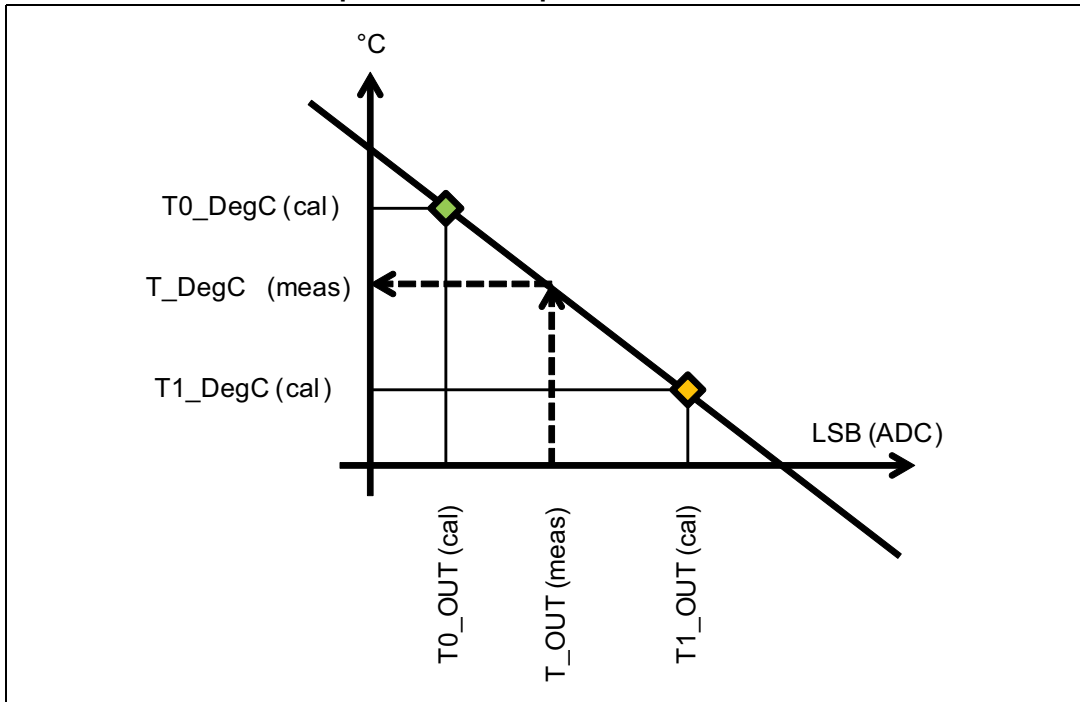

Conclusion: current temperature is 15 °C.

Step 2: Humidity conversion from ADC_OUT (LSB) to rH %

Linear interpolation for relative Humidity (example)

Input: relative Humidity LSB (ADC) Output: relative Humidity (% rH)

H0_T0_OUT = 0x4000

H0_rH_x2 = 40% rH => 40/2 = 20.0% rH

H_OUT = 0x5000

H_rH_x2 = 60% [interp.] => 60/2 = **30.0% rH**

H1_T0_OUT = 0x6000

H1_rH_x2 = 80% rH => 80/2 = 40% rH

Figure 9. Step 2: Linear interpolation to convert LSB to rH%

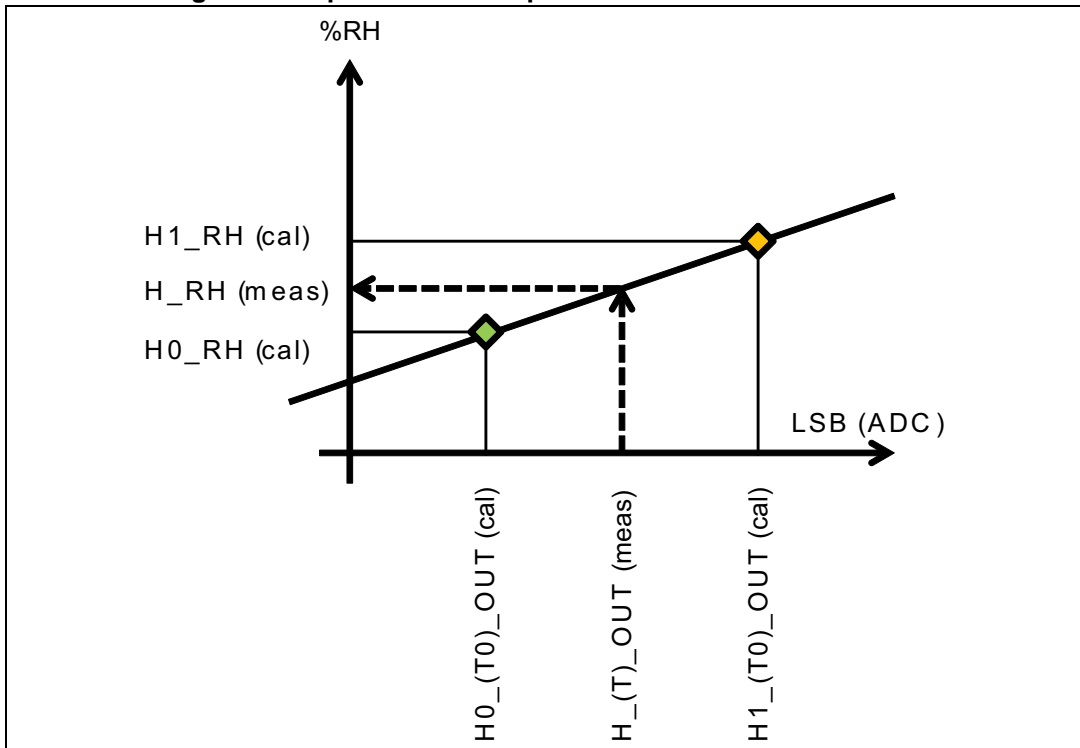

Conclusion: current relative humidity value is 30%.

9 Package mechanical section

In order to meet environmental requirements, ST offers these devices in different grades of ECOPACK[®] packages, depending on their level of environmental compliance. ECOPACK[®] specifications, grade definitions and product status are available at: www.st.com. ECOPACK is an ST trademark.

Figure 10. Package outline for HLGA-6L (2 x 2 x 0.9 mm)

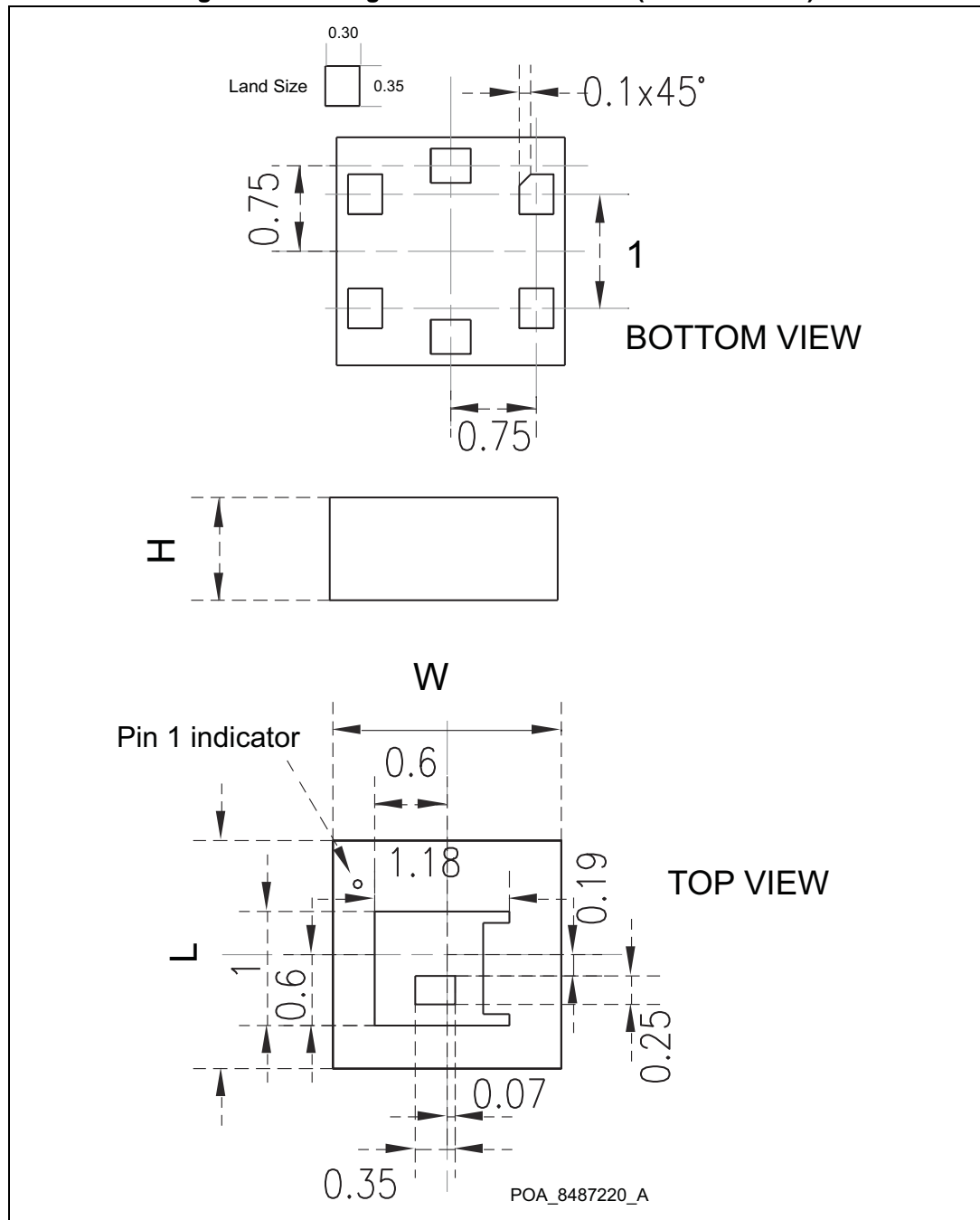

Table 21. HLGA-6L (2 x 2 x 0.9 mm) outer dimensions

Item	Dimension [mm]	Tolerance [mm]
Length [L]	2	± 0.1
Width [W]	2	± 0.1
Height [H]	0.9	± 0.1
Land Size	0.30 x 0.35	± 0.05

Dimensions are in millimeters unless otherwise specified.

General tolerance is ± 0.1 mm unless otherwise specified.

10 Revision history

Table 22. Document revision history

Date	Revision	Changes
15-May-2014	1	Initial release.

Please Read Carefully:

Information in this document is provided solely in connection with ST products. STMicroelectronics NV and its subsidiaries ("ST") reserve the right to make changes, corrections, modifications or improvements, to this document, and the products and services described herein at any time, without notice.

All ST products are sold pursuant to ST's terms and conditions of sale.

Purchasers are solely responsible for the choice, selection and use of the ST products and services described herein, and ST assumes no liability whatsoever relating to the choice, selection or use of the ST products and services described herein.

No license, express or implied, by estoppel or otherwise, to any intellectual property rights is granted under this document. If any part of this document refers to any third party products or services it shall not be deemed a license grant by ST for the use of such third party products or services, or any intellectual property contained therein or considered as a warranty covering the use in any manner whatsoever of such third party products or services or any intellectual property contained therein.

UNLESS OTHERWISE SET FORTH IN ST'S TERMS AND CONDITIONS OF SALE ST DISCLAIMS ANY EXPRESS OR IMPLIED WARRANTY WITH RESPECT TO THE USE AND/OR SALE OF ST PRODUCTS INCLUDING WITHOUT LIMITATION IMPLIED WARRANTIES OF MERCHANTABILITY, FITNESS FOR A PARTICULAR PURPOSE (AND THEIR EQUIVALENTS UNDER THE LAWS OF ANY JURISDICTION), OR INFRINGEMENT OF ANY PATENT, COPYRIGHT OR OTHER INTELLECTUAL PROPERTY RIGHT.

ST PRODUCTS ARE NOT DESIGNED OR AUTHORIZED FOR USE IN: (A) SAFETY CRITICAL APPLICATIONS SUCH AS LIFE SUPPORTING, ACTIVE IMPLANTED DEVICES OR SYSTEMS WITH PRODUCT FUNCTIONAL SAFETY REQUIREMENTS; (B) AERONAUTIC APPLICATIONS; (C) AUTOMOTIVE APPLICATIONS OR ENVIRONMENTS, AND/OR (D) AEROSPACE APPLICATIONS OR ENVIRONMENTS. WHERE ST PRODUCTS ARE NOT DESIGNED FOR SUCH USE, THE PURCHASER SHALL USE PRODUCTS AT PURCHASER'S SOLE RISK, EVEN IF ST HAS BEEN INFORMED IN WRITING OF SUCH USAGE, UNLESS A PRODUCT IS EXPRESSLY DESIGNATED BY ST AS BEING INTENDED FOR "AUTOMOTIVE, AUTOMOTIVE SAFETY OR MEDICAL" INDUSTRY DOMAINS ACCORDING TO ST PRODUCT DESIGN SPECIFICATIONS. PRODUCTS FORMALLY ESCC, QML OR JAN QUALIFIED ARE DEEMED SUITABLE FOR USE IN AEROSPACE BY THE CORRESPONDING GOVERNMENTAL AGENCY.

Resale of ST products with provisions different from the statements and/or technical features set forth in this document shall immediately void any warranty granted by ST for the ST product or service described herein and shall not create or extend in any manner whatsoever, any liability of ST.

ST and the ST logo are trademarks or registered trademarks of ST in various countries.

Information in this document supersedes and replaces all information previously supplied.

The ST logo is a registered trademark of STMicroelectronics. All other names are the property of their respective owners.

© 2014 STMicroelectronics - All rights reserved

STMicroelectronics group of companies

Australia - Belgium - Brazil - Canada - China - Czech Republic - Finland - France - Germany - Hong Kong - India - Israel - Italy - Japan - Malaysia - Malta - Morocco - Philippines - Singapore - Spain - Sweden - Switzerland - United Kingdom - United States of America

www.st.com



LittleDiode supplies new, hard to find or obsolete electronic components and semiconductors all over the world.

With over two million different components listed you are sure to find the part you need.

Feel free to visit us today at our online store:

LittleDiode.com

Looking forward to providing you with the best possible service.