

256K (32K x 8) Static RAM

Features

- **Temperature Ranges**
 - Commercial: 0°C to 70°C
 - Industrial: -40°C to 85°C
 - Automotive: -40°C to 125°C
- **High speed: 55 ns and 70 ns**
- **Voltage range: 4.5V–5.5V operation**
- **Low active power (70 ns, LL version, Com'I and Ind'I)**
 - 275 mW (max.)
- **Low standby power (70 ns, LL version, Com'I and Ind'I)**
 - 28 μW (max.)
- **Easy memory expansion with \overline{CE} and \overline{OE} features**
- **TTL-compatible inputs and outputs**
- **Automatic power-down when deselected**
- **CMOS for optimum speed/power**
- **Package available in a standard 450-mil-wide (300-mil body width) 28-lead narrow SOIC, 28-lead TSOP-1, 28-lead reverse TSOP-1, and 600-mil 28-lead PDIP packages**

Functional Description^[1]

The CY62256 is a high-performance CMOS static RAM organized as 32K words by 8 bits. Easy memory expansion is provided by an active LOW chip enable (\overline{CE}) and active LOW output enable (\overline{OE}) and three-state drivers. This device has an automatic power-down feature, reducing the power consumption by 99.9% when deselected.

An active LOW write enable signal (\overline{WE}) controls the writing/reading operation of the memory. When \overline{CE} and \overline{WE} inputs are both LOW, data on the eight data input/output pins (I/O_0 through I/O_7) is written into the memory location addressed by the address present on the address pins (A_0 through A_{14}). Reading the device is accomplished by selecting the device and enabling the outputs, \overline{CE} and \overline{OE} active LOW, while \overline{WE} remains inactive or HIGH. Under these conditions, the contents of the location addressed by the information on address pins are present on the eight data input/output pins.

The input/output pins remain in a high-impedance state unless the chip is selected, outputs are enabled, and write enable (\overline{WE}) is HIGH.

Logic Block Diagram

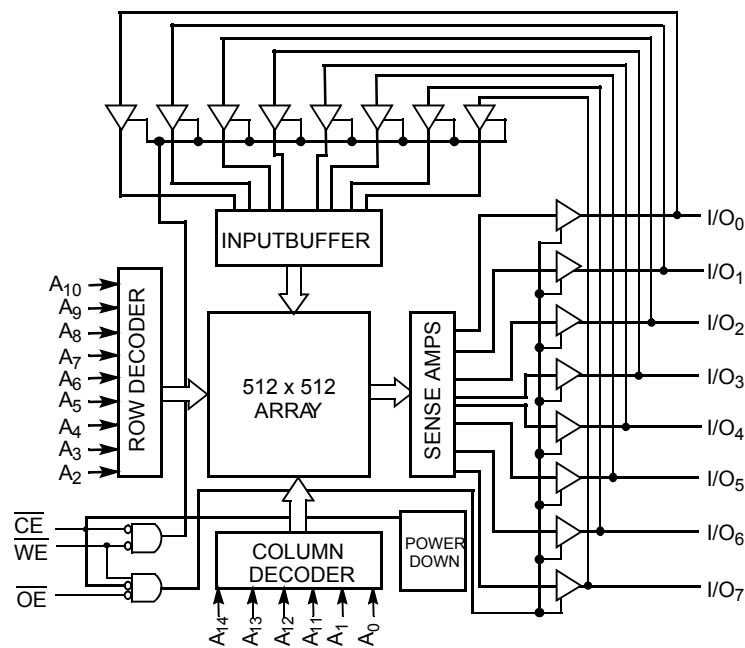

Note:

1. For best practice recommendations, please refer to the Cypress application note "System Design Guidelines" on <http://www.cypress.com>.

Product Portfolio

Product		V _{CC} Range (V)			Speed (ns)	Power Dissipation			
						Operating, I _{CC} (mA)		Standby, I _{SB2} (μA)	
		Min.	Typ. ^[2]	Max.		Typ. ^[2]	Max.	Typ. ^[2]	Max.
CY62256	Commercial	4.5	5.0	5.5	70	28	55	1	5
CY62256L	Com'l / Ind'l				55/70	25	50	2	50
CY62256LL	Commercial				70	25	50	0.1	5
CY62256LL	Industrial				55/70	25	50	0.1	10
CY62256LL	Automotive				55	25	50	0.1	15

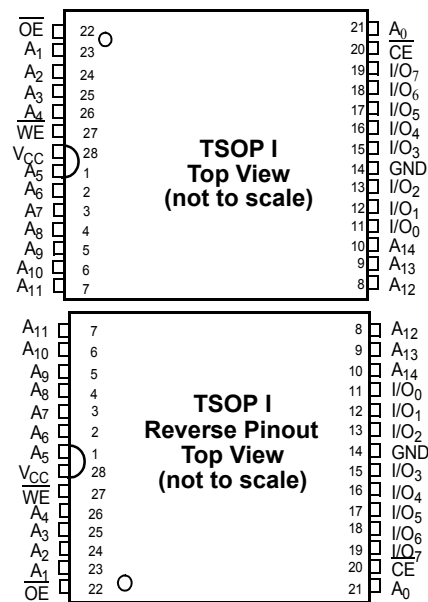
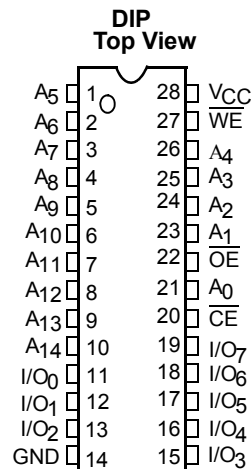
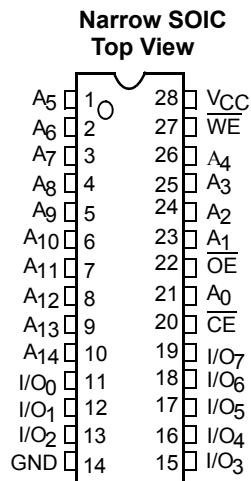
Pin Configurations

Pin Definitions

Pin Number	Type	Description
1-10, 21, 23-26	Input	A ₀ -A ₁₄ . Address Inputs
11-13, 15-19,	Input/Output	I/O ₀ -I/O ₇ . Data lines. Used as input or output lines depending on operation
27	Input/Control	WE. When selected LOW, a WRITE is conducted. When selected HIGH, a READ is conducted
20	Input/Control	CE. When LOW, selects the chip. When HIGH, deselects the chip
22	Input/Control	OE. Output Enable. Controls the direction of the I/O pins. When LOW, the I/O pins behave as outputs. When deasserted HIGH, I/O pins are three-stated, and act as input data pins
14	Ground	GND. Ground for the device
28	Power Supply	V _{CC} . Power supply for the device

Notes:

- Typical specifications are the mean values measured over a large sample size across normal production process variations and are taken at nominal conditions (T_A = 25°C, V_{CC}). Parameters are guaranteed by design and characterization, and not 100% tested.

Maximum Ratings

(Above which the useful life may be impaired. For user guidelines, not tested.)

Storage Temperature -65°C to +150°C
 Ambient Temperature with Power Applied..... -55°C to +125°C
 Supply Voltage to Ground Potential (Pin 28 to Pin 14) -0.5V to +7.0V
 DC Voltage Applied to Outputs in High-Z State^[3] -0.5V to V_{CC} + 0.5V
 DC Input Voltage^[3] -0.5V to V_{CC} + 0.5V

Output Current into Outputs (LOW)..... 20 mA
 Static Discharge Voltage..... > 2001V (per MIL-STD-883, Method 3015)
 Latch-up Current..... > 200 mA

Operating Range

Range	Ambient Temperature (T _A) ^[4]	V _{CC}
Commercial	0°C to +70°C	5V ± 10%
Industrial	-40°C to +85°C	5V ± 10%
Automotive	-40°C to +125°C	5V ± 10%

Electrical Characteristics Over the Operating Range

Parameter	Description	Test Conditions	CY62256-55			CY62256-70			Unit
			Min.	Typ. ^[2]	Max.	Min.	Typ. ^[2]	Max.	
V _{OH}	Output HIGH Voltage	V _{CC} = Min., I _{OH} = -1.0 mA	2.4			2.4			V
V _{OL}	Output LOW Voltage	V _{CC} = Min., I _{OL} = 2.1 mA			0.4			0.4	V
V _{IH}	Input HIGH Voltage		2.2		V _{CC} + 0.5V	2.2		V _{CC} + 0.5V	V
V _{IL}	Input LOW Voltage		-0.5		0.8	-0.5		0.8	V
I _{IX}	Input Leakage Current	GND ≤ V _I ≤ V _{CC}	-0.5		+0.5	-0.5		+0.5	μA
I _{OZ}	Output Leakage Current	GND ≤ V _O ≤ V _{CC} , Output Disabled	-0.5		+0.5	-0.5		+0.5	μA
I _{CC}	V _{CC} Operating Supply Current	V _{CC} = Max., I _{OUT} = 0 mA, f = f _{MAX} = 1/t _{RC}		28	55	28	55	mA	
			L	25	50	25	50	mA	
			LL	25	50	25	50	mA	
I _{SB1}	Automatic CE Power-down Current—TTL Inputs	Max. V _{CC} , CE ≥ V _{IH} , V _{IN} ≥ V _{IH} or V _{IN} ≤ V _{IL} , f = f _{MAX}		0.5	2	0.5	2	mA	
			L	0.4	0.6	0.4	0.6	mA	
			LL	0.3	0.5	0.3	0.5	mA	
I _{SB2}	Automatic CE Power-down Current—CMOS Inputs	Max. V _{CC} , CE ≥ V _{CC} - 0.3V, V _{IN} ≥ V _{CC} - 0.3V, or V _{IN} ≤ 0.3V, f = 0		1	5	1	5	mA	
			L	2	50	2	50	μA	
			LL	0.1	5	0.1	5	μA	
			LL - Ind'l	0.1	10	0.1	10	μA	
			LL - Auto	0.1	15			μA	

Capacitance^[5]

Parameter	Description	Test Conditions	Max.	Unit
C _{IN}	Input Capacitance	T _A = 25°C, f = 1 MHz, V _{CC} = 5.0V	6	pF
C _{OUT}	Output Capacitance		8	pF

Notes:

- V_{IL} (min.) = -2.0V for pulse durations of less than 20 ns.
- T_A is the "Instant-On" case temperature.
- Tested initially and after any design or process changes that may affect these parameters.

Thermal Resistance

Description	Test Conditions	Symbol	DIP	SOIC	TSOP	RTSOP	Unit
Thermal Resistance (Junction to Ambient) ^[5]	Still Air, soldered on a 4.25 x 1.125 inch, 4-layer printed circuit board	Θ_{JA}	75.61	76.56	93.89	93.89	°C/W
Thermal Resistance (Junction to Case) ^[5]		Θ_{JC}	43.12	36.07	24.64	24.64	°C/W

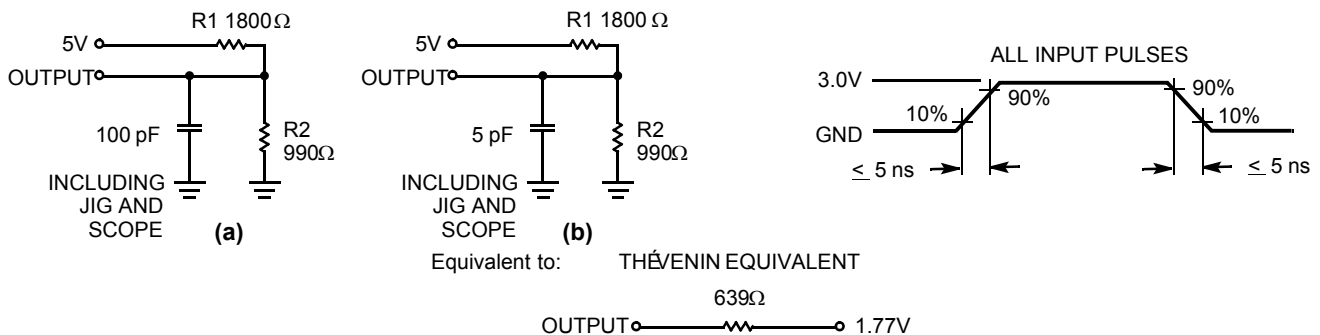
AC Test Loads and Waveforms

Data Retention Characteristics

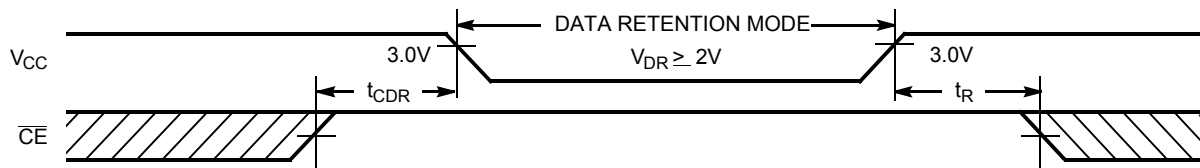
Parameter	Description	Conditions ^[6]	Min.	Typ. ^[2]	Max.	Unit
V_{DR}	V_{CC} for Data Retention		2.0			V
I_{CCDR}	Data Retention Current	L	$V_{CC} = 3.0V, CE \geq V_{CC} - 0.3V,$ $V_{IN} \geq V_{CC} - 0.3V, \text{ or } V_{IN} \leq 0.3V$	2	50	μA
		LL		0.1	5	μA
		LL - Ind'l		0.1	10	μA
		LL - Auto		0.1	10	μA
$t_{CDR}^{[5]}$	Chip Deselect to Data Retention Time		0			ns
$t_R^{[5]}$	Operation Recovery Time		t_{RC}			ns

Data Retention Waveform

Notes:

6. No input may exceed $V_{CC} + 0.5V$.

Switching Characteristics Over the Operating Range^[7]

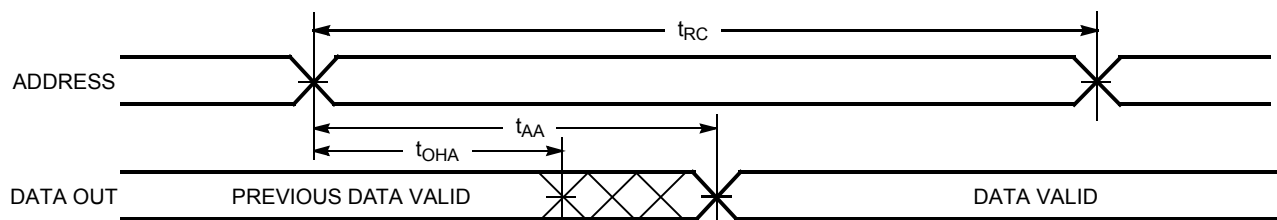
Parameter	Description	CY62256-55		CY62256-70		Unit
		Min.	Max.	Min.	Max.	
Read Cycle						
t_{RC}	Read Cycle Time	55		70		ns
t_{AA}	Address to Data Valid		55		70	ns
t_{OHA}	Data Hold from Address Change	5		5		ns
t_{ACE}	CE LOW to Data Valid		55		70	ns
t_{DOE}	OE LOW to Data Valid		25		35	ns
t_{LZOE}	OE LOW to Low-Z ^[8]	5		5		ns
t_{HZOE}	OE HIGH to High-Z ^[8, 9]		20		25	ns
t_{LZCE}	CE LOW to Low-Z ^[8]	5		5		ns
t_{HZCE}	CE HIGH to High-Z ^[8, 9]		20		25	ns
t_{PU}	CE LOW to Power-up	0		0		ns
t_{PD}	CE HIGH to Power-down		55		70	ns
Write Cycle^[10, 11]						
t_{WC}	Write Cycle Time	55		70		ns
t_{SCE}	CE LOW to Write End	45		60		ns
t_{AW}	Address Set-up to Write End	45		60		ns
t_{HA}	Address Hold from Write End	0		0		ns
t_{SA}	Address Set-up to Write Start	0		0		ns
t_{PWE}	WE Pulse Width	40		50		ns
t_{SD}	Data Set-up to Write End	25		30		ns
t_{HD}	Data Hold from Write End	0		0		ns
t_{HZWE}	WE LOW to High-Z ^[8, 9]		20		25	ns
t_{LZWE}	WE HIGH to Low-Z ^[8]	5		5		ns

Switching Waveforms
Read Cycle No. 1^[12, 13]

Notes:

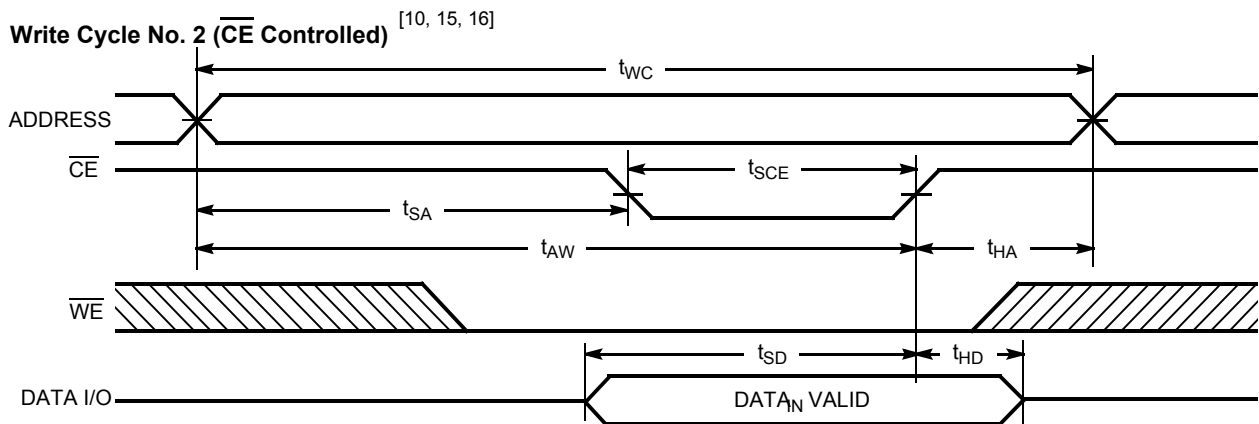
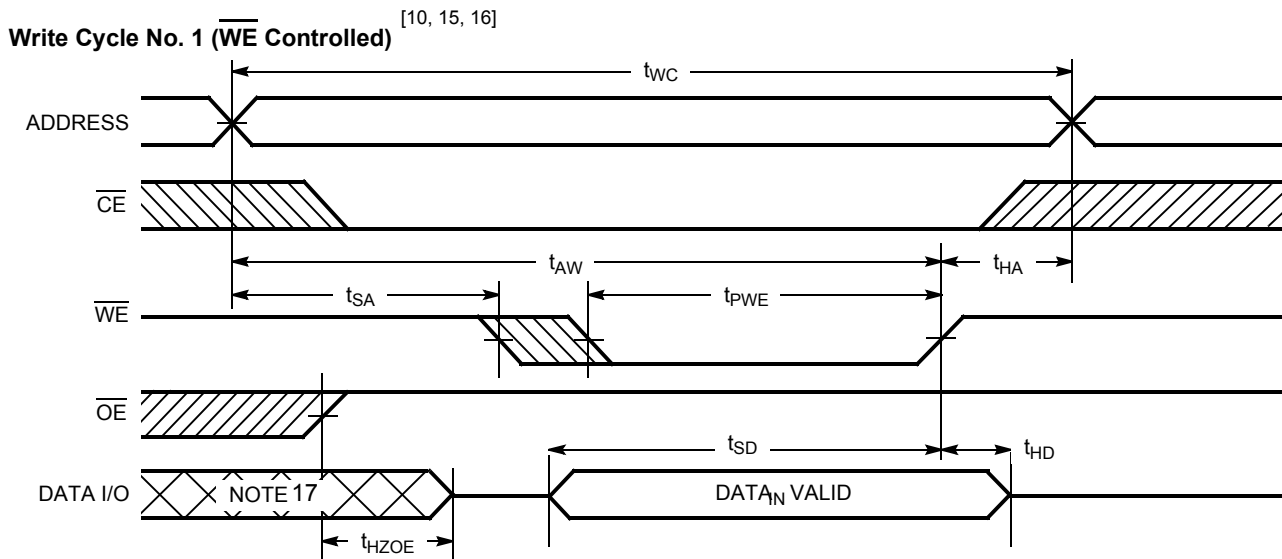
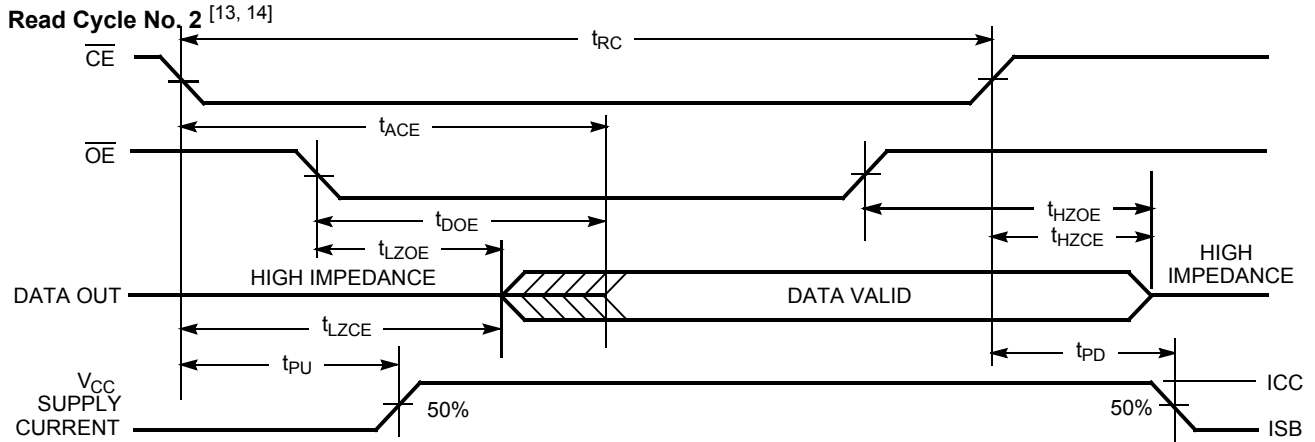
7. Test conditions assume signal transition time of 5 ns or less, timing reference levels of 1.5V, input pulse levels of 0 to 3.0V, and output loading of the specified I_{OL}/I_{OH} and 100-pF load capacitance.
8. At any given temperature and voltage condition, t_{HZCE} is less than t_{LZCE} , t_{HZOE} is less than t_{LZOE} , and t_{HZWE} is less than t_{LZWE} for any given device.
9. t_{HZOE} , t_{HZCE} , and t_{HZWE} are specified with $C_L = 5$ pF as in (b) of AC Test Loads. Transition is measured ± 500 mV from steady-state voltage.
10. The internal Write time of the memory is defined by the overlap of CE LOW and WE LOW. Both signals must be LOW to initiate a Write and either signal can terminate a Write by going HIGH. The data input set-up and hold timing should be referenced to the rising edge of the signal that terminates the Write.
11. The minimum Write cycle time for Write cycle #3 (WE controlled, OE LOW) is the sum of t_{HZWE} and t_{SD} .
12. Device is continuously selected. \overline{OE} , $\overline{CE} = V_{IL}$.
13. WE is HIGH for Read cycle.

Switching Waveforms (continued)

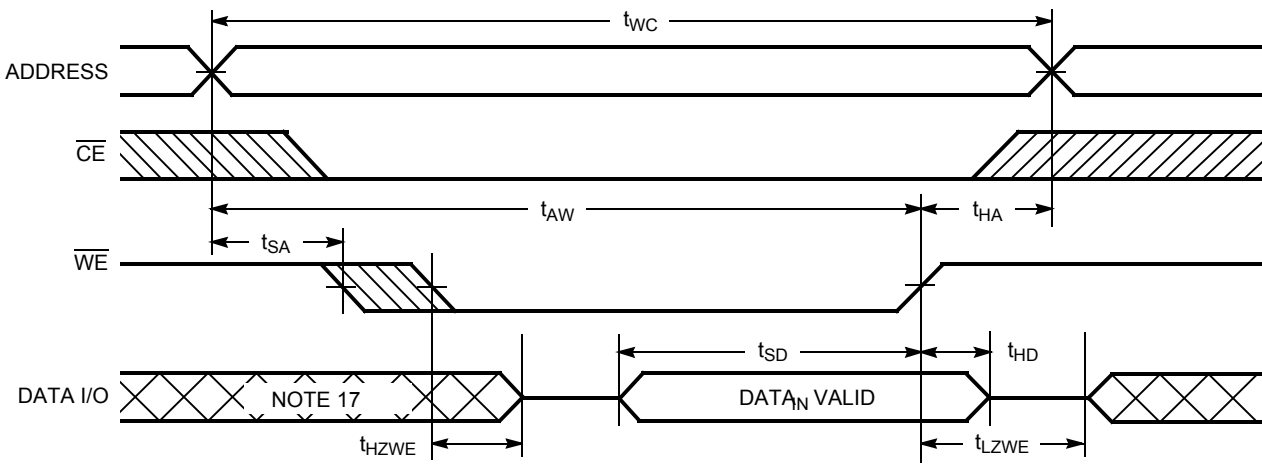
Notes:

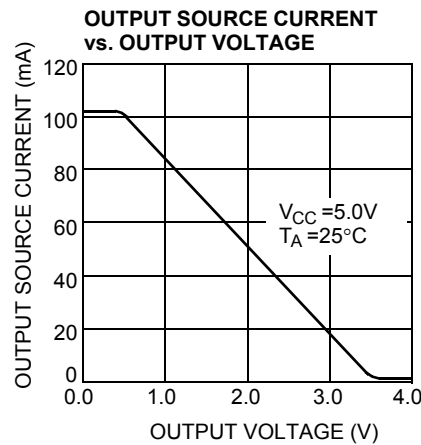
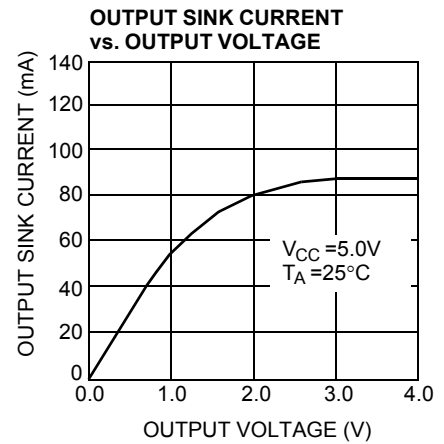
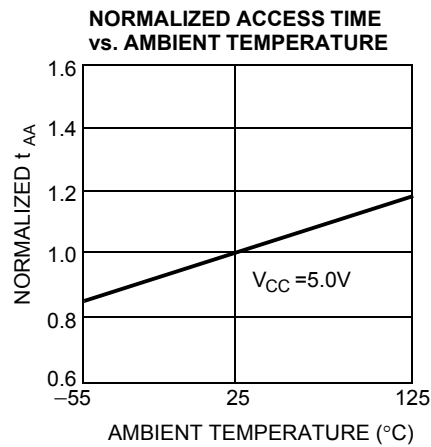
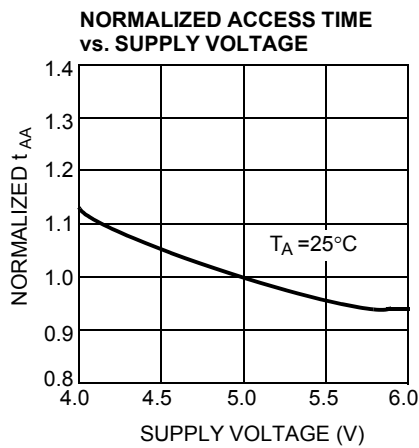
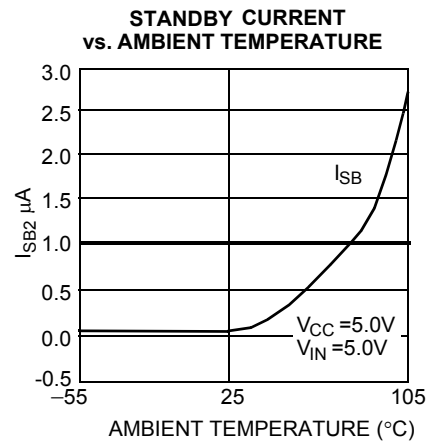
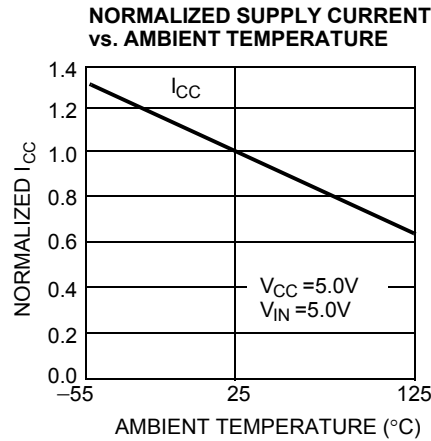
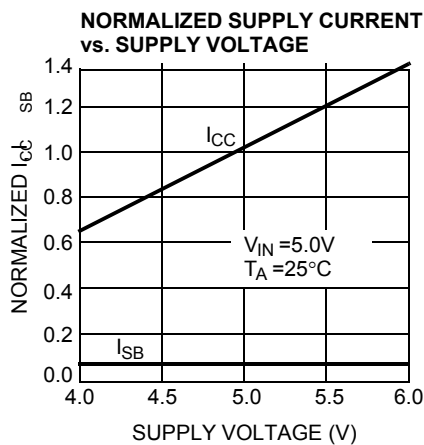
14. Address valid prior to or coincident with \overline{CE} transition LOW.
15. Data I/O is high impedance if $OE = V_{IH}$.
16. If \overline{CE} goes HIGH simultaneously with WE HIGH, the output remains in a high-impedance state.
17. During this period, the I/Os are in output state and input signals should not be applied.

Switching Waveforms (continued)
Write Cycle No. 3 (\overline{WE} Controlled, \overline{OE} LOW) [11, 16]

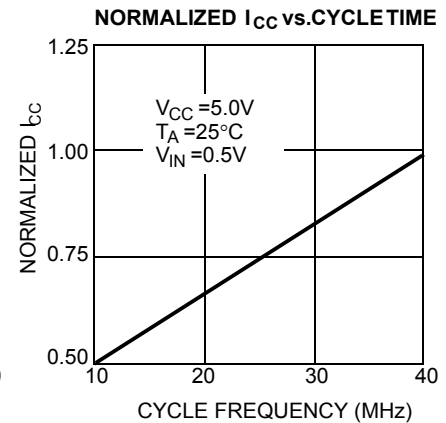
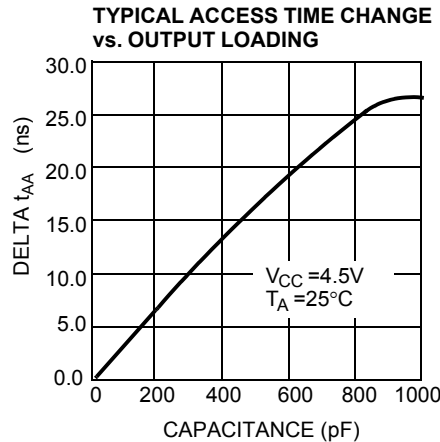
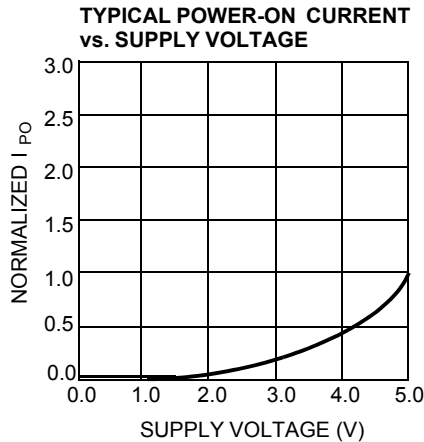
Typical DC and AC Characteristics

Typical DC and AC Characteristics (continued)

Truth Table

CE	WE	OE	Inputs/Outputs	Mode	Power
H	X	X	High-Z	Deselect/Power-down	Standby (I_{SB})
L	H	L	Data Out	Read	Active (I_{CC})
L	L	X	Data In	Write	Active (I_{CC})
L	H	H	High-Z	Output Disabled	Active (I_{CC})

Ordering Information

Speed (ns)	Ordering Code	Package Name	Package Type	Operating Range
55	CY62256LL-55SNI	SN28	28-lead (300-Mil Narrow Body) Narrow SOIC	Industrial
	CY62256LL-55ZI	Z28	28-lead Thin Small Outline Package	
	CY62256LL-55SNE	SN28	28-lead (300-Mil Narrow Body) Narrow SOIC	Automotive
	CY62256LL-55ZE	Z28	28-lead Thin Small Outline Package	
	CY62256LL-55ZRE	ZR28	28-lead Reverse Thin Small Outline Package	
70	CY62256-70SNC	SN28	28-lead (300-Mil Narrow Body) Narrow SOIC	Commercial
	CY62256L-70SNC			
	CY62256LL-70SNC			
	CY62256L-70SNI			Industrial
	CY62256LL-70SNI			
	CY62256LL-70ZC	Z28	28-lead Thin Small Outline Package	Commercial
	CY62256LL-70ZI	Z28		Industrial
	CY62256-70PC	P15	28-lead (600-Mil) Molded DIP	Commercial
	CY62256L-70PC			
	CY62256LL-70PC			
CY62256LL-70ZRI	ZR28	28-lead Reverse Thin Small Outline Package	Industrial	

Package Diagrams

28-lead (600-mil) Molded DIP P15

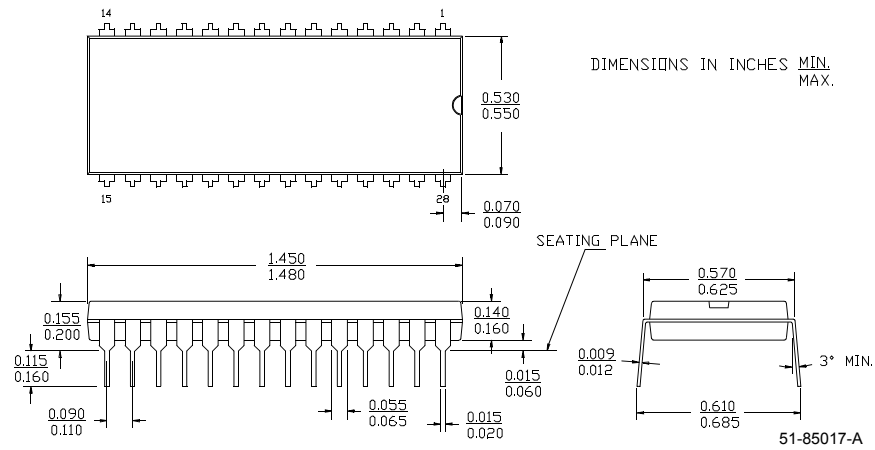

28-lead (300-mil) SNC (Narrow Body) SN28

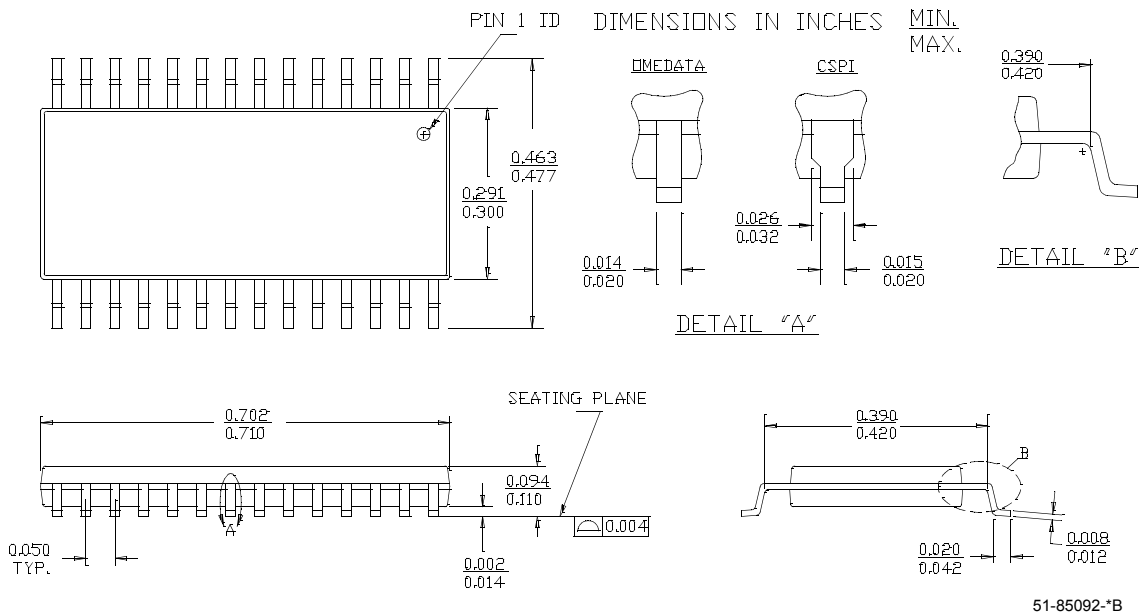

Package Diagrams (continued)
28-lead Thin Small Outline Package Type 1 (8 x 13.4 mm) Z28

NOTE: ORIENTATION I.D. MAY BE LOCATED EITHER AS SHOWN IN OPTION 1 OR OPTION 2

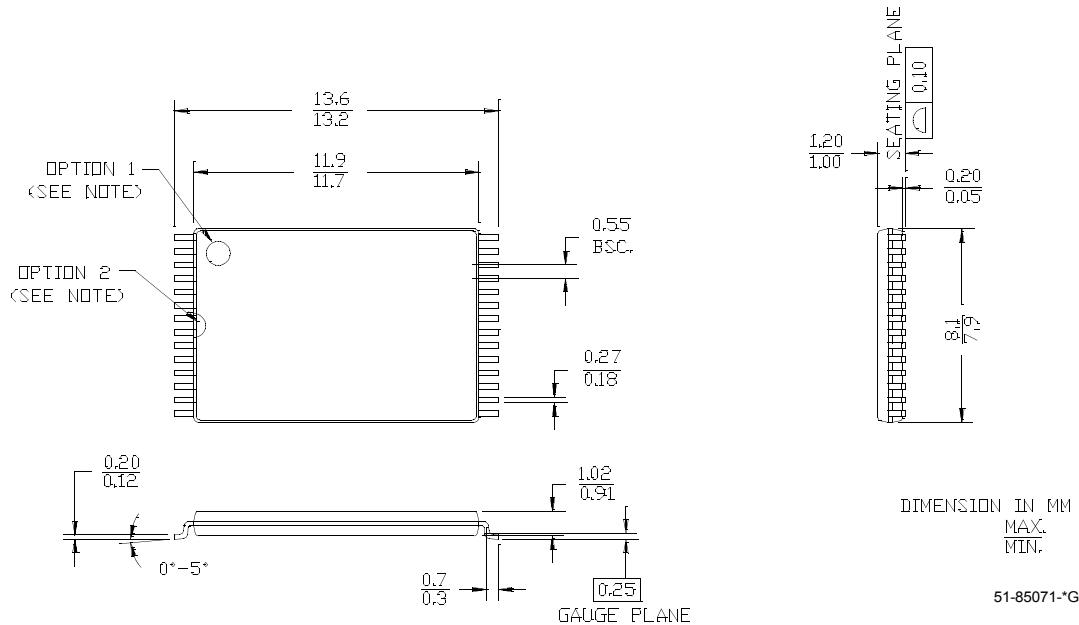
28-lead Reverse Type 1 Thin Small Outline Package (8 x 13.4 mm) ZR28

NOTE: ORIENTATION I.D. MAY BE LOCATED EITHER AS SHOWN IN OPTION 1 OR OPTION 2

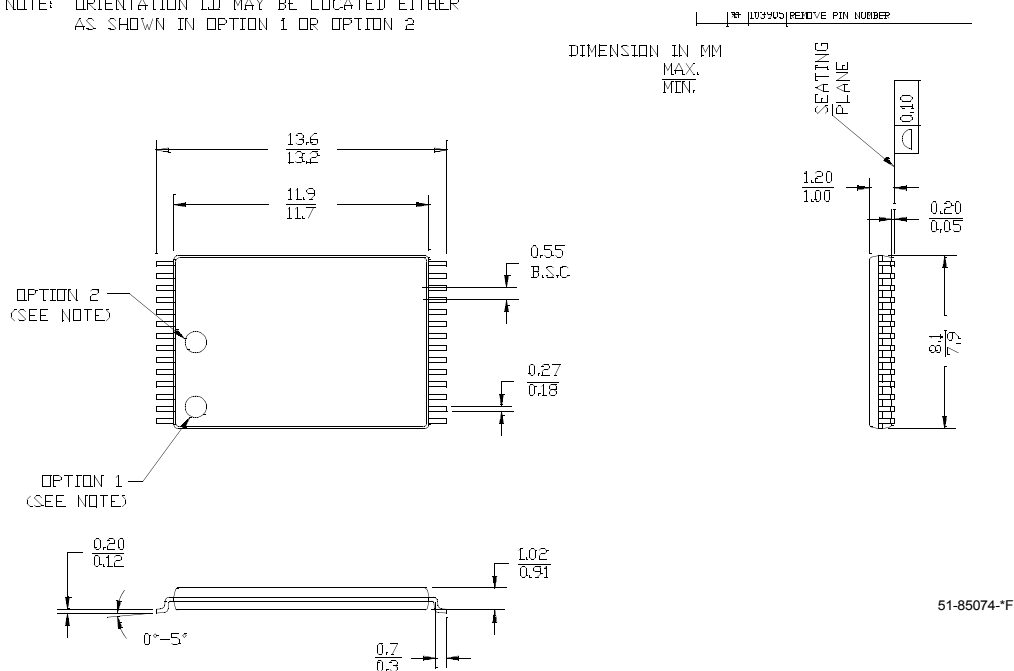

All product and company names mentioned in this document are the trademarks of their respective holders.

Document Title: CY62256 256K (32K x 8) Static RAM
Document Number: 38-05248

REV.	ECN NO.	Issue Date	Orig. of Change	Description of Change
**	113454	03/06/02	MGN	Change from Spec number: 38-00455 to 38-05248 Remove obsolete parts from ordering info, standardize format
*A	115227	05/23/02	GBI	Changed SN Package Diagram
*B	116506	09/04/02	GBI	Added footnote 1. Corrected package description in Ordering Information table
*C	238448	See ECN	AJU	Added Automotive product information



LittleDiode supplies new, hard to find or obsolete electronic components and semiconductors all over the world.

With over two million different components listed you are sure to find the part you need.

Feel free to visit us today at our online store:

LittleDiode.com

Looking forward to providing you with the best possible service.