

### Typical Applications

Prescaler for DC to X Band PLL Applications:

- Satellite Communication Systems
- Fiber Optic
- Pt-Pt and Pt-MPt Radios
- VSAT

### Features

- Ultra Low SSB Phase Noise: -149 dBc/Hz
- Wide Bandwidth
- Output Power: -6 dBm
- Single DC Supply: +5V
- Small Size: 0.686 mm x 1.295 mm

### Functional Diagram

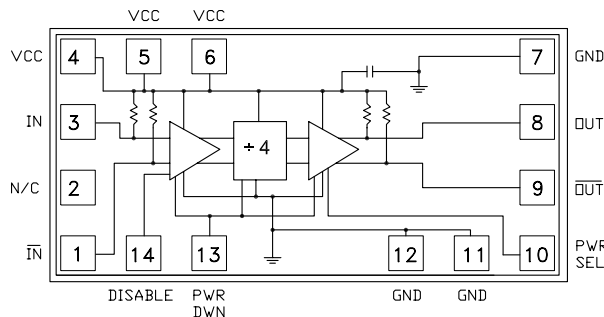

### General Description

The HMC362 is a low noise Divide-by-4 Static Divider with InGaP GaAs HBT technology that has a small size of 0.686 mm x 1.295 mm. This device operates from DC (with a square wave input) to 11 GHz input frequency with a single +5.0V DC supply. The low additive SSB phase noise of -149 dBc/Hz at 100 kHz offset helps the user maintain good system noise performance.

### Electrical Specifications, $T_A = +25^\circ C$ , 50 Ohm System, $V_{cc} = 5V$

| Parameter                        | Conditions                            | Min. | Typ. | Max. | Units  |
|----------------------------------|---------------------------------------|------|------|------|--------|
| Maximum Input Frequency          |                                       | 11   | 12   |      | GHz    |
| Minimum Input Frequency          | Sine Wave Input. [1]                  |      | 0.2  | 0.5  | GHz    |
| Input Power Range                | $F_{in} = 1$ to 8 GHz                 | -15  | >-20 | +10  | dBm    |
|                                  | $F_{in} = 8$ to 11 GHz                | -10  | >-15 | +2   | dBm    |
| Output Power [2]                 | $F_{in} = 11$ GHz                     | -9   | -6   |      | dBm    |
| Reverse Leakage                  | Both RF Outputs Terminated            |      | 40   |      | dB     |
| SSB Phase Noise (100 kHz offset) | $P_{in} = 0$ dBm, $F_{in} = 6$ GHz    |      | -149 |      | dBc/Hz |
| Output Transition Time           | $P_{in} = 0$ dBm, $F_{out} = 882$ MHz |      | 100  |      | ps     |
| Supply Current ( $I_{cc}$ ) [2]  |                                       |      | 68   |      | mA     |

1. Divider will operate down to DC for square-wave input signal.
2. When operated in low power mode (pin 10 floating).

## GaAs HBT MMIC DIVIDE-BY-4, DC - 11.0 GHz

**Input Sensitivity Window,  $T= 25\text{ }^{\circ}\text{C}$**

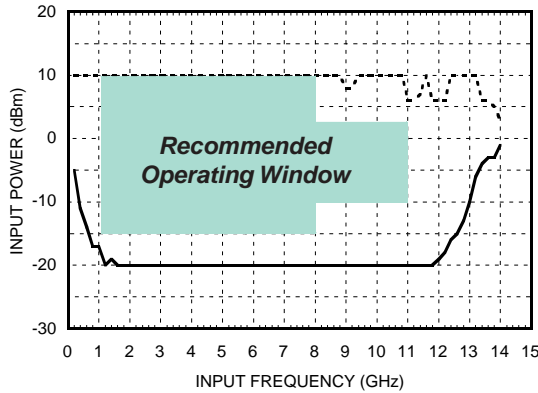

**Input Sensitivity Window vs. Temperature**

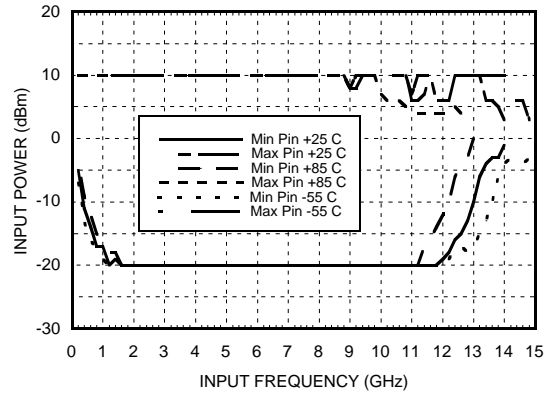

**Output Power vs. Temperature**

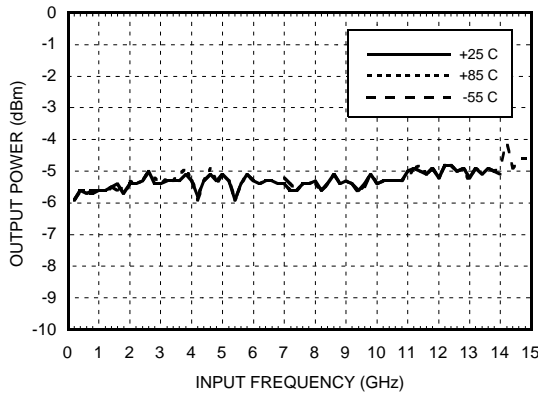

**SSB Phase Noise**

**Performance,  $P_{in}= 0\text{ dBm}$ ,  $T= 25\text{ }^{\circ}\text{C}$**

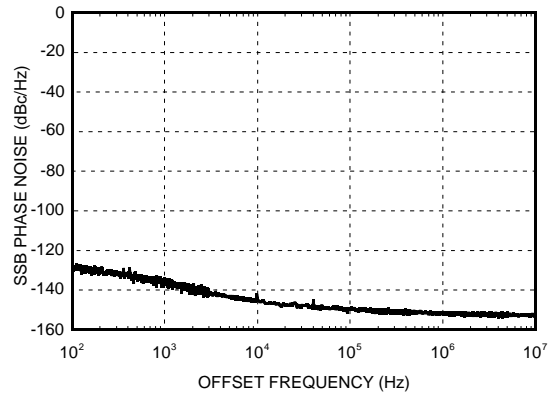

**Output Harmonic**

**Content,  $P_{in}= 0\text{ dBm}$ ,  $T= 25\text{ }^{\circ}\text{C}$**

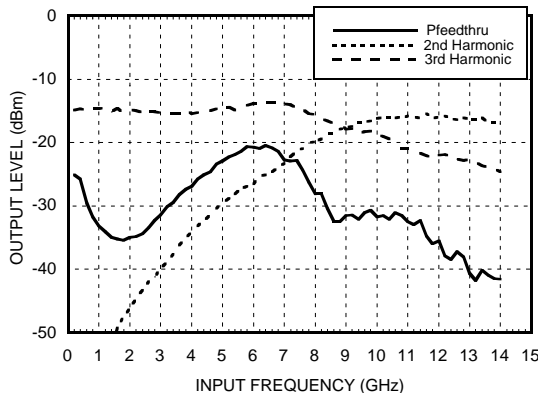

**Reverse Leakage,  $P_{in}= 0\text{ dBm}$ ,  $T= 25\text{ }^{\circ}\text{C}$**

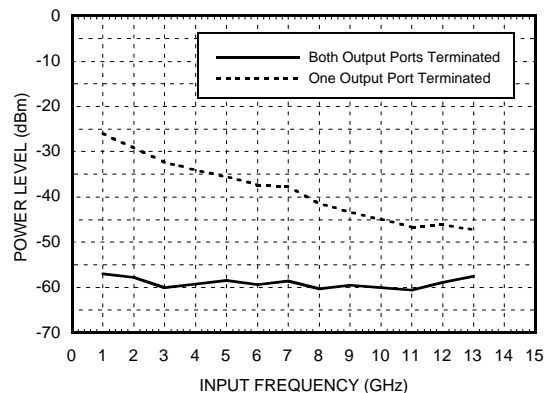

## GaAs HBT MMIC DIVIDE-BY-4, DC - 11.0 GHz

**Output Voltage Waveform,**  
*Pin= 0 dBm, Fout= 882 MHz, T= 25 °C*

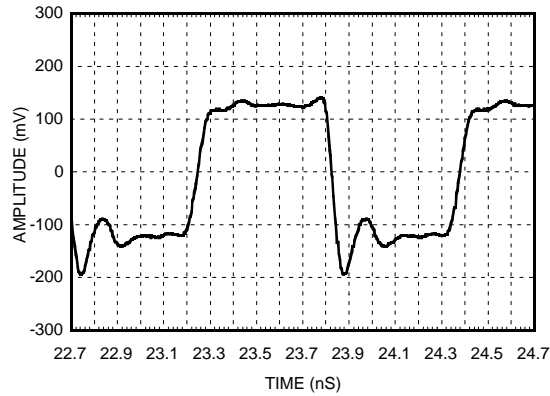

### Absolute Maximum Ratings

|                       |                        |
|-----------------------|------------------------|
| RF Input (Vcc = +5V)  | +13 dBm                |
| Vcc                   | +5.5V                  |
| VLogic                | Vcc -1.6V to Vcc -1.2V |
| Storage Temperature   | -65 to +150 °C         |
| Operating Temperature | -55 to +85 °C          |

### Typical Supply Current vs. Vcc

| Vcc (V) | Icc (mA) |
|---------|----------|
| 4.75    | 61       |
| 5.0     | 68       |
| 5.25    | 74       |

Note: Divider will operate over full voltage range shown above

### Outline Drawing

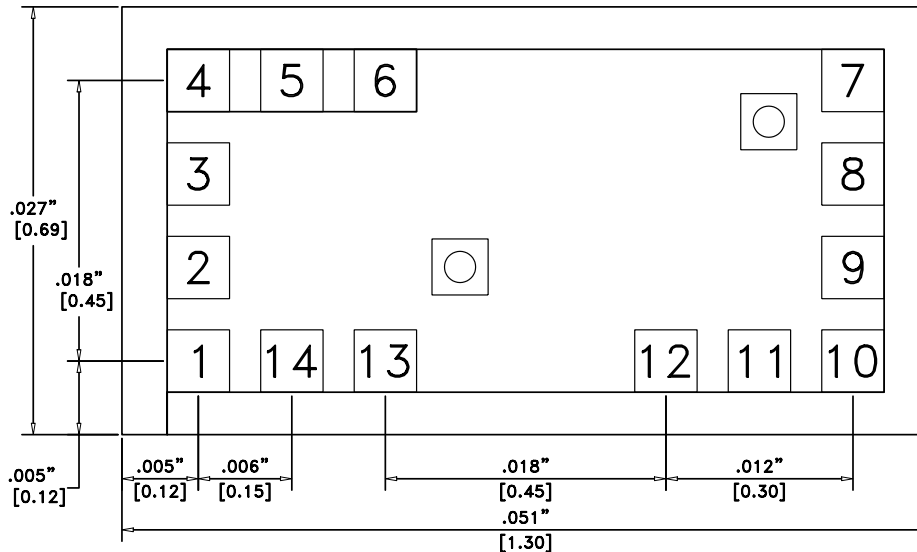



NOTES:

1. ALL DIMENSIONS IN INCHES (MILLIMETERS)
2. ALL TOLERANCES ARE  $\pm 0.001$  (0.025)
3. DIE THICKNESS IS 0.004 (0.100) BACKSIDE IS GROUND
4. BOND PADS ARE 0.004 (0.100) SQUARE
5. BOND PAD SPACING, CTR-CTR: 0.006 (0.150)
6. BACKSIDE METALLIZATION: GOLD
7. BOND PAD METALLIZATION: GOLD

## GaAs HBT MMIC DIVIDE-BY-4, DC - 11.0 GHz

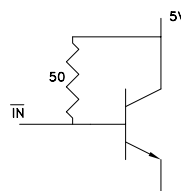
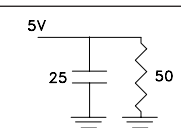
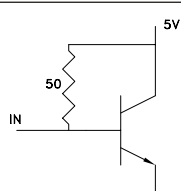
### Pad Description

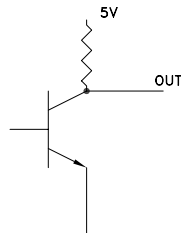
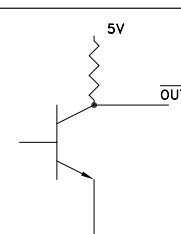
| Pad Number | Function                | Description  | Interface Schematic   |
|------------|-------------------------|--|---|
| 1          | $\overline{\text{IN}}$  | RF Input 180° out of phase with pad 3 for differential operation.<br>AC ground for single ended operation. |    |
| 2          | N/C                     | Not Connected  |   |
| 4, 5, 6    | VCC                     | Supply Voltage 5V ±0.25V can be applied to pad 4, 5, or 6.   |    |
| 3          | IN                      | RF Input must be DC blocked.   |   |
| 7, 11, 12  | GND                     | Ground: These pads are grounded.   |  |
| 8          | OUT                     | Divided Output   |  |
| 9          | $\overline{\text{OUT}}$ | Divided output 180° out of phase with pad 8.   |  |

## GaAs HBT MMIC DIVIDE-BY-4, DC - 11.0 GHz

### Pad Description (continued)

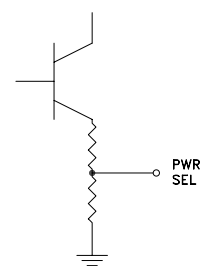
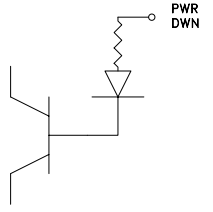
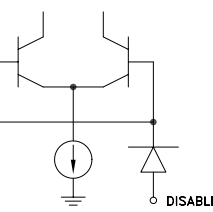
| Pad Number | Function | Description  | Interface Schematic  |
|------------|----------|--|--|
| 10         | PWR SEL  | In the low power mode, the power select pin is left floating.<br>By grounding this pin, the output power is increased by approximately 6 dB. |   |
| 13         | PWR DWN  | The power down pin is grounded for normal operation.<br>Applying 5 volts to this pin will power down this device.                            |   |
| 14         | DISABLE  | The disable pin is grounded for normal operation.<br>Applying 5 volts to this pin will disable the input buffer amplifier.                   |  |

### Truth Table

| Function | Pin | 5V         | GND               | Float            |
|----------|-----|------------|-------------------|------------------|
| DISABLE  | 14  | Output Off | Output On         | X                |
| PWR DWN  | 13  | Power Down | Power Up          | X                |
| PWR SEL  | 10  | X          | High Power Output | Low Power Output |

X = State not permitted.

### Assembly Diagram

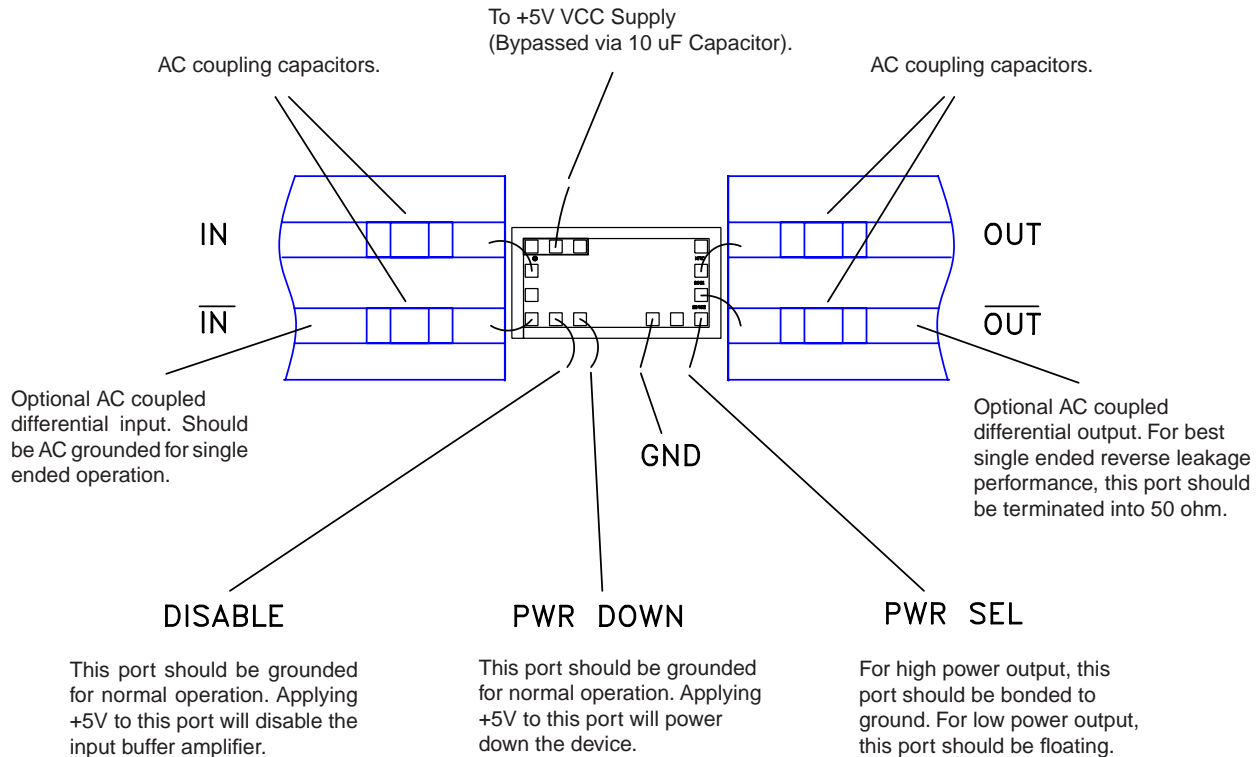

### Handling Precautions

Follow these precautions to avoid permanent damage.

**Cleanliness:** Handle the chips in a clean environment. DO NOT attempt to clean the chip using liquid cleaning systems.

**Static Sensitivity:** Follow ESD precautions to protect against  $> \pm 250V$  ESD strikes.

**Transients:** Suppress instrument and bias supply transients while bias is applied. Use shielded signal and bias cables to minimize inductive pick-up.

**General Handling:** Handle the chip along the edges with a vacuum collet or with a sharp pair of bent tweezers. The surface of the chip has fragile air bridges and should not be touched with vacuum collet, tweezers, or fingers.

### Mounting

The chip is back-metallized and can be die mounted with AuSn eutectic preforms or with electrically conductive epoxy. The mounting surface should be clean and flat.

**Eutectic Die Attach:** A 80/20 gold tin preform is recommended with a work surface temperature of 255 °C and a tool temperature of 265 °C. When hot 90/10 nitrogen/hydrogen gas is applied, tool tip temperature should be 290 °C. DO NOT expose the chip to a temperature greater than 320 °C for more than 20 seconds. No more than 3 seconds of scrubbing should be required for attachment.

**Epoxy Die Attach:** Apply a minimum amount of epoxy to the mounting surface so that a thin epoxy fillet is observed around the perimeter of the chip once it is placed into position. Cure epoxy per the manufacturer's schedule.

### Wire Bonding

Ball or wedge bond with 0.025 mm (1 mil) diameter pure gold wire. Thermosonic wirebonding with a nominal stage temperature of 150 °C and a ball bonding force of 40 to 50 grams or wedge bonding force of 18 to 22 grams is recommended. Use the minimum level of ultrasonic energy to achieve reliable wirebonds. Wirebonds should be started on the chip and terminated on the package or substrate. All bonds should be as short as possible  $< 0.31$  mm (12 mils).



LittleDiode supplies new, hard to find or obsolete electronic components and semiconductors all over the world.

With over two million different components listed you are sure to find the part you need.

Feel free to visit us today at our online store:

[LittleDiode.com](http://LittleDiode.com)

Looking forward to providing you with the best possible service.