

# DATA SHEET



## **PCA9535**

16-bit I<sup>2</sup>C and SMBus, low power I/O port  
with interrupt

Product data

2003 Jun 27

16-bit I<sup>2</sup>C and SMBus, low power I/O port with interrupt

PCA9535

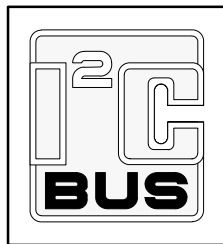

## FEATURES

- Operating power supply voltage range of 2.3 V-5.5 V
- 5 V tolerant I/Os
- Polarity inversion register
- Active LOW interrupt output
- Low stand-by current
- Noise filter on SCL/SDA inputs
- No glitch on power-up
- Internal power-on reset
- 16 I/O pins which default to 16 inputs
- 0 to 400 kHz clock frequency
- ESD protection exceeds 2000 V HBM per JESD22-A114, 200 V MM per JESD22-A115, and 1000 V CDM per JESD22-C101
- Latch-up testing is done to JESDEC Standard JESD78 which exceeds 100 mA
- Offered in three different packages: SO24, TSSOP24, and HVQFN24

## DESCRIPTION

The PCA9535 is a 24-pin CMOS device that provide 16 bits of General Purpose parallel Input/Output (GPIO) expansion for

## ORDERING INFORMATION

PACKAGES	TEMPERATURE RANGE	ORDER CODE	TOPSIDE MARK	DRAWING NUMBER
24-Pin Plastic SO	-40 to +85 °C	PCA9535D	PCA9535D	SOT137-1
24-Pin Plastic TSSOP	-40 to +85 °C	PCA9535PW	PCA9535PW	SOT355-1
24-Pin Plastic HVQFN	-40 to +85 °C	PCA9535BS	9535	SOT616-1

Standard packing quantities and other packing data are available at [www.philipslogic.com/packaging](http://www.philipslogic.com/packaging).

I<sup>2</sup>C is a trademark of Philips Semiconductors Corporation.

SMBus as specified by the Smart Battery System Implementers Forum is a derivative of the Philips I<sup>2</sup>C patent.

I<sup>2</sup>C/SMBus applications and was developed to enhance the Philips family of I<sup>2</sup>C I/O expanders. The improvements include higher drive capability, 5 V I/O tolerance, lower supply current, individual I/O configuration, and smaller packaging. I/O expanders provide a simple solution when additional I/O is needed for ACPI power switches, sensors, pushbuttons, LEDs, fans, etc.

The PCA9535 consist of two 8-bit Configuration (Input or Output selection); Input, Output and Polarity inversion (Active HIGH or Active LOW operation) registers. The system master can enable the I/Os as either inputs or outputs by writing to the I/O configuration bits. The data for each Input or Output is kept in the corresponding Input or Output register. The polarity of the read register can be inverted with the Polarity Inversion Register. All registers can be read by the system master. Although pin-to-pin and I<sup>2</sup>C address compatible with the PCF8575, software changes are required due to the enhancements and are discussed in Application Note AN469.

The PCA9535 is identical to the PCA9555 except for the removal of the internal I/O pull-up resistor which greatly reduces power consumption when the I/Os are held LOW.

The PCA9535 open-drain interrupt output is activated when any input state differs from its corresponding input port register state and is used to indicate to the system master that an input state has changed. The power-on reset sets the registers to their default values and initializes the device state machine.

Three hardware pins (A0, A1, A2) vary the fixed I<sup>2</sup>C address and allow up to eight devices to share the same I<sup>2</sup>C/SMBus. The fixed I<sup>2</sup>C address of the PCA9535 is the same as the PCA9554 allowing up to eight of these devices in any combination to share the same I<sup>2</sup>C/SMBus.

# 16-bit I<sup>2</sup>C and SMBus, low power I/O port with interrupt

PCA9535

## PIN CONFIGURATION — SO, TSSOP

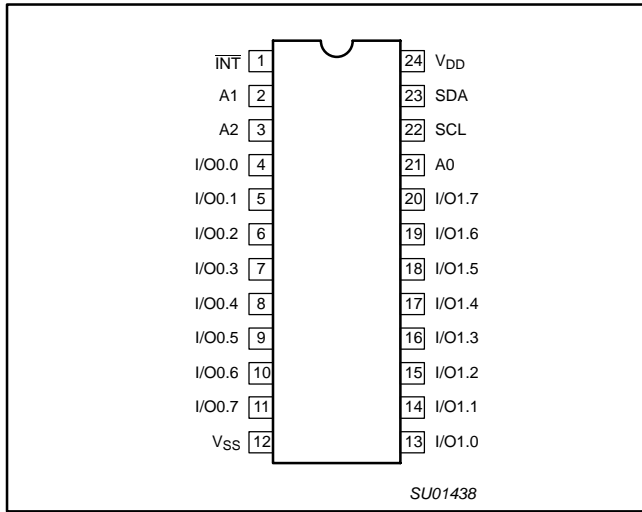

Figure 1. Pin configuration — SO, TSSOP

## PIN CONFIGURATION —HVQFN

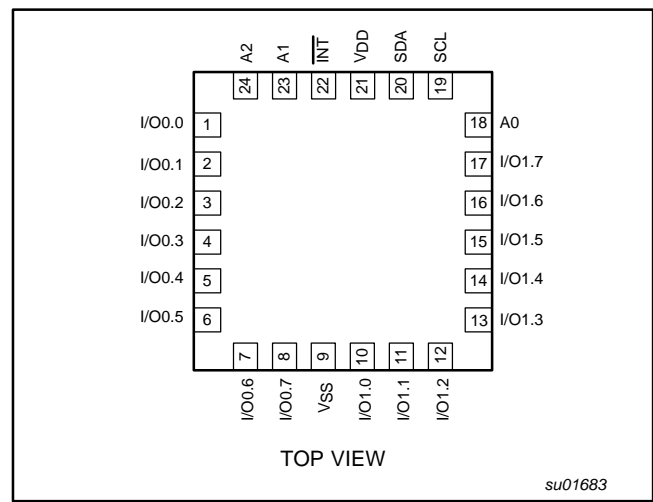

Figure 2. Pin configuration — HVQFN

## PIN DESCRIPTION

SO, TSSOP PIN NUMBER	HVQFN PIN NUMBER	SYMBOL	FUNCTION
1	22	INT	Interrupt output (open drain)
2	23	A1	Address input 1
3	24	A2	Address input 2
4-11	1-8	I/O0.0-I/O0.7	I/O0.0 to I/O0.7
12	9	V <sub>SS</sub>	Supply ground
13-20	10-17	I/O1.0-I/O1.7	I/O1.0 to I/O1.7
21	18	A0	Address input 0
22	19	SCL	Serial clock line
23	20	SDA	Serial data line
24	21	V <sub>DD</sub>	Supply voltage

# 16-bit I<sup>2</sup>C and SMBus, low power I/O port with interrupt

PCA9535

## BLOCK DIAGRAM

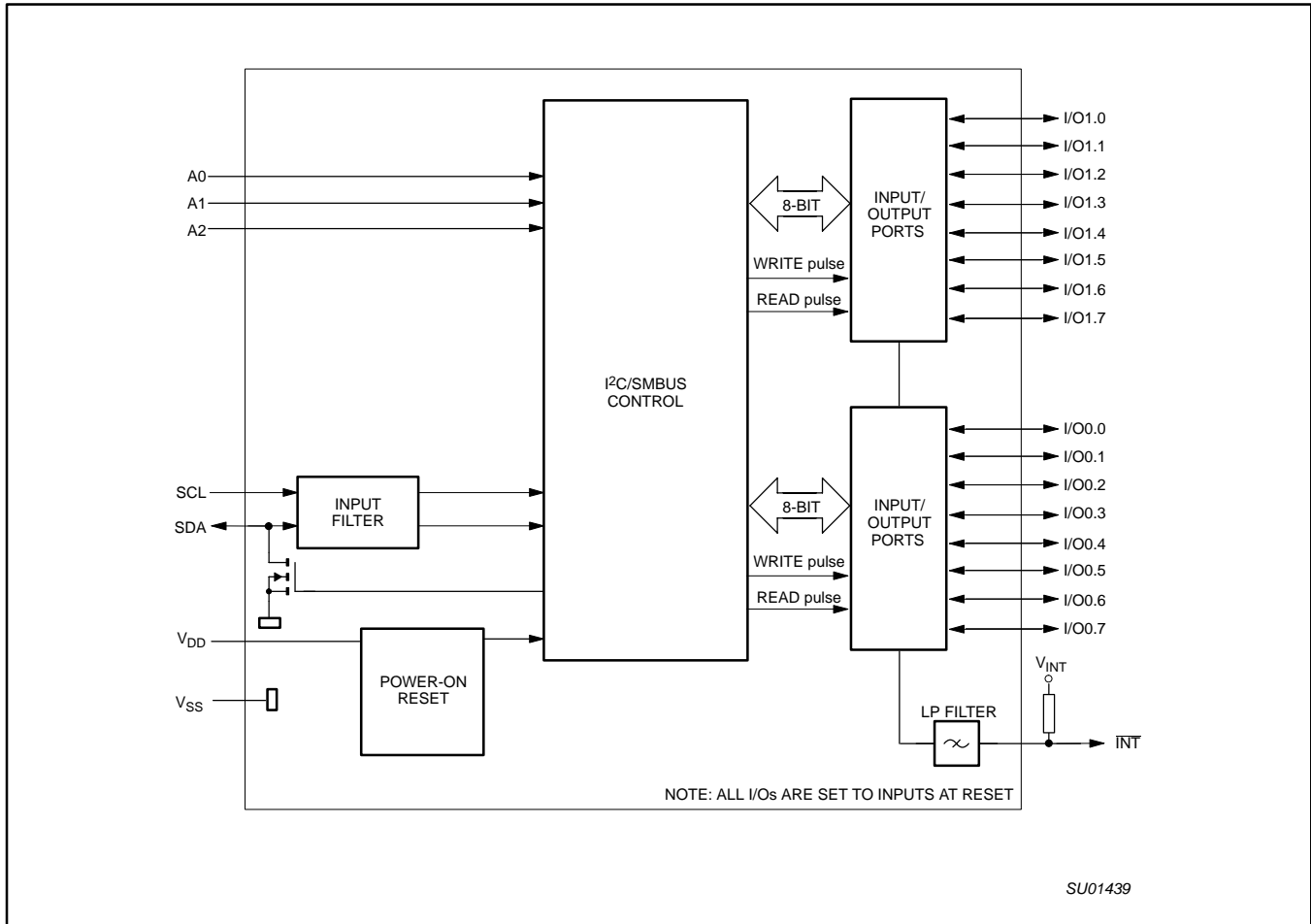
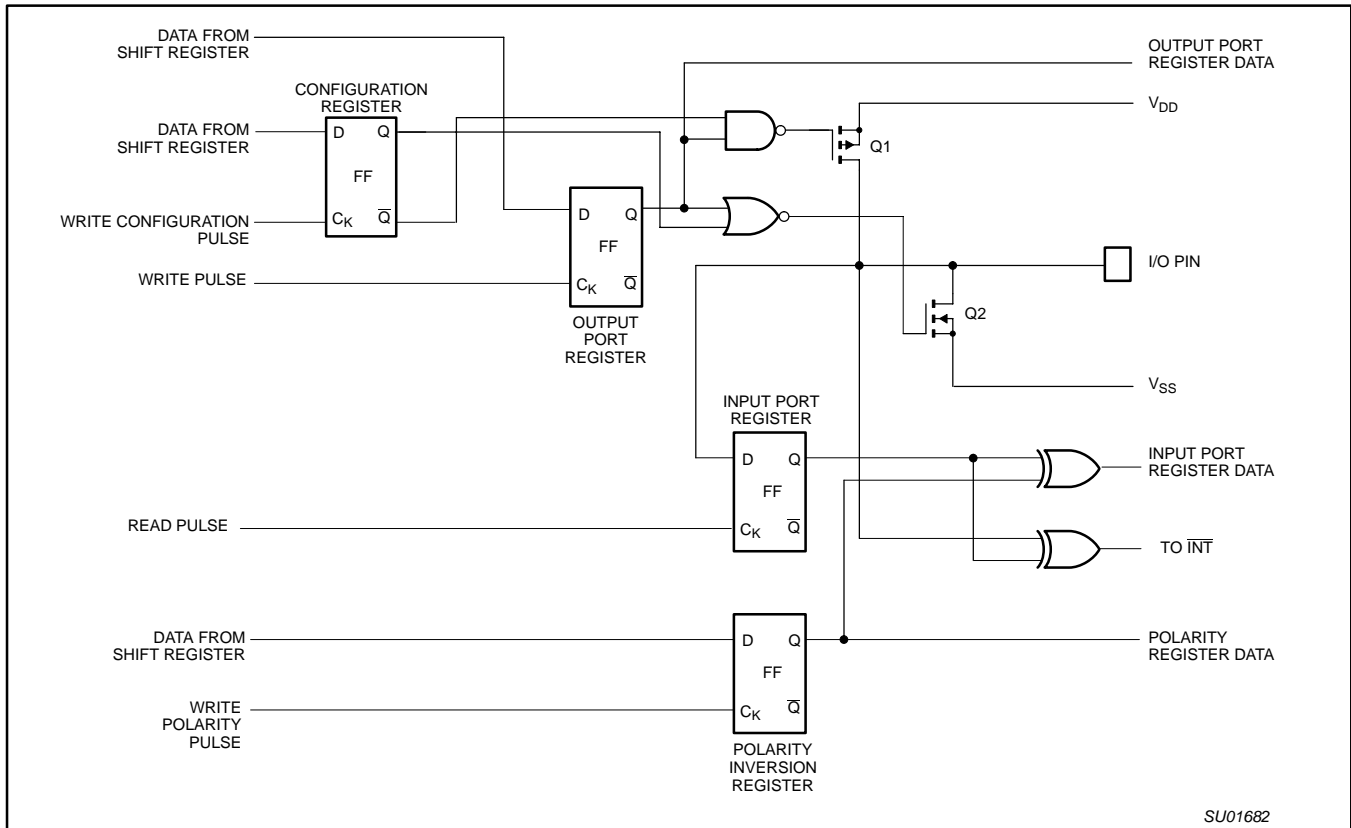

Figure 3. Block diagram

# 16-bit I<sup>2</sup>C and SMBus, low power I/O port with interrupt

PCA9535

## SIMPLIFIED SCHEMATIC OF I/Os



SU01682

**NOTE:** At Power-on Reset, all registers return to default values.

**Figure 4. Simplified schematic of I/Os**

### I/O port

When an I/O is configured as an input, FETs Q1 and Q2 are off, creating a high impedance input. The input voltage may be raised above  $V_{DD}$  to a maximum of 5.5 V.

If the I/O is configured as an output, then either Q1 or Q2 is on, depending on the state of the Output Port register. Care should be exercised if an external voltage is applied to an I/O configured as an output because of the low impedance path that exists between the pin and either  $V_{DD}$  or  $V_{SS}$ .

# 16-bit I<sup>2</sup>C and SMBus, low power I/O port with interrupt

# PCA9535

## REGISTERS

### Command Byte

Command	Register
0	Input port 0
1	Input port 1
2	Output port 0
3	Output port 1
4	Polarity inversion port 0
5	Polarity inversion port 1
6	Configuration port 0
7	Configuration port 1

The command byte is the first byte to follow the address byte during a write transmission. It is used as a pointer to determine which of the following registers will be written or read.

### Registers 0 and 1 — Input Port Registers

This register is an input-only port. It reflects the incoming logic levels of the pins, regardless of whether the pin is defined as an input or an output by Register 3. Writes to this register have no effect.

### Registers 2 and 3 — Output Port Registers

bit	O0.7	O0.6	O0.5	O0.4	O0.3	O0.2	O0.1	O0.0
default	1	1	1	1	1	1	1	1
bit	O1.7	O1.6	O1.5	O1.4	O1.3	O1.2	O1.1	O1.0
default	1	1	1	1	1	1	1	1

This register is an output-only port. It reflects the outgoing logic levels of the pins defined as outputs by Register 6 and 7. Bit values in this register have no effect on pins defined as inputs. In turn, reads from this register reflect the value that is in the flip-flop controlling the output selection, NOT the actual pin value.

### Registers 4 and 5 — Polarity Inversion Registers

bit	N0.7	N0.6	N0.5	N0.4	N0.3	N0.2	N0.1	N0.0
default	0	0	0	0	0	0	0	0
bit	N1.7	N1.6	N1.5	N1.4	N1.3	N1.2	N1.1	N1.0
default	0	0	0	0	0	0	0	0

This register allows the user to invert the polarity of the Input Port register data. If a bit in this register is set (written with '1'), the Input Port data polarity is inverted. If a bit in this register is cleared (written with a '0'), the Input Port data polarity is retained.

### Registers 6 and 7 — Configuration Registers

bit	C0.7	C0.6	C0.5	C0.4	C0.3	C0.2	C0.1	C0.0
default	1	1	1	1	1	1	1	1
bit	C1.7	C1.6	C1.5	C1.4	C1.3	C1.2	C1.1	C1.0
default	1	1	1	1	1	1	1	1

This register configures the directions of the I/O pins. If a bit in this register is set (written with '1'), the corresponding port pin is enabled as an input with high impedance output driver. If a bit in this register is cleared (written with '0'), the corresponding port pin is enabled as an output. At reset the device's ports are inputs.

## POWER-ON RESET

When power is applied to V<sub>DD</sub>, an internal power-on reset holds the PCA9535 in a reset state until V<sub>DD</sub> has reached V<sub>POR</sub>. At that point, the reset condition is released and the PCA9535 registers and SMBus state machine will initialize to their default states.

## DEVICE ADDRESS

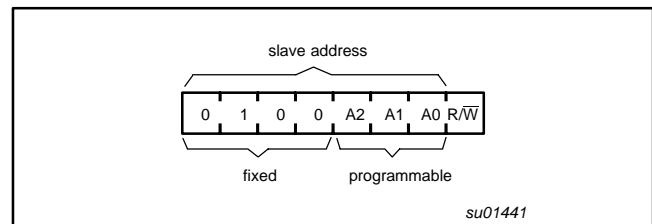

Figure 5. PCA9535 address

## BUS TRANSACTIONS

### Writing to the port registers

Data is transmitted to the PCA9535 by sending the device address and setting the least significant bit to a logic 0 (see Figure 5 for device address). The command byte is sent after the address and determines which register will receive the data following the command byte.

The eight registers within the PCA9535 are configured to operate as four register pairs. The four pairs are Input Ports, Output Ports, Polarity Inversion Ports, and Configuration Ports. After sending data to one register, the next data byte will be sent to the other register in the pair (see Figures 6 and 7). For example, if the first byte is sent to Output Port (register 3), then the next byte will be stored in Output Port 0 (register 2). There is no limitation on the number of data bytes sent in one write transmission. In this way, each 8-bit register may be updated independently of the other registers.

### Reading the port registers

In order to read data from the PCA9535, the bus master must first send the PCA9535 address with the least significant bit set to a logic 0 (see Figure 5 for device address). The command byte is sent after the address and determines which register will be accessed. After a restart, the device address is sent again but this time, the least significant bit is set to a logic 1. Data from the register defined by the command byte will then be sent by the PCA9535 (see Figures 8, 9, and 10). Data is clocked into the register on the falling edge of the acknowledge clock pulse. After the first byte is read, additional bytes may be read but the data will now reflect the information in the other register in the pair. For example, if you read Input Port 1, then the next byte read would be Input Port 0. There is no limitation on the number of data bytes received in one read transmission but the final byte received, the bus master must not acknowledge the data.

### Interrupt Output

The open-drain interrupt output is activated when one of the port pins change state and the pin is configured as an input. The interrupt is deactivated when the input returns to its previous state or the input port register is read (see Figure 9). A pin configured as an output cannot cause an interrupt. Since each 8-bit port is read independently, the interrupt caused by Port 0 will not be cleared by a read of Port 1 or the other way around.

Note that changing an I/O from an output to an input may cause a false interrupt to occur if the state of the pin does not match the contents of the Input Port register.

16-bit I<sup>2</sup>C and SMBus, low power I/O port with interrupt

PCA9535

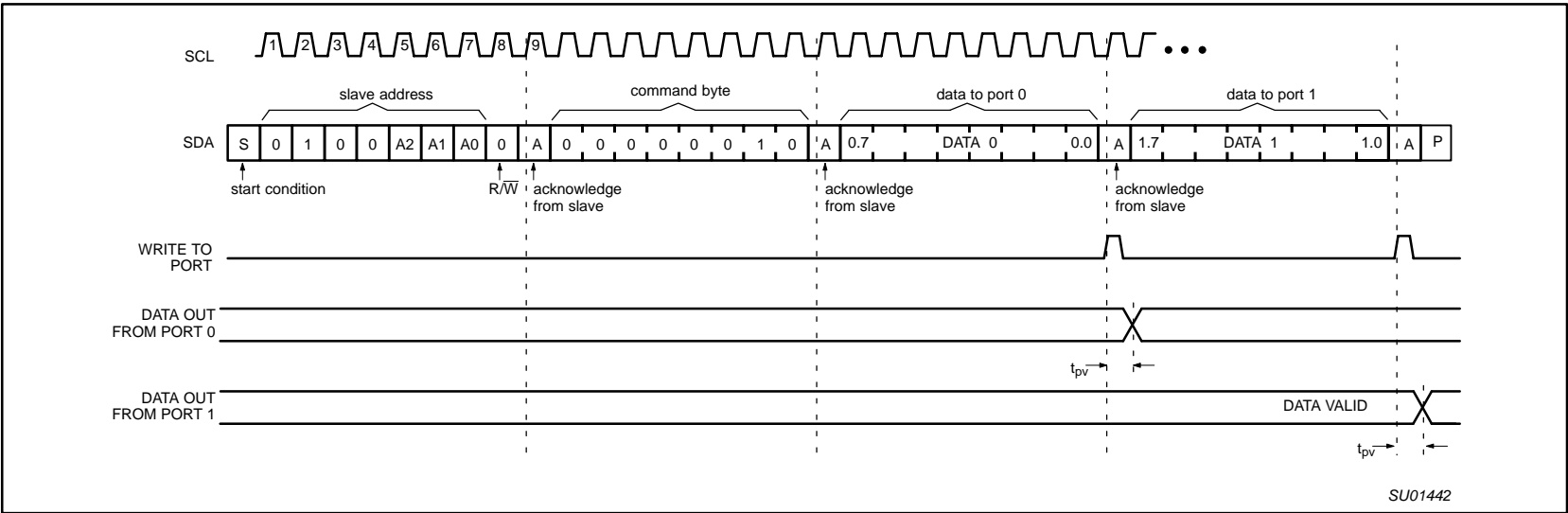

SU01442

Figure 6. WRITE to output port registers

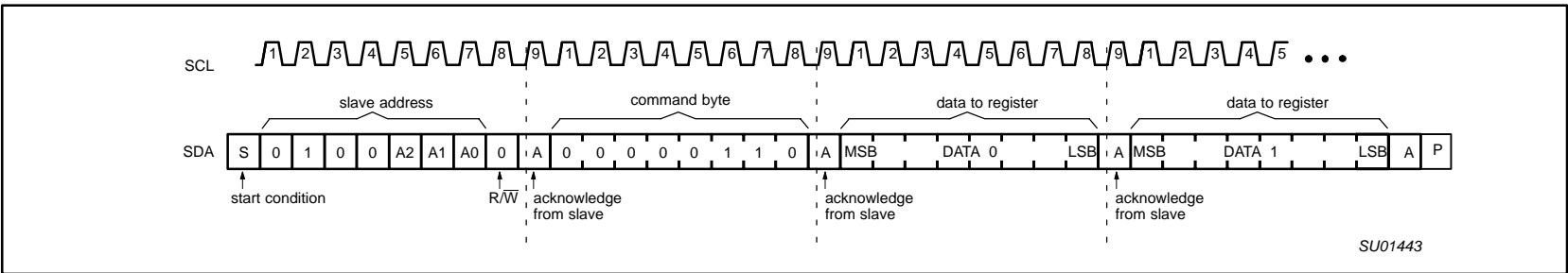

SU01443

Figure 7. WRITE to configuration registers

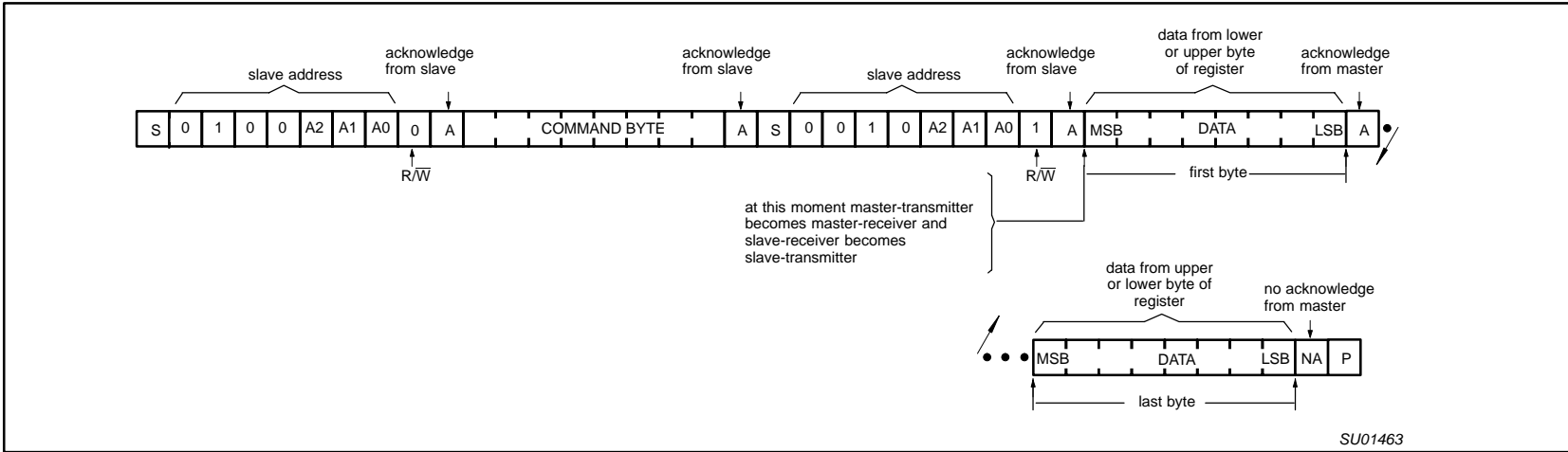

NOTE: Transfer can be stopped at any time by a STOP condition.

Figure 8. READ from register

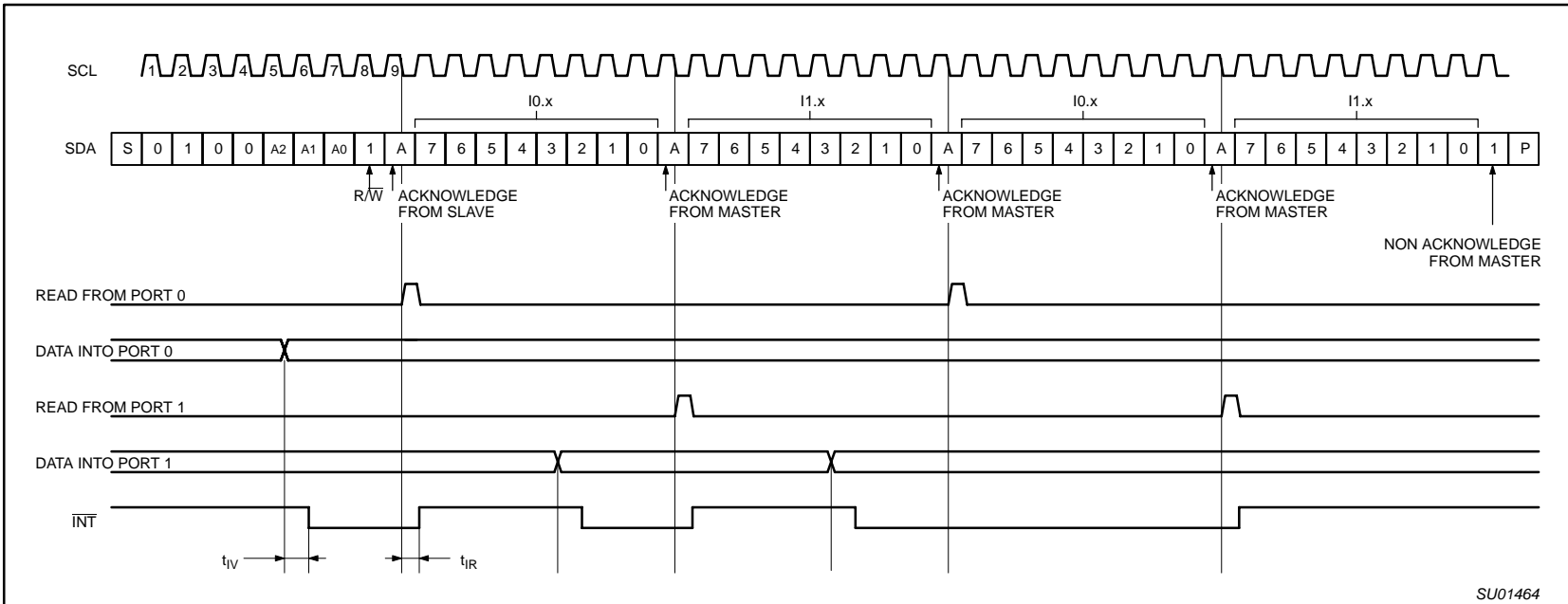

NOTES: Transfer of data can be stopped at any moment by a STOP condition. When this occurs, data present at the latest acknowledge phase is valid (output mode). It is assumed that the command byte has previously been set to 00 (read input port register).

Figure 9. READ input port register — scenario 1

16-bit I<sup>2</sup>C and SMBus, low power I/O port with interrupt

PCA9535

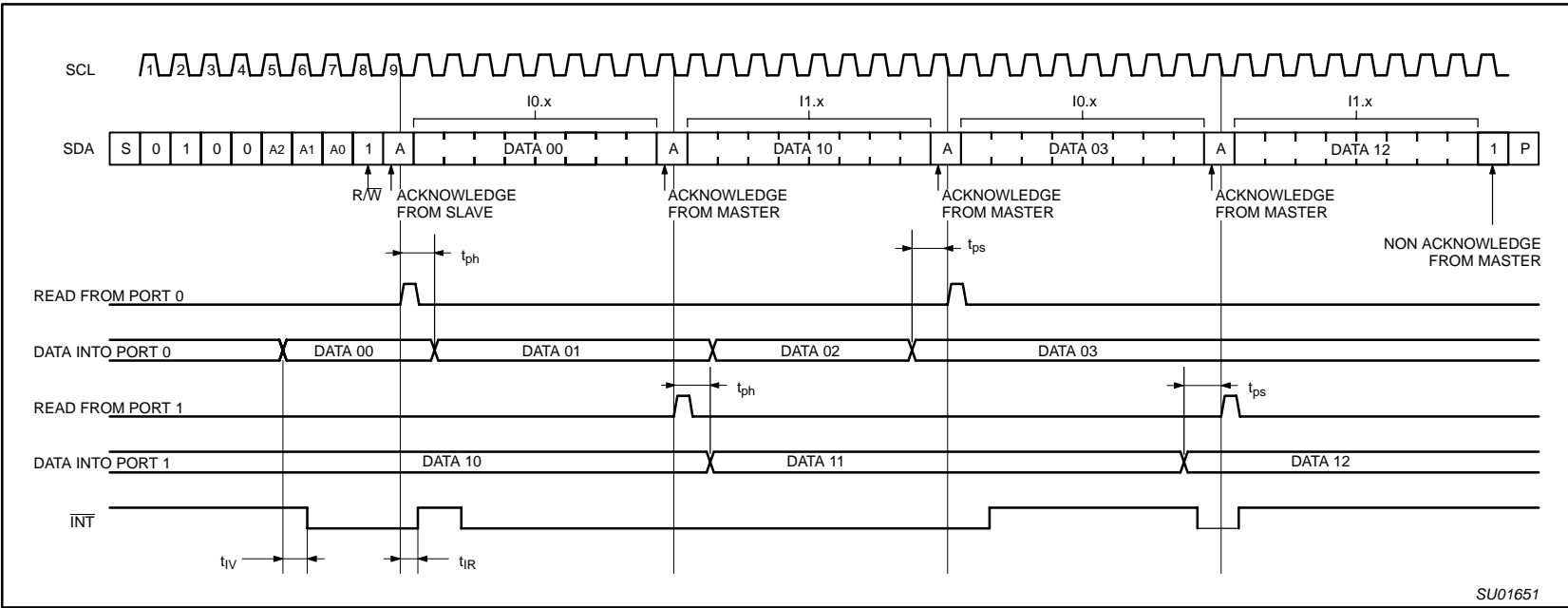

**NOTES:** Transfer of data can be stopped at any moment by a STOP condition. When this occurs, data present at the latest acknowledge phase is valid (output mode). It is assumed that the command byte has previously been set to 00 (read input port register).

Figure 10. READ input port register — scenario 2

# 16-bit I<sup>2</sup>C and SMBus, low power I/O port with interrupt

# PCA9535

## TYPICAL APPLICATION

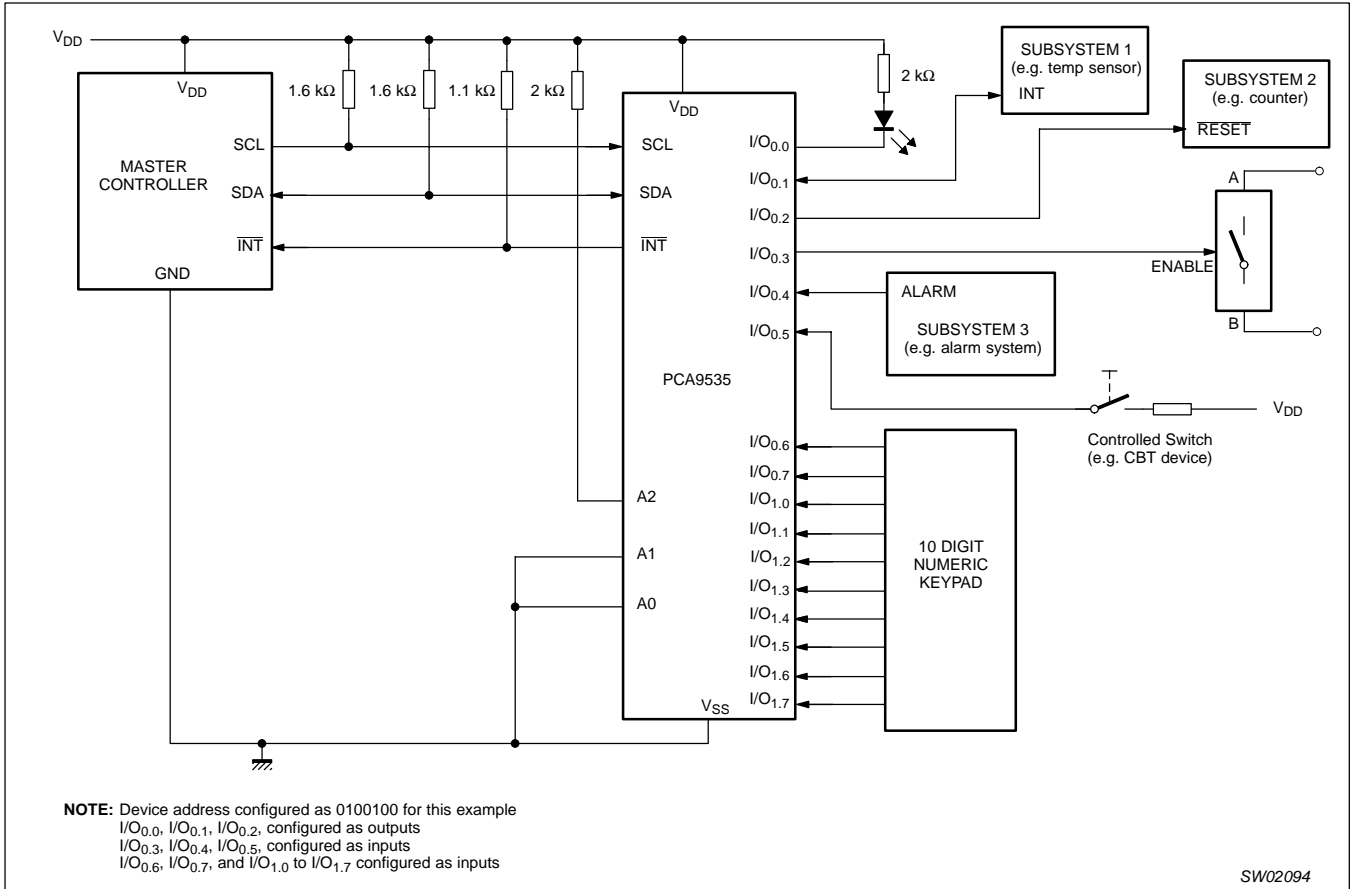

Figure 11. Typical application

### Minimizing I<sub>DD</sub> when the I/O is used to control LEDs

When the I/Os are used to control LEDs, they are normally connected to V<sub>DD</sub> through a resistor as shown in Figure 11. Since the LED acts as a diode, when the LED is off the I/O V<sub>IN</sub> is about 1.2 V less than V<sub>DD</sub>. The supply current, I<sub>DD</sub>, increases as V<sub>IN</sub> becomes lower than V<sub>DD</sub> and is specified as ΔI<sub>DD</sub> in the DC characteristics table.

Designs needing to minimize current consumption, such as battery power applications, should consider maintaining the I/O pins greater than or equal to V<sub>DD</sub> when the LED is off. Figure 12 shows a high value resistor in parallel with the LED. Figure 13 shows V<sub>DD</sub> less than the LED supply voltage by at least 1.2 V. Both of these methods maintain the I/O V<sub>IN</sub> at or above V<sub>DD</sub> and prevents additional supply current consumption when the LED is off.

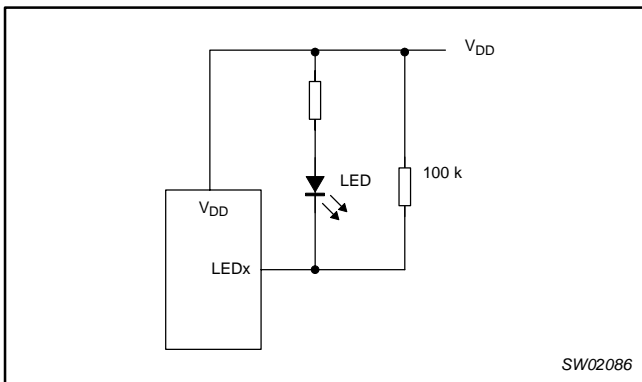

Figure 12. High value resistor in parallel with the LED

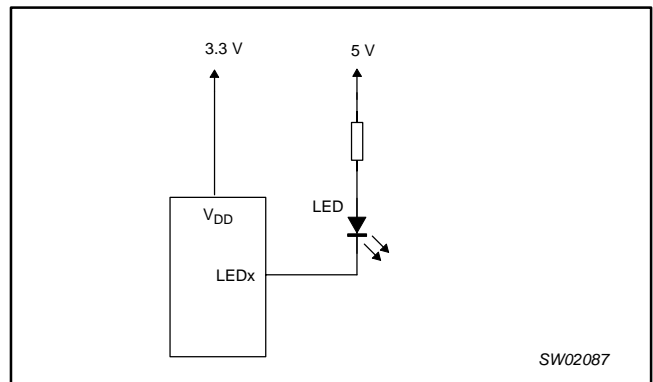

Figure 13. Device supplied by a lower voltage

16-bit I<sup>2</sup>C and SMBus, low power I/O port with interrupt

PCA9535

**ABSOLUTE MAXIMUM RATINGS**

In accordance with the Absolute Maximum Rating System (IEC 134)

SYMBOL	PARAMETER	CONDITIONS	MIN	MAX	UNIT
V <sub>DD</sub>	Supply voltage		-0.5	6.0	V
V <sub>I/O</sub>	DC input current on an I/O		V <sub>SS</sub> - 0.5	6	V
I <sub>I/O</sub>	DC output current on an I/O		—	± 50	mA
I <sub>I</sub>	DC input current		—	± 20	mA
I <sub>DD</sub>	Supply current		—	160	mA
I <sub>SS</sub>	Supply current		—	200	mA
P <sub>tot</sub>	Total power dissipation		—	200	mW
T <sub>stg</sub>	Storage temperature range		-65	+150	°C
T <sub>amb</sub>	Operating ambient temperature		-40	+85	°C

16-bit I<sup>2</sup>C and SMBus, low power I/O port with interrupt

PCA9535

**HANDLING**

Inputs and outputs are protected against electrostatic discharge in normal handling. However, to be totally safe, it is desirable to take precautions appropriate to handling MOS devices. Advice can be found in Data Handbook IC24 under "Handling MOS devices".

**DC CHARACTERISTICS**

$V_{DD} = 2.3$  to  $5.5$  V;  $V_{SS} = 0$  V;  $T_{amb} = -40$  to  $+85$  °C; unless otherwise specified.

SYMBOL	PARAMETER	CONDITIONS	MIN	TYP	MAX	UNIT
<b>Supplies</b>						
$V_{DD}$	Supply voltage		2.3	—	5.5	V
$I_{DD}$	Supply current	Operating mode; $V_{DD} = 5.5$ V; no load; $f_{SCL} = 100$ kHz; I/O = inputs	—	135	200	$\mu$ A
$I_{stbl}$	Standby current	Standby mode; $V_{DD} = 5.5$ V; no load; $V_I = V_{SS}$ ; $f_{SCL} = 0$ kHz; I/O = inputs	—	0.25	1	$\mu$ A
$I_{stbh}$	Standby current	Standby mode; $V_{DD} = 5.5$ V; no load; $V_I = V_{DD}$ ; $f_{SCL} = 0$ kHz; I/O = inputs	—	0.25	1	$\mu$ A
$V_{POR}$	Power-on reset voltage	No load; $V_I = V_{DD}$ or $V_{SS}$	—	1.5	1.65	V
<b>input SCL; input/output SDA</b>						
$V_{IL}$	LOW-level input voltage		-0.5	—	$0.3 V_{DD}$	V
$V_{IH}$	HIGH-level input voltage		$0.7 V_{DD}$	—	5.5	V
$I_{OL}$	LOW-level output current	$V_{OL} = 0.4$ V	3	—	—	mA
$I_L$	Leakage current	$V_I = V_{DD} = V_{SS}$	-1	—	+1	$\mu$ A
$C_I$	Input capacitance	$V_I = V_{SS}$	—	6	10	pF
<b>I/Os</b>						
$V_{IL}$	LOW-level input voltage		-0.5	—	0.8	V
$V_{IH}$	HIGH-level input voltage		2.0	—	5.5	V
$I_{OL}$	LOW-level output current	$V_{OL} = 0.5$ V; $V_{DD} = 2.3$ - $5.5$ V; Note 1	8	8-20	—	mA
		$V_{OL} = 0.7$ V; $V_{DD} = 2.3$ - $5.5$ V; Note 1	10	10-24	—	mA
$V_{OH}$	HIGH-level output voltage	$I_{OH} = -8$ mA; $V_{DD} = 2.3$ V; Note 2	1.8	—	—	V
		$I_{OH} = -10$ mA; $V_{DD} = 2.3$ V; Note 2	1.7	—	—	V
		$I_{OH} = -8$ mA; $V_{DD} = 3.0$ V; Note 2	2.6	—	—	V
		$I_{OH} = -10$ mA; $V_{DD} = 3.0$ V; Note 2	2.5	—	—	V
		$I_{OH} = -8$ mA; $V_{DD} = 4.75$ V; Note 2	4.1	—	—	V
		$I_{OH} = -10$ mA; $V_{DD} = 4.75$ V; Note 2	4.0	—	—	V
$I_{IH}$	Input leakage current	$V_{DD} = 5.5$ V; $V_I = V_{DD}$	—	—	1	$\mu$ A
$I_{IL}$	Input leakage current	$V_{DD} = 5.5$ V; $V_I = V_{SS}$	—	—	-1	$\mu$ A
$C_I$	Input capacitance		—	3.7	5	pF
$C_O$	Output capacitance		—	3.7	5	pF
<b>Interrupt INT</b>						
$I_{OL}$	LOW-level output current	$V_{OL} = 0.4$ V	3	—	—	mA
<b>Select Inputs A0, A1, A2</b>						
$V_{IL}$	LOW-level input voltage		-0.5	—	0.8	V
$V_{IH}$	HIGH-level input voltage		2.0	—	5.5	V
$I_{LI}$	Input leakage current		-1	—	1	$\mu$ A

**NOTES:**

- The total current sunk by all I/Os must be limited to 200 mA.
- The total current sourced by all I/Os must be limited to 160 mA.

# 16-bit I<sup>2</sup>C and SMBus, low power I/O port with interrupt

PCA9535

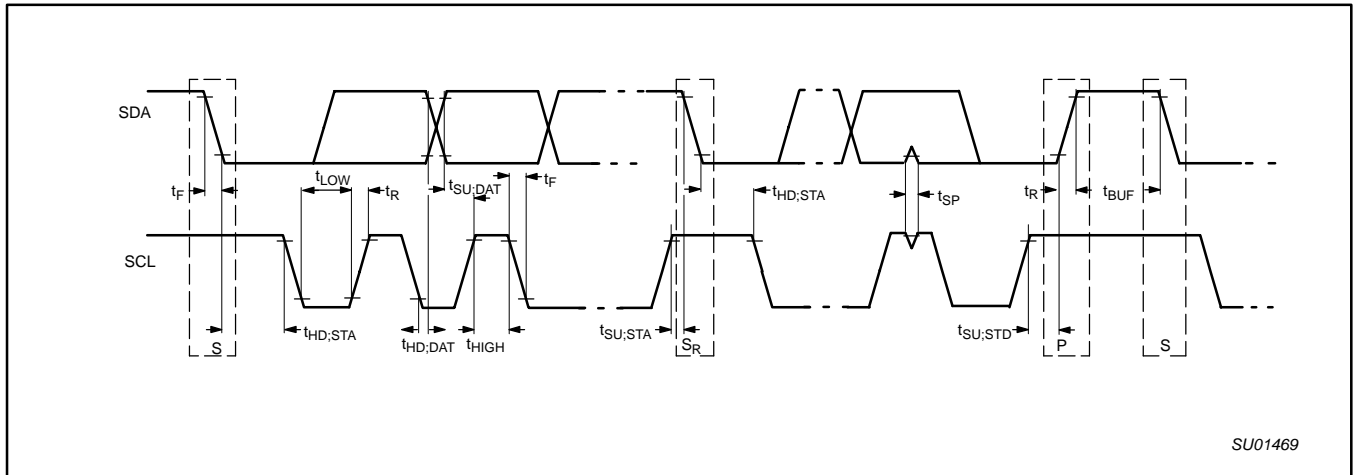

Figure 14. Definition of timing

## AC CHARACTERISTICS

SYMBOL	PARAMETER	STANDARD MODE I <sup>2</sup> C BUS		FAST MODE I <sup>2</sup> C BUS		UNITS
		MIN	MAX	MIN	MAX	
$f_{SCL}$	Operating frequency	0	100	0	400	kHz
$t_{BUF}$	Bus free time between STOP and START conditions	4.7	—	1.3	—	$\mu$ s
$t_{HD,STA}$	Hold time after (repeated) START condition	4.0	—	0.6	—	$\mu$ s
$t_{SU,STA}$	Repeated START condition setup time	4.7	—	0.6	—	$\mu$ s
$t_{SU,STO}$	Set-up time for STOP condition	4.0	—	0.6	—	$\mu$ s
$t_{VD,ACK}$	Valid time of ACK condition <sup>2</sup>	0.3	3.45	0.1	0.9	$\mu$ s
$t_{HD,DAT}$	Data in hold time	0	—	0	—	ns
$t_{VD,DAT}$	Data out valid time <sup>3</sup>	300	—	50	—	ns
$t_{SU,DAT}$	Data set-up time	250	—	100	—	ns
$t_{LOW}$	Clock LOW period	4.7	—	1.3	—	$\mu$ s
$t_{HIGH}$	Clock HIGH period	4.0	—	0.6	—	$\mu$ s
$t_F$	Clock/Data fall time	—	300	$20 + 0.1C_b$ <sup>1</sup>	300	ns
$t_R$	Clock/Data rise time	—	1000	$20 + 0.1C_b$ <sup>1</sup>	300	ns
$t_{SP}$	Pulse width of spikes that must be suppressed by the input filters	—	50	—	50	ns
<b>Port Timing</b>						
$t_{PV}$	Output data valid	—	200	—	200	ns
$t_{PS}$	Input data set-up time	150	—	150	—	ns
$t_{PH}$	Input data hold time	1	—	1	—	$\mu$ s
<b>Interrupt Timing</b>						
$t_{IV}$	Interrupt valid	—	4	—	4	$\mu$ s
$t_{IR}$	Interrupt reset	—	4	—	4	$\mu$ s

**NOTES:**

- $C_b$  = total capacitance of one bus line in pF.
- $t_{VD,ACK}$  = time for Acknowledgement signal from SCL LOW to SDA (out) LOW.
- $t_{VD,DAT}$  = minimum time for SDA data out to be valid following SCL LOW.
- $t_{PV}$  measured from 0.7V<sub>DD</sub> on SCL to 50% I/O output.

16-bit I<sup>2</sup>C and SMBus, low power I/O port with interrupt

PCA9535

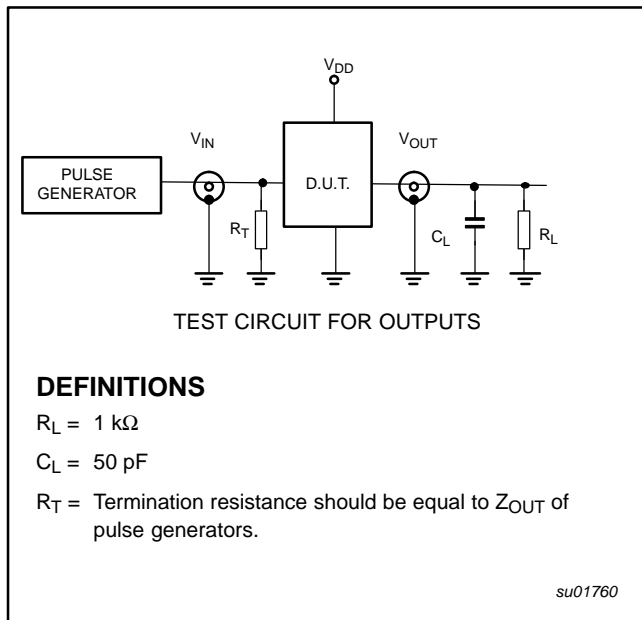
Figure 15.  $t_{pV}$  set-up conditions

16-bit I<sup>2</sup>C and SMBus, low power I/O port with interrupt

PCA9535

SO24: plastic small outline package; 24 leads; body width 7.5 mm

SOT137-1

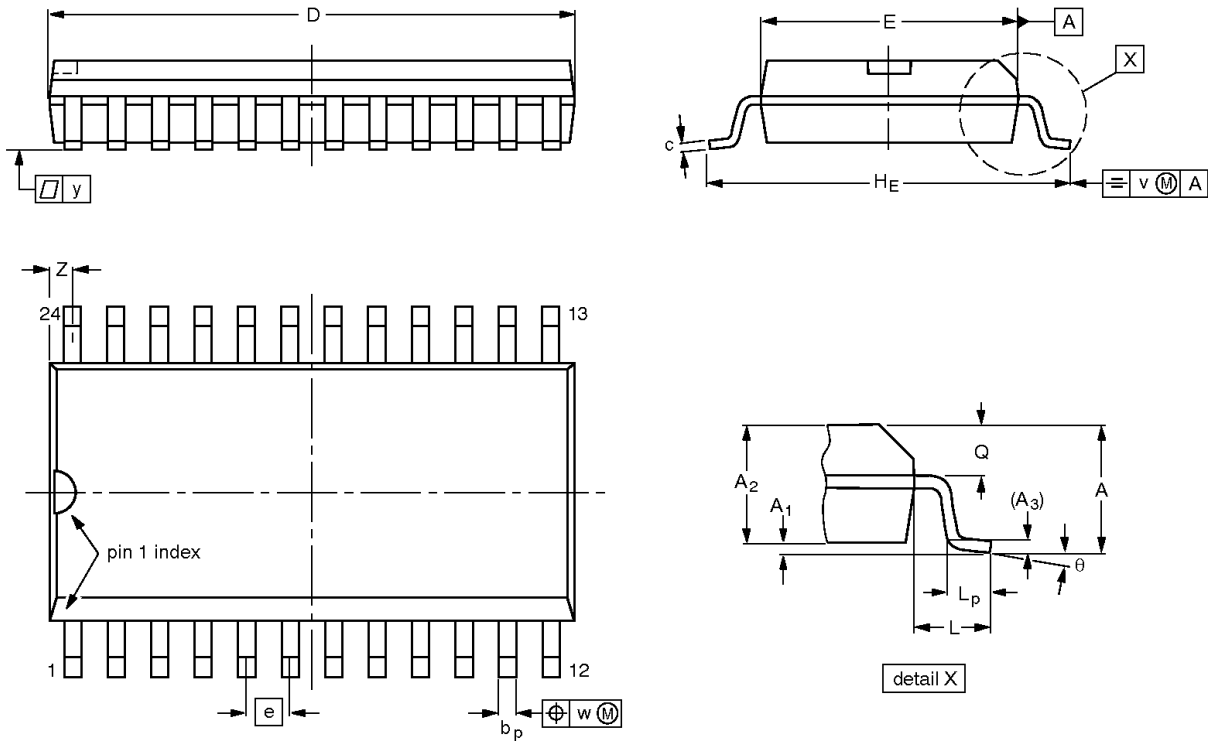

**DIMENSIONS (inch dimensions are derived from the original mm dimensions)**

UNIT	A max.	A <sub>1</sub>	A <sub>2</sub>	A <sub>3</sub>	b <sub>p</sub>	c	D <sup>(1)</sup>	E <sup>(1)</sup>	e	H <sub>E</sub>	L	L <sub>p</sub>	Q	v	w	y	Z <sup>(1)</sup>	θ
mm	2.65	0.3 0.1	2.45 2.25	0.25	0.49 0.36	0.32 0.23	15.6 15.2	7.6 7.4	1.27	10.65 10.00	1.4	1.1 0.4	1.1 1.0	0.25	0.25	0.1	0.9 0.4	8° 0°
inches	0.1	0.012 0.004	0.096 0.089	0.01	0.019 0.014	0.013 0.009	0.61 0.60	0.30 0.29	0.05	0.419 0.394	0.055	0.043 0.016	0.043 0.039	0.01	0.01	0.004	0.035 0.016	

**Note**

1. Plastic or metal protrusions of 0.15 mm (0.006 inch) maximum per side are not included.

OUTLINE VERSION	REFERENCES				EUROPEAN PROJECTION	ISSUE DATE
	IEC	JEDEC	JEITA			
SOT137-1	075E05	MS-013				99-12-27 03-02-19

16-bit I<sup>2</sup>C and SMBus, low power I/O port with interrupt

PCA9535

TSSOP24: plastic thin shrink small outline package; 24 leads; body width 4.4 mm

SOT355-1

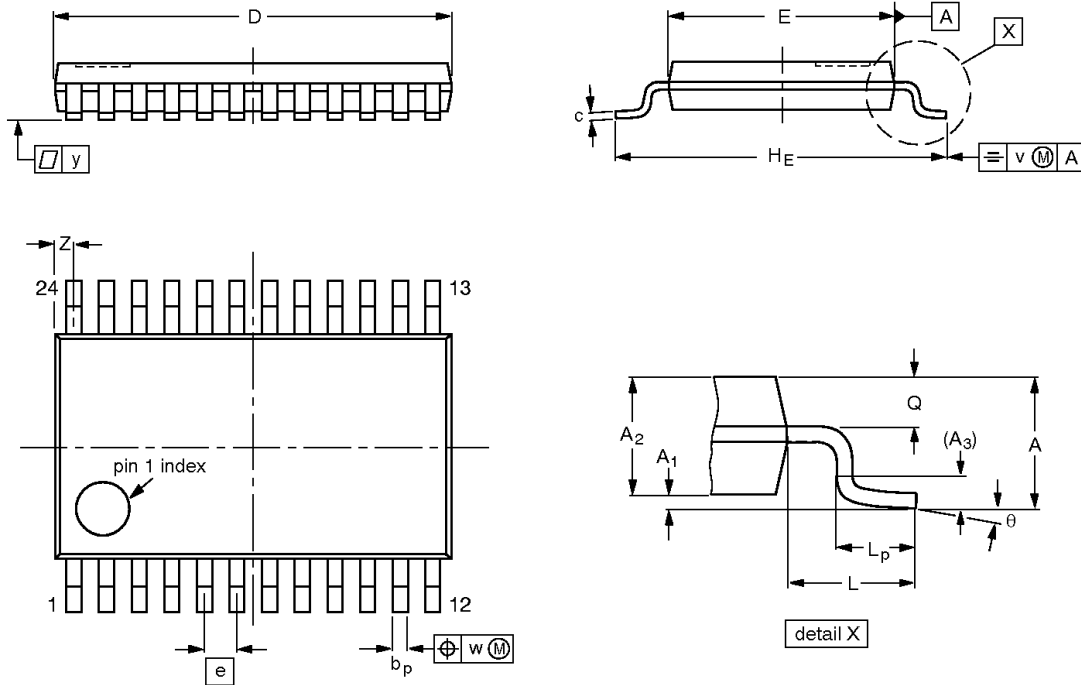

**DIMENSIONS (mm are the original dimensions)**

UNIT	A max.	A <sub>1</sub>	A <sub>2</sub>	A <sub>3</sub>	b <sub>p</sub>	c	D <sup>(1)</sup>	E <sup>(2)</sup>	e	H <sub>E</sub>	L	L <sub>p</sub>	Q	v	w	y	Z <sup>(1)</sup>	θ
mm	1.1	0.15 0.05	0.95 0.80	0.25	0.30 0.19	0.2 0.1	7.9 7.7	4.5 4.3	0.65	6.6 6.2	1	0.75 0.50	0.4 0.3	0.2	0.13	0.1	0.5 0.2	8° 0°

**Notes**

1. Plastic or metal protrusions of 0.15 mm maximum per side are not included.
2. Plastic interlead protrusions of 0.25 mm maximum per side are not included.

OUTLINE VERSION	REFERENCES				EUROPEAN PROJECTION	ISSUE DATE
	IEC	JEDEC	JEITA			
SOT355-1		MO-153				99-12-27 03-02-19

# 16-bit I<sup>2</sup>C and SMBus, low power I/O port with interrupt

PCA9535

**HVQFN24:** plastic thermal enhanced very thin quad flat package; no leads; 24 terminals;  
body 4 x 4 x 0.85 mm

**SOT616-1**

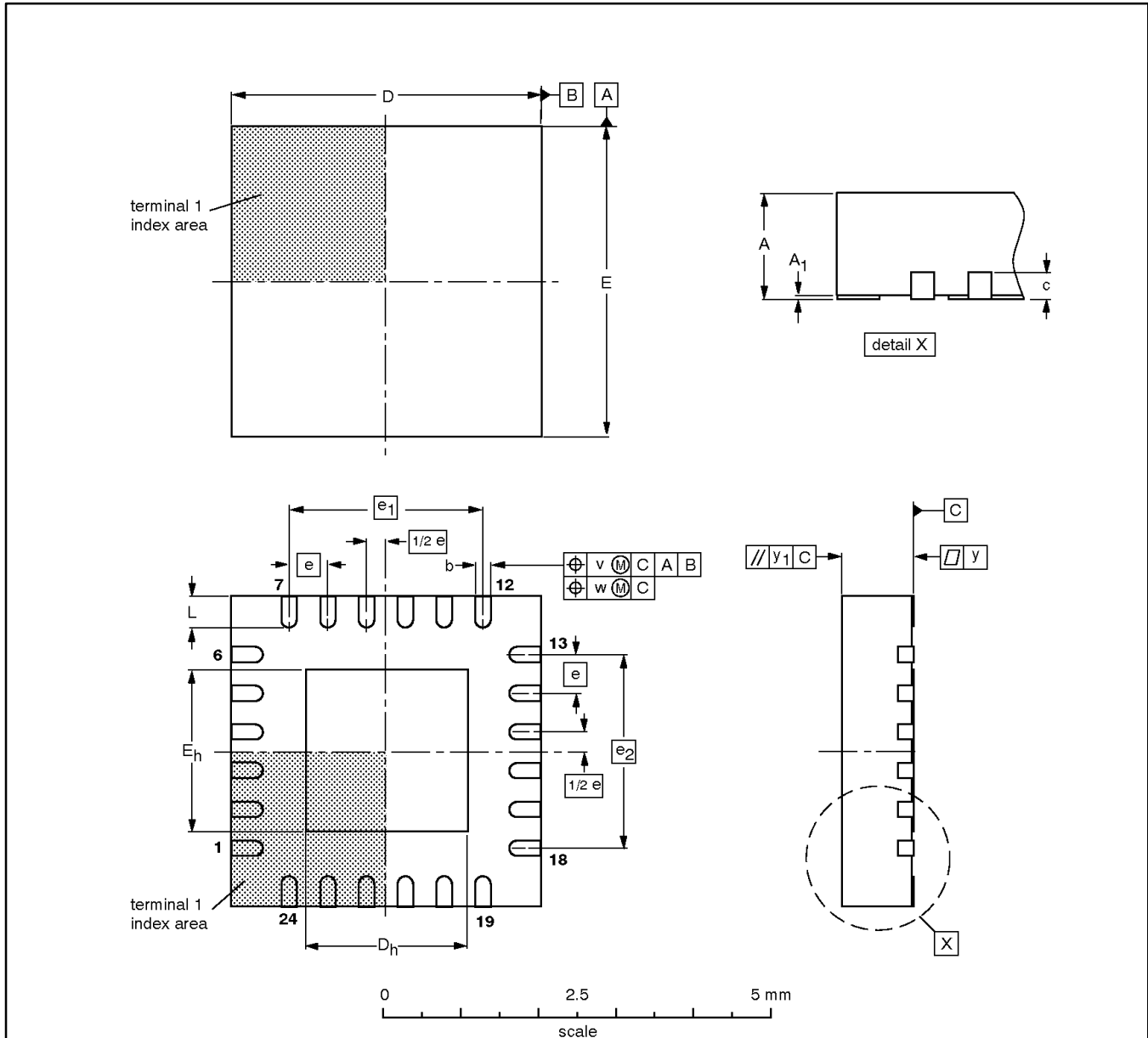

**DIMENSIONS (mm are the original dimensions)**

UNIT	A <sup>(1)</sup> max.	A <sub>1</sub>	b	c	D <sup>(1)</sup>	D <sub>h</sub>	E <sup>(1)</sup>	E <sub>h</sub>	e	e <sub>1</sub>	e <sub>2</sub>	L	v	w	y	y <sub>1</sub>
mm	1	0.05 0.00	0.30 0.18	0.2	4.1 3.9	2.25 1.95	4.1 3.9	2.25 1.95	0.5	2.5	2.5	0.5 0.3	0.1	0.05	0.05	0.1

**Note**

1. Plastic or metal protrusions of 0.075 mm maximum per side are not included.

OUTLINE VERSION	REFERENCES				EUROPEAN PROJECTION	ISSUE DATE
	IEC	JEDEC	JEITA			
SOT616-1	---	MO-220	---			<del>01-09-09</del> 02-10-22

---

**16-bit I<sup>2</sup>C and SMBus, low power I/O port with interrupt****PCA9535**

---

**REVISION HISTORY**

<b>Rev</b>	<b>Date</b>	<b>Description</b>
_1	20030627	<b>Product data (9397 750 11681); ECN 853-2430 30019 dated 11 June 2003. Initial version</b>

16-bit I<sup>2</sup>C and SMBus, low power I/O port with interrupt

PCA9535



Purchase of Philips I<sup>2</sup>C components conveys a license under the Philips' I<sup>2</sup>C patent to use the components in the I<sup>2</sup>C system provided the system conforms to the I<sup>2</sup>C specifications defined by Philips. This specification can be ordered using the code 9398 393 40011.

## Data sheet status

Level	Data sheet status <sup>[1]</sup>	Product status <sup>[2]</sup> [3]	Definitions
I	Objective data	Development	This data sheet contains data from the objective specification for product development. Philips Semiconductors reserves the right to change the specification in any manner without notice.
II	Preliminary data	Qualification	This data sheet contains data from the preliminary specification. Supplementary data will be published at a later date. Philips Semiconductors reserves the right to change the specification without notice, in order to improve the design and supply the best possible product.
III	Product data	Production	This data sheet contains data from the product specification. Philips Semiconductors reserves the right to make changes at any time in order to improve the design, manufacturing and supply. Relevant changes will be communicated via a Customer Product/Process Change Notification (CPCN).

[1] Please consult the most recently issued data sheet before initiating or completing a design.

[2] The product status of the device(s) described in this data sheet may have changed since this data sheet was published. The latest information is available on the Internet at URL <http://www.semiconductors.philips.com>.

[3] For data sheets describing multiple type numbers, the highest-level product status determines the data sheet status.

## Definitions

**Short-form specification** — The data in a short-form specification is extracted from a full data sheet with the same type number and title. For detailed information see the relevant data sheet or data handbook.

**Limiting values definition** — Limiting values given are in accordance with the Absolute Maximum Rating System (IEC 60134). Stress above one or more of the limiting values may cause permanent damage to the device. These are stress ratings only and operation of the device at these or at any other conditions above those given in the Characteristics sections of the specification is not implied. Exposure to limiting values for extended periods may affect device reliability.

**Application information** — Applications that are described herein for any of these products are for illustrative purposes only. Philips Semiconductors make no representation or warranty that such applications will be suitable for the specified use without further testing or modification.

## Disclaimers

**Life support** — These products are not designed for use in life support appliances, devices, or systems where malfunction of these products can reasonably be expected to result in personal injury. Philips Semiconductors customers using or selling these products for use in such applications do so at their own risk and agree to fully indemnify Philips Semiconductors for any damages resulting from such application.

**Right to make changes** — Philips Semiconductors reserves the right to make changes in the products—including circuits, standard cells, and/or software—described or contained herein in order to improve design and/or performance. When the product is in full production (status 'Production'), relevant changes will be communicated via a Customer Product/Process Change Notification (CPCN). Philips Semiconductors assumes no responsibility or liability for the use of any of these products, conveys no license or title under any patent, copyright, or mask work right to these products, and makes no representations or warranties that these products are free from patent, copyright, or mask work right infringement, unless otherwise specified.

## Contact information

For additional information please visit  
<http://www.semiconductors.philips.com>. Fax: +31 40 27 24825

© Koninklijke Philips Electronics N.V. 2003  
 All rights reserved. Printed in U.S.A.

Date of release: 06-03

For sales offices addresses send e-mail to:  
[sales.addresses@www.semiconductors.philips.com](mailto:sales.addresses@www.semiconductors.philips.com).

Document order number:

9397 750 11681

*Let's make things better.*



LittleDiode supplies new, hard to find or obsolete electronic components and semiconductors all over the world.

With over two million different components listed you are sure to find the part you need.

Feel free to visit us today at our online store:

[LittleDiode.com](http://LittleDiode.com)

Looking forward to providing you with the best possible service.