

DATA SHEET

For a complete data sheet, please also download:

- The IC04 LOCMOS HE4000B Logic Family Specifications HEF, HEC
- The IC04 LOCMOS HE4000B Logic Package Outlines/Information HEF, HEC

HEF4053B

MSI

Triple 2-channel analogue
multiplexer/demultiplexer

Product specification
File under Integrated Circuits, IC04

January 1995

Triple 2-channel analogue multiplexer/demultiplexer

HEF4053B MSI

DESCRIPTION

The HEF4053B is a triple 2-channel analogue multiplexer/demultiplexer with a common enable input (\bar{E}). Each multiplexer/demultiplexer has two independent inputs/outputs (Y_0 and Y_1), a common input/output (Z), and select inputs (S_n). Each also contains two-bidirectional analogue switches, each with one side connected to an independent input/output (Y_0 and Y_1) and the other side connected to a common input/output (Z).

With \bar{E} LOW, one of the two switches is selected (low impedance ON-state) by S_n . With \bar{E} HIGH, all switches are in the high impedance OFF-state, independent of S_A to S_C .

V_{DD} and V_{SS} are the supply voltage connections for the digital control inputs (S_A to S_C and \bar{E}).

The V_{DD} to V_{SS} range is 3 to 15 V. The analogue inputs/outputs (Y_0 , Y_1 and Z) can swing between V_{DD} as a positive limit and V_{EE} as a negative limit. $V_{DD}-V_{EE}$ may not exceed 15 V.

For operation as a digital multiplexer/demultiplexer, V_{EE} is connected to V_{SS} (typically ground).

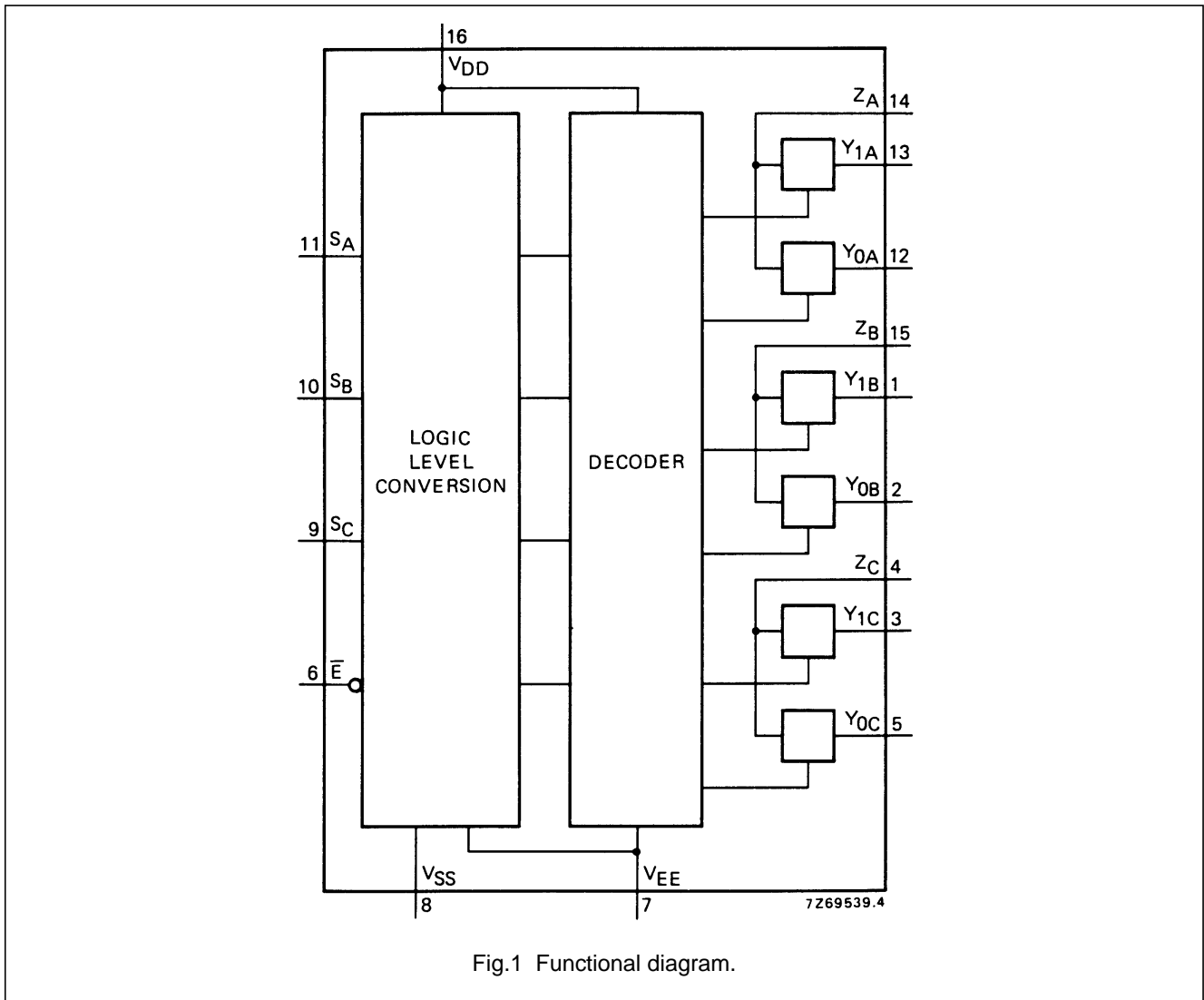

Fig.1 Functional diagram.

FAMILY DATA, I_{DD} LIMITS category MSI

See Family Specifications

Triple 2-channel analogue multiplexer/demultiplexer

HEF4053B
MSI

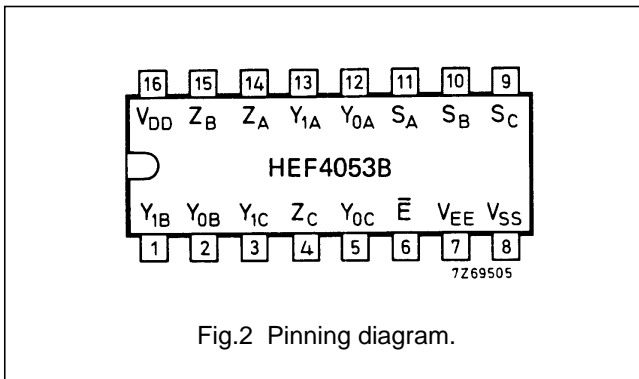

Fig.2 Pinning diagram.

PINNING

Y_{0A} to Y_{0C} independent inputs/outputs
 Y_{1A} to Y_{1C} independent inputs/outputs
 S_A to S_C select inputs
 \bar{E} enable input (active LOW)
 Z_A to Z_C common inputs/outputs

FUNCTION TABLE

INPUTS		CHANNEL ON
\bar{E}	S _n	
L	L	Y _{0n} -Z _n
L	H	Y _{1n} -Z _n
H	X	none

Notes

- H = HIGH state (the more positive voltage)
 L = LOW state (the less positive voltage)
 X = state is immaterial

HEF4053BP(N): 16-lead DIL; plastic (SOT38-1)

HEF4053BD(F): 16-lead DIL; ceramic (cerdip) (SOT74)

HEF4053BT(D): 16-lead SO; plastic (SOT109-1)

(): Package Designator North America

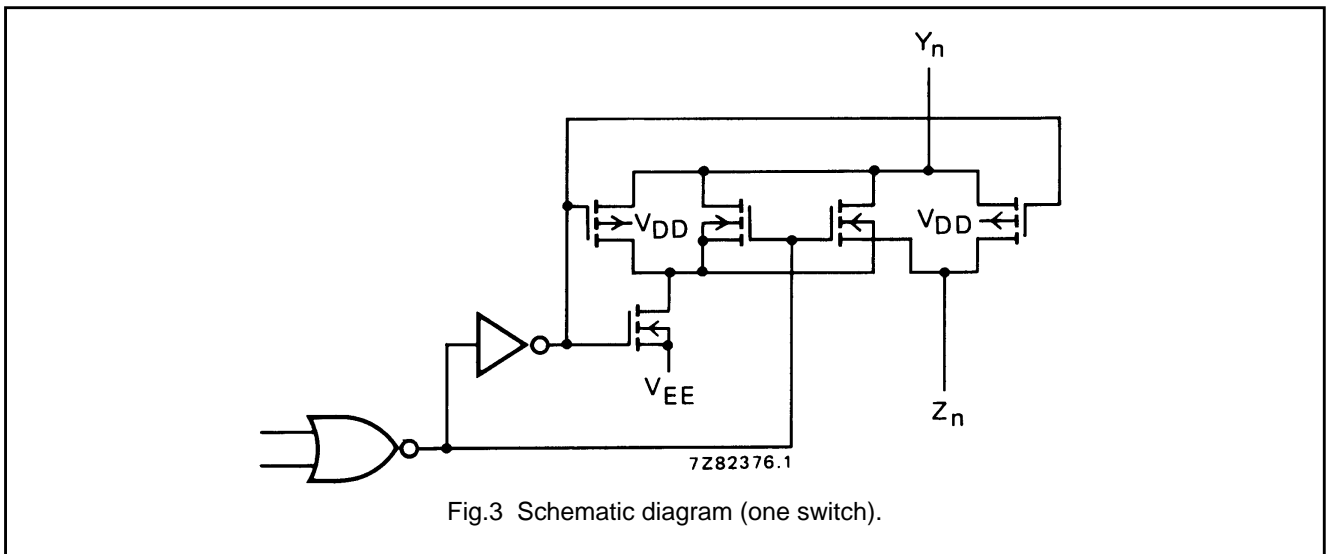

Fig.3 Schematic diagram (one switch).

RATINGS

Limiting values in accordance with the Absolute Maximum System (IEC 134)

Supply voltage (with reference to V_{DD}) V_{EE} -18 to +0,5 V

Note

- To avoid drawing V_{DD} current out of terminal Z, when switch current flows into terminals Y, the voltage drop across the bidirectional switch must not exceed 0,4 V. If the switch current flows into terminal Z, no V_{DD} current will flow out of terminals Y, in this case there is no limit for the voltage drop across the switch, but the voltages at Y and Z may not exceed V_{DD} or V_{EE}.

Triple 2-channel analogue
multiplexer/demultiplexer

HEF4053B
MSI

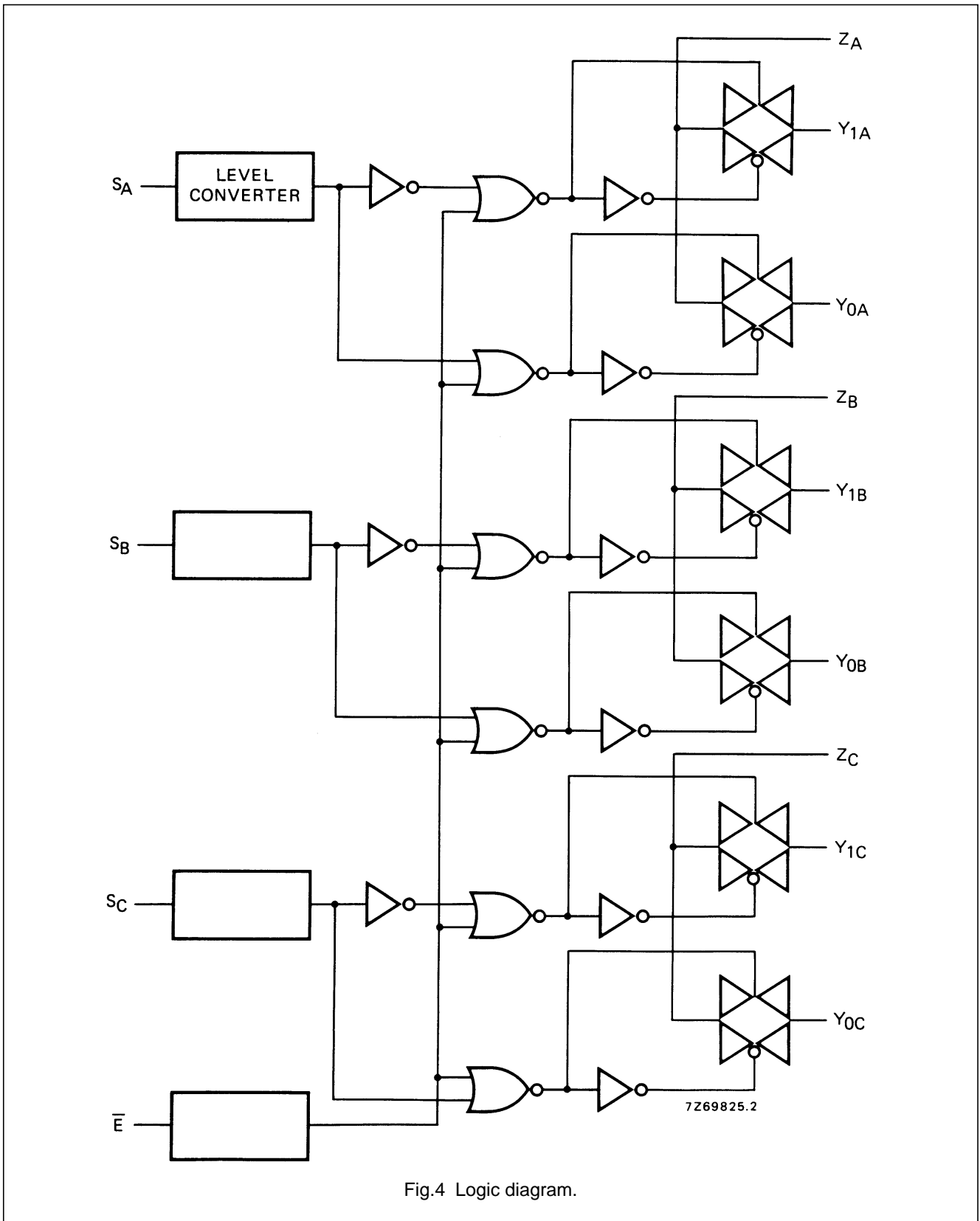

Fig.4 Logic diagram.

Triple 2-channel analogue
multiplexer/demultiplexer

HEF4053B
MSI

DC CHARACTERISTICS

T_{amb} = 25 °C

	V _{DD} -V _{EE} V	SYMBOL	TYP.	MAX.		CONDITIONS
ON resistance	5	R _{ON}	350	2500	Ω	V _{is} = 0 to V _{DD} -V _{EE} see Fig.6
	10		80	245	Ω	
	15		60	175	Ω	
ON resistance	5	R _{ON}	115	340	Ω	V _{is} = 0 see Fig.6
	10		50	160	Ω	
	15		40	115	Ω	
ON resistance	5	R _{ON}	120	365	Ω	V _{is} = V _{DD} -V _{EE} see Fig.6
	10		65	200	Ω	
	15		50	155	Ω	
'Δ' ON resistance between any two channels	5	ΔR _{ON}	25	-	Ω	V _{is} = 0 to V _{DD} -V _{EE} see Fig.6
	10		10	-	Ω	
	15		5	-	Ω	
OFF-state leakage current, all channels OFF	5	I _{oZZ}	-	-	nA	Ē at V _{DD}
	10		-	-	nA	
	15		-	1000	nA	
OFF-state leakage current, any channel	5	I _{oZY}	-	-	nA	Ē at V _{SS}
	10		-	-	nA	
	15		-	200	nA	

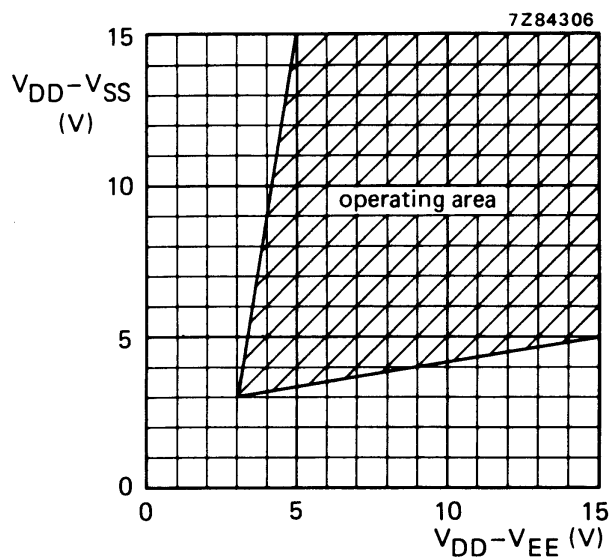

Fig.5 Operating area as a function of the supply voltages.

Triple 2-channel analogue
multiplexer/demultiplexer

HEF4053B
MSI

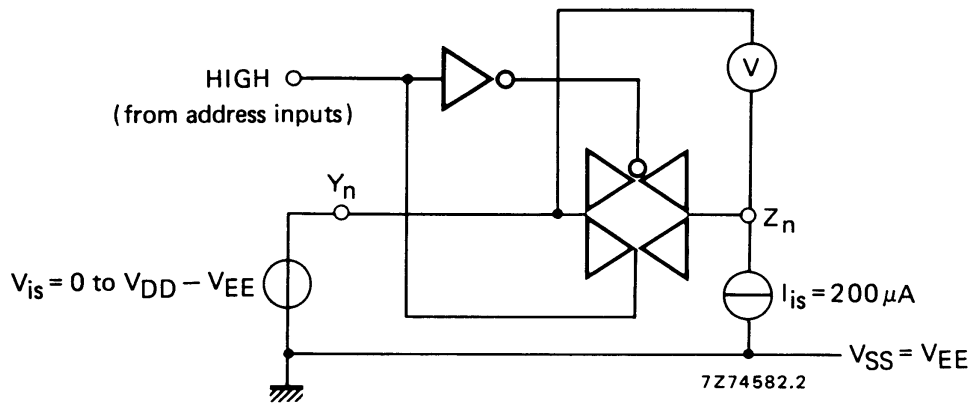
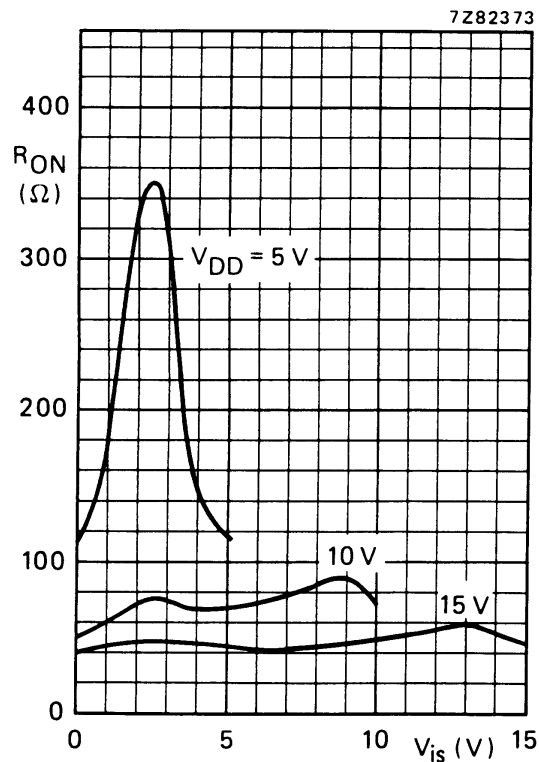

Fig.6 Test set-up for measuring R_{ON} .



$I_{is} = 200 \mu A$
 $V_{SS} = V_{EE} = 0 V$

Fig.7 Typical R_{ON} as a function of input voltage.

Triple 2-channel analogue multiplexer/demultiplexer

HEF4053B MSI

AC CHARACTERISTICS

 $V_{EE} = V_{SS} = 0 \text{ V}$; $T_{amb} = 25 \text{ }^\circ\text{C}$; input transition times $\leq 20 \text{ ns}$

	V_{DD} V	TYPICAL FORMULA FOR P (μW)	
Dynamic power dissipation per package (P)	5	$2\,500 f_i + \sum(f_o C_L) \times V_{DD}^2$	where f_i = input freq. (MHz) f_o = output freq. (MHz) C_L = load capacitance (pF) $\sum(f_o C_L)$ = sum of outputs V_{DD} = supply voltage (V)
	10	$11\,500 f_i + \sum(f_o C_L) \times V_{DD}^2$	
	15	$29\,000 f_i + \sum(f_o C_L) \times V_{DD}^2$	

AC CHARACTERISTICS

 $V_{EE} = V_{SS} = 0 \text{ V}$; $T_{amb} = 25 \text{ }^\circ\text{C}$; input transition times $\leq 20 \text{ ns}$

	V_{DD} V	SYMBOL	TYP.	MAX.			
Propagation delays $V_{is} \rightarrow V_{os}$ HIGH to LOW	5	t_{PHL}	10	20	ns	note 1	
	10		5	10	ns		
	15		5	10	ns		
	LOW to HIGH	5	t_{PLH}	15	30	ns	note 1
		10		5	10	ns	
		15		5	10	ns	
$S_n \rightarrow V_{os}$ HIGH to LOW	5	t_{PHL}	200	400	ns	note 2	
	10		85	170	ns		
	15		65	130	ns		
	LOW to HIGH	5	t_{PLH}	275	555	ns	note 2
		10		100	200	ns	
		15		65	130	ns	
Output disable times $\bar{E} \rightarrow V_{os}$ HIGH	5	t_{PHZ}	200	400	ns	note 3	
	10		115	230	ns		
	15		110	220	ns		
	LOW	5	t_{PLZ}	200	400	ns	note 3
		10		120	245	ns	
		15		110	215	ns	
Output enable times $\bar{E} \rightarrow V_{os}$ HIGH	5	t_{PZH}	260	525	ns	note 3	
	10		95	190	ns		
	15		65	130	ns		
	LOW	5	t_{PZL}	280	565	ns	note 3
		10		105	205	ns	
		15		70	140	ns	

Triple 2-channel analogue
multiplexer/demultiplexerHEF4053B
MSI

	V _{DD} V	SYMBOL	TYP.	MAX.	
Distortion, sine-wave response	5		0,25	%	note 4
	10		0,04	%	
	15		0,04	%	
Crosstalk between any two channels	5		–	MHz	note 5
	10		1	MHz	
	15		–	MHz	
Crosstalk; enable or address input to output	5		–	mV	note 6
	10		50	mV	
	15		–	mV	
OFF-state feed-through	5		–	MHz	note 7
	10		1	MHz	
	15		–	MHz	
ON-state frequency response	5		13	MHz	note 8
	10		40	MHz	
	15		70	MHz	

Notes

V_{is} is the input voltage at a Y or Z terminal, whichever is assigned as input.

V_{os} is the output voltage at a Y or Z terminal, whichever is assigned as output.

- R_L = 10 kΩ to V_{EE}; C_L = 50 pF to V_{EE}; \bar{E} = V_{SS}; V_{is} = V_{DD} (square-wave); see Fig.8.
- R_L = 10 kΩ; C_L = 50 pF to V_{EE}; \bar{E} = V_{SS}; S_n = V_{DD} (square-wave); V_{is} = V_{DD} and R_L to V_{EE} for t_{PLH}; V_{is} = V_{EE} and R_L to V_{DD} for t_{PHL}; see Fig.8.
- R_L = 10 kΩ; C_L = 50 pF to V_{EE}; \bar{E} = V_{DD} (square-wave);
V_{is} = V_{DD} and R_L to V_{EE} for t_{PHZ} and t_{PZH};
V_{is} = V_{EE} and R_L to V_{DD} for t_{PLZ} and t_{PZL}; see Fig.8.
- R_L = 10 kΩ; C_L = 15 pF; channel ON; V_{is} = 1/2 V_{DD (p-p)} (sine-wave, symmetrical about 1/2 V_{DD});
f_{is} = 1 kHz; see Fig.9.
- R_L = 1 kΩ; V_{is} = 1/2 V_{DD (p-p)} (sine-wave, symmetrical about 1/2 V_{DD});
 $20 \log \frac{V_{os}}{V_{is}} = -50 \text{ dB}$; see Fig. 10.
- R_L = 10 kΩ to V_{EE}; C_L = 15 pF to V_{EE}; \bar{E} or S_n = V_{DD} (square-wave); crosstalk is |V_{os}| (peak value); see Fig.8.
- R_L = 1 kΩ; C_L = 5 pF; channel OFF; V_{is} = 1/2 V_{DD (p-p)} (sine-wave, symmetrical about 1/2 V_{DD});
 $20 \log \frac{V_{os}}{V_{is}} = -50 \text{ dB}$; see Fig. 9.
- R_L = 1 kΩ; C_L = 5 pF; channel ON; V_{is} = 1/2 V_{DD (p-p)} (sine-wave, symmetrical about 1/2 V_{DD});
 $20 \log \frac{V_{os}}{V_{is}} = -3 \text{ dB}$; see Fig. 9.

Triple 2-channel analogue
multiplexer/demultiplexer

HEF4053B
MSI

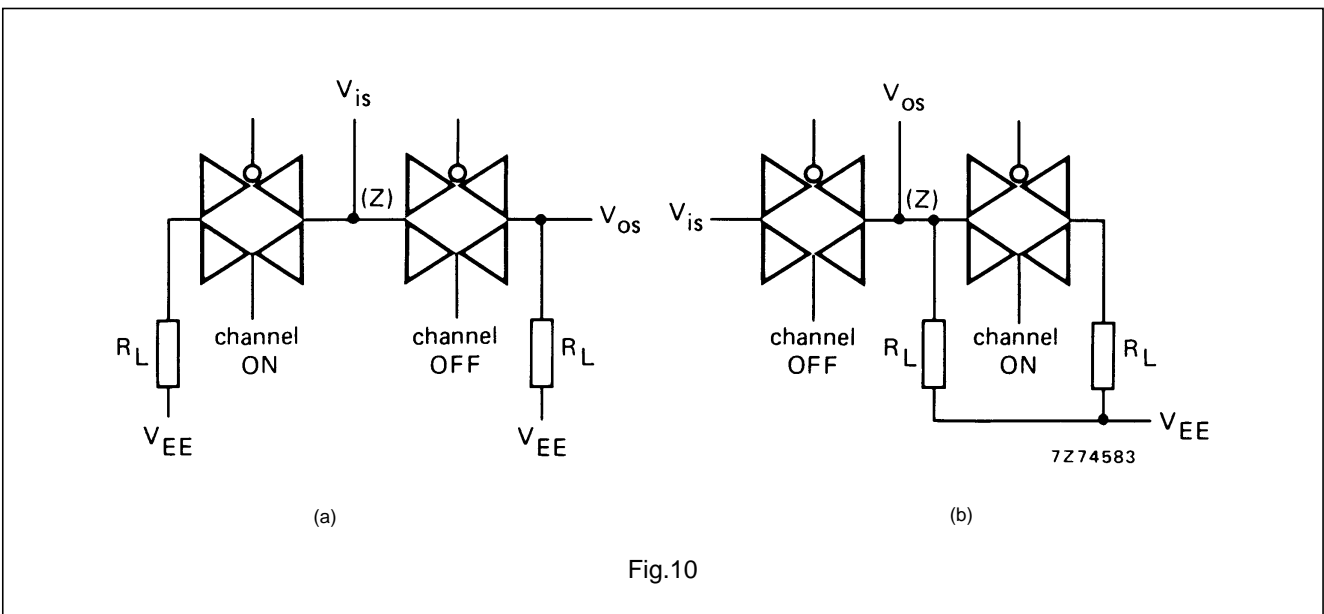
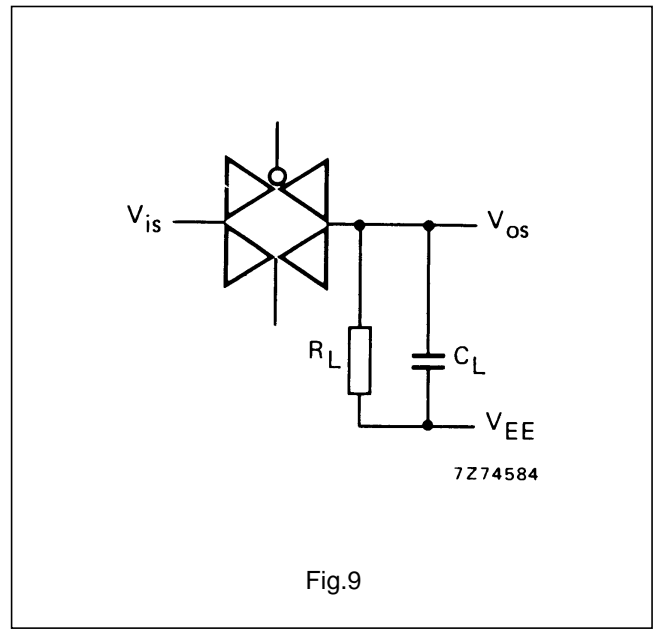
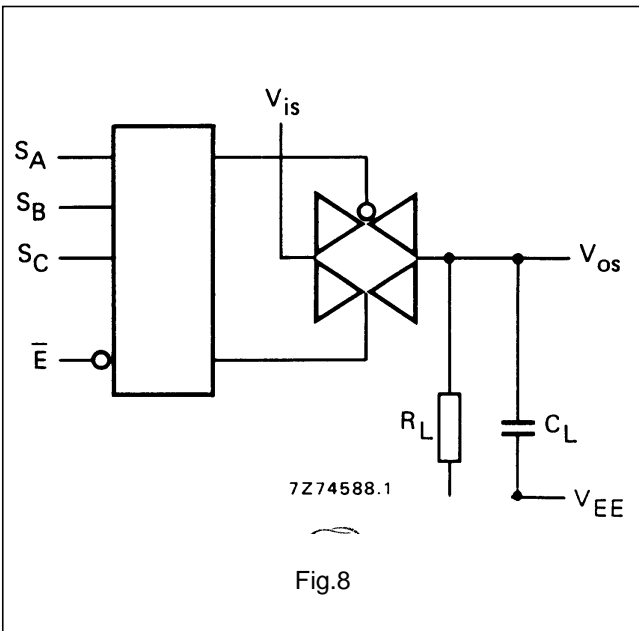

APPLICATION INFORMATION

Some examples of applications for the HEF4053B are:

- Analogue multiplexing and demultiplexing.
- Digital multiplexing and demultiplexing.
- Signal gating.

NOTE

If break before make is needed, then it is necessary to use the enable input.



LittleDiode supplies new, hard to find or obsolete electronic components and semiconductors all over the world.

With over two million different components listed you are sure to find the part you need.

Feel free to visit us today at our online store:

LittleDiode.com

Looking forward to providing you with the best possible service.