

CD4047BM/CD4047BC Low Power Monostable/Astable Multivibrator

General Description

CD4047B is capable of operating in either the monostable or astable mode. It requires an external capacitor (between pins 1 and 3) and an external resistor (between pins 2 and 3) to determine the output pulse width in the monostable mode, and the output frequency in the astable mode.

Astable operation is enabled by a high level on the astable input or low level on the astable input. The output frequency (at 50% duty cycle) at Q and \bar{Q} outputs is determined by the timing components. A frequency twice that of Q is available at the Oscillator Output; a 50% duty cycle is not guaranteed.

Monostable operation is obtained when the device is triggered by low-to-high transition at + trigger input or high-to-low transition at - trigger input. The device can be retriggered by applying a simultaneous low-to-high transition to both the + trigger and retrigger inputs.

A high level on Reset input resets the outputs Q to low, \bar{Q} to high.

Features

- Wide supply voltage range 3.0V to 15V
- High noise immunity 0.45 V_{DD} (typ.)
- Low power TTL compatibility Fan out of 2 driving 74L or 1 driving 74LS

SPECIAL FEATURES

- Low power consumption: special CMOS oscillator configuration
- Monostable (one-shot) or astable (free-running) operation
- True and complemented buffered outputs
- Only one external R and C required

MONOSTABLE MULTIVIBRATOR FEATURES

- Positive- or negative-edge trigger
- Output pulse width independent of trigger pulse duration
- Retriggerable option for pulse width expansion
- Long pulse widths possible using small RC components by means of external counter provision
- Fast recovery time essentially independent of pulse width
- Pulse-width accuracy maintained at duty cycles approaching 100%

ASTABLE MULTIVIBRATOR FEATURES

- Free-running or gatable operating modes
- 50% duty cycle
- Oscillator output available
- Good astable frequency stability
 - typical = $\pm 2\% + 0.03\%/^{\circ}\text{C}$ @ 100 kHz
 - frequency = $\pm 0.5\% + 0.015\%/^{\circ}\text{C}$ @ 10 kHz
 - deviation (circuits trimmed to frequency $V_{DD} = 10V \pm 10\%$)

Applications

- Frequency discriminators
- Timing circuits
- Time-delay applications
- Envelope detection
- Frequency multiplication
- Frequency division

Block and Connection Diagrams

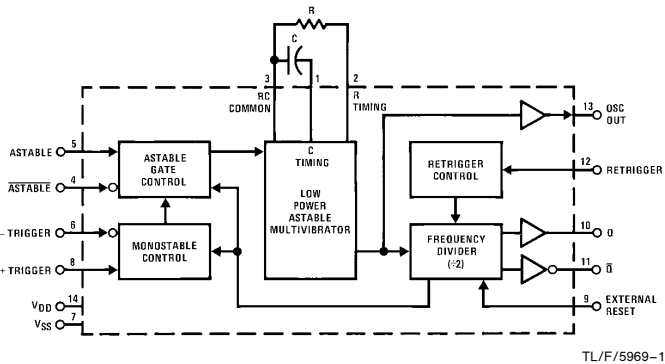

Dual-In-Line Package

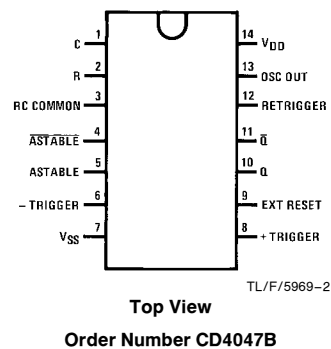

CD4047BM/CD4047BC Low Power Monostable/Astable Multivibrator

Absolute Maximum Ratings (Notes 1 and 2)

If Military/Aerospace specified devices are required, please contact the National Semiconductor Sales Office/Distributors for availability and specifications.

DC Supply Voltage (V_{DD})	-0.5V to +18V _{DC}
Input Voltage (V_{IN})	-0.5V to V_{DD} + 0.5V _{DC}
Storage Temperature Range (T_S)	-65°C to +150°C
Power Dissipation (P_D)	
Dual-In-Line	700 mW
Small Outline	500 mW
Lead Temperature (T_L)	
(Soldering, 10 seconds)	260°C

Recommended Operating Conditions (Note 2)

DC Supply Voltage (V_{DD})	3V to 15V _{DC}
Input Voltage (V_{IN})	0 to V_{DD} V _{DC}
Operating Temperature Range (T_A)	
CD4047BM	-55°C to +125°C
CD4047BC	-40°C to +85°C

DC Electrical Characteristics CD4047BM (Note 2)

Symbol	Parameter	Conditions	-55°C		25°C			125°C		Units
			Min	Max	Min	Typ	Max	Min	Max	
I_{DD}	Quiescent Device Current	$V_{DD} = 5V$		5			5		150	μA
		$V_{DD} = 10V$		10			10		300	μA
		$V_{DD} = 15V$		20			20		600	μA
V_{OL}	Low Level Output Voltage	$ I_O < 1 \mu A$								
		$V_{DD} = 5V$		0.05		0	0.05		0.05	V
		$V_{DD} = 10V$		0.05		0	0.05		0.05	V
V_{OH}	High Level Output Voltage	$ I_O < 1 \mu A$								
		$V_{DD} = 5V$	4.95		4.95	5		4.95		V
		$V_{DD} = 10V$	9.95		9.95	10		9.95		V
V_{IL}	Low Level Input Voltage	$V_{DD} = 5V, V_O = 0.5V$ or 4.5V		1.5		2.25	1.5		1.5	V
		$V_{DD} = 10V, V_O = 1V$ or 9V		3.0		4.5	3.0		3.0	V
		$V_{DD} = 15V, V_O = 1.5V$ or 13.5V		4.0		6.75	4.0		4.0	V
V_{IH}	High Level Input Voltage	$V_{DD} = 5V, V_O = 0.5V$ or 4.5V	3.5		3.5	2.75		3.5		V
		$V_{DD} = 10V, V_O = 1V$ or 9V	7.0		7.0	5.5		7.0		V
		$V_{DD} = 15V, V_O = 1.5V$ or 13.5V	11.0		11.0	8.25		11.0		V
I_{OL}	Low Level Output Current (Note 3)	$V_{DD} = 5V, V_O = 0.4V$	0.64		0.51	0.88		0.36		mA
		$V_{DD} = 10V, V_O = 0.5V$	1.6		1.3	2.25		0.9		mA
		$V_{DD} = 15V, V_O = 1.5V$	4.2		3.4	8.8		2.4		mA
I_{OH}	High Level Output Current (Note 3)	$V_{DD} = 5V, V_O = 4.6V$	-0.64		-0.51	-0.88		-0.36		mA
		$V_{DD} = 10V, V_O = 9.5V$	-1.6		-1.3	-2.25		-0.9		mA
		$V_{DD} = 15V, V_O = 13.5V$	-4.2		-3.4	-8.8		-2.4		mA
I_{IN}	Input Current	$V_{DD} = 15V, V_{IN} = 0V$		-0.1		-10^{-5}	-0.1		-1.0	μA
		$V_{DD} = 15V, V_{IN} = 15V$		0.1		10^{-5}	0.1		1.0	μA

DC Electrical Characteristics CD4047BC (Note 2)

Symbol	Parameter	Conditions	-40°C		25°C			85°C		Units
			Min	Max	Min	Typ	Max	Min	Max	
I_{DD}	Quiescent Device Current	$V_{DD} = 5V$		20			20		150	μA
		$V_{DD} = 10V$		40			40		300	μA
		$V_{DD} = 15V$		80			80		600	μA
V_{OL}	Low Level Output Voltage	$ I_O < 1 \mu A$								
		$V_{DD} = 5V$		0.05		0	0.05		0.05	V
		$V_{DD} = 10V$		0.05		0	0.05		0.05	V
V_{OH}	High Level Output Voltage	$ I_O < 1 \mu A$								
		$V_{DD} = 5V$	4.95		4.95	5		4.95		V
		$V_{DD} = 10V$	9.95		9.95	10		9.95		V
V_{OH}	High Level Output Voltage	$V_{DD} = 15V$	14.95		14.95	15		14.95		V

DC Electrical Characteristics CD4047BC (Note 2) (Continued)

Symbol	Parameter	Conditions	-40°C		25°C			85°C		Units
			Min	Max	Min	Typ	Max	Min	Max	
V _{IL}	Low Level Input Voltage	V _{DD} = 5V, V _O = 0.5V or 4.5V		1.5		2.25	1.5		1.5	V
		V _{DD} = 10V, V _O = 1V or 9V		3.0		4.5	3.0		3.0	V
		V _{DD} = 15V, V _O = 1.5V or 13.5V		4.0		6.75	4.0		4.0	V
V _{IH}	High Level Input Voltage	V _{DD} = 5V, V _O = 0.5V or 4.5V	3.5		3.5	2.75		3.5		V
		V _{DD} = 10V, V _O = 1V or 9V	7.0		7.0	5.5		7.0		V
		V _{DD} = 15V, V _O = 1.5V or 13.5V	11.0		11.0	8.25		11.0		V
I _{OL}	Low Level Output Current (Note 3)	V _{DD} = 5V, V _O = 0.4V	0.52		0.44	0.88		0.36		mA
		V _{DD} = 10V, V _O = 0.5V	1.3		1.1	2.25		0.9		mA
		V _{DD} = 15V, V _O = 1.5V	3.6		3.0	8.8		2.4		mA
I _{OH}	High Level Output Current (Note 3)	V _{DD} = 5V, V _O = 4.6V	-0.52		-0.44	-0.88		-0.36		mA
		V _{DD} = 10V, V _O = 9.5V	-1.3		-1.1	-2.25		-0.9		mA
		V _{DD} = 15V, V _O = 13.5V	-3.6		-3.0	-8.8		-2.4		mA
I _{IN}	Input Current	V _{DD} = 15V, V _{IN} = 0V		-0.3		-10 ⁻⁵	-0.3		-1.0	μA
		V _{DD} = 15V, V _{IN} = 15V		0.3		10 ⁻⁵	0.3		1.0	μA

Note 1: "Absolute Maximum Ratings" are those values beyond which the safety of the device cannot be guaranteed. They are not meant to imply that the devices should be operated at these limits. The table of "Recommended Operating Conditions" and "Electrical Characteristics" provides conditions for actual device operation.

Note 2: V_{SS} = 0V unless otherwise specified.

Note 3: I_{OH} and I_{OL} are tested one output at a time.

AC Electrical Characteristics* CD4047B

T_A = 25°C, C_L = 50 pF, R_L = 200k, input t_r = t_f = 20 ns, unless otherwise specified.

Symbol	Parameter	Conditions	Min	Typ	Max	Units
t _{PHL} , t _{PLH}	Propagation Delay Time Astable, Astable to Osc Out	V _{DD} = 5V		200	400	ns
		V _{DD} = 10V		100	200	ns
		V _{DD} = 15V		80	160	ns
t _{PHL} , t _{PLH}	Astable, Astable to Q, \bar{Q}	V _{DD} = 5V		550	900	ns
		V _{DD} = 10V		250	500	ns
		V _{DD} = 15V		200	400	ns
t _{PHL} , t _{PLH}	+ Trigger, - Trigger to \bar{Q}	V _{DD} = 5V		700	1200	ns
		V _{DD} = 10V		300	600	ns
		V _{DD} = 15V		240	480	ns
t _{PHL} , t _{PLH}	+ Trigger, Retrigger to \bar{Q}	V _{DD} = 5V		300	600	ns
		V _{DD} = 10V		175	300	ns
		V _{DD} = 15V		150	250	ns
t _{PHL} , t _{PLH}	Reset to Q, \bar{Q}	V _{DD} = 5V		300	600	ns
		V _{DD} = 10V		125	250	ns
		V _{DD} = 15V		100	200	ns
t _{THL} , t _{TLH}	Transition Time Q, \bar{Q} , Osc Out	V _{DD} = 5V		100	200	ns
		V _{DD} = 10V		50	100	ns
		V _{DD} = 15V		40	80	ns
t _{WL} , t _{WH}	Minimum Input Pulse Duration	Any Input				
		V _{DD} = 5V		500	1000	ns
		V _{DD} = 10V		200	400	ns
t _{RCL} , t _{FCL}	+ Trigger, Retrigger, Rise and Fall Time	V _{DD} = 5V			15	μs
		V _{DD} = 10V			5	μs
		V _{DD} = 15V			5	μs
C _{IN}	Average Input Capacitance	Any Input		5	7.5	pF

*AC Parameters are guaranteed by DC correlated testing.

Logic Diagram

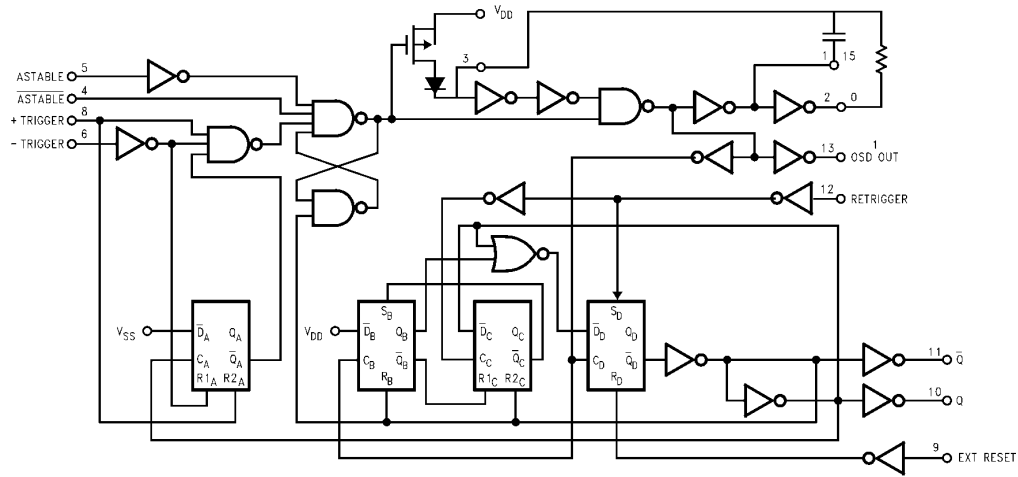

TL/F/5969-3

*Special input protection circuit to permit larger input-voltage swings.

Truth Table

Function	Terminal Connections			Output Pulse From	Typical Output Period or Pulse Width
	To V _{DD}	To V _{SS}	Input Pulse To		
Astable Multivibrator					
Free-Running	4, 5, 6, 14	7, 8, 9, 12		10, 11, 13	$t_A(10, 11) = 4.40 RC$
True Gating	4, 6, 14	7, 8, 9, 12	5	10, 11, 13	$t_A(13) = 2.20 RC$
Complement Gating	6, 14	5, 7, 8, 9, 12	4	10, 11, 13	
Monostable Multivibrator					
Positive-Edge Trigger	4, 14	5, 6, 7, 9, 12	8	10, 11	$t_M(10, 11) = 2.48 RC$
Negative-Edge Trigger	4, 8, 14	5, 7, 9, 12	6	10, 11	
Retriggerable	4, 14	5, 6, 7, 9	8, 12	10, 11	
External Countdown*	14	5, 6, 7, 8, 9, 12	(See Figure)	(See Figure)	(See Figure)

Note: External resistor between terminals 2 and 3. External capacitor between terminals 1 and 3.

*Typical Implementation of External Countdown Option

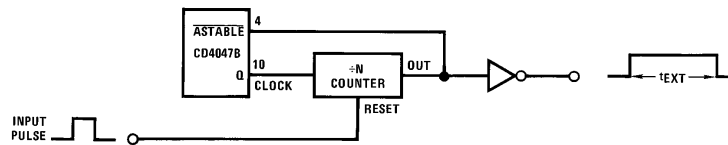

$$t_{EXT} = (N - 1) t_A + (t_M + t_A/2)$$

TL/F/5969-4

Typical Performance Characteristics

Typical Q, \bar{Q} , Osc Out Period Accuracy vs Supply Voltage (Astable Mode Operation)

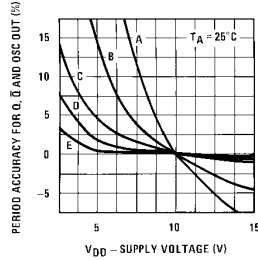

TL/F/5969-5

Typical Q, \bar{Q} , Pulse Width Accuracy vs Supply Voltage Monostable Mode Operation

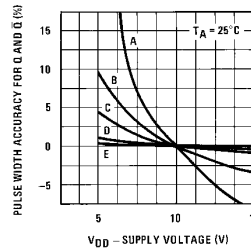

TL/F/5969-6

	$f_{Q, \bar{Q}}$	R	C
A	1000 kHz	22k	10 pF
B	100 kHz	22k	100 pF
C	10 kHz	220k	100 pF
D	1 kHz	220k	1000 pF
E	100 Hz	2.2M	1000 pF

	t_M	R	C
A	2 μ s	22k	10 pF
B	7 μ s	22k	100 pF
C	60 μ s	220k	100 pF
D	550 μ s	220k	1000 pF
E	5.5 ms	2.2M	1000 pF

Typical Q, \bar{Q} and Osc Out Period Accuracy vs Temperature Astable Mode Operation

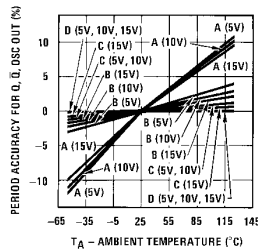

TL/F/5969-7

Typical Q and \bar{Q} Pulse Width Accuracy vs Temperature Monostable Mode Operation

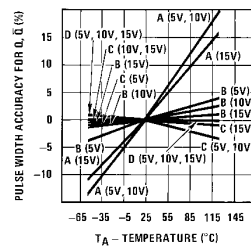

TL/F/5969-8

	$f_{Q, \bar{Q}}$	R	C
A	1000 kHz	22k	10 pF
B	100 kHz	22k	100 pF
C	10 kHz	220k	100 pF
D	1 kHz	220k	1000 pF

	t_M	R	C
A	2 μ s	22k	10 pF
B	7 μ s	22k	100 pF
C	60 μ s	220k	100 pF
D	550 μ s	220k	1000 pF

Timing Diagram

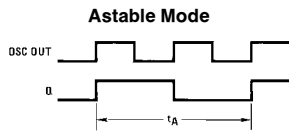

TL/F/5969-9

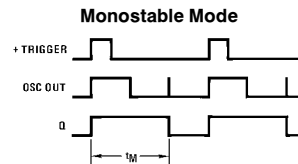

TL/F/5969-10

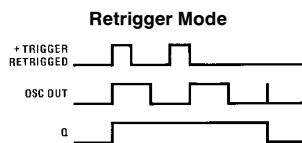

TL/F/5969-11

Physical Dimensions inches (millimeters)

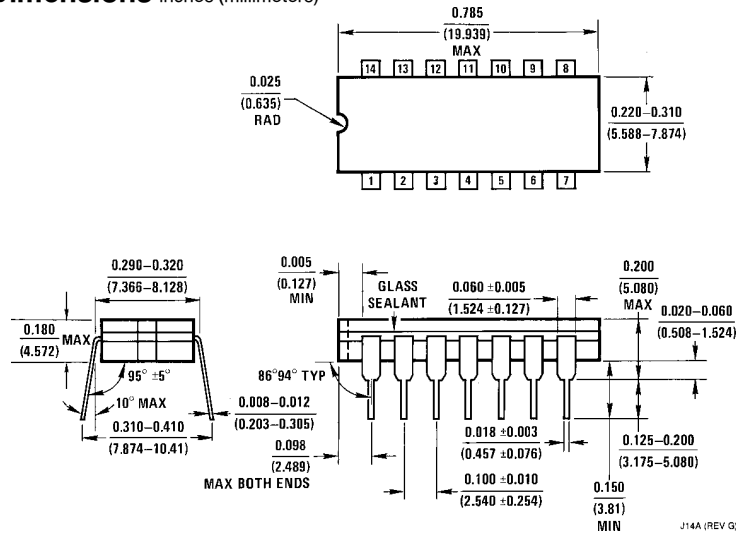

Order Number CD4047BMJ or CD4047BCJ
NS Package Number J14A

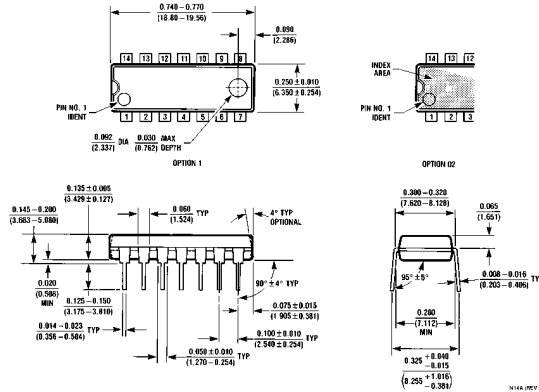

Order Number CD4047BMN or CD4047BCN
NS Package Number N14A

LIFE SUPPORT POLICY

NATIONAL'S PRODUCTS ARE NOT AUTHORIZED FOR USE AS CRITICAL COMPONENTS IN LIFE SUPPORT DEVICES OR SYSTEMS WITHOUT THE EXPRESS WRITTEN APPROVAL OF THE PRESIDENT OF NATIONAL SEMICONDUCTOR CORPORATION. As used herein:

1. Life support devices or systems are devices or systems which, (a) are intended for surgical implant into the body, or (b) support or sustain life, and whose failure to perform, when properly used in accordance with instructions for use provided in the labeling, can be reasonably expected to result in a significant injury to the user.
2. A critical component is any component of a life support device or system whose failure to perform can be reasonably expected to cause the failure of the life support device or system, or to affect its safety or effectiveness.



National Semiconductor Corporation
1111 West Bardin Road
Arlington, TX 76017
Tel: 1(800) 272-9959
Fax: 1(800) 737-7018

National Semiconductor Europe
Fax: (+49) 0-180-530 85 86
Email: cnjwge@tevm2.nsc.com
Deutsch Tel: (+49) 0-180-530 85 85
English Tel: (+49) 0-180-532 78 32
Français Tel: (+49) 0-180-532 93 58
Italiano Tel: (+49) 0-180-534 16 80

National Semiconductor Hong Kong Ltd.
19th Floor, Straight Block,
Ocean Centre, 5 Canton Rd.
Tsimshatsui, Kowloon
Hong Kong
Tel: (852) 2737-1600
Fax: (852) 2736-9960

National Semiconductor Japan Ltd.
Tel: 81-043-299-2309
Fax: 81-043-299-2408

National does not assume any responsibility for use of any circuitry described, no circuit patent licenses are implied and National reserves the right at any time without notice to change said circuitry and specifications.

National Semiconductor was acquired by Texas Instruments.

http://www.ti.com/corp/docs/investor_relations/pr_09_23_2011_national_semiconductor.html

This file is the datasheet for the following electronic components:

CD4047BM - <http://www.ti.com/product/cd4047bm?HQS=TI-null-null-dscatalog-df-pf-null-ww>

CD4047BC - <http://www.ti.com/product/cd4047bc?HQS=TI-null-null-dscatalog-df-pf-null-ww>



LittleDiode supplies new, hard to find or obsolete electronic components and semiconductors all over the world.

With over two million different components listed you are sure to find the part you need.

Feel free to visit us today at our online store:

LittleDiode.com

Looking forward to providing you with the best possible service.