

**ADJUSTABLE PRECISION SHUNT REGULATORS**

**Description**

The AS431 is a three-terminal adjustable shunt regulator with guaranteed thermal stability over a full operation range. It features sharp turn-on characteristics, low temperature coefficient and low output impedance, which make it ideal substitute for Zener diode in applications such as switching power supply, charger and other adjustable regulators.

The output voltage of AS431 can be set to any value between VREF (2.5V) and the corresponding maximum cathode voltage (36V).

The AS431 precision reference is offered in two voltage tolerance: 0.5% and 1.0%.

This IC is available in 4 packages: TO-92 (bulk or ammo packing), SOT-23, SOT-23-5 and SOT-89.

**Features**

- Programmable Precise Output Voltage from 2.5V to 36V
- High Stability under Capacitive Load
- Low Temperature Deviation: 4.5mV Typical
- Low Equivalent Full-range Temperature Coefficient with 20PPM/°C Typical
- Sink Current Capacity from 1mA to 100mA
- Low Output Noise
- Wide Operating Range of -40 to +125°C
- Lead-Free Packages: SOT-23, SOT-23-5, TO-92, SOT-89
  - **Totally Lead-Free; RoHS Compliant (Notes 1 & 2)**
- Lead-Free Packages, Available in "Green" Molding Compound: SOT-23, SOT-23-5, TO-92, SOT-89
  - **Totally Lead-Free & Fully RoHS Compliant (Notes 1 & 2)**
  - **Halogen and Antimony Free. "Green" Device (Note 3)**

**Applications**

- Charger
- Voltage Adapter
- Switching Power Supply
- Graphic Card
- Precision Voltage Reference

Notes: 1. No purposely added lead. Fully EU Directive 2002/95/EC (RoHS) & 2011/65/EU (RoHS 2) compliant.  
 2. See [http://www.diodes.com/quality/lead\\_free.html](http://www.diodes.com/quality/lead_free.html) for more information about Diodes Incorporated's definitions of Halogen- and Antimony-free, "Green" and Lead-free.  
 3. Halogen- and Antimony-free "Green" products are defined as those which contain <900ppm bromine, <900ppm chlorine (<1500ppm total Br + Cl) and <1000ppm antimony compounds.

**Pin Assignments**

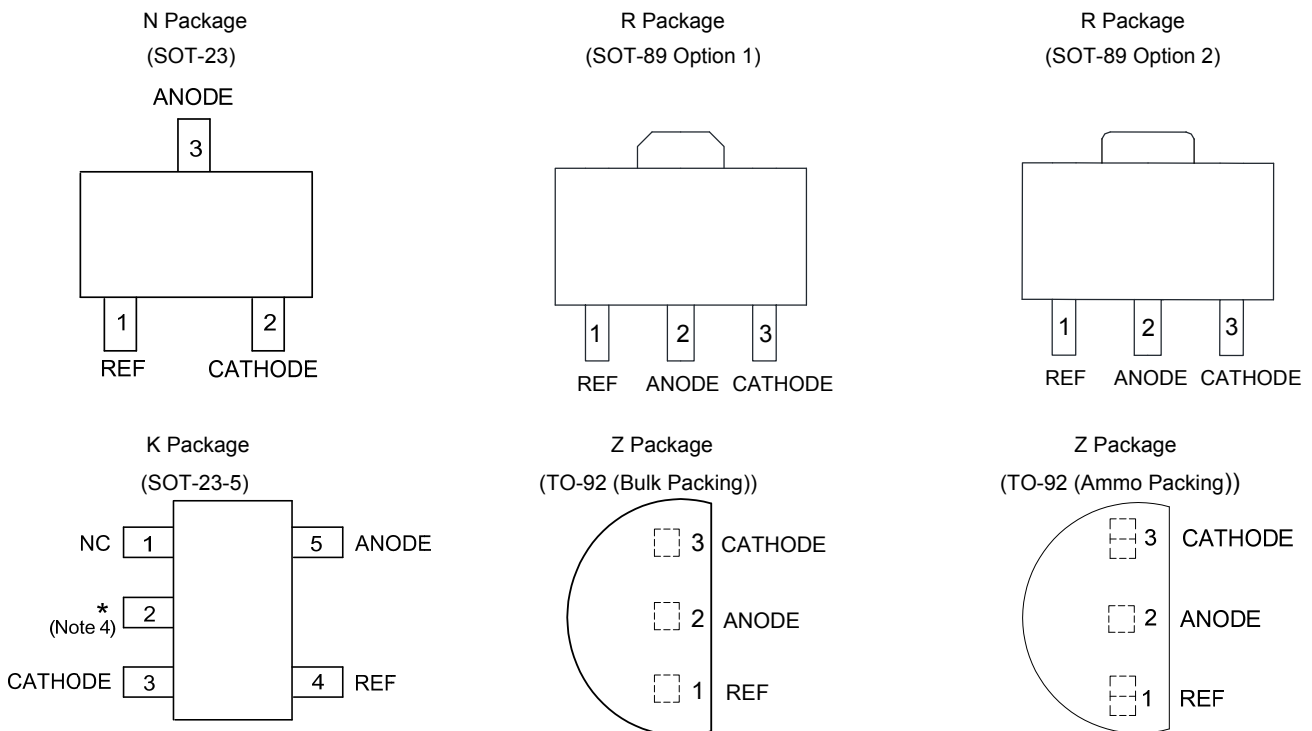

Note: 4. \* Pin 2 is attached to substrate and must be connected to ANODE or open.

**Typical Applications Circuit**

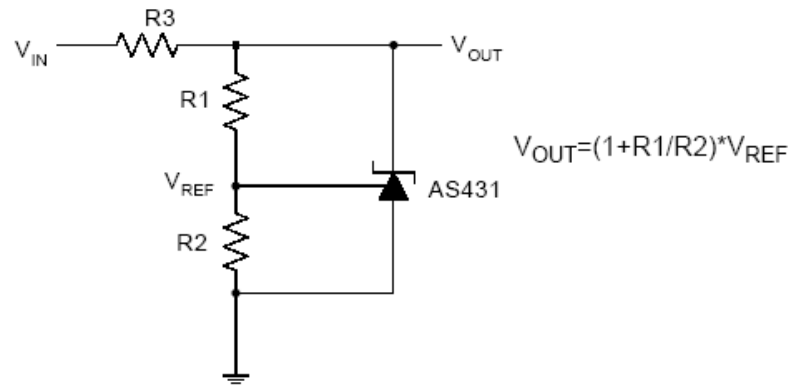

Shunt Regulator

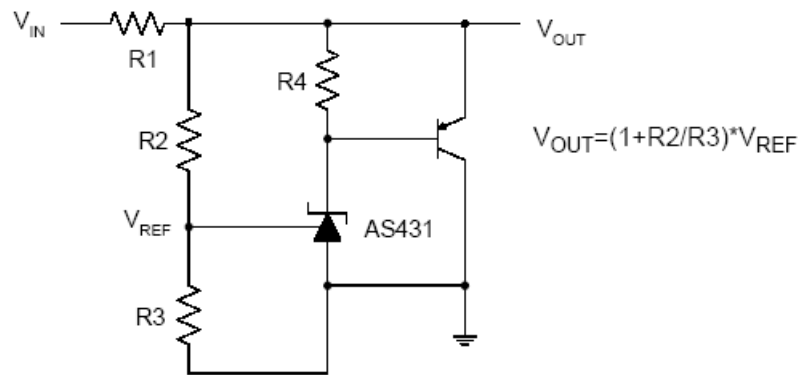

High Current Shunt Regulator

**Typical Applications Circuit (Cont.)**

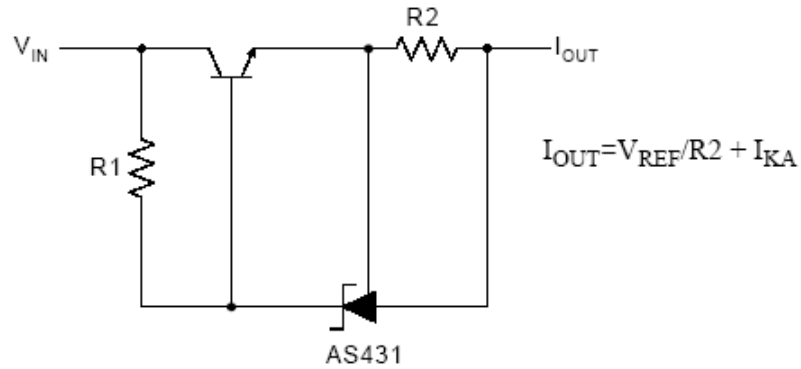

Current Source or Current Limit

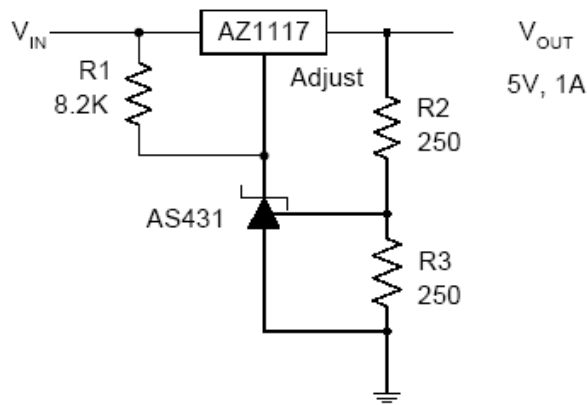

Precision 5V 1A Regulator

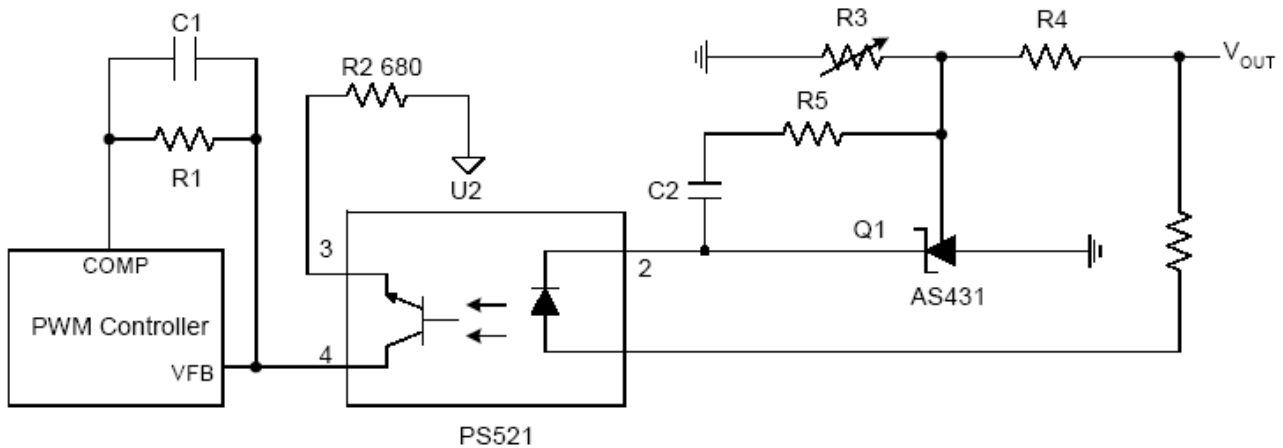

PWM Converter with Reference

## Functional Block Diagram

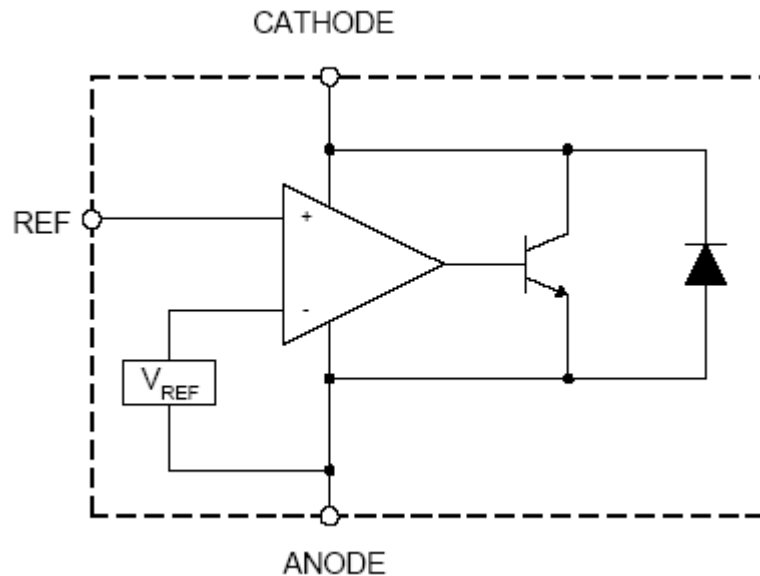

## Absolute Maximum Ratings (Note 5)

Symbol	Parameter	Rating		Unit
$V_{KA}$	Cathode Voltage	40		V
$I_{KA}$	Cathode Current Range (Continuous)	-100 to 150		mA
$I_{REF}$	Reference Input Current Range	10		mA
$P_D$	Power Dissipation	Z, R Package	770	mW
		N, K Package	370	
$T_J$	Junction Temperature	+150		°C
$T_{STG}$	Storage Temperature Range	-65 to +150		°C
ESD	ESD (Human Body Model)	2000		V

Note 5: Stresses greater than those listed under "Absolute Maximum Ratings" may cause permanent damage to the device. These are stress ratings only, and functional operation of the device at these or any other conditions beyond those indicated under "Recommended Operating Conditions" is not implied. Exposure to "Absolute Maximum Ratings" for extended periods may affect device reliability.

## Recommended Operating Conditions

Symbol	Parameter	Min	Max	Unit
$V_{KA}$	Cathode Voltage	$V_{REF}$	36	V
$I_{KA}$	Cathode Current	1.0	100	mA
$T_A$	Operating Ambient Temperature Range	-40	+125	°C

**Electrical Characteristics** (Operating Conditions:  $T_A = +25^\circ\text{C}$ , unless otherwise specified.)

Symbol	Parameter	Test Circuit	Conditions	Min	Typ	Max	Unit	
$V_{REF}$	Reference Voltage	4	$V_{KA} = V_{REF}, I_{KA} = 10\text{mA}$	0.5%	2.487	2.500	2.512	V
				1.0%	2.475	2.500	2.525	
$\Delta V_{REF}$	Deviation of Reference Voltage Over Full Temperature Range	4	$V_{KA} = V_{REF}, I_{KA} = 10\text{mA}$	0 to $+70^\circ\text{C}$	-	4.5	8	mV
				$-40$ to $+85^\circ\text{C}$	-	4.5	10	
				$-40$ to $+125^\circ\text{C}$	-	4.5	16	
$\frac{\Delta V_{REF}}{\Delta V_{KA}}$	Ratio of Change in Reference Voltage to the Change in Cathode Voltage	5	$I_{KA} = 10\text{mA}$	$\Delta V_{KA} = 10\text{V to } V_{REF}$	-	-1.0	-2.7	mV/V
				$\Delta V_{KA} = 36\text{V to } 10\text{V}$	-	-0.5	-2.0	
$I_{REF}$	Reference Current	5	$I_{KA} = 10\text{mA}, R1 = 10\text{K}\Omega, R2 = \infty$	-	0.7	4	$\mu\text{A}$	
$\Delta I_{REF}$	Deviation of Reference Current Over Full Temperature Range	5	$I_{KA} = 10\text{mA}, R1 = 10\text{K}\Omega, R2 = \infty, T_A = -40$ to $+125^\circ\text{C}$	-	0.4	1.2	$\mu\text{A}$	
$I_{KA}$ (Min)	Minimum Cathode Current for Regulation	4	$V_{KA} = V_{REF}$	-	0.4	1.0	mA	
$I_{KA}$ (Off)	Off-state Cathode Current	6	$V_{KA} = 36\text{V}, V_{REF} = 0$	-	0.05	1.0	$\mu\text{A}$	
$Z_{KA}$	Dynamic Impedance	4	$V_{KA} = V_{REF}, I_{KA} = 1$ to $100\text{mA}, f \leq 1.0\text{KHz}$	-	0.15	0.5	$\Omega$	
$\theta_{JC}$	Thermal Resistance	-	SOT-23	-	135.9	-	$^\circ\text{C/W}$	
			SOT-23-5	-	135.9	-		
			TO-92	-	81.9	-		
			SOT-89	-	29.8	-		

**Electrical Characteristics** (Cont.)

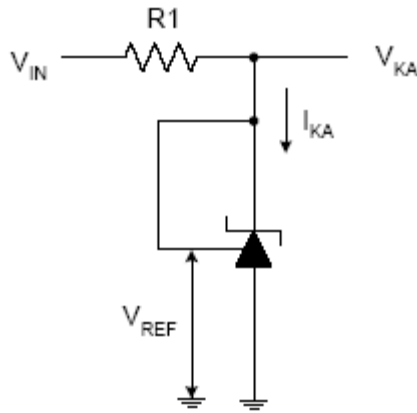

Test Circuit 4 for  $V_{KA} = V_{REF}$

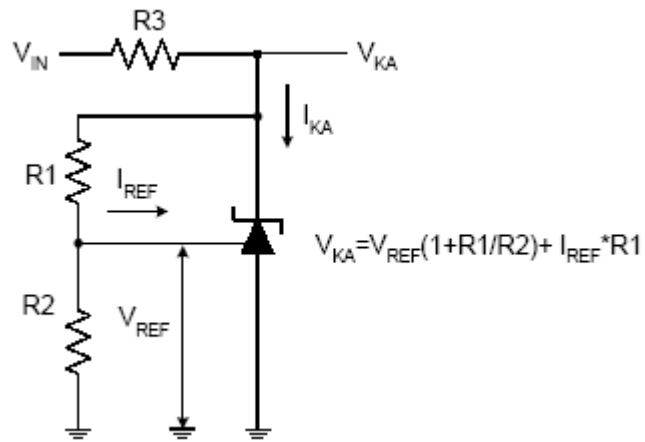

Test Circuit 5 for  $V_{KA} > V_{REF}$

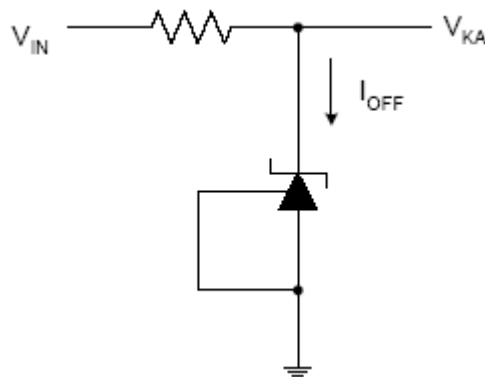

Test Circuit 6 for  $I_{OFF}$

**Performance Characteristics**

**Reference Voltage vs. Ambient Temperature**

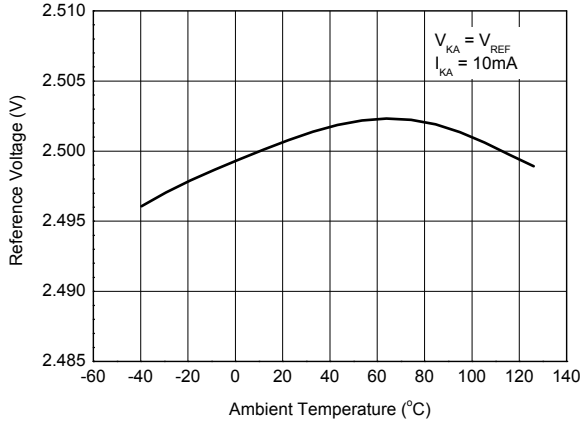

**Reference Current vs. Ambient Temperature**

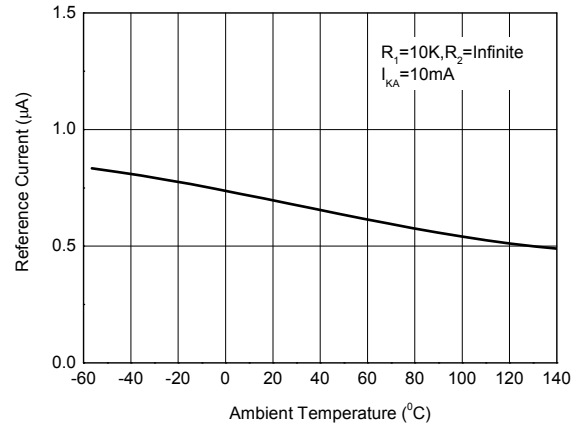

**Cathode Current vs. Cathode Voltage**

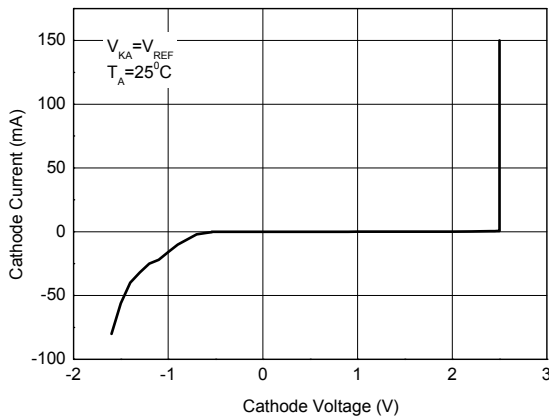

**Cathode Current vs. Cathode Voltage**

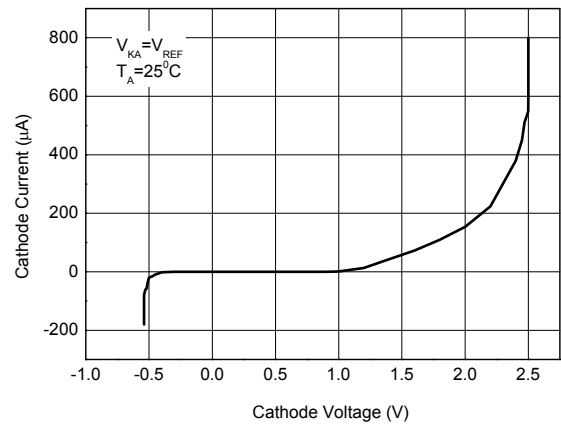

**Off-State Cathode Current vs. Ambient Temperature**

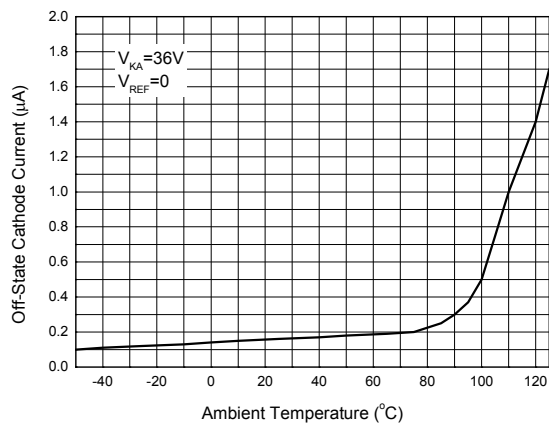

**Ratio of Delta Reference Voltage to the Ratio of Delta Cathode Voltage**

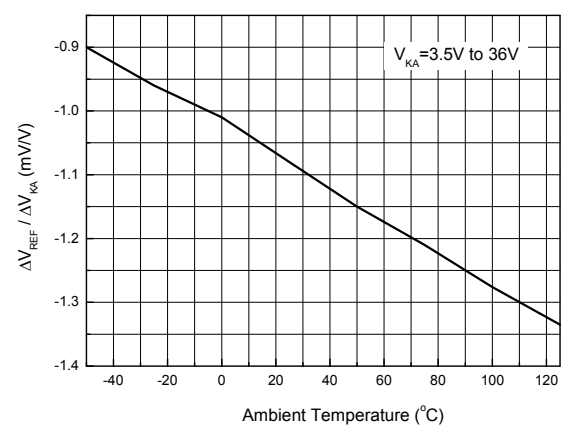

**Performance Characteristics (Cont.)**

**Small Signal Voltage Gain vs. Frequency**

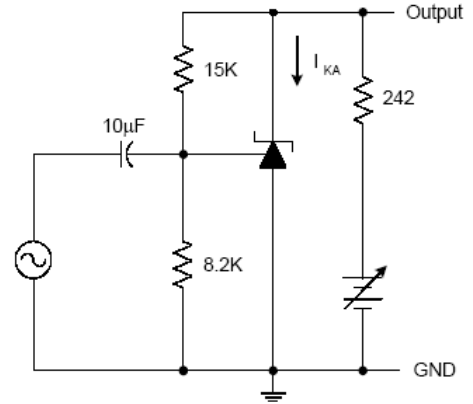
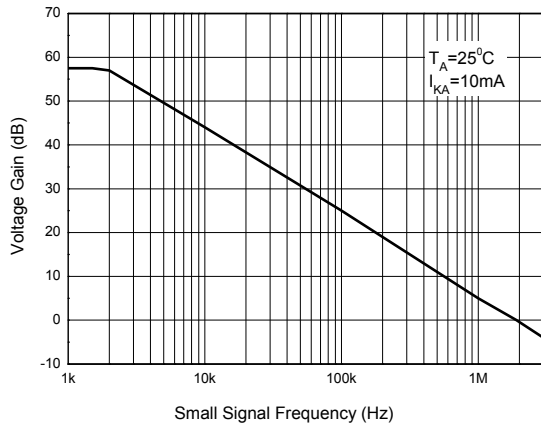

**Reference Impedance vs. Frequency**

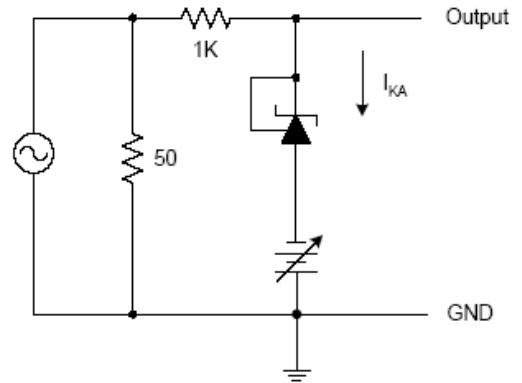
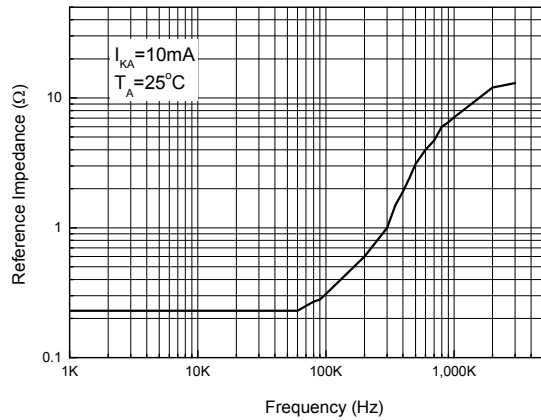

**Stability Boundary Conditions vs. Load Capacitance**

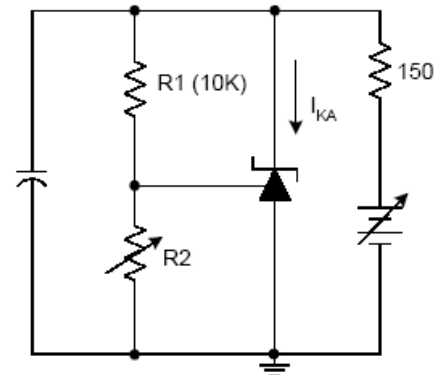
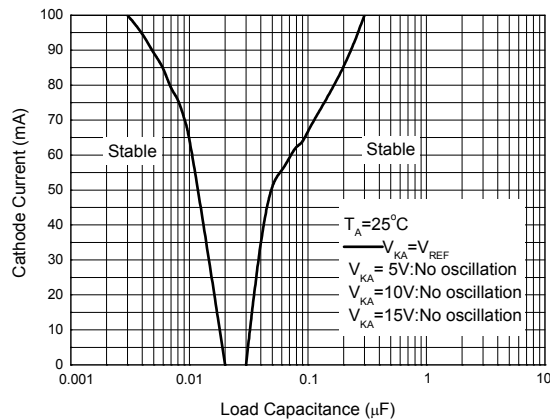

**Performance Characteristics (Cont.)**

**Pulse Response of Input and Output Voltage**

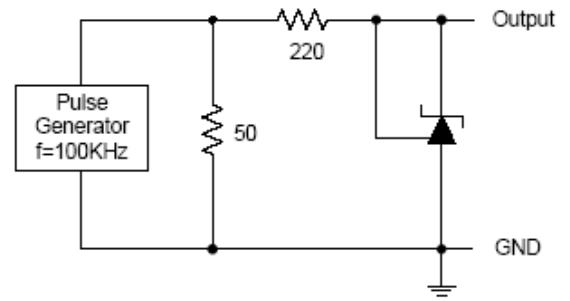
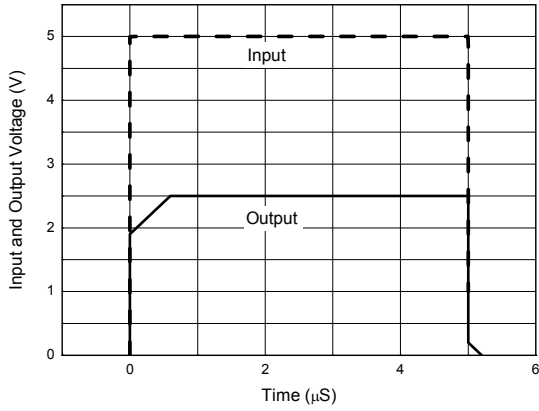

**Ordering Information**

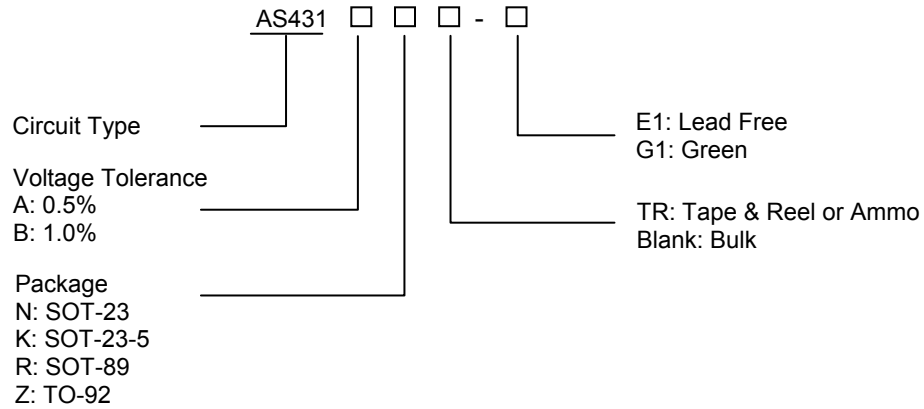

Package	Temperature Range	Voltage Tolerance	Part Number		Marking ID		Packing Type
			Lead Free	Green	Lead Free	Green	
SOT-23	-40 to +125°C	0.5%	AS431ANTR-E1	AS431ANTR-G1	EB5	GB5	Tape & Reel
		1.0%	AS431BNTR-E1	AS431BNTR-G1	EB6	GB6	Tape & Reel
SOT-23-5	-40 to +125°C	0.5%	AS431AKTR-E1	AS431AKTR-G1	E6H	G6H	Tape & Reel
		1.0%	AS431BKTR-E1	AS431BKTR-G1	E6I	G6I	Tape & Reel
TO-92	-40 to +125°C	0.5%	AS431AZ-E1	AS431AZ-G1	AS431AZ-E1	AS431AZ-G1	Bulk
		0.5%	AS431AZTR-E1	AS431AZTR-G1	AS431AZ-E1	AS431AZ-G1	Ammo
		1.0%	AS431BZ-E1	AS431BZ-G1	AS431BZ-E1	AS431BZ-G1	Bulk
		1.0%	AS431BZTR-E1	AS431BZTR-G1	AS431BZ-E1	AS431BZ-G1	Ammo
SOT-89	-40 to +125°C	0.5%	AS431ARTR-E1	AS431ARTR-G1	E43G	G43G	Tape & Reel
		1.0%	AS431BRTR-E1	AS431BRTR-G1	E43H	G43H	Tape & Reel

BCD Semiconductor's Pb-free products, as designated with "E1" suffix in the part number, are RoHS compliant. Products with "G1" suffix are available in green packages.

**Package Outline Dimensions** (All dimensions in mm(inch).)

**TO-92 (Bulk Packing)**

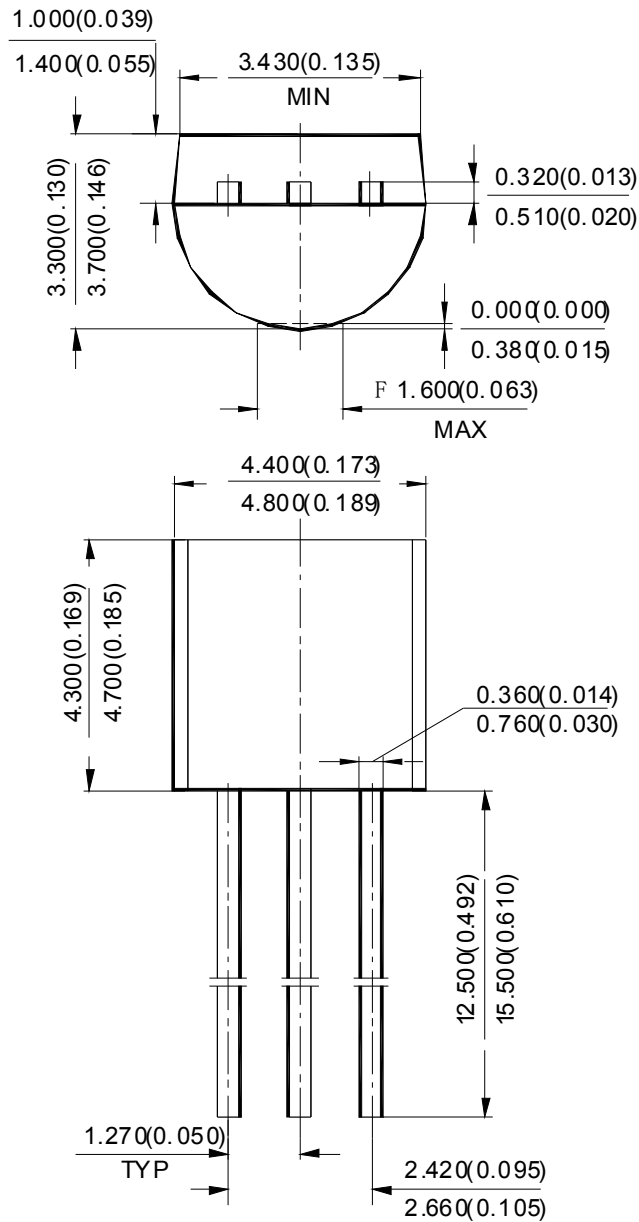

**Package Outline Dimensions** (Cont. All dimensions in mm(inch).)

**TO-92 (Ammo Packing)**

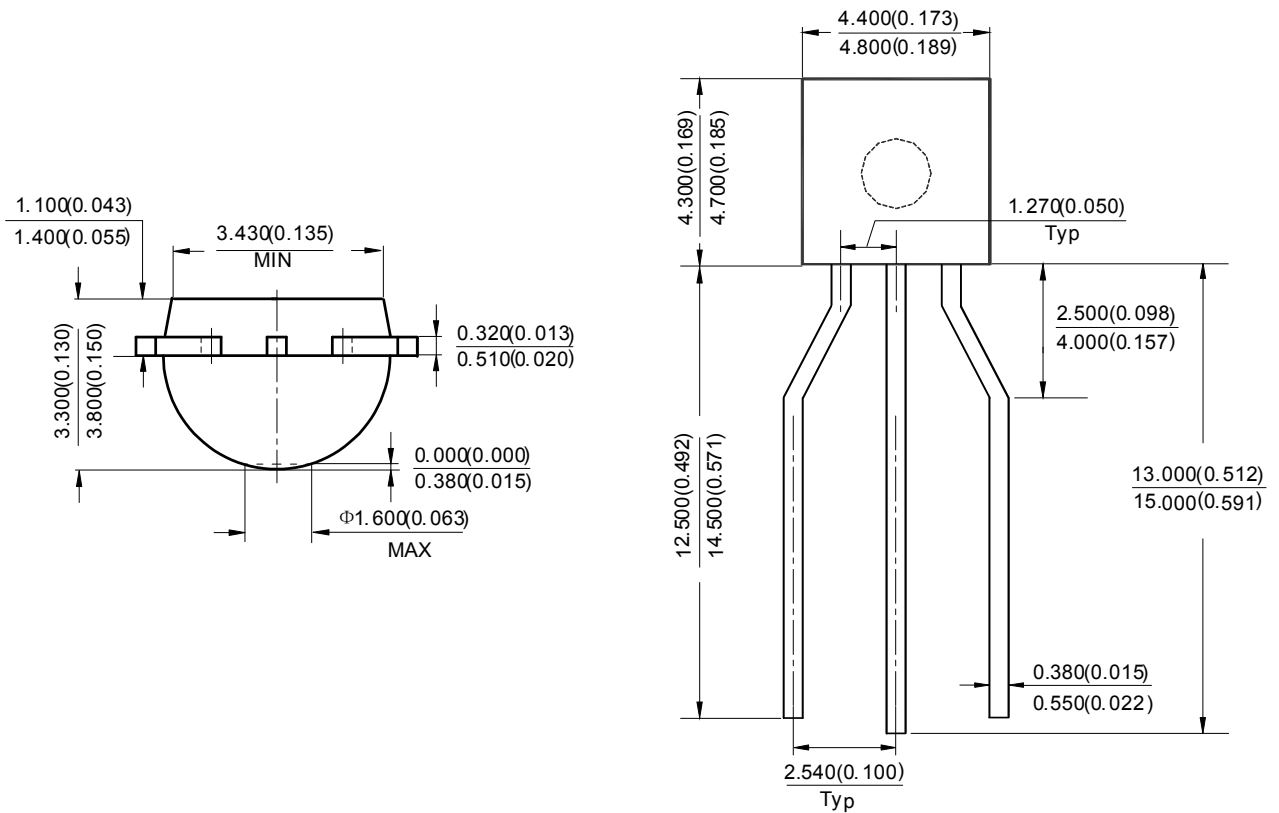

**Package Outline Dimensions** (Cont. All dimensions in mm(inch).)

**SOT-23**

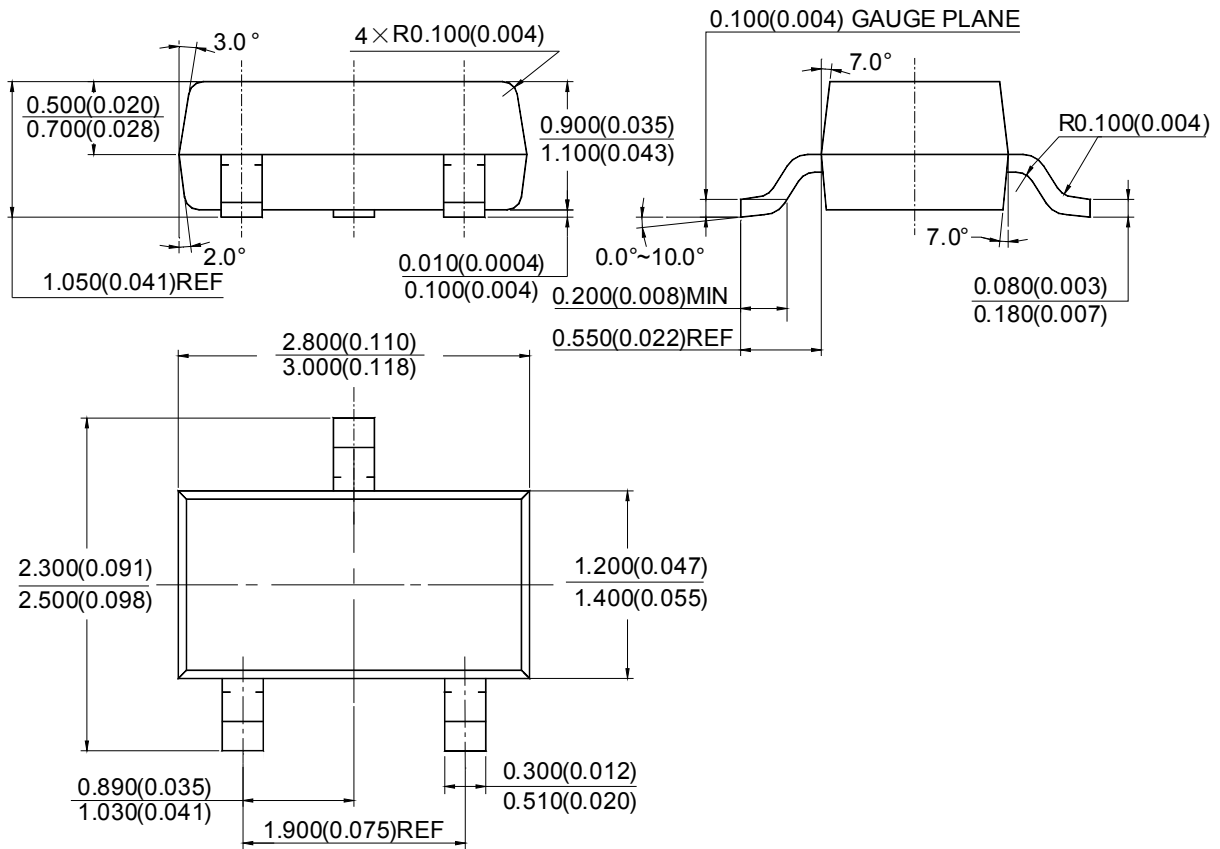

**Package Outline Dimensions** (Cont. All dimensions in mm(inch).)

**SOT-23-5**

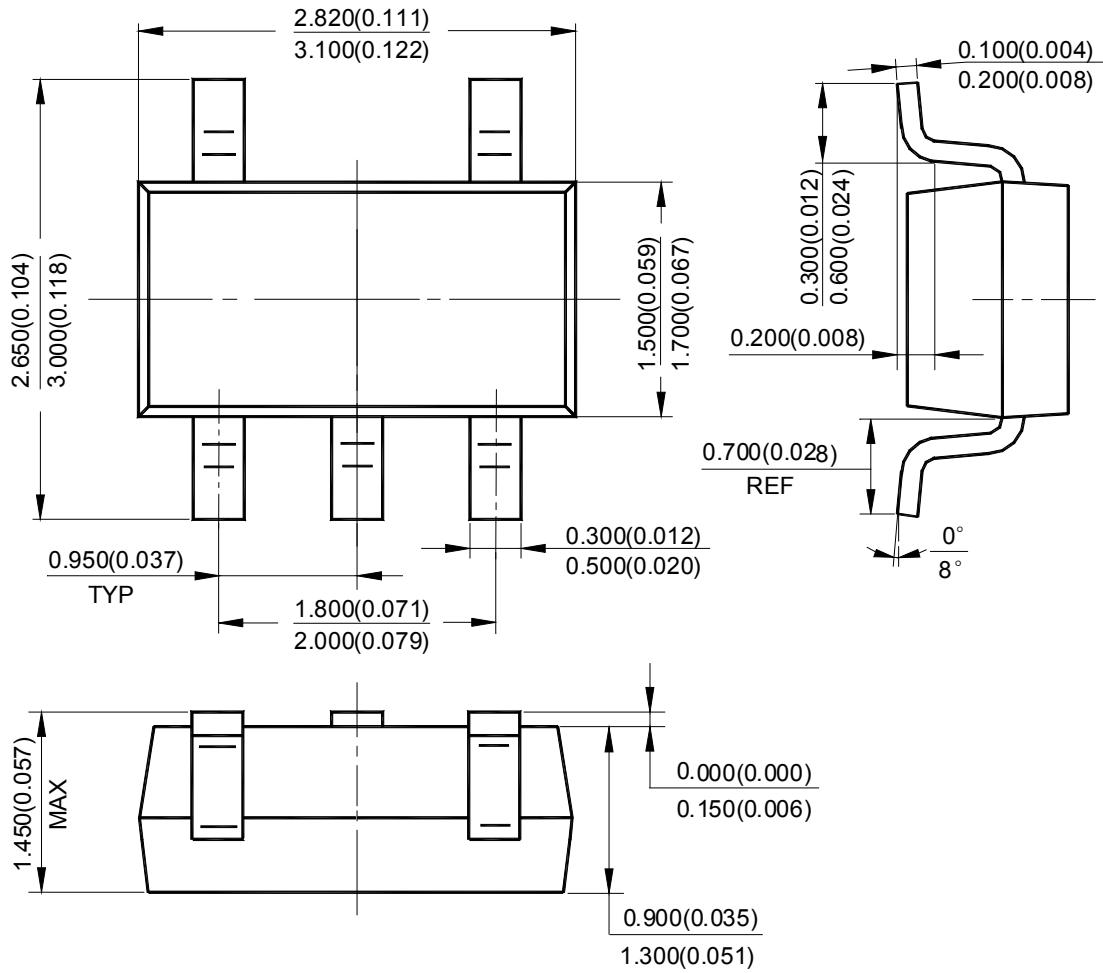

**Package Outline Dimensions** (Cont. All dimensions in mm(inch).)

**SOT-89**

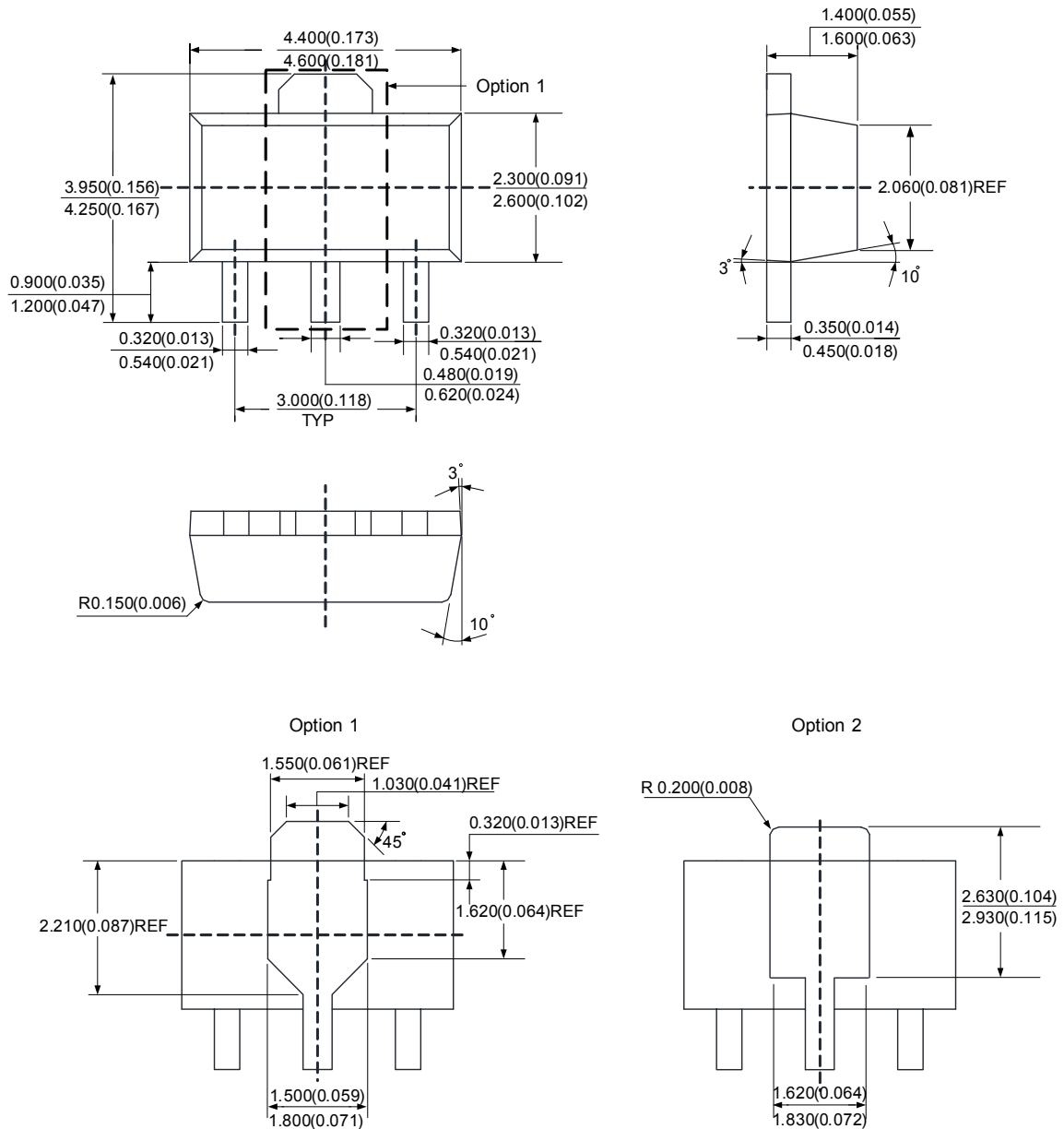

**Suggested Pad Layout**

**SOT-23**

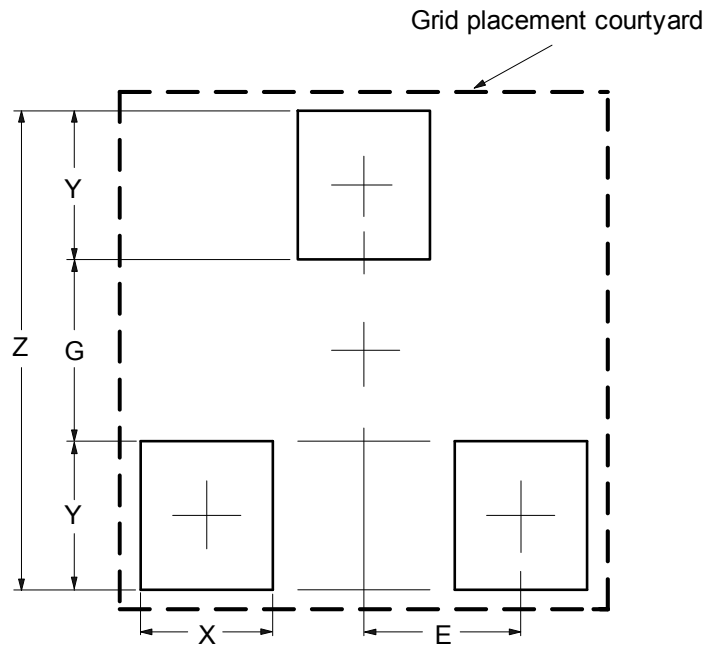

Dimensions	Z (mm)/(inch)	G (mm)/(inch)	X (mm)/(inch)	Y (mm)/(inch)	E (mm)/(inch)
Value	2.900/0.114	1.100/0.043	0.800/0.031	0.900/0.035	0.950/0.037

**Suggested Pad Layout (Cont.)**

**SOT-23-5**

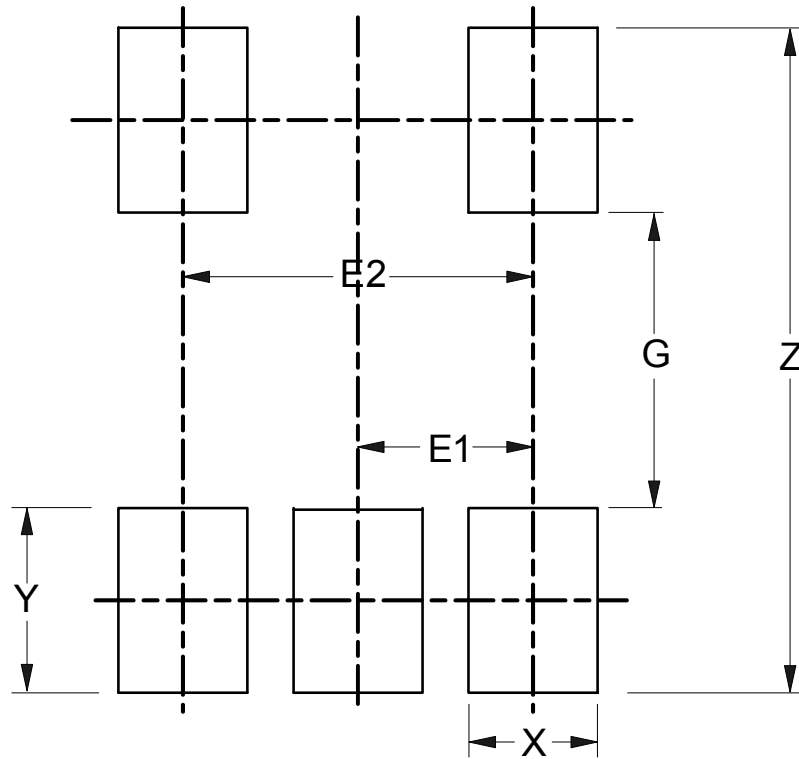

Dimensions	Z (mm)/(inch)	G (mm)/(inch)	X (mm)/(inch)	Y (mm)/(inch)	E1 (mm)/(inch)	E2 (mm)/(inch)
Value	3.600/0.142	1.600/0.063	0.700/0.028	1.000/0.039	0.950/0.037	1.900/0.075

**Suggested Pad Layout** (Cont.)

**SOT-89**

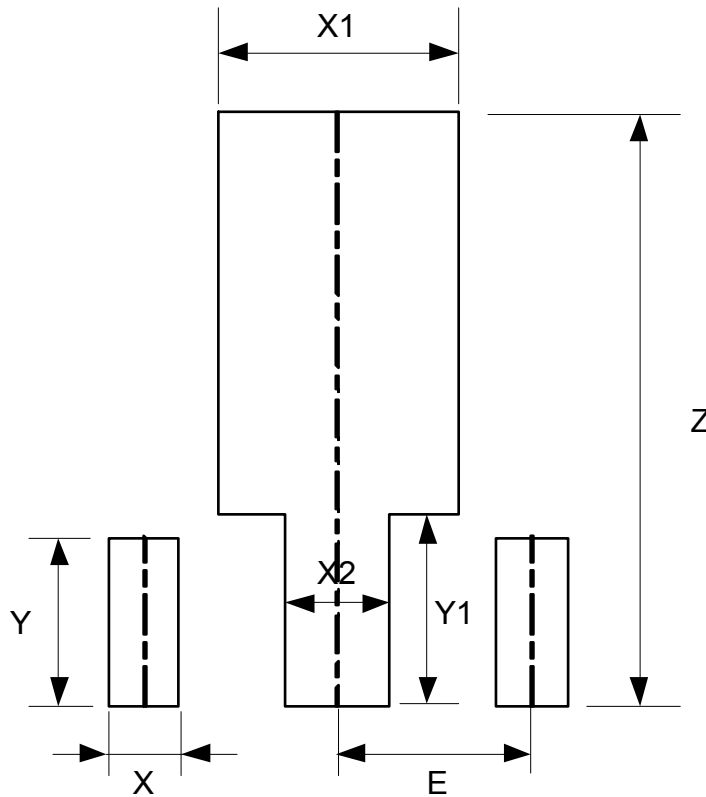

Dimensions	Z (mm)/(inch)	X (mm)/(inch)	X1 (mm)/(inch)	X2 (mm)/(inch)	Y (mm)/(inch)	Y1 (mm)/(inch)	E (mm)/(inch)
Value	4.600/0.181	0.550/0.022	1.850/0.073	0.800/0.031	1.300/0.051	1.475/0.058	1.500/0.059

**IMPORTANT NOTICE**

DIODES INCORPORATED MAKES NO WARRANTY OF ANY KIND, EXPRESS OR IMPLIED, WITH REGARDS TO THIS DOCUMENT, INCLUDING, BUT NOT LIMITED TO, THE IMPLIED WARRANTIES OF MERCHANTABILITY AND FITNESS FOR A PARTICULAR PURPOSE (AND THEIR EQUIVALENTS UNDER THE LAWS OF ANY JURISDICTION).

Diodes Incorporated and its subsidiaries reserve the right to make modifications, enhancements, improvements, corrections or other changes without further notice to this document and any product described herein. Diodes Incorporated does not assume any liability arising out of the application or use of this document or any product described herein; neither does Diodes Incorporated convey any license under its patent or trademark rights, nor the rights of others. Any Customer or user of this document or products described herein in such applications shall assume all risks of such use and will agree to hold Diodes Incorporated and all the companies whose products are represented on Diodes Incorporated website, harmless against all damages.

Diodes Incorporated does not warrant or accept any liability whatsoever in respect of any products purchased through unauthorized sales channel. Should Customers purchase or use Diodes Incorporated products for any unintended or unauthorized application, Customers shall indemnify and hold Diodes Incorporated and its representatives harmless against all claims, damages, expenses, and attorney fees arising out of, directly or indirectly, any claim of personal injury or death associated with such unintended or unauthorized application.

Products described herein may be covered by one or more United States, international or foreign patents pending. Product names and markings noted herein may also be covered by one or more United States, international or foreign trademarks.

This document is written in English but may be translated into multiple languages for reference. Only the English version of this document is the final and determinative format released by Diodes Incorporated.

**LIFE SUPPORT**

Diodes Incorporated products are specifically not authorized for use as critical components in life support devices or systems without the express written approval of the Chief Executive Officer of Diodes Incorporated. As used herein:

A. Life support devices or systems are devices or systems which:

1. are intended to implant into the body, or
2. support or sustain life and whose failure to perform when properly used in accordance with instructions for use provided in the labeling can be reasonably expected to result in significant injury to the user.

B. A critical component is any component in a life support device or system whose failure to perform can be reasonably expected to cause the failure of the life support device or to affect its safety or effectiveness.

Customers represent that they have all necessary expertise in the safety and regulatory ramifications of their life support devices or systems, and acknowledge and agree that they are solely responsible for all legal, regulatory and safety-related requirements concerning their products and any use of Diodes Incorporated products in such safety-critical, life support devices or systems, notwithstanding any devices- or systems-related information or support that may be provided by Diodes Incorporated. Further, Customers must fully indemnify Diodes Incorporated and its representatives against any damages arising out of the use of Diodes Incorporated products in such safety-critical, life support devices or systems.

Copyright © 2013, Diodes Incorporated

[www.diodes.com](http://www.diodes.com)



LittleDiode supplies new, hard to find or obsolete electronic components and semiconductors all over the world.

With over two million different components listed you are sure to find the part you need.

Feel free to visit us today at our online store:

[LittleDiode.com](http://LittleDiode.com)

Looking forward to providing you with the best possible service.