

### Features

- Input voltage: 4V to 23V
- Output voltage: 0.8V to  $V_{CC}$
- Output current: 1.8A up to peak 2A
- Duty ratio: 0% to 99% PWM control
- Oscillation frequency: 300KHz typ.
- Soft-start like, Current limit and Enable function
- Thermal Shutdown function
- Built-in internal SW P-channel MOS
- SOP-8L: Available in "Green" Molding Compound (No Br, Sb)
- Lead Free Finish/ RoHS Compliant (Note 1)

### General Description

AP1533 consists of step-down switching regulator with PWM control. These devices include a reference voltage source, oscillation circuit, error amplifier, internal PMOS.

AP1533 provides low-ripple power, high efficiency, and excellent transient characteristics. The PWM control circuit is able to vary the duty ratio linearly from 0 up to 99%. This converter also contains an error amplifier circuit as well as a soft-start circuit that prevents overshoot at startup. An enable function, an over current protect function and a short circuit protect function are built inside, and when OCP or SCP happens, the operation frequency will be reduced from 300KHz to 50KHz. Also, an internal compensation block is built in to minimum external component count.

With the addition of an internal P-channel Power MOS, a coil, capacitors, and a diode connected externally, these ICs can function as step-down switching regulators. They serve as ideal power supply units for portable devices when coupled with the SOP-8L mini-package, providing such outstanding features as low current consumption. Since this converter can accommodate an input voltage up to 23V, it is also suitable for the operation via an AC adapter.

### Applications

- PC Motherboard
- LCD Monitor
- Graphic Card
- DVD-Video Player
- Telecom Equipment
- ADSL Modem
- Printer and other Peripheral Equipment
- Microprocessor core supply

### Typical Application Circuit

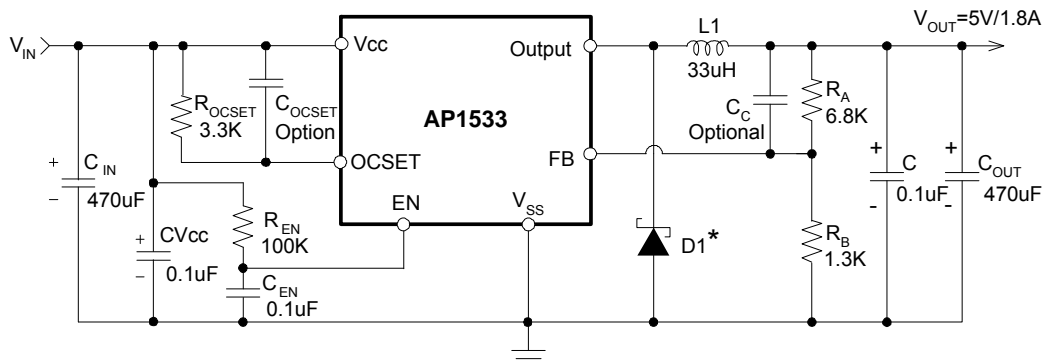

$$V_{OUT} = V_{FB} \times (1 + R_A/R_B)$$

$$R_B = 0.7K \sim 5K \text{ ohm}$$

\* Suggested DIODES Power Schottky P/N: B340 series or PDS340.

### Ordering Information

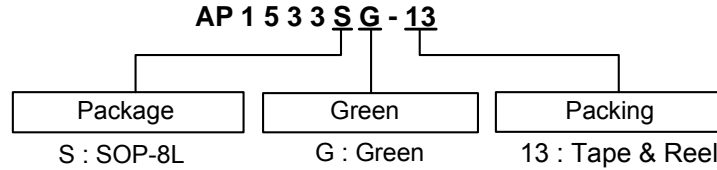

Device	Package Code	Packaging (Note 2)	13" Tape and Reel	
			Quantity	Part Number Suffix
AP1533SG-13	S	SOP-8L	2500/Tape & Reel	-13

- Notes:
1. EU Directive 2002/95/EC (RoHS). All applicable RoHS exemptions applied. Please visit our website at [http://www.diodes.com/products/lead\\_free.html](http://www.diodes.com/products/lead_free.html).
  2. Pad layout as shown on Diodes Inc. suggested pad layout document AP02001, which can be found on our website at <http://www.diodes.com/datasheets/ap02001.pdf>.

### Pin Assignments

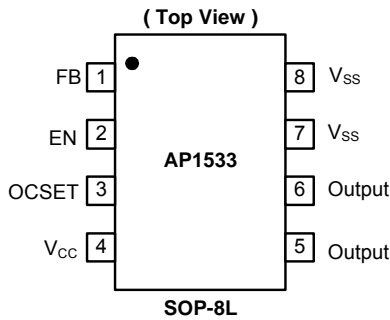

### Pin Descriptions

Pin Name	Pin No.	Description
FB	1	Feedback pin
EN	2	Power-off pin H: Normal operation (Step-down operation) L: Step-down operation stopped (All circuits deactivated)
OCSET	3	Add an external resistor to set max output current
V <sub>CC</sub>	4	IC power supply pin
Output	5, 6	Switch Pin. Connect external inductor/diode here. Minimize trace area at this pin to reduce EMI
V <sub>SS</sub>	7, 8	GND Pin

### Block Diagram

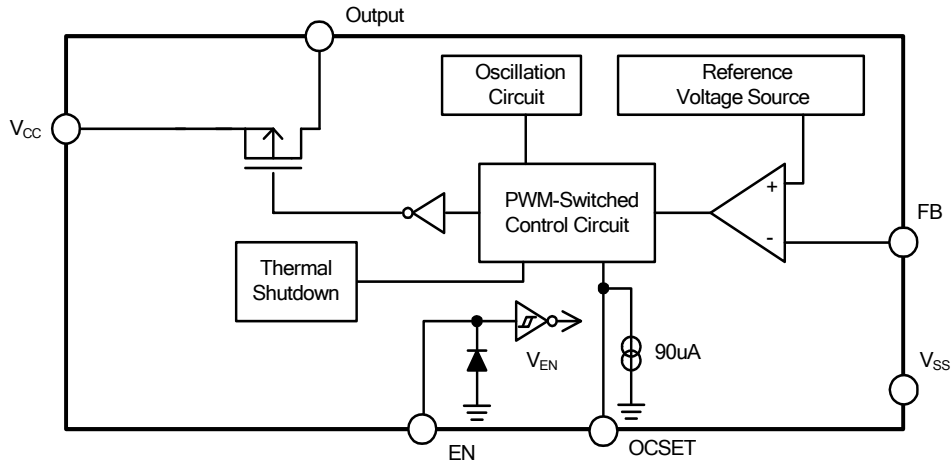

### Absolute Maximum Ratings

Symbol	Parameter	Rating	Unit
ESD HBM	Human Body Model ESD Protection	8	KV
ESD MM	Machine Model ESD Protection	500	V
$V_{CC}$	$V_{CC}$ Pin Voltage	$V_{SS} - 0.3$ to $V_{SS} + 24$	V
$V_{FB}$	Feedback Pin Voltage	$V_{SS} - 0.3$ to $V_{CC}$	V
$V_{EN}$	EN Pin Voltage	$V_{SS} - 0.3$ to $V_{IN} + 0.3$	V
$V_{OUT}$	Switch Pin Voltage	$V_{SS} - 0.3$ to $V_{IN} + 0.3$	V
$P_D$	Power Dissipation	Internally limited	mW
$T_J$	Operating Junction Temperature Range	-20 to +125	°C
$T_{ST}$	Storage Temperature Range	-65 to +150	°C

Caution: The absolute maximum ratings are rated values exceeding which the product could suffer physical damage. These values must therefore not be exceeded under any conditions.

### Recommended Operating Conditions

Symbol	Parameter	Min	Max	Unit
$V_{IN}$	Input Voltage	4	23	V
$I_{OUT}$	Output Current	0	1.8	A
$T_A$	Operating Ambient Temperature	-25	85	°C

**Electrical Characteristics**

 ( $V_{IN} = 12V$ ,  $T_A = 25^\circ C$ , unless otherwise specified)

Symbol	Parameter	Conditions	Min	Typ.	Max	Unit
$V_{FB}$	Feedback Voltage	$I_{OUT} = 0.1A$	0.784	0.8	0.816	V
$I_{FB}$	Feedback Bias Current	$I_{OUT} = 0.1A$	-	0.1	0.5	$\mu A$
$I_{SHDN}$	Current Consumption During Power Off	$V_{EN} = 0V$	-	10	-	$\mu A$
$\frac{\Delta V_{OUT}}{V_{IN}}$	Line Regulation	$V_{IN} = 5V \sim 23V$	-	1	2	%
$\frac{\Delta V_{OUT}}{V_{OUT}}$	Load Regulation	$I_{OUT} = 0.1$ to 1.8A	-	0.2	0.5	%
$f_{OSC}$	Oscillation Frequency	Measure waveform at SW pin	240	300	400	KHz
$f_{OSC1}$	Frequency of Current Limit or Short Circuit Protection	Measure waveform at SW pin	-	50	-	KHz
$V_{IH}$	EN Pin Input Voltage	Evaluate oscillation at SW pin	2.0	-	-	V
$V_{IL}$		Evaluate oscillation stop at SW pin	-	-	0.8	
$I_{SH}$	EN Pin Input Leakage Current	EN Pin High	-	20	-	$\mu A$
$I_{SL}$		EN Pin Low	-	-10	-	$\mu A$
$I_{OCSET}$	OCSET Pin Bias Current	--	75	90	105	$\mu A$
$R_{DS(ON)}$	Internal MOSFET $R_{DS(ON)}$	$V_{IN}=5V, V_{FB}=0V$	-	110	150	m $\Omega$
		$V_{IN}=12V, V_{FB}=0V$	-	80	110	
EFFI	Efficiency	$V_{IN}=12V, V_{OUT} = 5V$ $I_{OUT}=1.8A$	-	91	-	%
$T_{SHDN}$	Thermal shutdown threshold		-	150	-	$^\circ C$
$T_{HYS}$	Thermal shutdown hysteresis		-	55	-	$^\circ C$
$\theta_{JA}$	Thermal Resistance Junction-to-Ambient	SOP-8L (Note 3)	-	134	-	$^\circ C/W$
$\theta_{JC}$	Thermal Resistance Junction-to-Case	SOP-8L (Note 3)	-	22	-	$^\circ C/W$

Notes: 3. Test condition: Device mounted on FR-4 PCB, 2"x2", 2oz copper, minimum recommended pad layout, single side. For better thermal performance, larger copper pad for heatsink is needed.

**Typical Performance Characteristics (Continued)**

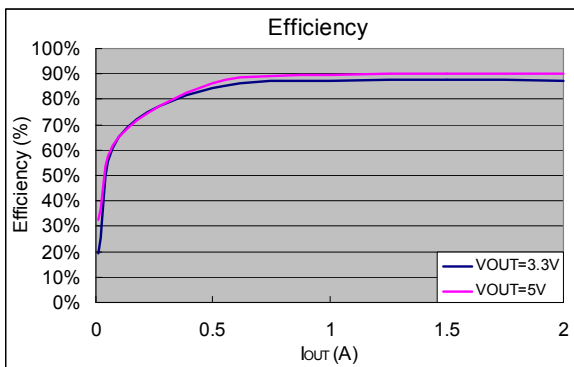
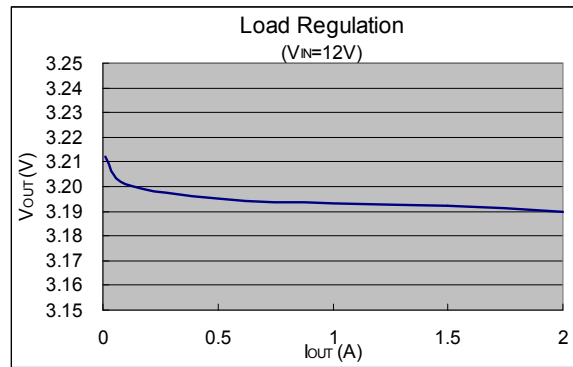
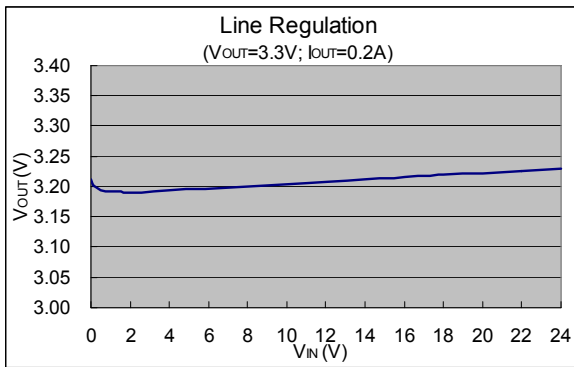
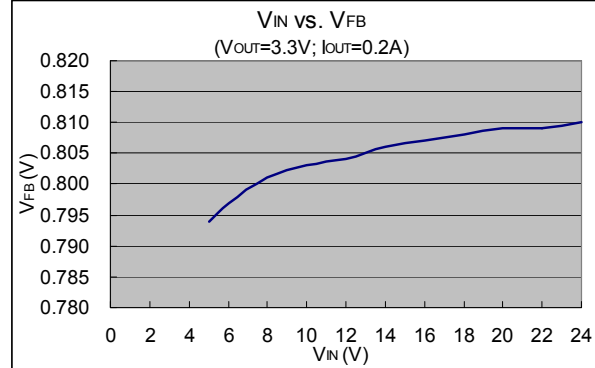
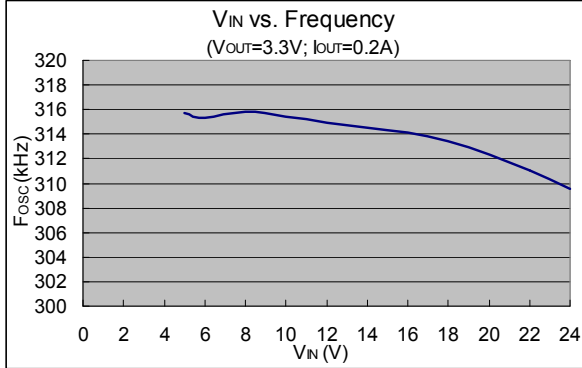

**Typical Performance Characteristics (Continued)**

**V<sub>OUT</sub> Ripple**  
( V<sub>IN</sub> = 12V; V<sub>OUT</sub> = 3.3V; I<sub>OUT</sub> = 0.1A )

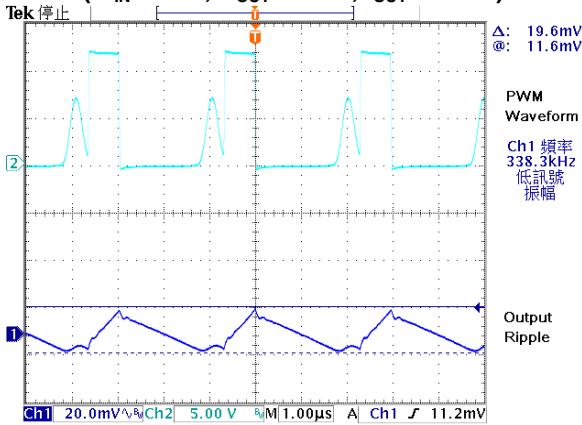

**V<sub>OUT</sub> Ripple**  
( V<sub>IN</sub> = 12V; V<sub>OUT</sub> = 3.3V; I<sub>OUT</sub> = 1.8A )

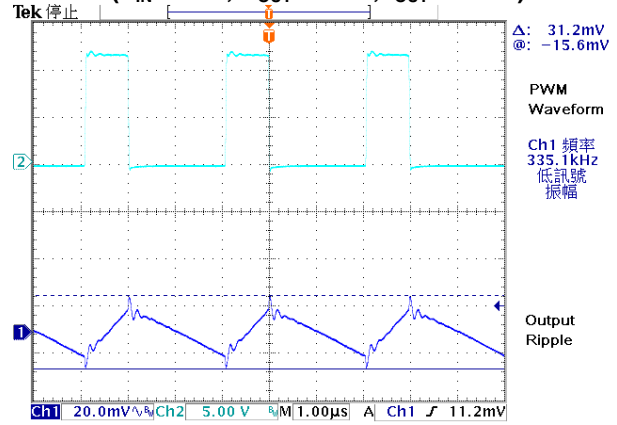

**Test Circuit**

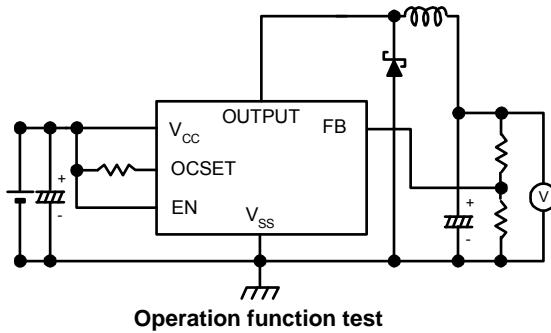
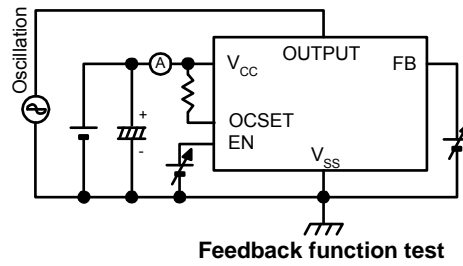
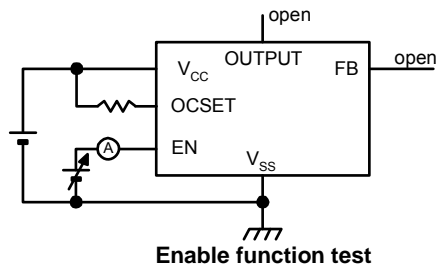

### Functional Description

#### PWM Control

The AP1533 is a DC/DC converter that employs pulse width modulation (PWM) scheme. Its pulse width varies in the range of 0% to 99%, based on the output current loading. The output ripple voltage caused by the PWM high frequency switching can easily be reduced through an output filter. Therefore, this converter provides a low ripple output supply over a broad range of input voltage & output current loading

#### Under Voltage Lockout

The under voltage lockout circuit of the AP1533 assures that the high-side MOSFET driver remains in the off state whenever the supply voltage drops below 3.3V. Normal operation resumes once  $V_{CC}$  rises above 3.5V.

#### Current Limit Protection

The current limit threshold is set by external resistor  $R_{OCSET}$  connected from  $V_{CC}$  supply to OCSET pin. The internal sink current  $I_{OCSET}$  (90 $\mu$ A typical) across this resistor sets the voltage at OCSET pin. When the PWM voltage is less than the voltage at OCSET, an over-current condition is triggered.

The current limit threshold is given by the following equation:

$$I_{PEAK} \times R_{DS(ON)} = I_{OCSET} \times R_{OCSET}$$

$$I_{PEAK} > I_{OUT(MAX)} + \frac{(\Delta I)}{2}$$

where,

$$\Delta I = \frac{V_{IN} - V_{OUT}}{f_s \times L} \times \frac{V_{OUT}}{V_{IN}}$$

$I_{PEAK}$  is the output peak current;  $R_{DS(ON)}$  is the MOSFET ON resistance;  $f_s$  is the PWM frequency (300KHz typical). Also, the inductor value will affect the ripple current  $\Delta I$ .

The above equation is recommended for input voltage range of 5V to 18V. For input voltage lower than 5V or ambient temperature over 100°C, higher  $R_{OCSET}$  is recommended.

The recommended minimum  $R_{OCSET}$  value is summarized below:

$V_{IN}$ (V)	$V_{OUT}$ (V)	$R_{OCSET}$ ( $\Omega$ )
4	0.8	3.9K
5	3.3	3.3K
12	5	3.3K
18	12	3.3K
23	12	4.7K

The maximum  $R_{OCSET}$  value should not exceed AP1533 maximum current output.

#### Inductor Selection

For most designs, the operation range with inductors is from 22 $\mu$ H to 33 $\mu$ H. The inductor value can be derived from the following equation:

$$L = \frac{V_{IN} - V_{OUT}}{f_s \times \Delta I} \times \frac{V_{OUT}}{V_{IN}}$$

Where  $\Delta I_L$  is inductor Ripple Current. Large value inductors lower ripple current and small value inductors result in high ripple current. Choose inductor ripple current approximately 15% of the maximum load current 1.8A,  $\Delta I_L = 0.27A$ . The DC current rating of the inductor should be at least equal to the maximum load current plus half the ripple current to prevent core saturation (1.8A+0.135A).

#### Input Capacitor Selection

This capacitor should be located close to the IC using short leads and the voltage rating should be approximately 1.5 times the maximum input voltage. The RMS current rating requirement for the input capacitor of a buck regulator is approximately 1/2 the DC load current. A low ESR input capacitor sized for maximum RMS current must be used. A 470 $\mu$ F low ESR capacitor for most applications is sufficient.

#### Output Capacitor Selection

The output capacitor is required to filter the output voltage and provides regulator loop stability. The important capacitor parameters are the 100KHz Equivalent Series Resistance (ESR), the RMS ripples current rating, voltage rating and capacitance value. For the output capacitor, the ESR value is the most important parameter. The output ripple can be calculated from the following formula.

$$V_{RIPPLE} = \Delta I_L \times ESR$$

The bulk capacitor's ESR will determine the output ripple voltage and the initial voltage drop after a high slew-rate transient.

An aluminum electrolytic capacitor's ESR value is related to the capacitance and its voltage rating. In most case, higher voltage electrolytic capacitors have lower ESR values. Most of the time, capacitors with much higher voltage ratings may be needed to provide the low ESR values required for low output ripple voltage.

#### PCB Layout Guide

If you need low  $T_C$  &  $T_J$  or large  $P_D$  (Power Dissipation), The dual SW pins(5& 6) and Vss pins(7& 8) on the SOP-8L package are internally connected to die pad, The evaluation board should be allowed for maximum copper area at output (SW) pins.

1. Connect FB circuits as closely as possible and keep away from inductor flux for pure  $V_{FB}$ .
2. Connect input capacitor to Vcc and Vss pin as closely as possible to get good power filter effect.
3. Connect  $R_{OCSET}$  to Vcc and OCSET pin as closely as possible.
4. Connect ground side of the input capacitor & Schottky & output capacitor as closely as possible and use ground plane for best performance.

**Marking Information**

(1) SOP-8L

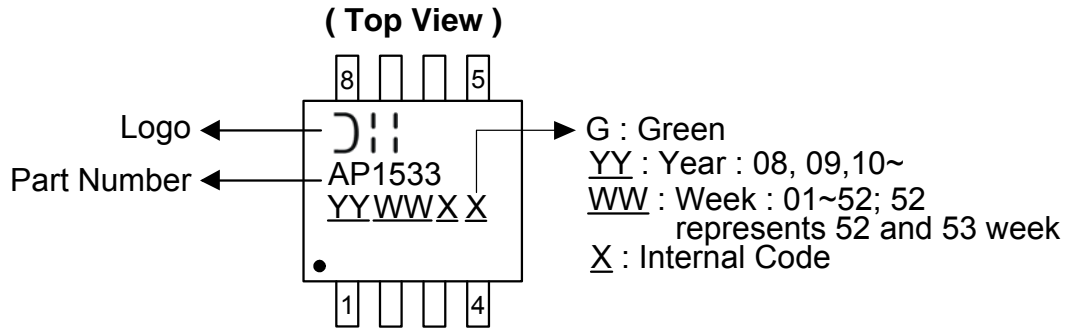

**Package Information ( All Dimensions in mm )**

(1) Package Type: SOP-8L

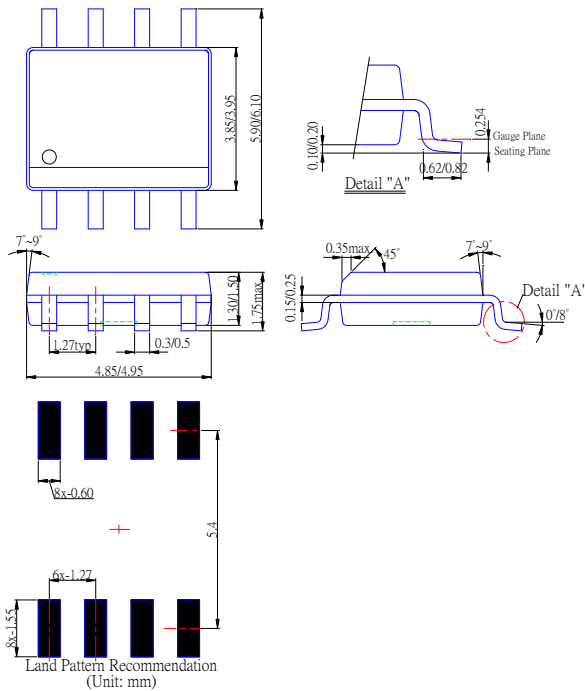

**IMPORTANT NOTICE**

DIODES INCORPORATED MAKES NO WARRANTY OF ANY KIND, EXPRESS OR IMPLIED, WITH REGARDS TO THIS DOCUMENT, INCLUDING, BUT NOT LIMITED TO, THE IMPLIED WARRANTIES OF MERCHANTABILITY AND FITNESS FOR A PARTICULAR PURPOSE (AND THEIR EQUIVALENTS UNDER THE LAWS OF ANY JURISDICTION).

Diodes Incorporated and its subsidiaries reserve the right to make modifications, enhancements, improvements, corrections or other changes without further notice to this document and any product described herein. Diodes Incorporated does not assume any liability arising out of the application or use of this document or any product described herein; neither does Diodes Incorporated convey any license under its patent or trademark rights, nor the rights of others. Any Customer or user of this document or products described herein in such applications shall assume all risks of such use and will agree to hold Diodes Incorporated and all the companies whose products are represented on Diodes Incorporated website, harmless against all damages.

Diodes Incorporated does not warrant or accept any liability whatsoever in respect of any products purchased through unauthorized sales channel.

Should Customers purchase or use Diodes Incorporated products for any unintended or unauthorized application, Customers shall indemnify and hold Diodes Incorporated and its representatives harmless against all claims, damages, expenses, and attorney fees arising out of, directly or indirectly, any claim of personal injury or death associated with such unintended or unauthorized application.

Products described herein may be covered by one or more United States, international or foreign patents pending. Product names and markings noted herein may also be covered by one or more United States, international or foreign trademarks.

**LIFE SUPPORT**

Diodes Incorporated products are specifically not authorized for use as critical components in life support devices or systems without the express written approval of the Chief Executive Officer of Diodes Incorporated. As used herein:

A. Life support devices or systems are devices or systems which:

1. are intended to implant into the body, or
2. support or sustain life and whose failure to perform when properly used in accordance with instructions for use provided in the labeling can be reasonably expected to result in significant injury to the user.

B. A critical component is any component in a life support device or system whose failure to perform can be reasonably expected to cause the failure of the life support device or to affect its safety or effectiveness.

Customers represent that they have all necessary expertise in the safety and regulatory ramifications of their life support devices or systems, and acknowledge and agree that they are solely responsible for all legal, regulatory and safety-related requirements concerning their products and any use of Diodes Incorporated products in such safety-critical, life support devices or systems, notwithstanding any devices- or systems-related information or support that may be provided by Diodes Incorporated. Further, Customers must fully indemnify Diodes Incorporated and its representatives against any damages arising out of the use of Diodes Incorporated products in such safety-critical, life support devices or systems.

Copyright © 2009, Diodes Incorporated

[www.diodes.com](http://www.diodes.com)



LittleDiode supplies new, hard to find or obsolete electronic components and semiconductors all over the world.

With over two million different components listed you are sure to find the part you need.

Feel free to visit us today at our online store:

[LittleDiode.com](http://LittleDiode.com)

Looking forward to providing you with the best possible service.