

## Features

- Temperature ranges
  - Commercial: 0 °C to +70 °C
  - Industrial: -40 °C to +85 °C
  - Automotive-A: -40 °C to +85 °C
  - Automotive-E: -40 °C to +125 °C
- High speed: 55 ns
- Voltage range: 4.5 V to 5.5 V operation
- Low active power
  - 275 mW (max)
- Low standby power (LL version)
  - 82.5 μW (max)
- Easy memory expansion with  $\overline{CE}$  and  $\overline{OE}$  Features
- TTL-compatible inputs and outputs
- Automatic power-down when deselected
- CMOS for optimum speed and power
- Available in Pb-free and non Pb-free 28-pin (600-mil) PDIP, 28-pin (300-mil) narrow SOIC, 28-pin TSOP I, and 28-pin reverse TSOP I packages

## Functional Description

The CY62256N is a high performance CMOS static RAM organized as 32K words by 8 bits. Easy memory expansion is provided by an active LOW chip enable ( $\overline{CE}$ ) and active LOW output enable ( $\overline{OE}$ ) and tristate drivers. This device has an automatic power-down feature, reducing the power consumption by 99.9 percent when deselected.

An active LOW write enable signal ( $\overline{WE}$ ) controls the writing/reading operation of the memory. When  $\overline{CE}$  and  $\overline{WE}$  inputs are both LOW, data on the eight data input/output pins ( $I/O_0$  through  $I/O_7$ ) is written into the memory location addressed by the address present on the address pins ( $A_0$  through  $A_{14}$ ). Reading the device is accomplished by selecting the device and enabling the outputs,  $\overline{CE}$  and  $\overline{OE}$  active LOW, while  $\overline{WE}$  remains inactive or HIGH. Under these conditions, the contents of the location addressed by the information on address pins are present on the eight data input/output pins.

The input/output pins remain in a high impedance state unless the chip is selected, outputs are enabled, and write enable ( $\overline{WE}$ ) is HIGH.

## Logic Block Diagram

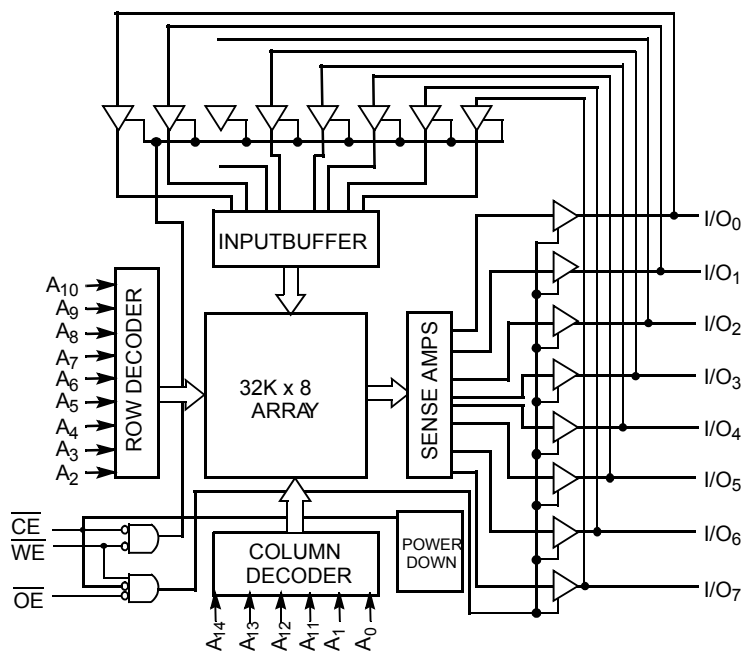

## Contents

<b>Product Portfolio</b> .....	<b>3</b>	<b>Truth Table</b> .....	<b>11</b>
<b>Pin Configurations</b> .....	<b>3</b>	<b>Ordering Information</b> .....	<b>12</b>
<b>Pin Definitions</b> .....	<b>3</b>	Ordering Code Definitions .....	12
<b>Maximum Ratings</b> .....	<b>4</b>	<b>Package Diagrams</b> .....	<b>13</b>
<b>Operating Range</b> .....	<b>4</b>	<b>Acronyms</b> .....	<b>15</b>
<b>Electrical Characteristics</b> .....	<b>4</b>	<b>Document Conventions</b> .....	<b>15</b>
<b>Capacitance</b> .....	<b>5</b>	Units of Measure .....	15
<b>Thermal Resistance</b> .....	<b>5</b>	<b>Document History Page</b> .....	<b>16</b>
<b>AC Test Loads and Waveforms</b> .....	<b>5</b>	<b>Sales, Solutions, and Legal Information</b> .....	<b>17</b>
<b>Data Retention Characteristics</b> .....	<b>6</b>	Worldwide Sales and Design Support .....	17
<b>Data Retention Waveform</b> .....	<b>6</b>	Products .....	17
<b>Switching Characteristics</b> .....	<b>7</b>	PSoC® Solutions .....	17
<b>Switching Waveforms</b> .....	<b>8</b>	Cypress Developer Community .....	17
<b>Typical DC and AC Characteristics</b> .....	<b>10</b>	Technical Support .....	17

**Product Portfolio**

Product		V <sub>CC</sub> Range (V)			Speed (ns)	Power Dissipation			
		Min	Typ <sup>[1]</sup>	Max		Operating, I <sub>CC</sub> (mA)		Standby, I <sub>SB2</sub> (μA)	
					Typ <sup>[1]</sup>	Max	Typ <sup>[1]</sup>	Max	
CY62256NLL	Commercial	4.5	5.0	5.5	70	25	50	0.1	5
CY62256NLL	Industrial				55/70	25	50	0.1	10
CY62256NLL	Automotive-A				55/70	25	50	0.1	10
CY62256NLL	Automotive-E				55	25	50	0.1	15

**Pin Configurations**

Figure 1. 28-pin DIP and Narrow SOIC pinout

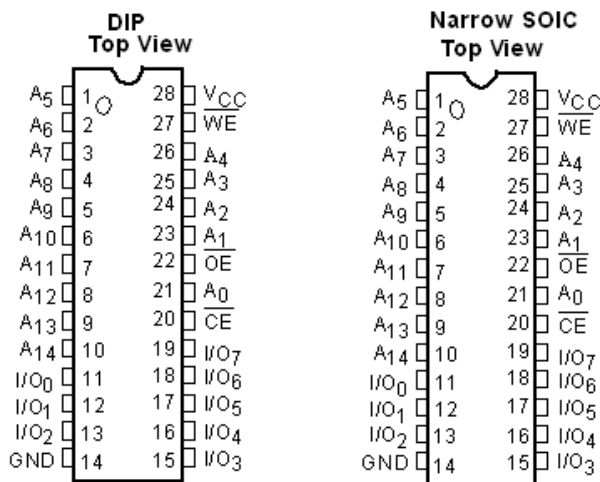
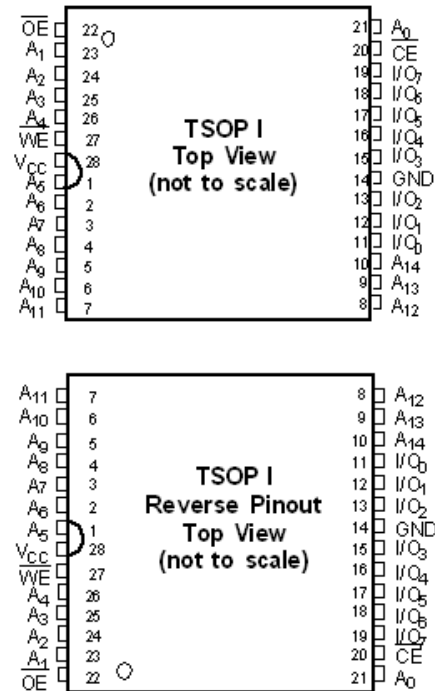

Figure 2. 28-pin TSOP I and Reverse TSOP I pinout



**Pin Definitions**

Pin Number	Type	Description
1–10, 21, 23–26	Input	<b>A<sub>0</sub>–A<sub>14</sub></b> . Address Inputs
11–13, 15–19,	Input/Output	<b>I/O<sub>0</sub>–I/O<sub>7</sub></b> . Data lines. Used as input or output lines depending on operation
27	Input/Control	<b>WE</b> . When selected LOW, a WRITE is conducted. When selected HIGH, a READ is conducted
20	Input/Control	<b>CE</b> . When LOW, selects the chip. When HIGH, deselects the chip
22	Input/Control	<b>OE</b> . Output Enable. Controls the direction of the I/O pins. When LOW, the I/O pins behave as outputs. When deasserted HIGH, I/O pins are tristated, and act as input data pins
14	Ground	<b>GND</b> . Ground for the device
28	Power Supply	<b>V<sub>CC</sub></b> . Power supply for the device

**Note**

1. Typical specifications are the mean values measured over a large sample size across normal production process variations and are taken at nominal conditions (T<sub>A</sub> = 25 °C, V<sub>CC</sub>). Parameters are guaranteed by design and characterization, and not 100% tested.

### Maximum Ratings

Exceeding maximum ratings may impair the useful life of the device. These user guidelines are not tested.

- Storage temperature ..... -65 °C to +150 °C
- Ambient temperature with power applied ..... -55 °C to +125 °C
- Supply voltage to ground potential (pin 28 to pin 14) ..... -0.5 V to +7.0 V
- DC voltage applied to outputs in high Z State <sup>[2]</sup> ..... -0.5 V to V<sub>CC</sub> + 0.5 V
- DC input voltage <sup>[2]</sup> ..... -0.5 V to V<sub>CC</sub> + 0.5 V

- Output current into outputs (LOW) ..... 20 mA
- Static discharge voltage (per MIL-STD-883, method 3015) ..... > 2001 V
- Latch-up current ..... > 200 mA

### Operating Range

Range	Ambient Temperature (T <sub>A</sub> ) <sup>[3]</sup>	V <sub>CC</sub>
Commercial	0 °C to +70 °C	5 V ± 10%
Industrial	-40 °C to +85 °C	5 V ± 10%
Automotive-A	-40 °C to +85 °C	5 V ± 10%
Automotive-E	-40 °C to +125 °C	5 V ± 10%

### Electrical Characteristics

Over the Operating Range

Parameter	Description	Test Conditions	-55			-70			Unit	
			Min	Typ <sup>[4]</sup>	Max	Min	Typ <sup>[4]</sup>	Max		
V <sub>OH</sub>	Output HIGH voltage	V <sub>CC</sub> = Min, I <sub>OH</sub> = -1.0 mA	2.4	-	-	2.4	-	-	V	
V <sub>OL</sub>	Output LOW voltage	V <sub>CC</sub> = Min, I <sub>OL</sub> = 2.1 mA	-	-	0.4	-	-	0.4	V	
V <sub>IH</sub>	Input HIGH voltage		2.2	-	V <sub>CC</sub> + 0.5	2.2	-	V <sub>CC</sub> + 0.5	V	
V <sub>IL</sub>	Input LOW voltage		-0.5	-	0.8	-0.5	-	0.8	V	
I <sub>IX</sub>	Input leakage current	GND ≤ V <sub>I</sub> ≤ V <sub>CC</sub>	-0.5	-	+0.5	-0.5	-	+0.5	µA	
I <sub>OZ</sub>	Output leakage current	GND ≤ V <sub>O</sub> ≤ V <sub>CC</sub> , output disabled	-0.5	-	+0.5	-0.5	-	+0.5	µA	
I <sub>CC</sub>	V <sub>CC</sub> operating supply current	V <sub>CC</sub> = Max, I <sub>OUT</sub> = 0 mA, f = f <sub>MAX</sub> = 1/t <sub>RC</sub>	LL - Commercial	-	-	-	-	25	50	mA
			LL - Industrial	-	25	50	-	25	50	mA
			LL - Automotive-A	-	25	50	-	25	50	mA
			LL - Automotive-E	-	25	50	-	-	-	mA
I <sub>SB1</sub>	Automatic CE power-down current – TTL inputs	Max. V <sub>CC</sub> , CE ≥ V <sub>IH</sub> , V <sub>IN</sub> ≥ V <sub>IH</sub> or V <sub>IN</sub> ≤ V <sub>IL</sub> , f = f <sub>MAX</sub>	LL - Commercial	-	-	-	-	0.3	0.5	mA
			LL - Industrial	-	0.3	0.5	-	0.3	0.5	mA
			LL - Automotive-A	-	0.3	0.5	-	0.3	0.5	mA
			LL - Automotive-E	-	0.3	0.5	-	-	-	mA
I <sub>SB2</sub>	Automatic CE power-down current – CMOS inputs	Max. V <sub>CC</sub> , CE ≥ V <sub>CC</sub> - 0.3 V, V <sub>IN</sub> ≥ V <sub>CC</sub> - 0.3 V, or V <sub>IN</sub> ≤ 0.3 V, f = 0	LL - Commercial	-	-	-	-	0.1	5	µA
			LL - Industrial	-	0.1	10	-	0.1	10	µA
			LL - Automotive-A	-	0.1	10	-	0.1	10	µA
			LL - Automotive-E	-	0.1	15	-	-	-	µA

**Notes**

2. V<sub>IL</sub> (min) = -2.0 V for pulse durations of less than 20 ns.
3. T<sub>A</sub> is the "Instant-On" case temperature.
4. Typical specifications are the mean values measured over a large sample size across normal production process variations and are taken at nominal conditions (T<sub>A</sub> = 25 °C, V<sub>CC</sub>). Parameters are guaranteed by design and characterization, and not 100% tested.

### Capacitance

Parameter <sup>[5]</sup>	Description	Test Conditions	Max	Unit
C <sub>IN</sub>	Input capacitance	T <sub>A</sub> = 25 °C, f = 1 MHz, V <sub>CC</sub> = 5.0 V	6	pF
C <sub>OUT</sub>	Output capacitance		8	pF

### Thermal Resistance

Parameter <sup>[5]</sup>	Description	Test Conditions	DIP	SOIC	TSOP	RTSOP	Unit
θ <sub>JA</sub>	Thermal resistance (junction to ambient)	Still air, soldered on a 4.25 × 1.125 inch, 4-layer printed circuit board	75.61	76.56	93.89	93.89	°C/W
θ <sub>JC</sub>	Thermal resistance (junction to case)		43.12	36.07	24.64	24.64	°C/W

### AC Test Loads and Waveforms

Figure 3. AC Test Loads and Waveforms

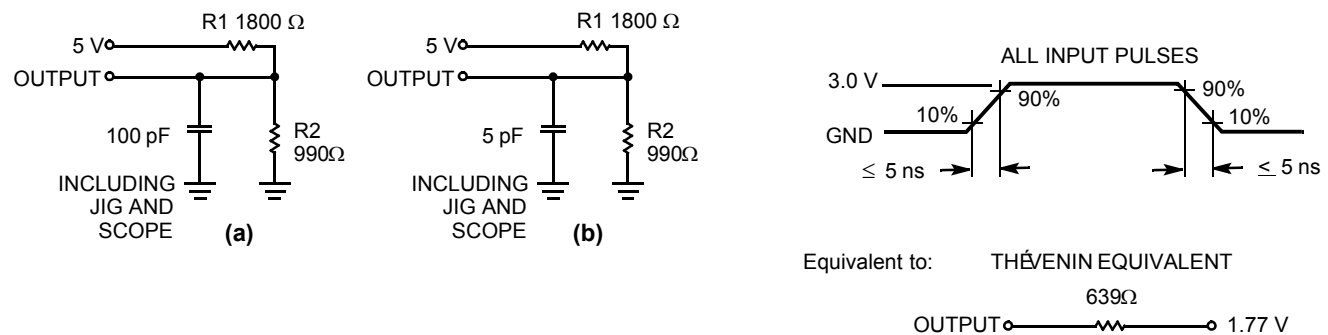

**Note**

5. Tested initially and after any design or process changes that may affect these parameters.

**Data Retention Characteristics**

Parameter	Description	Conditions <sup>[6]</sup>	Min	Typ <sup>[7]</sup>	Max	Unit	
V <sub>DR</sub>	V <sub>CC</sub> for data retention		2.0	–	–	V	
I <sub>CCDR</sub>	Data retention current	LL – Commercial	V <sub>CC</sub> = 2.0 V, CE ≥ V <sub>CC</sub> – 0.3 V, V <sub>IN</sub> ≥ V <sub>CC</sub> – 0.3 V, or V <sub>IN</sub> ≤ 0.3 V	–	0.1	5	μA
		LL – Industrial/ Automotive-A		–	0.1	10	μA
		LL – Automotive-E		–	0.1	10	μA
t <sub>CDR</sub> <sup>[7]</sup>	Chip deselect to data retention time		0	–	–	ns	
t <sub>R</sub> <sup>[7]</sup>	Operation recovery time	CY62256NLL-55	55	–	–	ns	
		CY62256NLL-70	70	–	–		

**Data Retention Waveform**

Figure 4. Data Retention Waveform

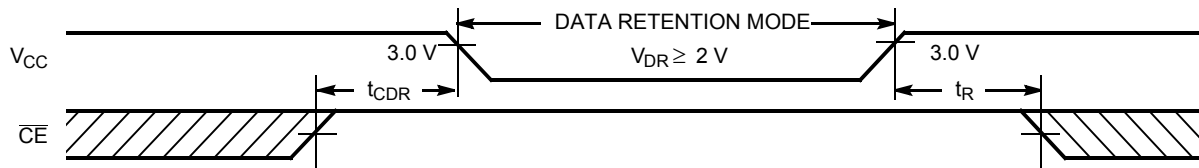

**Notes**

- 6. No input may exceed V<sub>CC</sub> + 0.5 V.
- 7. Typical specifications are the mean values measured over a large sample size across normal production process variations and are taken at nominal conditions (T<sub>A</sub> = 25 °C, V<sub>CC</sub>). Parameters are guaranteed by design and characterization, and not 100% tested.

## Switching Characteristics

Over the Operating Range

Parameter <sup>[8]</sup>	Description	CY62256N-55		CY62256N-70		Unit
		Min	Max	Min	Max	
<b>Read Cycle</b>						
$t_{RC}$	Read cycle time	55	–	70	–	ns
$t_{AA}$	Address to data valid	–	55	–	70	ns
$t_{OHA}$	Data hold from address change	5	–	5	–	ns
$t_{ACE}$	$\overline{CE}$ LOW to data valid	–	55	–	70	ns
$t_{DOE}$	$\overline{OE}$ LOW to data valid	–	25	–	35	ns
$t_{LZOE}$	$\overline{OE}$ LOW to low Z <sup>[9]</sup>	5	–	5	–	ns
$t_{HZOE}$	$\overline{OE}$ HIGH to high Z <sup>[9, 10]</sup>	–	20	–	25	ns
$t_{LZCE}$	$\overline{CE}$ LOW to low Z <sup>[9]</sup>	5	–	5	–	ns
$t_{HZCE}$	$\overline{CE}$ HIGH to high Z <sup>[9, 10]</sup>	–	20	–	25	ns
$t_{PU}$	$\overline{CE}$ LOW to power-up	0	–	0	–	ns
$t_{PD}$	$\overline{CE}$ HIGH to power-down	–	55	–	70	ns
<b>Write Cycle <sup>[11, 12]</sup></b>						
$t_{WC}$	Write cycle time	55	–	70	–	ns
$t_{SCE}$	$\overline{CE}$ LOW to write end	45	–	60	–	ns
$t_{AW}$	Address setup to write end	45	–	60	–	ns
$t_{HA}$	Address hold from write end	0	–	0	–	ns
$t_{SA}$	Address setup to write start	0	–	0	–	ns
$t_{PWE}$	$\overline{WE}$ pulse width	40	–	50	–	ns
$t_{SD}$	Data setup to write end	25	–	30	–	ns
$t_{HD}$	Data hold from write end	0	–	0	–	ns
$t_{HZWE}$	$\overline{WE}$ LOW to high Z <sup>[9, 10]</sup>	–	20	–	25	ns
$t_{LZWE}$	$\overline{WE}$ HIGH to low Z <sup>[9]</sup>	5	–	5	–	ns

### Notes

8. Test conditions assume signal transition time of 5 ns or less, timing reference levels of 1.5 V, input pulse levels of 0 to 3.0 V, and output loading of the specified  $I_{OL}/I_{OH}$  and 100-pF load capacitance.
9. At any temperature and voltage condition,  $t_{HZCE}$  is less than  $t_{LZCE}$ ,  $t_{HZOE}$  is less than  $t_{LZOE}$ , and  $t_{HZWE}$  is less than  $t_{LZWE}$  for any device.
10.  $t_{HZOE}$ ,  $t_{HZCE}$ , and  $t_{HZWE}$  are specified with  $C_L = 5$  pF as in (b) of AC Test Loads. Transition is measured  $\pm 500$  mV from steady-state voltage.
11. The internal Write time of the memory is defined by the overlap of  $\overline{CE}$  LOW and  $\overline{WE}$  LOW. Both signals must be LOW to initiate a Write and either signal can terminate a Write by going HIGH. The data input setup and hold timing should be referenced to the rising edge of the signal that terminates the Write.
12. The minimum Write cycle time for Write Cycle #3 ( $\overline{WE}$  controlled,  $\overline{OE}$  LOW) is the sum of  $t_{HZWE}$  and  $t_{SD}$ .

### Switching Waveforms

Figure 5. Read Cycle No. 1 [13, 14]

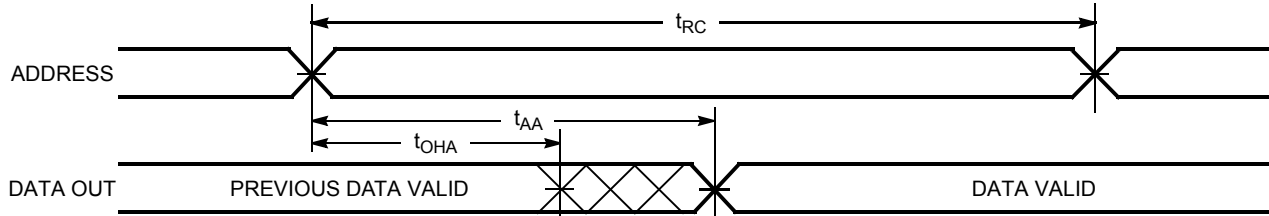
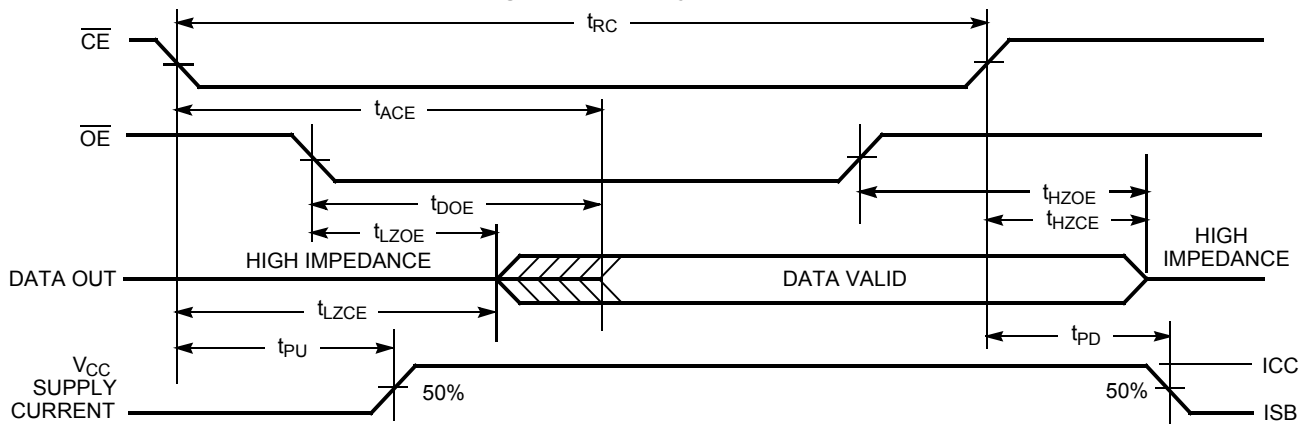

Figure 6. Read Cycle No. 2 [14, 15]



**Notes**

- 13. Device is continuously selected.  $\overline{OE}, \overline{CE} = V_{IL}$ .
- 14.  $\overline{WE}$  is HIGH for Read cycle.
- 15. Address valid prior to or coincident with  $\overline{CE}$  transition LOW.

Switching Waveforms (continued)

Figure 7. Write Cycle No. 1 ( $\overline{WE}$  Controlled) [16, 17, 18]

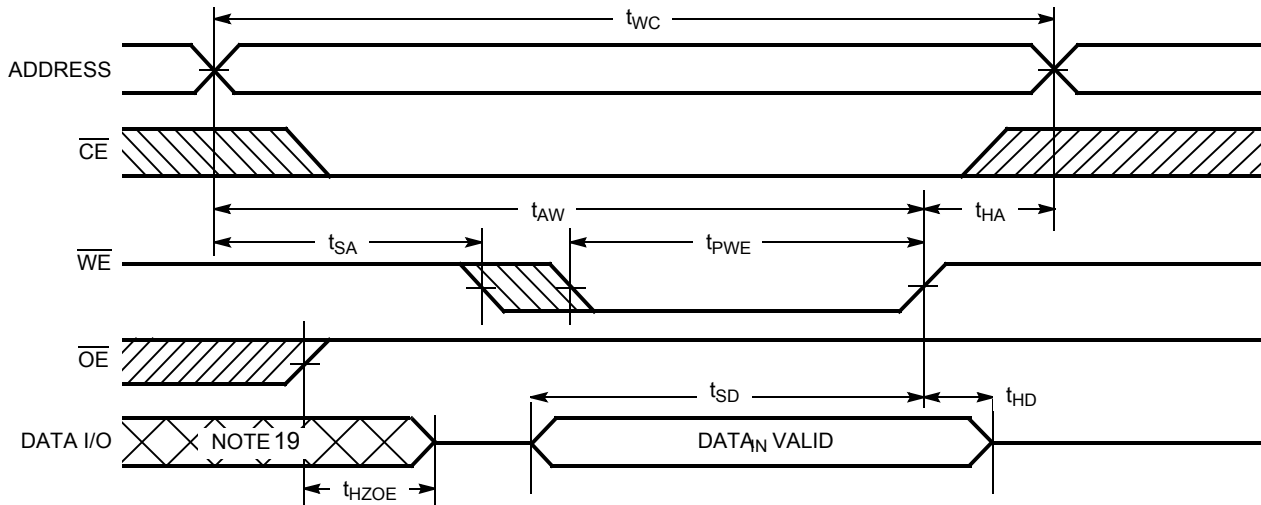

Figure 8. Write Cycle No. 2 ( $\overline{CE}$  Controlled) [16, 17, 18]

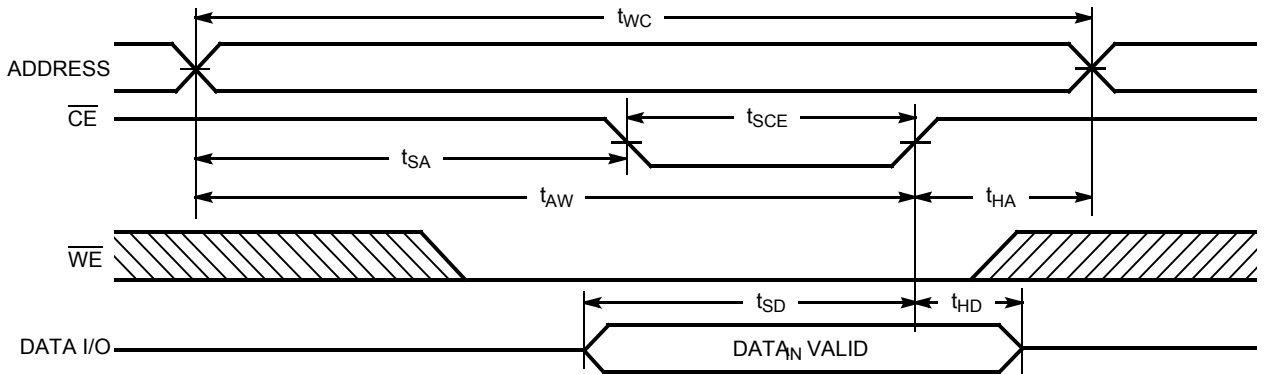
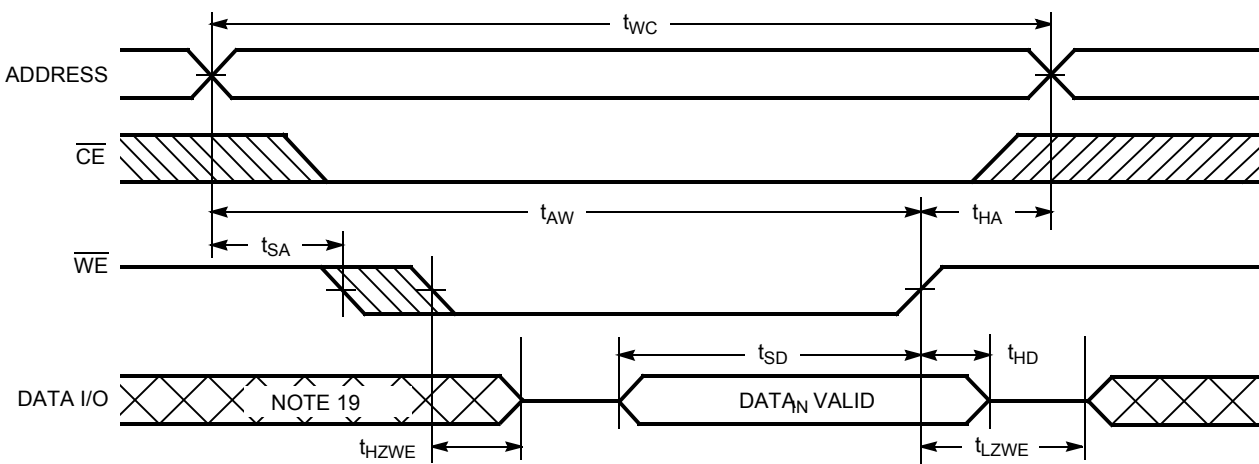

Figure 9. Write Cycle No. 3 ( $\overline{WE}$  Controlled,  $\overline{OE}$  LOW) [18, 20]



Notes

- 16. The internal Write time of the memory is defined by the overlap of  $\overline{CE}$  LOW and  $\overline{WE}$  LOW. Both signals must be LOW to initiate a Write and either signal can terminate a Write by going HIGH. The data input setup and hold timing should be referenced to the rising edge of the signal that terminates the Write.
- 17. Data I/O is high impedance if  $OE = V_{IH}$ .
- 18. If CE goes HIGH simultaneously with WE HIGH, the output remains in a high-impedance state.
- 19. During this period, the I/Os are in output state and input signals should not be applied.
- 20. The minimum Write cycle time for Write Cycle #3 (WE controlled, OE LOW) is the sum of  $t_{HZWE}$  and  $t_{SD}$ .

Typical DC and AC Characteristics

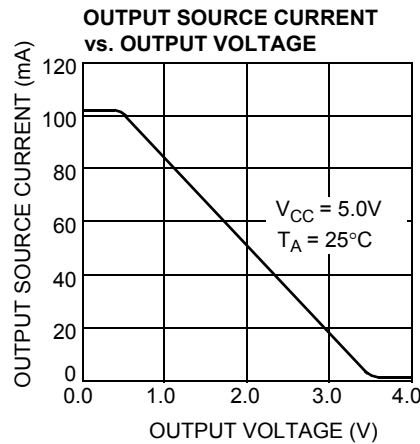
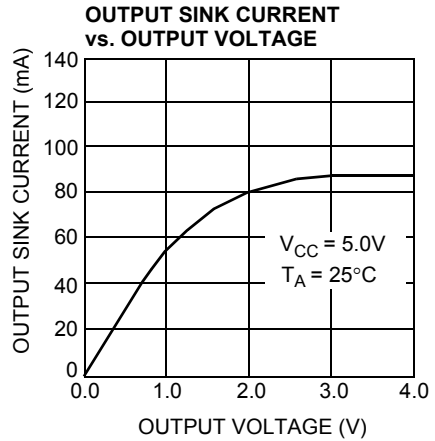
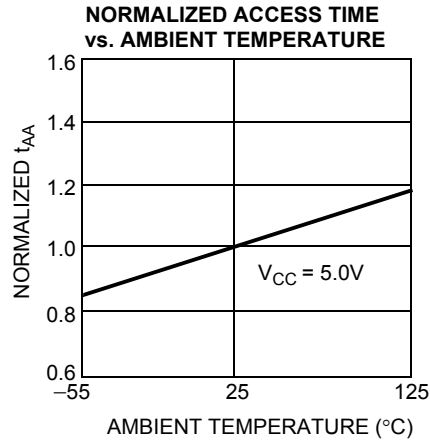
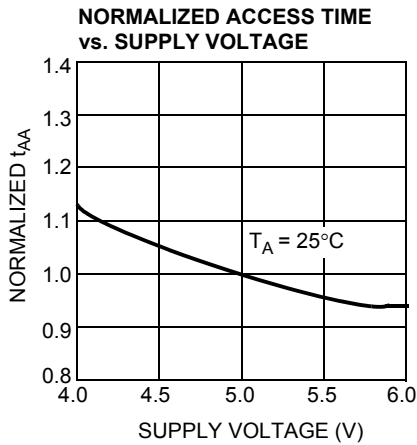
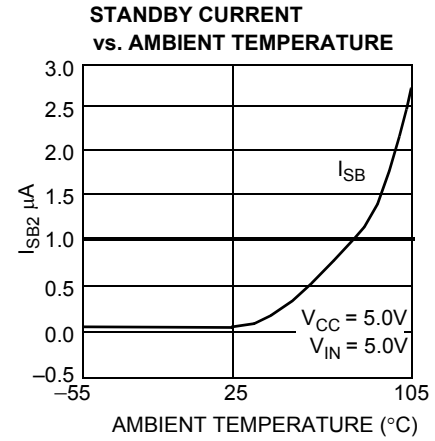
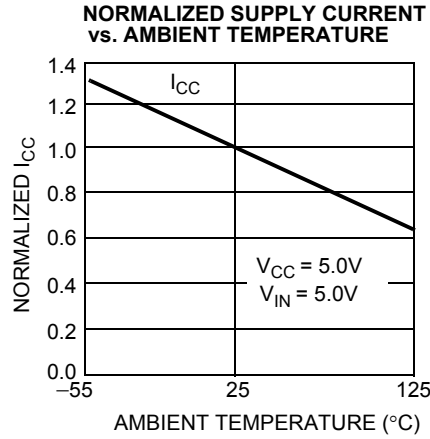
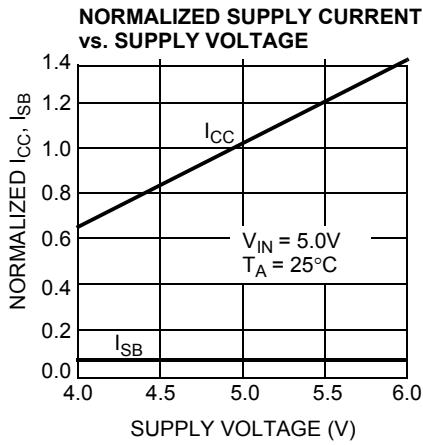

Typical DC and AC Characteristics (continued)

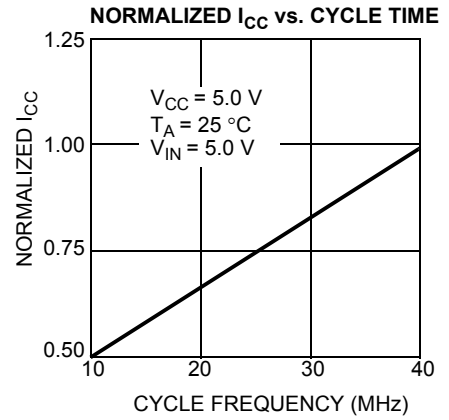
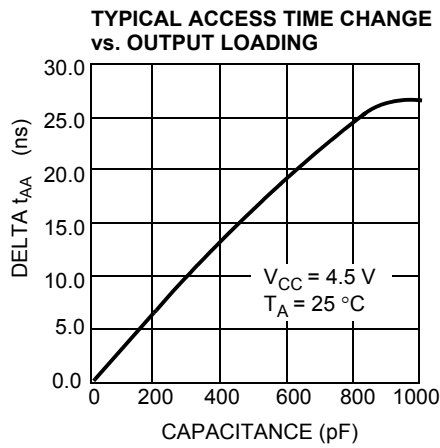
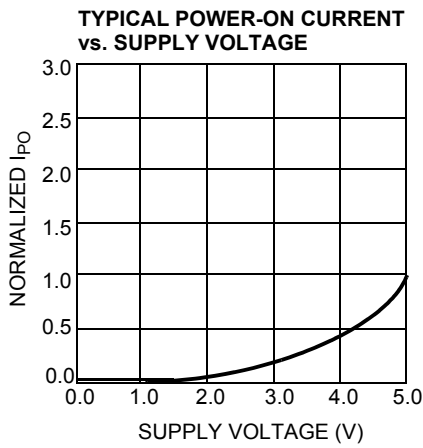

Truth Table

$\overline{\text{CE}}$	$\overline{\text{WE}}$	$\overline{\text{OE}}$	Inputs/Outputs	Mode	Power
H	X	X	High Z	Deselect/power-down	Standby (I <sub>SB</sub> )
L	H	L	Data Out	Read	Active (I <sub>CC</sub> )
L	L	X	Data In	Write	Active (I <sub>CC</sub> )
L	H	H	High Z	Output Disabled	Active (I <sub>CC</sub> )

**Ordering Information**

Speed (ns)	Ordering Code	Package Diagram	Package Type	Operating Range
55	CY62256NLL-55SNXI	51-85092	28-pin SNC (300 Mils) Narrow Body (Pb-free)	Industrial
	CY62256NLL-55ZXI	51-85071	28-pin TSOP I (Pb-free)	
	CY62256NLL-55ZXAX	51-85071	28-pin TSOP I (Pb-free)	Automotive-A
	CY62256NLL-55SNXE	51-85092	28-pin SNC (300 Mils) Narrow Body (Pb-free)	Automotive-E
	CY62256NLL-55ZXEX	51-85071	28-pin TSOP I (Pb-free)	
70	CY62256NLL-70PXC	51-85017	28-pin (600 Mil) Molded DIP (Pb-free)	Commercial
	CY62256NLL-70SNXC	51-85092	28-pin SNC (300 Mils) Narrow Body (Pb-free)	
	CY62256NLL-70ZRXI	51-85074	28-pin Reverse TSOP I (Pb-free)	Industrial
	CY62256NLL-70SNXA	51-85092	28-pin SNC (300 Mils) Narrow Body (Pb-free)	Automotive-A

**Ordering Code Definitions**

CY 62 256 N LL - XX XXX X

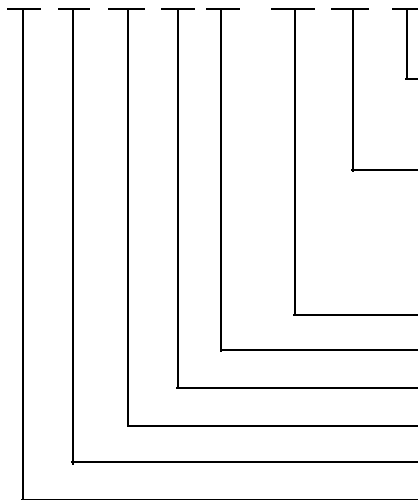

- Temperature Grade: X = C or I or A or E  
 C = Commercial = 0 °C to +70 °C; I = Industrial = -40 °C to +85 °C;  
 A = Automotive-A = -40 °C to +85 °C; E = Automotive-E = -40 °C to +125 °C
- Package Type: XXX = SNX or ZX or PX or ZRX  
 SNX = 28-pin SNC (Pb-free)  
 ZX = 28-pin TSOP I (Pb-free)  
 PX = 28-pin Molded DIP (Pb-free)  
 ZRX = 28-pin Reverse TSOP I (Pb-free)
- Speed Grade: XX = 55 ns or 70 ns
- Low Power
- Nitride Seal Mask fix
- Density: 256 kbit
- Family Code: MoBL SRAM family
- Company ID: CY = Cypress

Package Diagrams

Figure 10. 28-pin PDIP (1.480 × 0.550 × 0.195 Inches) P28.6/PZ28.6 Package Outline, 51-85017

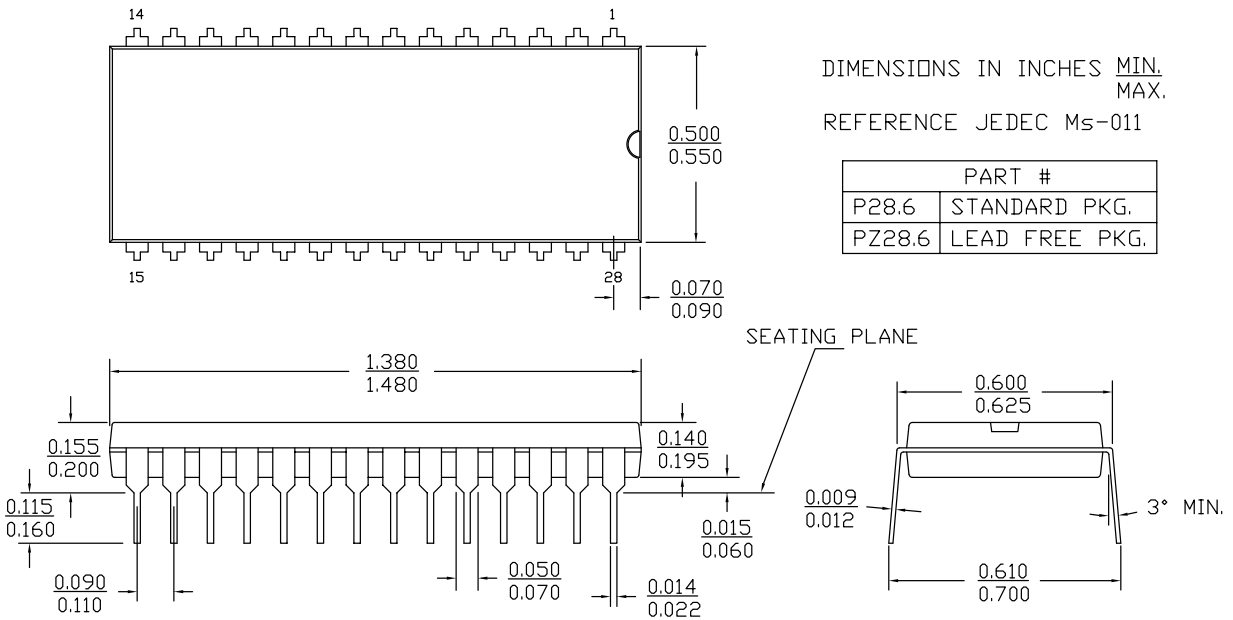

51-85017 \*E

Figure 11. 28-pin SNC (300 Mils) SN28.3 (Narrow Body) Package Outline, 51-85092

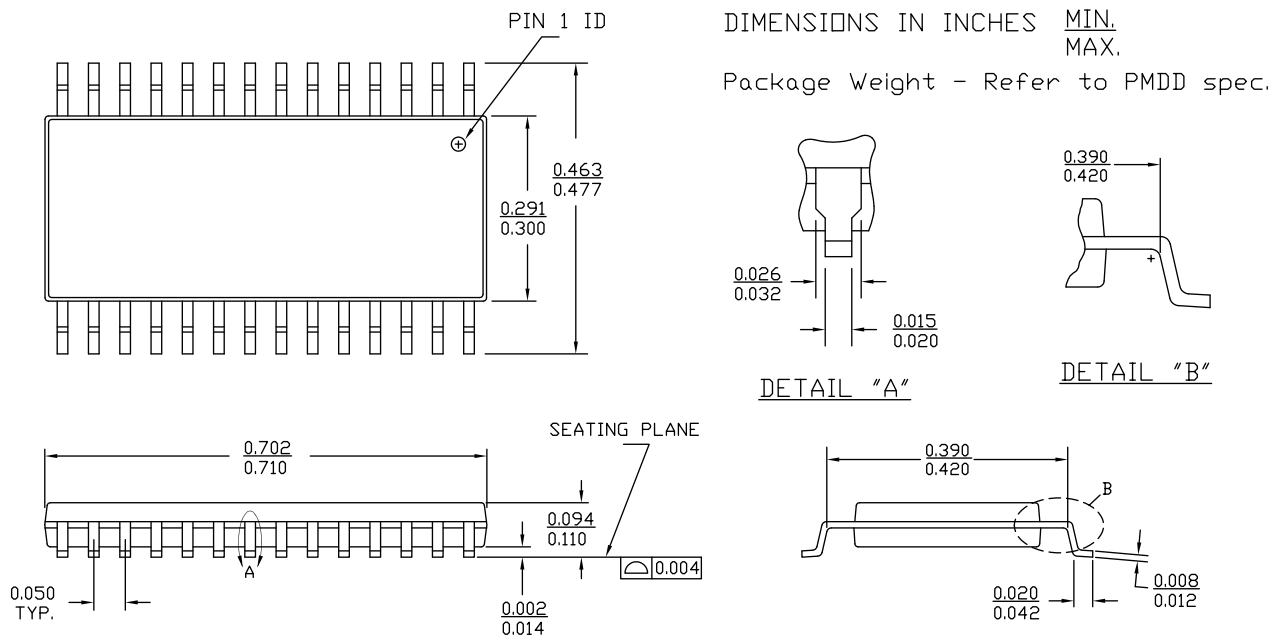

51-85092 \*E

Package Diagrams (continued)

Figure 12. 28-pin TSOP I (8 × 13.4 × 1.2 mm) Z28 (Standard) Package Outline, 51-85071

NOTE: ORIENTATION I.D. MAY BE LOCATED EITHER AS SHOWN IN OPTION 1 OR OPTION 2

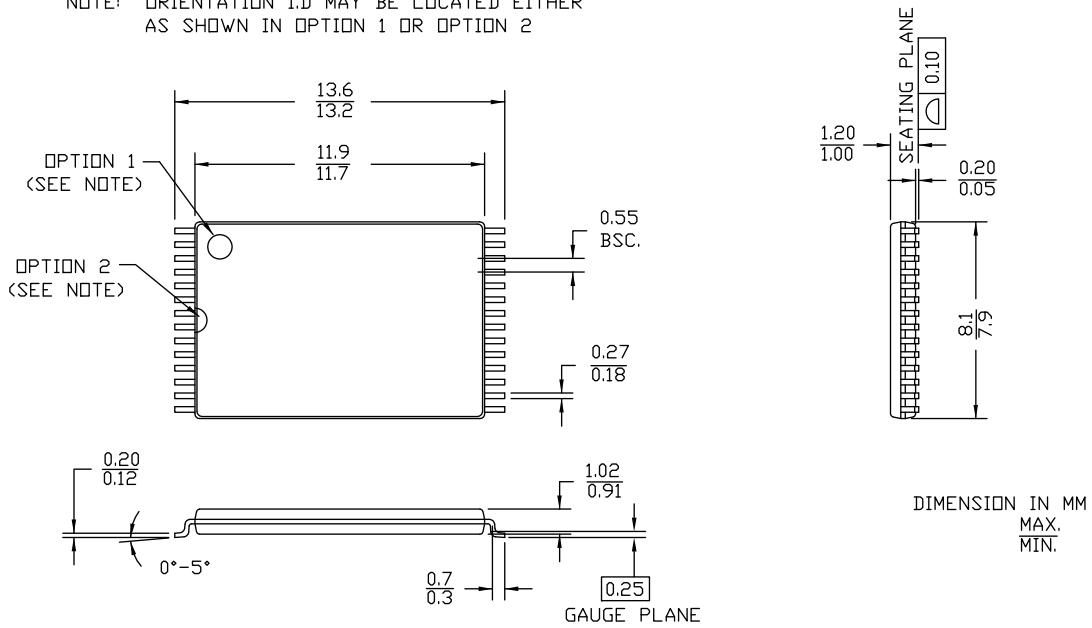

51-85071 \*I

Figure 13. 28-pin TSOP I (8 × 13.4 mm) Package Outline - Reverse, 51-85074

NOTE: ORIENTATION I.D. MAY BE LOCATED EITHER AS SHOWN IN OPTION 1 OR OPTION 2

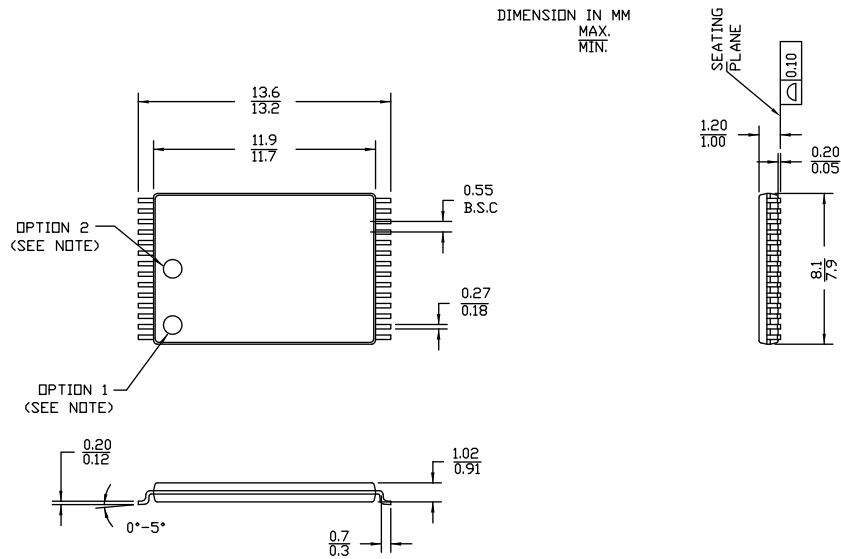

51-85074 \*G

## Acronyms

Acronym	Description
CMOS	Complementary Metal Oxide Semiconductor
I/O	Input/Output
SRAM	Static Random Access Memory
TSOP	Thin Small Outline Package
VFBGA	Very Fine-Pitch Ball Grid Array

## Document Conventions

### Units of Measure

Symbol	Unit of Measure
°C	degree Celsius
μA	microampere
mA	milliampere
MHz	megahertz
ns	nanosecond
Ω	ohm
pF	picofarad
V	volt
W	watt

**Document History Page**

Document Title: CY62256N, 256-Kbit (32 K × 8) Static RAM Document Number: 001-06511				
Revision	ECN	Orig. of Change	Submission Date	Description of Change
**	426504	NXR	See ECN	New data sheet.
*A	488954	NXR	See ECN	Added Automotive product Updated ordering Information table
*B	2715270	VKN / AESA	06/05/2009	Updated POD of 28-Pin (600-Mil) Molded DIP package (Spec# 51-85017)
*C	2891344	VKN	03/12/2010	Added Table of Contents Removed "L" product information Updated Ordering Information table Updated Package Diagrams (Figure 10, Figure 11, and Figure 12) Updated Sales, Solutions, and Legal Information
*D	3119519	AJU	01/04/2011	Updated <a href="#">Ordering Information</a> . Added <a href="#">Ordering Code Definitions</a> .
*E	3329873	RAME	07/27/11	Updated template and styles according to current Cypress standards. Added acronyms and units. Removed reference to AN1064 SRAM system guidelines. Updated operation recovery time parameter under <a href="#">Data Retention Characteristics on page 6</a> .
*F	3433878	TAVA	11/09/11	Updated package diagrams.
*G	4122787	VINI	09/13/2013	Updated <a href="#">Package Diagrams</a> : spec 51-85092 – Changed revision from *D to *E.  Updated in new template.  Completing Sunset Review.

## Sales, Solutions, and Legal Information

### Worldwide Sales and Design Support

Cypress maintains a worldwide network of offices, solution centers, manufacturer's representatives, and distributors. To find the office closest to you, visit us at [Cypress Locations](#).

#### Products

<a href="#">Automotive</a>	<a href="#">cypress.com/go/automotive</a>
<a href="#">Clocks &amp; Buffers</a>	<a href="#">cypress.com/go/clocks</a>
<a href="#">Interface</a>	<a href="#">cypress.com/go/interface</a>
<a href="#">Lighting &amp; Power Control</a>	<a href="#">cypress.com/go/powerpsoc</a> <a href="#">cypress.com/go/plc</a>
<a href="#">Memory</a>	<a href="#">cypress.com/go/memory</a>
<a href="#">PSoC</a>	<a href="#">cypress.com/go/psoc</a>
<a href="#">Touch Sensing</a>	<a href="#">cypress.com/go/touch</a>
<a href="#">USB Controllers</a>	<a href="#">cypress.com/go/USB</a>
<a href="#">Wireless/RF</a>	<a href="#">cypress.com/go/wireless</a>

#### PSoC<sup>®</sup> Solutions

[psoc.cypress.com/solutions](#)  
[PSoC 1](#) | [PSoC 3](#) | [PSoC 4](#) | [PSoC 5LP](#)

#### Cypress Developer Community

[Community](#) | [Forums](#) | [Blogs](#) | [Video](#) | [Training](#)

#### Technical Support

[cypress.com/go/support](#)

---

© Cypress Semiconductor Corporation, 2006-2013. The information contained herein is subject to change without notice. Cypress Semiconductor Corporation assumes no responsibility for the use of any circuitry other than circuitry embodied in a Cypress product. Nor does it convey or imply any license under patent or other rights. Cypress products are not warranted nor intended to be used for medical, life support, life saving, critical control or safety applications, unless pursuant to an express written agreement with Cypress. Furthermore, Cypress does not authorize its products for use as critical components in life-support systems where a malfunction or failure may reasonably be expected to result in significant injury to the user. The inclusion of Cypress products in life-support systems application implies that the manufacturer assumes all risk of such use and in doing so indemnifies Cypress against all charges.

Any Source Code (software and/or firmware) is owned by Cypress Semiconductor Corporation (Cypress) and is protected by and subject to worldwide patent protection (United States and foreign), United States copyright laws and international treaty provisions. Cypress hereby grants to licensee a personal, non-exclusive, non-transferable license to copy, use, modify, create derivative works of, and compile the Cypress Source Code and derivative works for the sole purpose of creating custom software and or firmware in support of licensee product to be used only in conjunction with a Cypress integrated circuit as specified in the applicable agreement. Any reproduction, modification, translation, compilation, or representation of this Source Code except as specified above is prohibited without the express written permission of Cypress.

Disclaimer: CYPRESS MAKES NO WARRANTY OF ANY KIND, EXPRESS OR IMPLIED, WITH REGARD TO THIS MATERIAL, INCLUDING, BUT NOT LIMITED TO, THE IMPLIED WARRANTIES OF MERCHANTABILITY AND FITNESS FOR A PARTICULAR PURPOSE. Cypress reserves the right to make changes without further notice to the materials described herein. Cypress does not assume any liability arising out of the application or use of any product or circuit described herein. Cypress does not authorize its products for use as critical components in life-support systems where a malfunction or failure may reasonably be expected to result in significant injury to the user. The inclusion of Cypress' product in a life-support systems application implies that the manufacturer assumes all risk of such use and in doing so indemnifies Cypress against all charges.

Use may be limited by and subject to the applicable Cypress software license agreement.



LittleDiode supplies new, hard to find or obsolete electronic components and semiconductors all over the world.

With over two million different components listed you are sure to find the part you need.

Feel free to visit us today at our online store:

[LittleDiode.com](http://LittleDiode.com)

Looking forward to providing you with the best possible service.