

Description

The AP1506 series are monolithic IC designed for a step-down DC/DC converter, and own the ability of driving a 3A load without external transistor. Due to reducing the number of external components, the board space can be saved easily. The external shutdown function can be controlled by logic level and then come into standby mode. The internal compensation makes feedback control have good line and load regulation without external design. Regarding protected function, thermal shutdown is to prevent over temperature operating from damage, and current limit is to prevent over current operating of the output switch. If current limit function occurred and V_{FB} is down to 0.5V below, the switching frequency will be reduced. The AP1506 series operate at a switching frequency of 150KHz thus allowing smaller sized filter components than what would be needed with lower frequency switching regulators. Other features include a guaranteed $\pm 4\%$ tolerance on output voltage under specified input voltage and output load conditions, and $\pm 15\%$ on the oscillator frequency. The output version included fixed 3.3V, 5V, 12V, and an adjustable type. The packages are available in a standard 5-lead TO263 and TO220.

Features

- Output Voltage: 3.3V, 5V, 12V and Adjustable Output Version
- Adjustable Version Output Voltage Range, 1.23V to 18V+4%
- 150KHz +15% Fixed Switching Frequency
- Voltage Mode Non-Synchronous PWM Control
- Thermal-Shutdown and Current-Limit Protection
- ON/OFF Shutdown Control Input
- Operating Voltage can be up to 22V
- Output Load Current: 3A
- Lead Free packages: TO263-5L and TO220-5L(R)
- TO263-5L and TO220-5L(R): Available in "Green" Molding Compound (No Br, Sb)
- Low Power standby mode
- Built-in Switching Transistor On Chip
- Lead Free Finish/RoHS Compliant (Note 1)

Notes: 1. EU Directive 2002/95/EC (RoHS). All applicable RoHS exemptions applied. Please visit our website at http://www.diodes.com/products/lead_free.html.

Pin Assignments

(Top View)

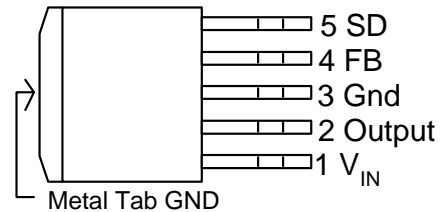

TO263-5L

(Top View)

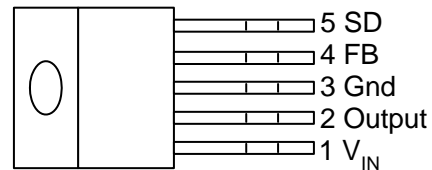

TO220-5L/TO220-5L(R)

Applications

- Simple High-Efficiency Step-Down Regulator
- On-Card Switching Regulators
- Positive to Negative Converter

Typical Application Circuit

(1) Fixed Type Circuit

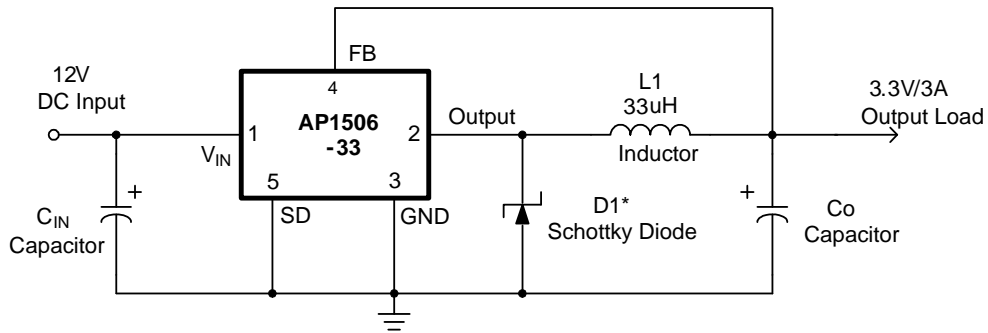

(2) Adjustable Type Circuit

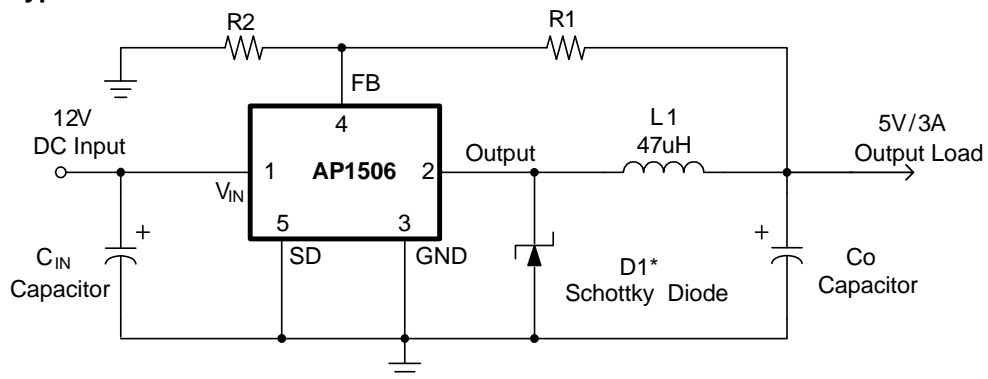

$$V_{out} = V_{FB} \times \left(1 + \frac{R1}{R2}\right)$$

$$V_{FB} = 1.23V$$

$$R2 = 1K \sim 3K$$

(3) Delay Start Circuit

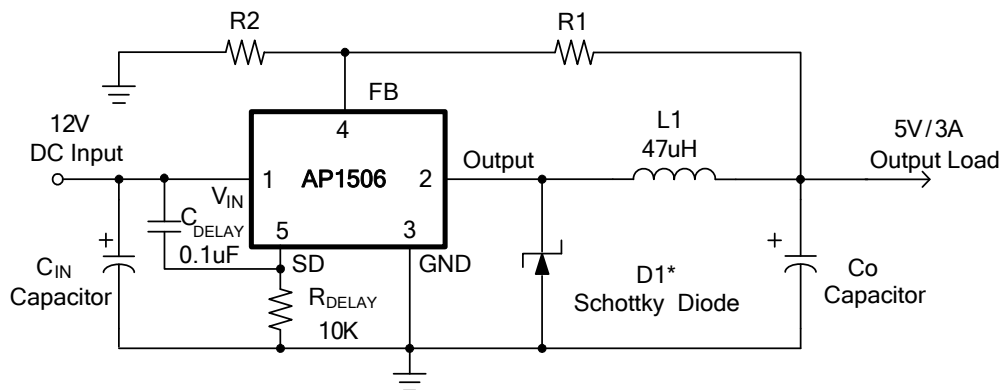

Notes: 2. For up to 2A = DFLS230L ($V_f = 0.42V$)
For up to 3A = B340LA, B340LB ($V_f = 0.45V$)

Pin Descriptions

Pin Name	Description
V _{IN}	Operating Voltage Input
Output	Switching Output
GND	Ground
FB	Output Voltage Feedback Control
SD	ON/OFF Shutdown

Functional Block Diagram

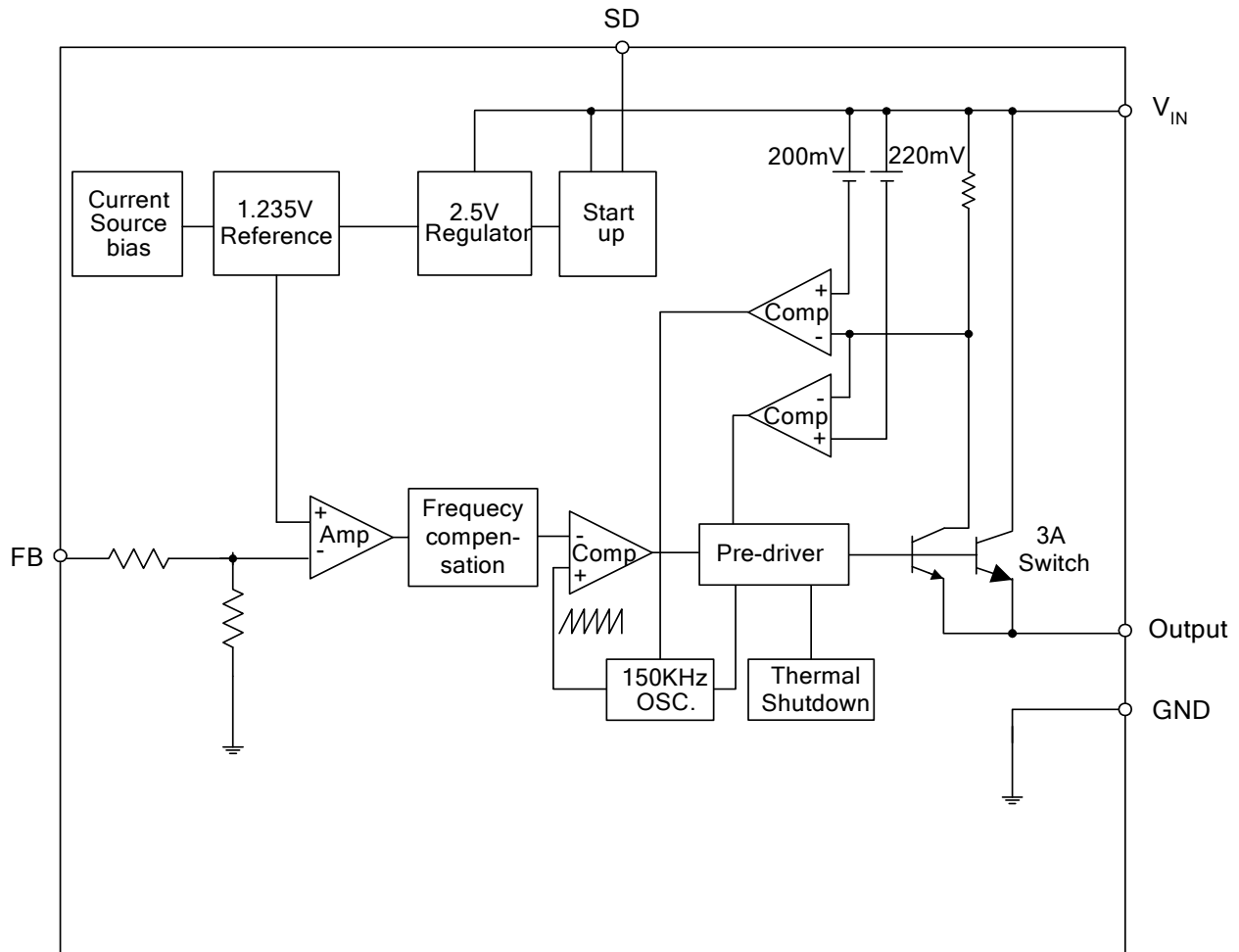

Absolute Maximum Ratings

Symbol	Parameter	Rating	Unit
ESD MM	Machine Model ESD Protection	400	V
V_{CC}	Supply Voltage	+24	V
V_{SD}	ON/OFF Pin Input Voltage	-0.3 to +18	V
V_{FB}	Feedback Pin Voltage	-0.3 to +18	V
V_{OUT}	Output Voltage to Ground	-1	V
P_D	Power Dissipation	Internally Limited	W
T_{ST}	Storage Temperature	-65 to +150	°C
T_{OP}	Operating Junction Temperature	-40 to +125	°C

Recommended Operating Conditions

Symbol	Parameter	Min	Max	Unit
V_{OP}	Operating Voltage	4.5	22	V
T_A	Operating Ambient Temperature	-20	85	°C

Electrical Characteristics (All Output Voltage Versions)

Unless otherwise specified, $V_{IN} = 12V$ for 3.3V, 5V, adjustable version and $V_{IN} = 18V$ for the 12V version. $I_{LOAD} = 0.5A$
 Specifications with **boldface type** are for full operating temperature range, the other type are for $T_J = 25^\circ C$.

Symbol	Parameter		Conditions	Min	Typ.	Max	Unit
I_{FB}	Feedback Bias Current		$V_{FB} = 1.3V$ (Adjustable version only)	-	-10	-50 -100	nA
F_{OSC}	Oscillator Frequency			127 110	150 -	173 173	KHz
F_{SCP}	Oscillator Frequency of Short Circuit Protect		When current limit occurred and $V_{FB} < 0.5V$, $T_a = 25^\circ C$	10	30	50	KHz
V_{SAT}	Saturation Voltage		$I_{OUT} = 3A$ No outside circuit $V_{FB} = 0V$ force driver on	-	1.4	1.6 1.7	V
DC	Max. Duty Cycle (ON)		$V_{FB} = 0V$ force driver on	-	100	-	%
	Min. Duty Cycle (OFF)		$V_{FB} = 12V$ force driver off	-	0	-	
I_{CL}	Current Limit		Peak current No outside circuit $V_{FB} = 0$ force driver on	3.6	4.5	5.5 6.5	A
I_L	Output = 0V	Output Leakage Current	No outside circuit $V_{FB} = 12$ force driver off	-	-	-200	μA
	Output = -1V		$V_{IN} = 22V$	-	-5	-	mA
I_Q	Quiescent Current		$V_{FB} = 12$ force driver off	-	5	10	mA
I_{STBY}	Standby Quiescent Current		ON/OFF pin = 5V $V_{IN} = 22V$	-	70	150 200	μA
V_{IL}	ON/OFF Pin Logic Input Threshold Voltage		Low (regulator ON)	-	1.3	0.6	V
V_{IH}			High (regulator OFF)	2.0		-	
I_H	ON/OFF Pin Logic Input Current		$V_{LOGIC} = 2.5V$ (OFF)	-	-	-0.01	μA
I_L	ON/OFF Pin Input Current		$V_{LOGIC} = 0.5V$ (ON)	-	-0.1	-1	
θ_{JA}	Thermal Resistance Junction to Ambient		TO263-5L (Note 3)		37	-	$^\circ C/W$
			TO220-5L(R) (Note 3)		31	-	
θ_{JC}	Thermal Resistance Junction to Case		TO263-5L (Note 3)		6	-	$^\circ C/W$
			TO220-5L(R) (Note 3)		5	-	

Notes: 3. Test condition: Device mounted with copper area of approximately 3 in^2 , no air flow.

Electrical Characteristics (Continued)

Specifications with **boldface** type are for full operating temperature range, the other type are for $T_J = 25^\circ\text{C}$.

	Symbol	Parameter	Conditions	V _{Min}	Typ.	V _{Max}	Unit
AP1506-ADJ	V _{FB}	Output Feedback	5V ≤ V _{IN} ≤ 22V 0.2A ≤ I _{LOAD} ≤ 3A V _{OUT} programmed for 3V	1.193	1.23	1.267	V
				1.18	-	1.28	
	η	Efficiency	V _{IN} = 12V, I _{LOAD} = 3A	-	74	-	%
AP1506-3.3V	V _{OUT}	Output Voltage	5.5V ≤ V _{IN} ≤ 22V 0.2A ≤ I _{LOAD} ≤ 3A	3.168	3.3	3.432	V
				3.135	-	3.465	
	η	Efficiency	V _{IN} = 12V, I _{LOAD} = 3A	-	75	-	%
AP1506-5V	V _{OUT}	Output Voltage	8V ≤ V _{IN} ≤ 22V 0.2A ≤ I _{LOAD} ≤ 3A	4.8	5	5.2	V
				4.75	-	5.25	
	η	Efficiency	V _{IN} = 12V, I _{LOAD} = 3A	-	80	-	%
AP1506-12V	V _{OUT}	Output Voltage	15V ≤ V _{IN} ≤ 22V 0.2A ≤ I _{LOAD} ≤ 3A	11.52	12	12.48	V
				11.4	-	12.6	
	η	Efficiency	V _{IN} = 16V, I _{LOAD} = 3A	-	89	-	%

Functional Description

Pin Functions

+V_{IN}

This is the positive input supply for the IC switching regulator. A suitable input bypass capacitor must be presented at this pin to minimize voltage transients and to supply the switching currents needed by the regulator.

Ground

Circuit ground.

Output

Internal switch. The voltage at this pin switches between (+V_{IN} - V_{SAT}) and approximately -0.5V, with a duty cycle of approximately V_{OUT} / V_{IN}. To minimize coupling to sensitive circuitry, the PC board copper area connected to this pin should be kept to a minimum.

Feedback (FB)

Senses the regulated output voltage to complete the feedback loop.

ON/OFF (SD)

Allows the switching regulator circuit to be shutdown using logic level signals thus dropping the total input supply current to approximately 150uA. Pulling this pin below a threshold voltage of approximately 1.3V turns the regulator on, and pulling this pin above 1.3V (up to a maximum of 18V) shuts the regulator down. If this shutdown feature is not needed, the ON / OFF pin can be wired to the ground pin.

Thermal Considerations

The AP1506 is available in two packages: a 5-pin TO220 and a 5-pin surface mount TO263.

The TO220 package needs a heat sink under most conditions. The size of the heat sink depends on the input voltage, the output voltage, the load current and the ambient temperature. The AP1506 junction temperature rises above ambient temperature for a 3A load and different input and output voltages. The data for these curves was taken with the AP1506 (TO220 package) operating as a buck-switching regulator in an ambient temperature of 25°C (still air). These temperature rise numbers are all approximate and there are many factors that can affect these temperatures. Higher ambient temperatures require more heat sinking.

The TO263 surface mount package tab was designed to be soldering to the copper on a printed circuit board. The copper and the board are the heat sink for this package and the other heat producing components, such as the catch diode and inductor. The PC board copper area that the package is soldered to should be at least 0.8 in², and ideally should have 2 or more square inches of 2 oz. Additional copper area improves the thermal characteristics, but with copper areas greater than approximately 6 in², only small improvements in heat dissipation are realized. If further thermal improvements are needed, double sided, multi-layer PC board with large copper areas and/or airflow will be recommended.

Functional Description (Continued)

The AP1506 (TO263 package) junction temperature rises above ambient temperature with a 2A load for various input and output voltages. This data was taken with the circuit operating as a buck-switching regulator with all components mounted on a PC board to simulate the junction temperature under actual operating conditions. This curve can be used for a quick check for the approximate junction temperature for various conditions, but be aware that there are many factors that can affect the junction temperature. When load currents higher than 3A are used, double sided or multi-layer PC boards with large copper areas and/or airflow might be needed, especially for high ambient temperatures and high output voltages.

For the best thermal performance, wide copper traces and generous amounts of printed circuit board copper should be used in the board layout (Once exception to this is the output (switch) pin, which should not have large areas of copper). Large areas of copper provide the best transfer of heat (lower thermal resistance) to the surrounding air, and moving air lowers the thermal resistance even further.

Package thermal resistance and junction temperature rise numbers are all approximate, and there are many factors that will affect these numbers. Some of these factors include board size, shape, thickness, position, location, and even board temperature. Other factors are: trace width, total printed circuit copper area, copper thickness, single or double-sided, multi-layer board and the amount of solder on the board. The effectiveness of the PC board to dissipate heat also depends on the size, quantity and spacing of other components on the board, as well as whether the surrounding air is still or moving. Furthermore, some of these components such as the catch diode will add heat to the PC board and the heat can vary as the input voltage changes. For the inductor, depending on the physical size, type of core material and the DC resistance, it could either act as a heat sink taking heat away from the board, or it could add heat to the board.

Typical Performance Characteristics

AP1506 Efficiency vs. Temperature
($V_{IN} = 12V, V_{OUT} = 5V, I_o = 3A$)

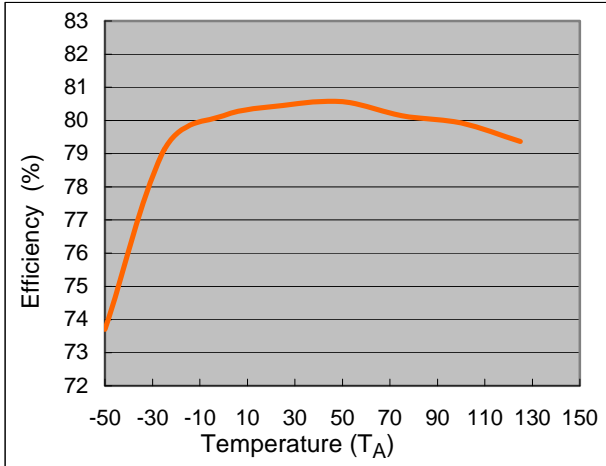

AP1506 Efficiency vs. Temperature
($V_{IN} = 12V, V_{OUT} = 3.3V, I_o = 3A$)

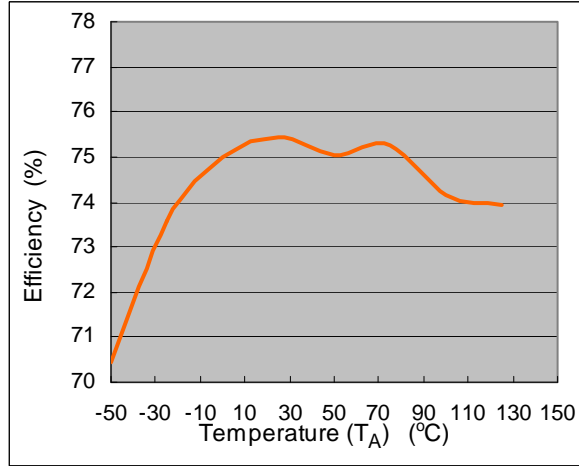

AP1506 Saturation Voltage vs. Temperature
($V_{CC} = 12V, V_{FB} = 0V, V_{SD} = 0$)

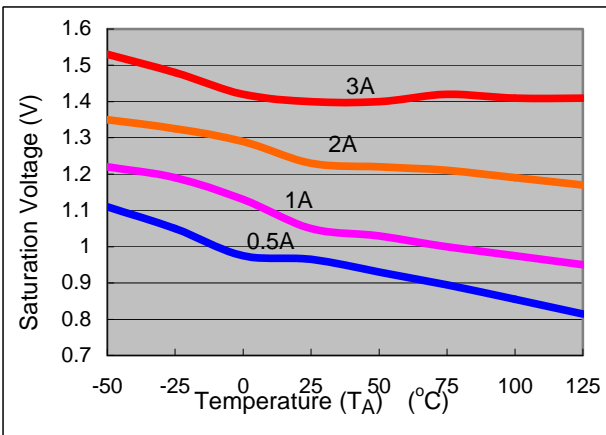

AP1506 Switch Current Limit vs. Temperature
($V_{CC} = 12V, V_{FB} = 0V$)

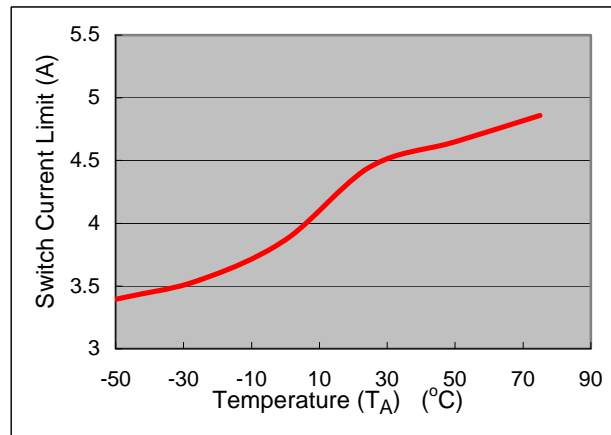

AP1506 Supply Current vs. Temperature
($V_{CC} = 12V, \text{No Load}, V_{on/off} = 0V \text{ (Switch ON)}, V_{on/off} = 5V \text{ (Switch OFF)}$)

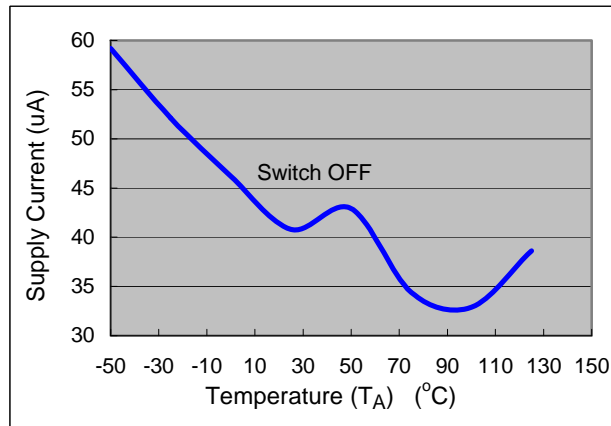
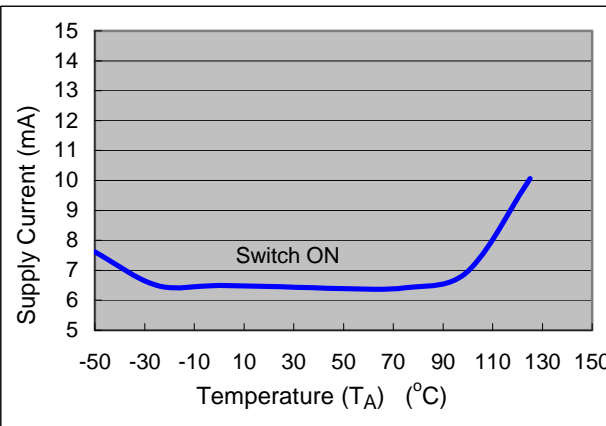

Typical Performance Characteristics (Continued)

AP1506 Threshold Voltage vs. Temperature
($V_{CC} = 12V$, $I_o = 100mA$)

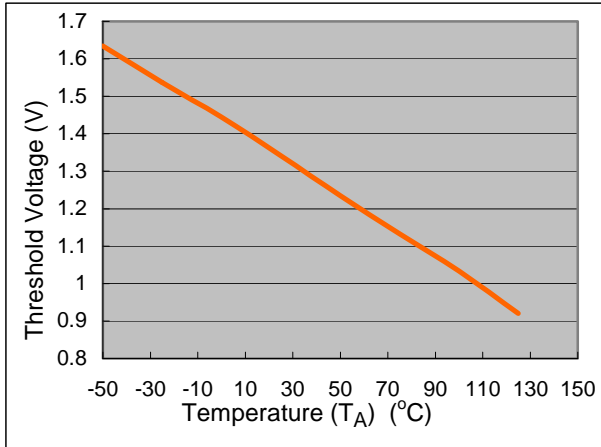

AP1506 ON/OFF Current vs. ON/OFF Voltage
($V_{IN} = 12V$)

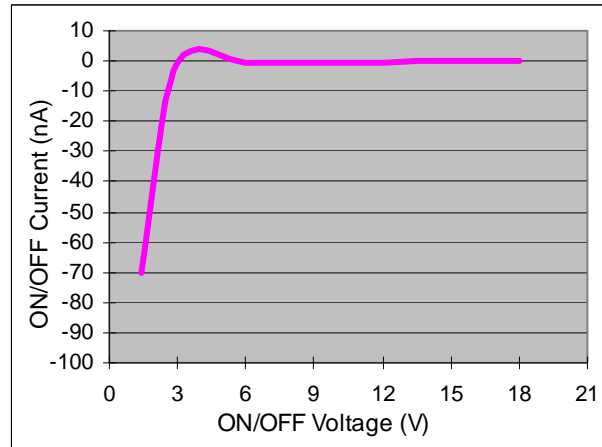

AP1506 Frequency vs. Temperature
($V_{CC} = 12V$, $I_c = 500mA$, $V_{OUT} = 5V$)

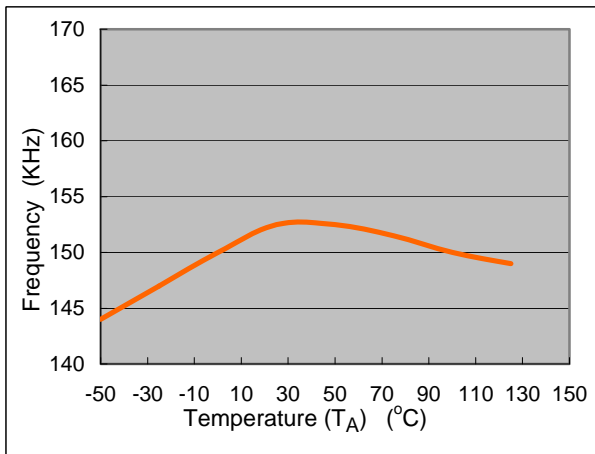

AP1506 Feedback Current vs. Temperature
($V_{CC} = 12V$, $V_{OUT} = 5V$, $V_{FB} = 1.3V$)

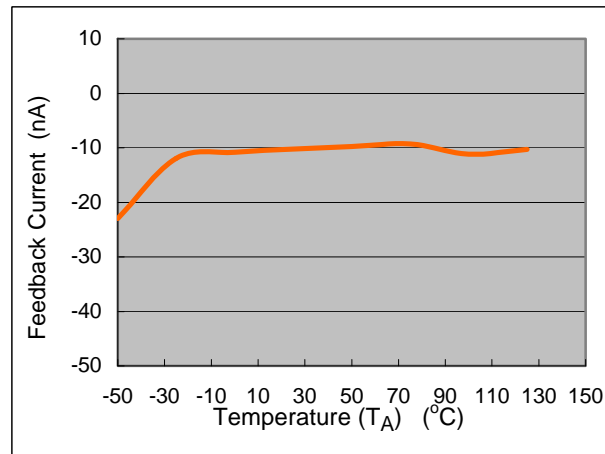



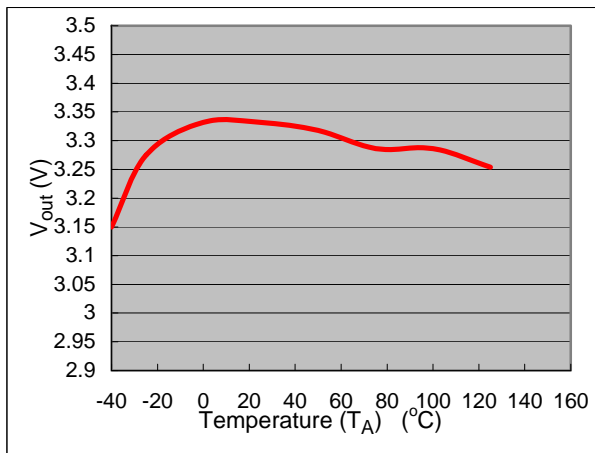

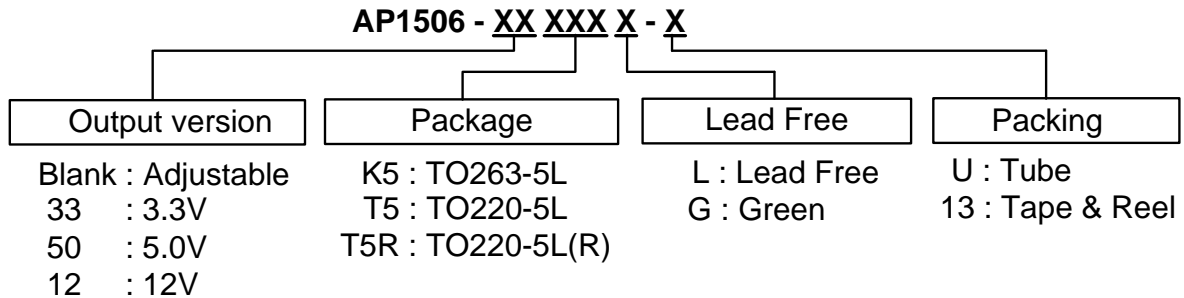

AP1506 Output Voltage vs. Temperature
($V_{IN} = 12V$, $I_o = 3A$)



Ordering Information



Device	Package Code	Packaging (Note 4)	Tube/Bulk		13" Tape and Reel	
			Quantity	Part Number Suffix	Quantity	Part Number Suffix
 AP1506-XXK5L-13	K5	TO263-5L	NA	NA	800/Tape & Reel	-13
 AP1506-XXK5G-13	K5	TO263-5L	NA	NA	800/Tape & Reel	-13
 AP1506-XXT5L-U	T5	TO220-5L	50	-U	NA	NA
 AP1506-XXT5G-U	T5	TO220-5L	50	-U	NA	NA
 AP1506-XXT5RL-U	T5R	TO220-5L(R)	50	-U	NA	NA
 AP1506-XXT5RG-U	T5R	TO220-5L(R)	50	-U	NA	NA

Notes: 4. Pad layout as shown on Diodes Inc. suggested pad layout document AP02001, which can be found on our website at <http://www.diodes.com/datasheets/ap02001.pdf>.

Marking Information

(1) TO263-5L

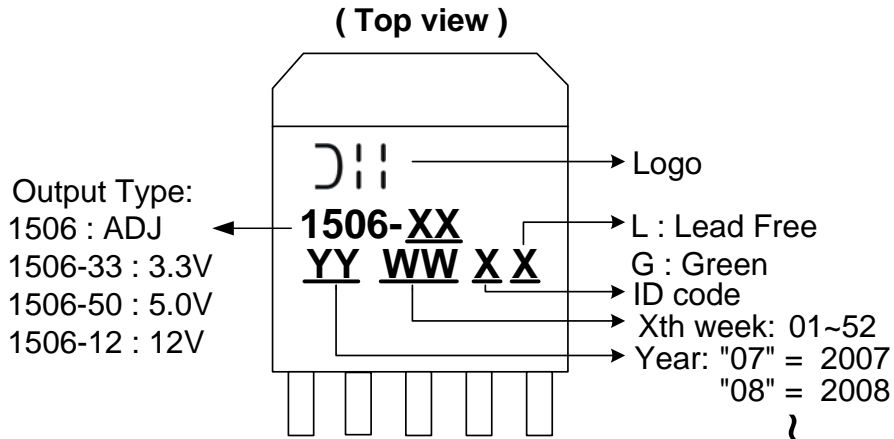

(2) TO220-5L(R)

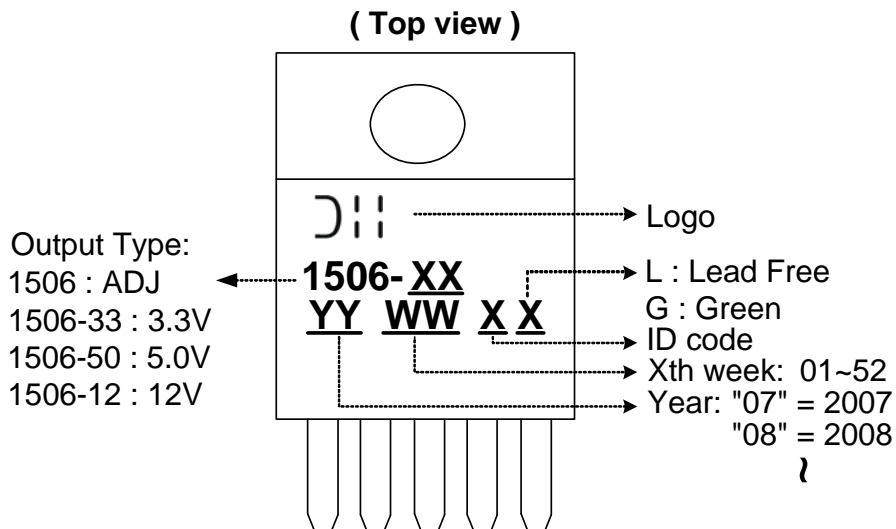

Package Outline Dimensions (All Dimensions in mm)

(1) Package Type: TO263-5L

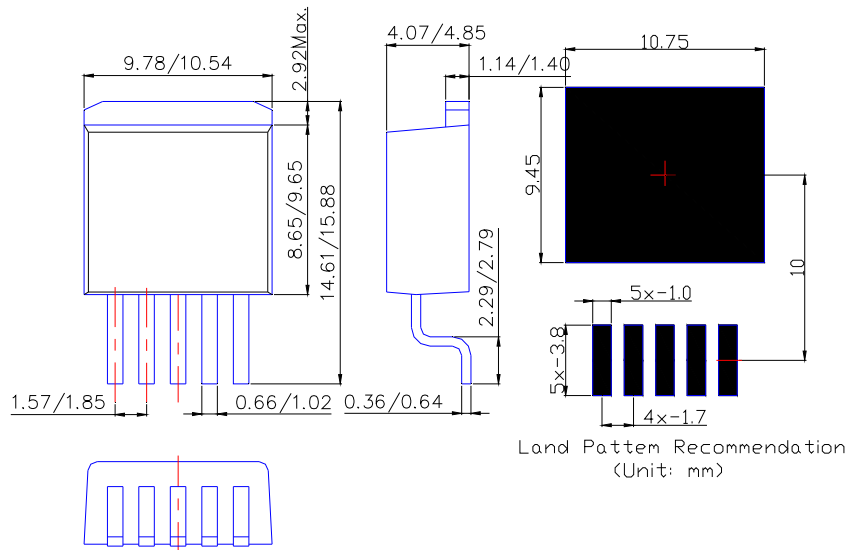

(2) Package Type: TO220-5L

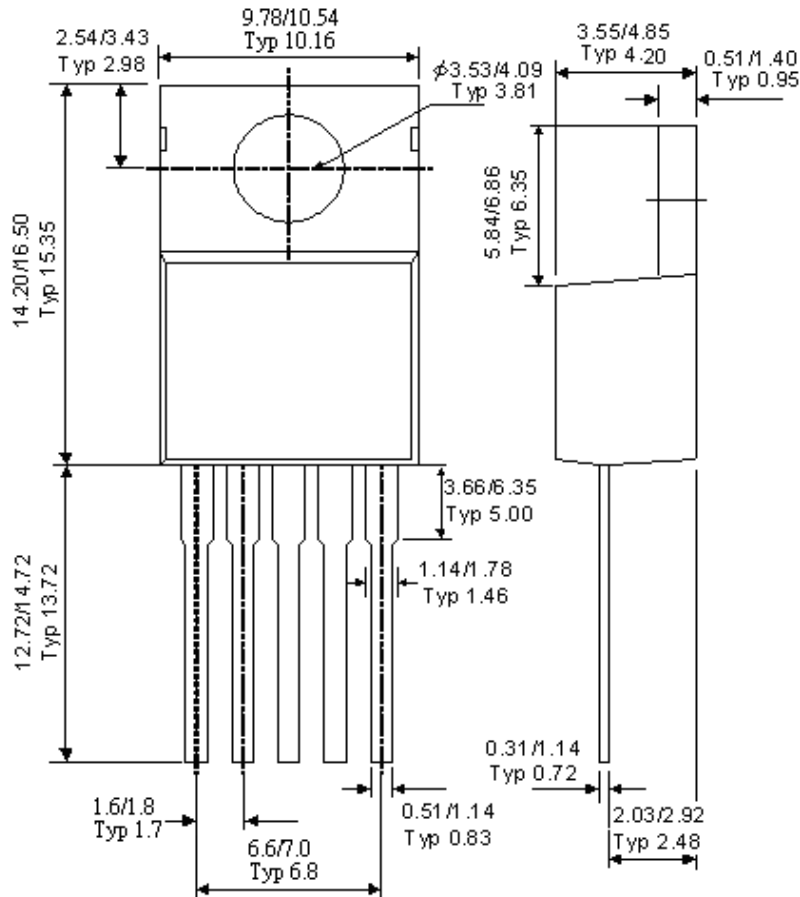

IMPORTANT NOTICE

DIODES INCORPORATED MAKES NO WARRANTY OF ANY KIND, EXPRESS OR IMPLIED, WITH REGARDS TO THIS DOCUMENT, INCLUDING, BUT NOT LIMITED TO, THE IMPLIED WARRANTIES OF MERCHANTABILITY AND FITNESS FOR A PARTICULAR PURPOSE (AND THEIR EQUIVALENTS UNDER THE LAWS OF ANY JURISDICTION).

Diodes Incorporated and its subsidiaries reserve the right to make modifications, enhancements, improvements, corrections or other changes without further notice to this document and any product described herein. Diodes Incorporated does not assume any liability arising out of the application or use of this document or any product described herein; neither does Diodes Incorporated convey any license under its patent or trademark rights, nor the rights of others. Any Customer or user of this document or products described herein in such applications shall assume all risks of such use and will agree to hold Diodes Incorporated and all the companies whose products are represented on Diodes Incorporated website, harmless against all damages.

Diodes Incorporated does not warrant or accept any liability whatsoever in respect of any products purchased through unauthorized sales channel.

Should Customers purchase or use Diodes Incorporated products for any unintended or unauthorized application, Customers shall indemnify and hold Diodes Incorporated and its representatives harmless against all claims, damages, expenses, and attorney fees arising out of, directly or indirectly, any claim of personal injury or death associated with such unintended or unauthorized application.

Products described herein may be covered by one or more United States, international or foreign patents pending. Product names and markings noted herein may also be covered by one or more United States, international or foreign trademarks.

LIFE SUPPORT

Diodes Incorporated products are specifically not authorized for use as critical components in life support devices or systems without the express written approval of the Chief Executive Officer of Diodes Incorporated. As used herein:

A. Life support devices or systems are devices or systems which:

1. are intended to implant into the body, or
2. support or sustain life and whose failure to perform when properly used in accordance with instructions for use provided in the labeling can be reasonably expected to result in significant injury to the user.

B. A critical component is any component in a life support device or system whose failure to perform can be reasonably expected to cause the failure of the life support device or to affect its safety or effectiveness.

Customers represent that they have all necessary expertise in the safety and regulatory ramifications of their life support devices or systems, and acknowledge and agree that they are solely responsible for all legal, regulatory and safety-related requirements concerning their products and any use of Diodes Incorporated products in such safety-critical, life support devices or systems, notwithstanding any devices- or systems-related information or support that may be provided by Diodes Incorporated. Further, Customers must fully indemnify Diodes Incorporated and its representatives against any damages arising out of the use of Diodes Incorporated products in such safety-critical, life support devices or systems.

Copyright © 2010, Diodes Incorporated

www.diodes.com



LittleDiode supplies new, hard to find or obsolete electronic components and semiconductors all over the world.

With over two million different components listed you are sure to find the part you need.

Feel free to visit us today at our online store:

LittleDiode.com

Looking forward to providing you with the best possible service.