



■ General Description

The AME8510/8520/8530 family allows the user to customize the CPU monitoring function without any external components. The user has a large choice of reset voltage thresholds and output driver configurations, all of which are preset at the factory. Each wafer is trimmed to the customer's specifications.

These circuits will ignore fast negative going transients on V_{DD} . The state of the reset output is guaranteed to be correct down to 1V.

After V_{DD} crosses above a factory preset threshold, the AME8510/8520/8530 assert a reset signal. After a predetermined time (the "reset" interval) the reset is deasserted. If V_{DD} ever drops below the threshold voltage a reset is asserted immediately. In addition to a supply monitoring function the AME8510/8520 also monitor transitions at the watch dog (WDI) input. If a logic transition does not occur at the WDI pin within a certain time interval (the "watchdog" interval) then a reset is asserted. The reset deasserts after the reset interval, as explained earlier.

The AME8510/8530 can both assert a reset manually by pulling the MRB input to ground.

Space saving SOT-25 packages and micropower quiescent current make this family a natural for portable battery powered equipment.

■ Features

- Small packages: SOT-25
- 7 voltage threshold options
- Tight voltage threshold tolerance --- $\pm 1.50\%$
- 12 output driver configuration options
- Wide temperature range ----- -40°C to 85°C
- Low temperature coefficient --- $100\text{ppm}/^{\circ}(\text{max})$
- Low quiescent current $< 3.0\mu\text{A}$
- 3 bonding options

■ Applications

- Motherboards
- Computer peripherals
- Portable electronics
- Applications using CPUs
- Consumer electronics

■ Pin Configuration

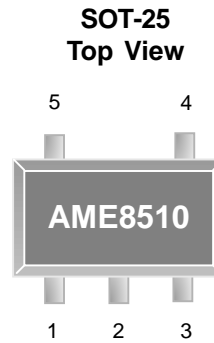

- AME8510**
1. Reset/ResetB
 2. GND
 3. MRB
 4. WDI
 5. V_{DD}

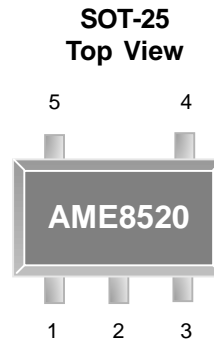

- AME8520**
1. Reset/ResetB
 2. GND
 3. ResetB/Reset
 4. WDI
 5. V_{DD}

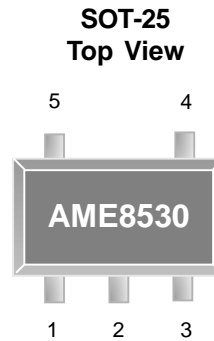

- AME8530**
1. Reset/ResetB
 2. GND
 3. ResetB/Reset
 4. MRB
 5. V_{DD}



■ Pin Description

Pin #			Pin Name	Pin Description
AME8510	AME8520	AME8530		
1	1	1	RESET/ RESETB	This pin may be either RESET or RESETB. RESETB is active low. In the case of the AME8520 and AME8530 this pin will always be the opposite polarity from pin 3. This pin can be push/pull or open drain.
2	2	2	GND	Ground
N/A	3	3	RESET/ RESETB	This pin may be either RESETB or RESET. RESET is active high. In the case of the AME8520 and AME8530 this pin will always be the opposite polarity from pin 1. This pin can be either push/pull or open drain.
3	N/A	4	MRB	Manual Reset. Active low. Pulling this pin low forces a reset. After a low to high transition reset remains asserted for exactly one reset timeout period. This pin is internally pulled high. If this function is unused then float this pin or tie it to V_{DD} .
4	4	N/A	WDI	Watch Dog Input. Any transition on this pin will reset the watch dog timer. If this pin remains high or low for longer than the watch dog interval then a reset is asserted. Float or tristate this pin to disable the watch dog feature.
5	5	5	V_{DD}	Positive power supply. A reset is asserted after this voltage drops below a predetermined level. After V_{DD} rises above that level reset remains asserted until the end of the reset timeout period.



■ Ordering Information

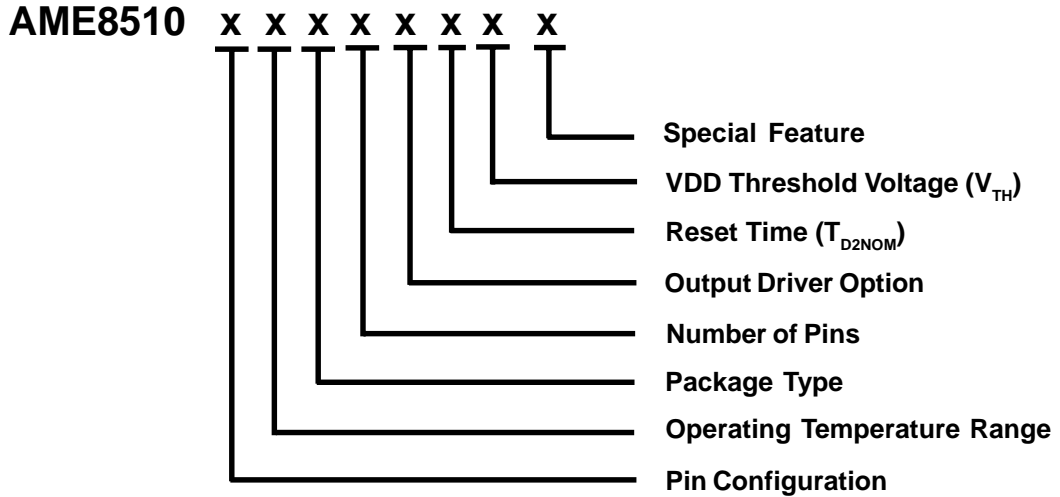

Pin Configuration	Operating Temperature Range	Package Type	Number of Pins	Output Driver Option	Reset Time (T_{D2NOM})	Watch Dog Interval	VDD Threshold Voltage (V_{TH})	Special Feature
A: 1. Reset/ResetB 2. GND 3. MRB 4. WDI 5. VDD	E: -40°C to 85°C	E: SOT-2X	V: 5	PIN1 A: RESETB/PP B: RESETB/OD C: RESET/PP D: RESET/OD E: RESETB/PP F: RESETB/PP G: RESETB/OD H: RESETB/OD I: RESET/PP J: RESET/PP K: RESET/OD L: RESET/OD PIN3 E: RESET/PP F: RESET/OD G: RESET/PP H: RESET/OD I: RESETB/PP J: RESETB/OD K: RESETB/PP L: RESETB/OD (RESET = Active High) (RESETB = Active Low) (PP = Push pull out) (OD = Open drain output polarity)	F: $T_D = 210ms$	E: 1760 ms X: without WDI option	22: $V_{TH} = 2.19V$ 23: $V_{TH} = 2.32V$ 26: $V_{TH} = 2.63V$ 29: $V_{TH} = 2.93V$ 31: $V_{TH} = 3.08V$ 44: $V_{TH} = 4.38V$ 46: $V_{TH} = 4.63V$	L: Low profile Y: Lead free & Low profile Z: Lead free



■ Ordering Information

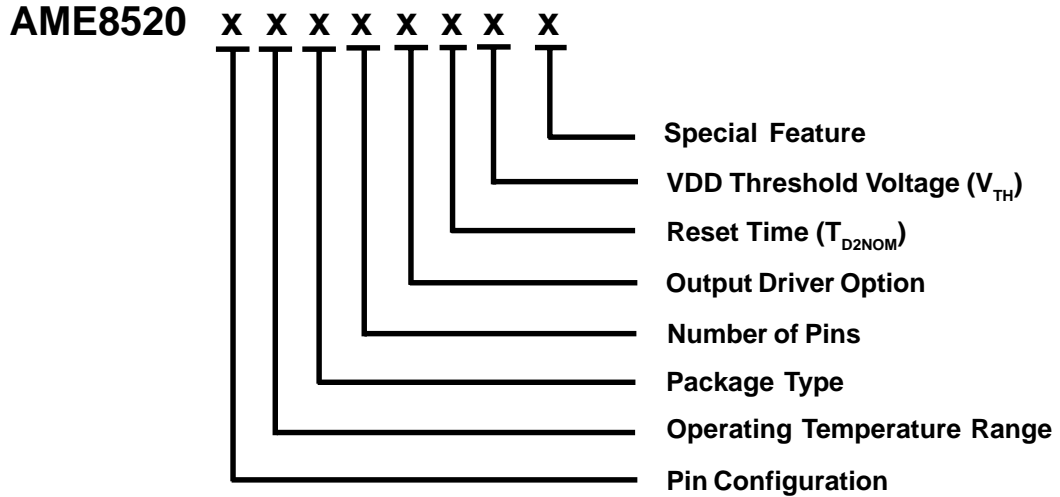

Pin Configuration	Operating Temperature Range	Package Type	Number of Pins	Output Driver Option	Reset Time (T_{D2NOM})	Watch Dog Interval	VDD Threshold Voltage (V_{TH})	Special Feature
A: 1. Reset/ResetB 2. GND 3. Reset/ResetB 4. WDI 5. VDD	E: -40°C to 85°C	E: SOT-2X	V: 5	PIN1 A: RESETB/PP B: RESETB/OD C: RESET/PP D: RESET/OD E: RESETB/PP F: RESETB/PP G: RESETB/OD H: RESETB/OD I: RESET/PP J: RESET/PP K: RESET/OD L: RESET/OD PIN3 E: RESET/PP F: RESET/OD G: RESET/PP H: RESET/OD I: RESETB/PP J: RESETB/OD K: RESETB/PP L: RESETB/OD (RESET = Active High) (RESETB = Active Low) (PP = Push pull out) (OD = Open drain output polarity)	F: $T_D = 210ms$	E: 1760 ms X: without WDI option	22: $V_{TH} = 2.19V$ 23: $V_{TH} = 2.32V$ 26: $V_{TH} = 2.63V$ 29: $V_{TH} = 2.93V$ 31: $V_{TH} = 3.08V$ 44: $V_{TH} = 4.38V$ 46: $V_{TH} = 4.63V$	L: Low profile Y: Lead free & Low profile Z: Lead free



■ Ordering Information

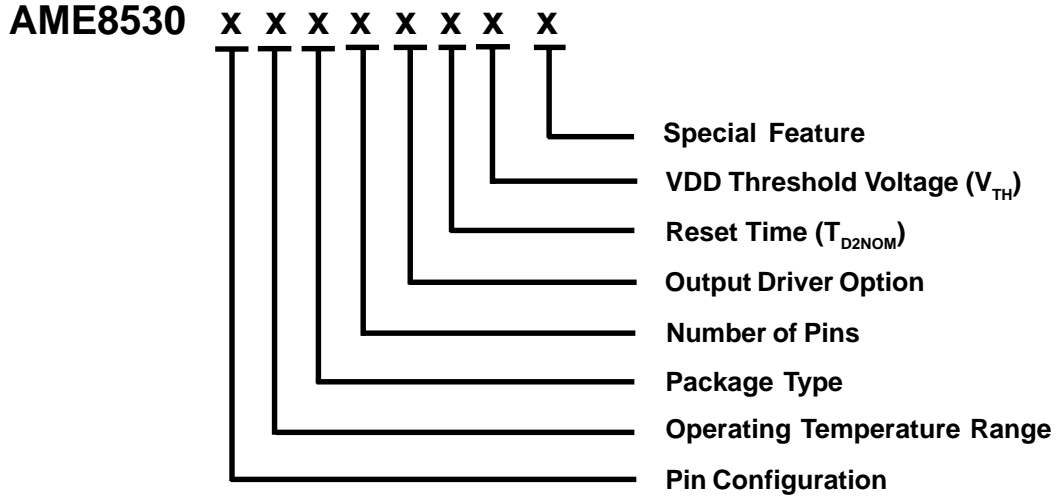

Pin Configuration	Operating Temperature Range	Package Type	Number of Pins	Output Driver Option	Reset Time (T_{D2NOM})	Watch Dog Interval	VDD Threshold Voltage (V_{TH})	Special Feature
A: 1. Reset/ResetB 2. GND 3. Reset/ResetB 4. MRB 5. VDD	E: -40°C to 85°C	E: SOT-2X	V: 5	PIN1 A: RESETB/PP B: RESETB/OD C: RESET/PP D: RESET/OD E: RESETB/PP F: RESETB/PP G: RESETB/OD H: RESETB/OD I: RESET/PP J: RESET/PP K: RESET/OD L: RESET/OD PIN3 E: RESET/PP F: RESET/OD G: RESET/PP H: RESET/OD I: RESETB/PP J: RESETB/OD K: RESETB/PP L: RESETB/OD (RESET = Active High) (RESETB = Active Low) (PP = Push pull out) (OD = Open drain output polarity)	F: $T_D = 210ms$	E: 1760 ms X: without WDI option	22: $V_{TH} = 2.19V$ 23: $V_{TH} = 2.32V$ 26: $V_{TH} = 2.63V$ 29: $V_{TH} = 2.93V$ 31: $V_{TH} = 3.08V$ 44: $V_{TH} = 4.38V$ 46: $V_{TH} = 4.63V$	L: Low profile Y: Lead free & Low profile Z: Lead free

■ Ordering Information

Part Number	Marking	V _{TH} Voltage	Package	Operating Temp. Range
AME8510AEEVAFE26	ATGww	2.63V	SOT-25	- 40°C to + 85°C
AME8510AEEVAFE29	ATXww	2.93V	SOT-25	- 40°C to + 85°C
AME8510AEEVAFE31	ASMww	3.08V	SOT-25	- 40°C to + 85°C
AME8510AEEVBDD29	ARXww	2.93V	SOT-25	- 40°C to + 85°C
AME8510AEEVEFE31	ATUww	3.08V	SOT-25	- 40°C to + 85°C
AME8520AEEVEFE26	ATCww	2.63V	SOT-25	- 40°C to + 85°C
AME8520AEEVEFE29	ATVww	2.93V	SOT-25	- 40°C to + 85°C
AME8520AEEVEFE31	ATLww	3.08V	SOT-25	- 40°C to + 85°C
AME8520AEEVEFE44	ATWww	4.38V	SOT-25	- 40°C to + 85°C
AME8530AEEVAFX29	AVEww	2.93V	SOT-25	- 40°C to + 85°C
AME8530AEEVAFX31	AVFww	3.08V	SOT-25	- 40°C to + 85°C
AME8530AEEVEFX29	AUSww	2.93V	SOT-25	- 40°C to + 85°C
AME8530AEEVEFX29Z	AUSww	2.93V	SOT-25	- 40°C to + 85°C
AME8530AEEVEFX31	ATNww	3.08V	SOT-25	- 40°C to + 85°C

Please consult AME sales office or authorized Rep./Distributor for other RESET TIME interval and Watch Dog time interval.



■ Absolute Maximum Ratings

Parameter	Maximum	Unit
Supply Voltage	6	V
ESD Classification	B	

Caution: Stress above the listed absolute maximum rating may cause permanent damage to the device

■ Recommended Operating Conditions

Parameter	Rating	Unit
Supply Voltage	0.9 - 5	V
Ambient Temperature Range	- 40 to + 85	°C
Junction Temperature	- 40 to + 125	°C

■ Thermal Information

Parameter	Maximum	Unit
Thermal Resistance (SOT-25)	256	°C / W
Maximum Junction Temperature	150	°C
Maximum Lead Temperature (10 Sec)	300	°C

■ Electrical Specifications

TA = 25°C unless otherwise noted

Parameter	Symbol	Test Condition		Min	Typ	Max	Units
V _{DD} Range	V _{RANGE}			1		5.5	V
Supply Current	I _{DD}	WDI and MRB unconnected			3	10.0	μ A
Reset Threshold*	V _{TH}			V _{TH} -1.5%		V _{TH} +1.5%	V
ResetB Output Voltage Hgh	V _{OH}	V _{DD} >V _{TH} max	I _{SOURCE} =0.5mA, TA= -40~85°C	0.8V _{DD}			V
Reset Output Voltage Hgh		V _{DD} <V _{TH} min					
ResetB Output Voltage Low	V _{OL}	V _{DD} <V _{TH} min	I _{SNK} =1.2mA, TA= -40~85°C			0.5	V
Reset Output Voltage Low		V _{DD} >V _{TH} max					
V _{DD} to Reset Delay	T _{D1}	V _{DD} = V _{TH} - 100mV			40		μ S
Reset Timeout Period*	T _{D2}	TA= -40~85°C	Version F	140	210	280	mS
Watch Dog Timeout Period*	T _{WD}	Version E		1120	1760	2400	mS
WDI Pulse Width	T _{WDI}			50			nS
WDI Input Threshold	WDI _{IL}	V _{DD} = V _{TH} x 1.2				0.7	V
	WDI _{IH}			0.8 V _{DD}			V
WDI Input Current	I _{IL}	WDI = 0V		-15	-8		μ A
	I _{IH}	WDI = V _{DD} = 5.0V			8	15	
MRB Input Threshold	MRB _{IL}	V _{DD} = V _{TH} x 1.2				0.7	V
	MRB _{IH}			0.8 V _{DD}			
MRB Pulse Width	T _{WMRB}			1			μ S
MRB Noise Immunity (pulse width with no reset)					100		nS
MRB to Reset Delay	T _{DMRB}				500		nS
MRB Pull Up Resistance				80		120	K ohm

* See the chart on page 3 for available values of this parameter.



■ Detailed Description

The AME8510/8520/8530 are designed to interface with the reset input of a microprocessor and to prevent CPU execution errors due to power up, power down, and other power supply errors. The AME8510/8520 also monitor the CPU health by checking for signal transitions from the CPU at the WDI input.

Reset Output

Each output pin in the family can be configured to be either push/pull or open drain. In addition each output may be either active high or active low with the condition that parts with two outputs must have opposite polarities. Active high reset outputs are denoted as RESET. Active low reset outputs are denoted as RESETB. The selection guide on page 3 of this data sheet shows all possible combinations of output driver configuration.

A reset will be asserted if any of three things happen:

- 1) V_{DD} drops below the threshold (V_{TH})
- 2) The MRB pin is pulled low.
- 3) The WDI pin does not detect a transition within the watch dog interval (T_{WD}).

The reset will remain asserted for the prescribed reset interval after:

- 1) V_{DD} rises above the threshold (V_{TH})
- 2) MRB goes high
- 3) The watch dog timer has timed out causing the reset to assert.

Manual Reset Input

The AME8510 and AME8530 feature a manual reset feature (MRB). A logic low on the MRB pin asserts a reset. The reset remains asserted as long as the MRB pin remains low. After the MRB pin transitions to a high state the reset remains asserted for the prescribed reset interval (T_{D2}). The MRB pin is internally pulled up to V_{DD} by a 100K Ω resistor. It is internally debounced to reject switching transients.

The MRB pin is ESD protected by diodes connected to V_{DD} and GND. So the MRB pin should never be driven higher than V_{DD} or lower than GND.

Watchdog Input

The AME8510 and AME8520 are equipped with a watchdog input (WDI). If the microprocessor does not produce a valid logic edge at the the watchdog input (WDI) within the prescribed watchdog interval (T_{WD}) then a reset asserts. The reset remains asserted for the required reset interval (T_{D2}) At the end of the reset interval the reset is deasserted and the watchdog interval timer starts again from zero.

If the watchdog input is left unconnected or is connected to a tri-stated buffer the watchdog function is disabled. As soon as the WDI input is driven either low or high the watchdog function resumes with the watchdog timer set to zero.

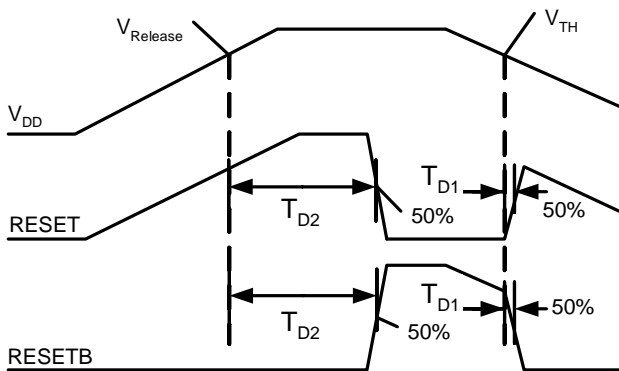

Reset Timing Diagram

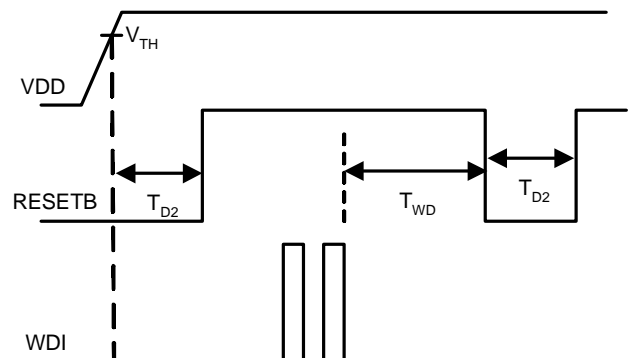

Watchdog Timing Diagram



■ Detailed Description(contd.)

Watchdog Input Current

The watchdog input pin (WDI) typically sources/sinks $8\mu\text{A}$ when driven high or low. So from a power dissipation point of view the duty cycle of the waveform at WDI is unimportant. When the WDI pin is floating or tri-stated the power supply current falls to less than $3.0\mu\text{A}$.

Glitch Rejection

The AME8510/8520/8530 family will reject negative going transients on the V_{DD} line to some extent. The smaller the duration of the transient the larger its amplitude may be without triggering a reset. The “Glitch Rejection” chart in the graphs section of this datasheet shows the relation between glitch amplitude and allowable glitch duration to avoid unintended resets.

Accurate Output State at Low V_{DD}

With V_{DD} voltage on the order of the MOS transistor threshold ($<1.0\text{V}$) the outputs of the AME8510/8520/8530 may become undefined. For parts with active low output (RESETB) a resistor placed between RESETB and GND on the order of $100\text{K}\Omega$ will ensure that the RESETB output stays low when V_{DD} is lower than the threshold voltage of the part. In a like manner a resistor on the order of $100\text{K}\Omega$ when placed between RESET and V_{DD} will ensure parts with active high output (RESET) will remain high when V_{DD} is lower than the threshold voltage of the part.



Glitch Rejection

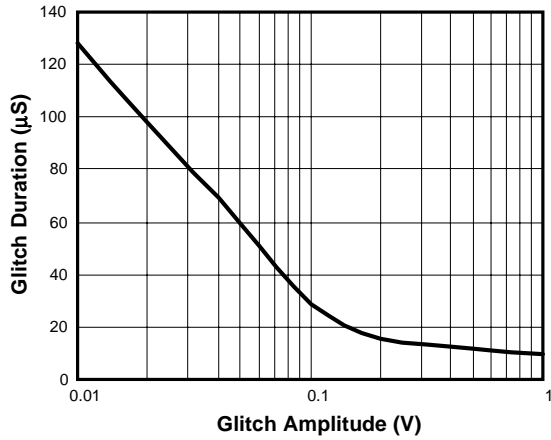

Reset Time vs. Temperature

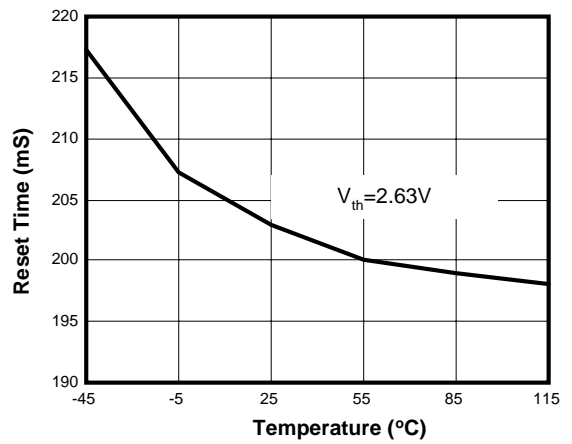

I_{DD} vs. Temperature

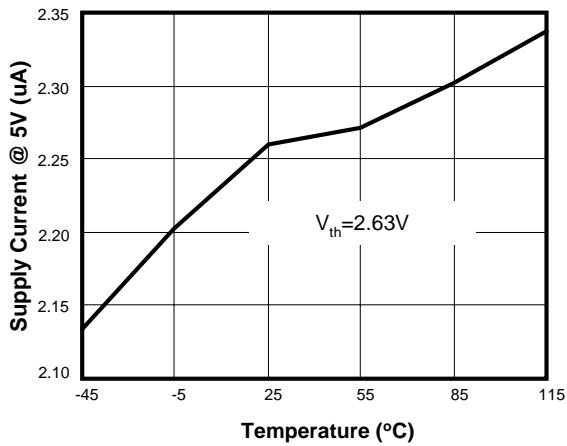

Reset V_{TH} vs. Temperature

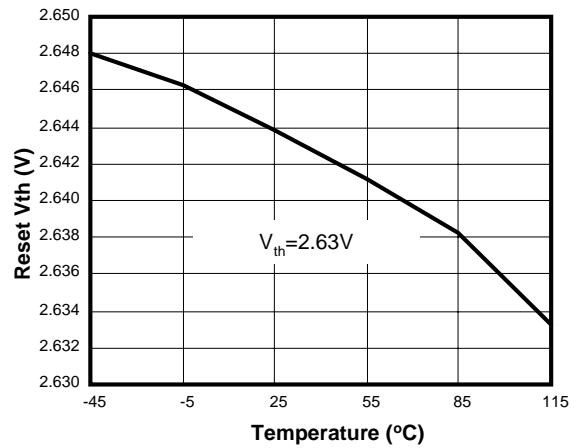

Reset VOL vs. Temperature

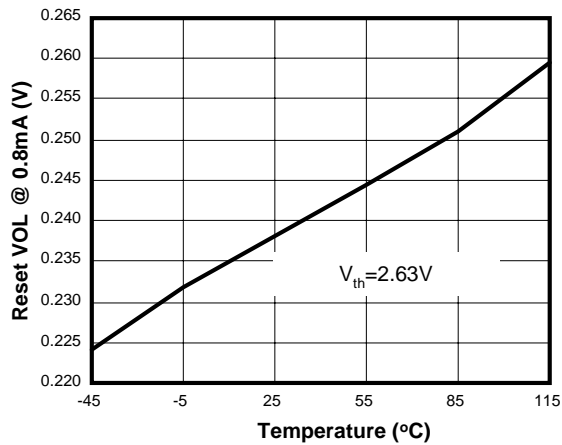



■ Package Dimension

SOT-25

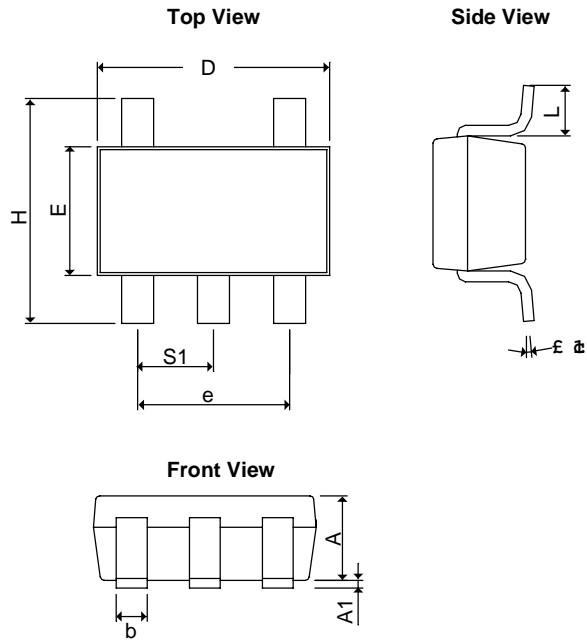

SYMBOLS	MILLIMETERS		INCHES	
	MIN	MAX	MIN	MAX
A	1.20REF		0.0472REF	
A ₁	0.00	0.15	0.0000	0.0059
b	0.30	0.55	0.0118	0.0217
D	2.70	3.10	0.1063	0.1220
E	1.40	1.80	0.0551	0.0709
e	1.90 BSC		0.07480 BSC	
H	2.60	3.00	0.10236	0.11811
L	0.37BSC		0.0146BSC	
θ ₁	0°	10°	0°	10°
S ₁	0.95BSC		0.0374BSC	



www.ame.com.tw
E-Mail: sales@ame.com.tw

Life Support Policy:

These products of AME, Inc. are not authorized for use as critical components in life-support devices or systems, without the express written approval of the president of AME, Inc.

AME, Inc. reserves the right to make changes in the circuitry and specifications of its devices and advises its customers to obtain the latest version of relevant information.

© AME, Inc. , June 2003

Document: 2007-DS8510/8520/8530-C

Corporate Headquarter
AME, Inc.

2F, 189 Kang-Chien Road, Nei-Hu Dist.
Taipei 114 Taiwan, R.O.C.
Tel: 886 2 2627-8687
Fax: 886 2 2659-2989

U.S.A. Subsidiary
Analog Microelectronics, Inc.

3100 De La Cruz Blvd. Suite 201
Santa Clara, CA. 95054-2046
Tel : (408) 988-2388
Fax: (408) 988-2489



LittleDiode supplies new, hard to find or obsolete electronic components and semiconductors all over the world.

With over two million different components listed you are sure to find the part you need.

Feel free to visit us today at our online store:

LittleDiode.com

Looking forward to providing you with the best possible service.