Integrated CMOS Image Sensor with Digital Output and Timing Controller (352 x 288 Resolution)

Technical Data

HDCS-1000 (Color)
HDCS-1100 (Monochrome)

Description

A CMOS active pixel sensor (APS) array, available in both color and monochrome, containing an array of 352 x 288 pixels. This product offers excellent image quality with low power consumption, low dark current, high sensitivity and anti-blooming characteristics. High temperature tolerant color filter array enables machine solderability. Operating from a single bias voltage, this sensor simplifies overall system design.

Features

- CIF (352 x 288 pixels) array size in two options. Color or monochrome versions available
- Random access and windowing capability to zoom to any sized window on 4 x 4 pixel boundaries
- Panning capability to any location within the sensor array
- Video rates up to 45 frames per second for CIF window size
- 4:1 sub-sampling capability of viewing window, providing up to 162 frames per second
- Still image capability
- Mechanical shutter and flash trigger
- Accumulation mode to aid in determining proper exposure time
- Low power/standby modes
- Machine solderable, high temperature tolerant color filter array
- Two 10-bit internal successive-approximation ADCs
- Automatic subtraction of column fixed pattern noise
- Color array using RGB Bayer filter pattern
- Integrated timing controller simplifying system design
- Digital output via 10-bit synchronous parallel interface
- Programmable features include: window size, integration time, gain control (separate for red, green and blue), data rate, interface timing, interrupt control, operation modes, selection of 8 or 10 bit output, drive level of output pads, access to status signals via a synchronous serial or asynchronous UART interface



Typical Applications

- Video conferencing camera
- Digital still camera
- Surveillance and security video camera
- Automotive
- Machine vision system
- Biometric security system (e.g., fingerprint recognition)
- Toys

Typical Electrical Specifications

Pixel Size	7.8 x 7.8 μm
Maximum Clock Rate	25 MHz from externally supplied clock source
A/D Dynamic Range	60 dB
Pixel Signal-to-Noise Ratio (SNR)	66 dB
Noise (Equivalent electrons) kTC	36 electrons
Dark Current ^[1]	0.1 nA/cm ² @ 22°C ambient
Sensitivity ^[2]	1.3 V/(Lux-sec @ 550 nm)
Peak Quantum Efficiency ^[1, 2]	21%
Saturation	1.3 V
Full Well Capacity	65,000 electrons
Conversion Gain ^[2]	16 $\mu\text{V}/\text{electron}$
Programmable Gain Range	1 – 40 (255 increments)
Fill Factor	42%
Exposure Control	0.5 μs – 4 s in 0.5 μs steps
Package	44 pin gull wing optical PQFP
Supply Voltage	3.3 V, -5/+10%
Power Consumption	200 mW max operating; 3.3 mW max standby
Operating Temperature	-5 to 65°C

Notes:

1. Specified over complete pixel
2. Measured at unity gain

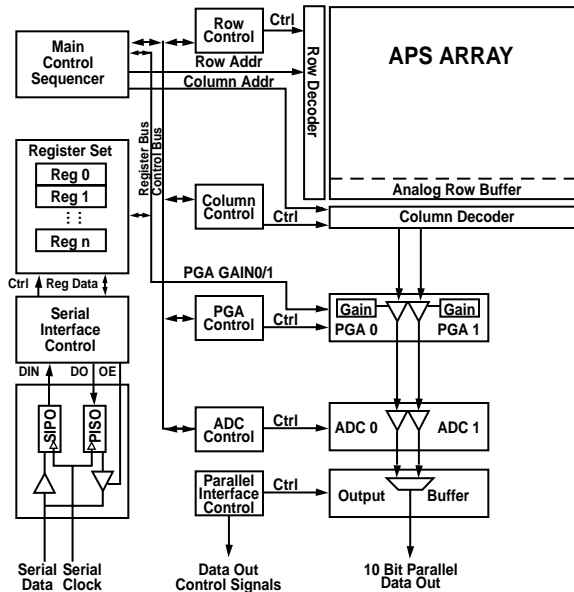

Block Diagram—Sensor Architecture

www.hp.com/go/imagingelectronics

For technical assistance or the location of your nearest Hewlett-Packard sales office, distributor or representative call:

Americas/Canada: 1-800-235-0312 or 408-654-8675

Far East/Australasia: Call your local HP sales office.

Japan: (81 3) 3335-8152

Europe: Call your local HP sales office.

Data subject to change.
Copyright © 1998 Hewlett-Packard Co.
Obsoletes 5968-2422E

This datasheet has been downloaded from:

www.DatasheetCatalog.com

Datasheets for electronic components.



LittleDiode supplies new, hard to find or obsolete electronic components and semiconductors all over the world.

With over two million different components listed you are sure to find the part you need.

Feel free to visit us today at our online store:

LittleDiode.com

Looking forward to providing you with the best possible service.