

Silicon Bipolar MMIC-Amplifier

- Cascadable 50 Ω-gain block
- 9 dB typical gain at 1.0 GHz
- 9 dBm typical P_{-1dB} at 1.0 GHz
- 3 dB-bandwidth: DC to 2.4 GHz

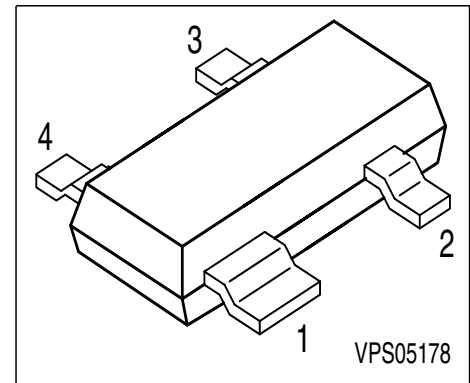

Circuit Diagram

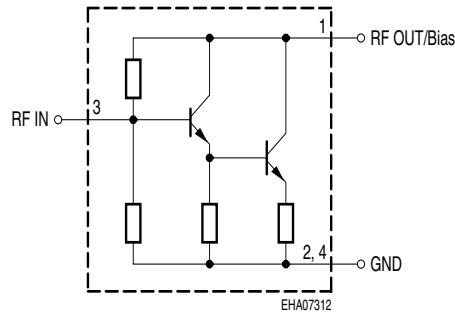

Type	Marking	Pin Configuration				Package
BGA 310	BLs	1 RFout/bias	2 GND	3 RF input	4 GND	SOT-143

Maximum Ratings

Parameter	Symbol	Value	Unit
Device current	I_D	60	mA
Total power dissipation, $T_S \leq 99\text{ °C}^1)$	P_{tot}	250	mW
RF input power	P_{RFIn}	10	dBm
Junction temperature	T_j	150	°C
Ambient temperature	T_A	-65 ... 150	
Storage temperature	T_{stg}	-65 ... 150	

Thermal Resistance

Junction - soldering point	R_{thJS}	≤ 205	K/W
----------------------------	------------	-------	-----

¹ T_S is measured on the collector lead at the soldering point to the pcb

Electrical Characteristics at $T_A = 25\text{ }^\circ\text{C}$, unless otherwise specified.

Parameter	Symbol	Values			Unit
		min.	typ.	max.	
AC characteristics ($V_D = 4.7\text{ V}$, $Z_0 = 50\ \Omega$)					
Insertion power gain $f = 0.1\text{ GHz}$ $f = 1\text{ GHz}$ $f = 1.8\text{ GHz}$	$ S_{21} ^2$	-	10 9 8	-	dB
Insertion point gain flatness $f = 0.1\text{ GHz to }0.6\text{ GHz}$	$\Delta S_{21} ^2$	-	+0.5	-	dB
Noise figure $f = 0.1\text{ GHz}$ $f = 1\text{ GHz}$ $f = 2\text{ GHz}$	NF	-	6 6.5 7	-	dB
1dB compression point $f = 1\text{ GHz}$	P_{-1dB}	-	9	-	dBm
Return loss input $f = 0.1\text{ GHz to }2\text{ GHz}$	RL_{in}	-	20	-	dB
Return loss output $f = 0.1\text{ GHz to }3\text{ GHz}$	RL_{out}	-	15	-	

Typical biasing configuration

$$R_{Bias} = V_{CC} - V_D / I_D$$

$$V_D = 4.7V$$

S-Parameters at $T_A = 25\text{ °C}$

f GHz	S_{11}		S_{21}		S_{12}		S_{22}	
	MAG	ANG	MAG	ANG	MAG	ANG	MAG	ANG
$V_D = 4.7\text{ V}, Z_0 = 50\Omega$								
0.01	0.051	176.4	3.22	179.3	0.149	0.2	0.159	-0.5
0.1	0.053	168.1	3.23	174.9	0.149	1.2	0.158	-6.1
0.3	0.053	141.9	3.22	164.6	0.15	3.4	0.157	-19
0.5	0.058	123.9	3.2	154.2	0.152	5.4	0.155	-31.7
0.8	0.054	98.2	3.17	138.7	0.157	8.1	0.153	-51.3
1	0.049	86.1	3.12	128.4	0.162	9.7	0.153	-64.3
1.8	0.053	-164.9	2.79	88	0.188	12	0.16	-106.6
2.4	0.161	-177.7	2.41	60.8	0.208	10.6	0.168	-123.7
3	0.257	153.9	2.03	38.2	0.225	8.2	0.178	-133.1

Insertion power gain $|S_{21}|^2 = f(f)$

Noise figure $NF = f(f)$

$V_D = 4.7\text{ V}, I_D = 42\text{ mA}$

$V_D = 4.7\text{ V}, I_D = 42\text{ mA}$

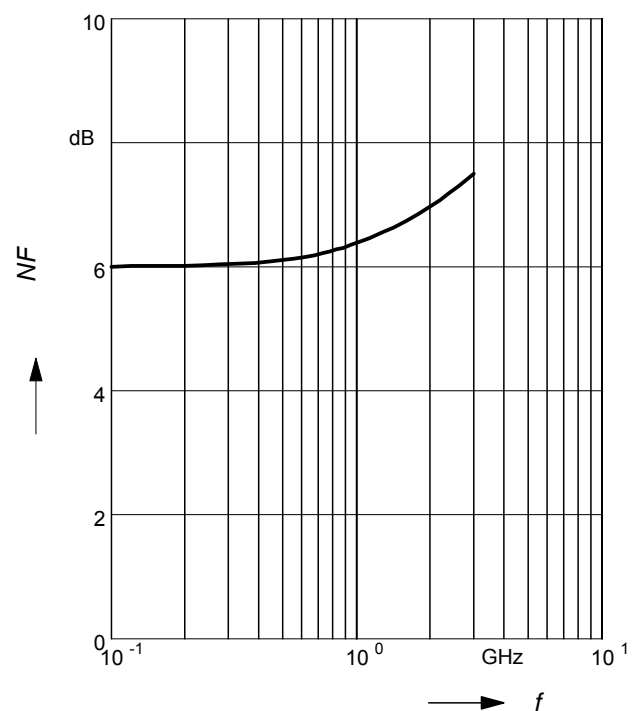
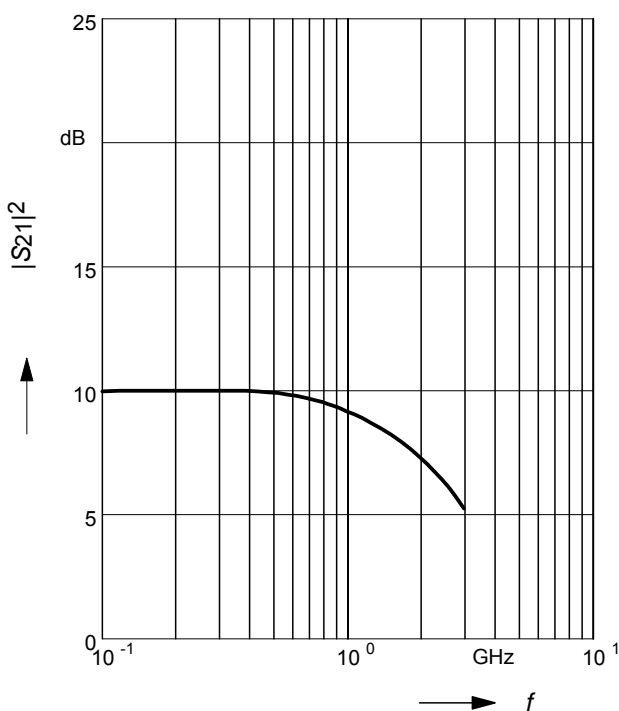

Output power 1-dB-gain compression

$$P_{-1dB} = f(f)$$

$V_D = 4.7 \text{ V}, I_D = 42 \text{ mA}$

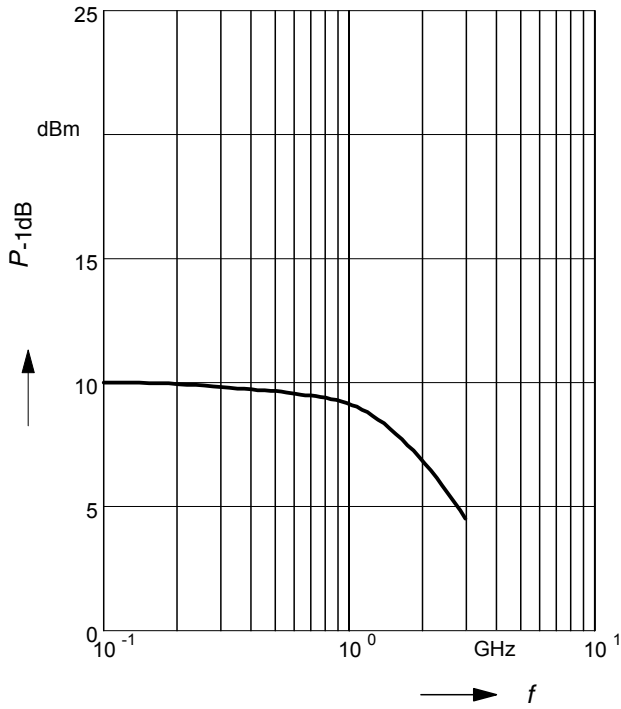



LittleDiode supplies new, hard to find or obsolete electronic components and semiconductors all over the world.

With over two million different components listed you are sure to find the part you need.

Feel free to visit us today at our online store:

LittleDiode.com

Looking forward to providing you with the best possible service.