

■ General Description

The AME8500 family allows the user to customize the CPU reset function without any external components. The user has a large choice of reset voltage thresholds, reset time intervals, and output driver configurations, all of which are preset at the factory. Each wafer is trimmed to the customer's specifications.

These circuits monitor the power supply voltage of μP based systems. When the power supply voltage drops below the voltage threshold a reset is asserted immediately (within an interval T_{D1}). The reset remains asserted after the supply voltage rises above the voltage threshold for a time interval, T_{D2} . The reset output may be either active high (RESET) or active low (RESETB). The reset output may be configured as either push/pull or open drain. The state of the reset output is guaranteed to be correct for supply voltages greater than 1V.

The AME8501 includes all the above functionality plus an overtemperature shutdown function. When the ambient temperature exceeds 80°C a reset is asserted and remains asserted until the temperature falls below 60°C.

Space saving SOT23 packages and micropower quiescent current (<3.0μA) make this family a natural for portable battery powered equipment.

■ Features

- Small packages: SOT-23, SOT-89
- 11 voltage threshold options
- Tight voltage threshold tolerance ---±1.50%
- 5 reset interval options
- 4 output configuration options
- Wide temperature range ----- -40°C to 85°C
- Low temperature coefficient --- 100ppm/°C(max)
- Low quiescent current < 3.0μA
- Thermal shutdown option (AME8501)

■ Applications

- Portable electronics
- Power supplies
- Computer peripherals
- Data acquisition systems
- Applications using CPUs
- Consumer electronics

■ Typical Operating Circuit

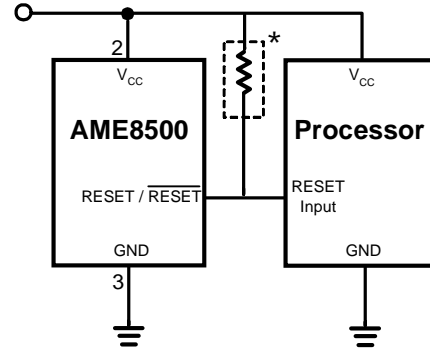

Note: * External pull-up resistor is required if open-drain output is used. 10 kΩ is recommended.

■ Block Diagram

AME8500 with Push-Pull RESET

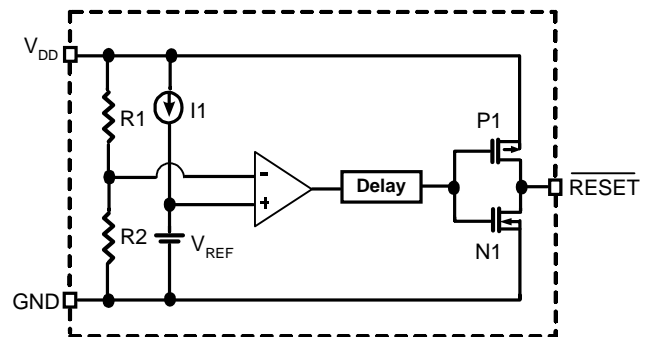

AME8500 with Push-Pull RESET

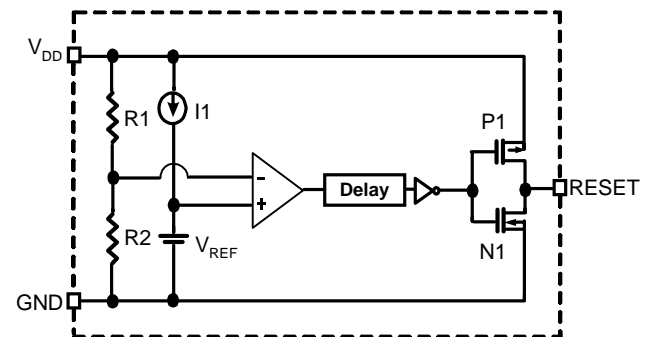

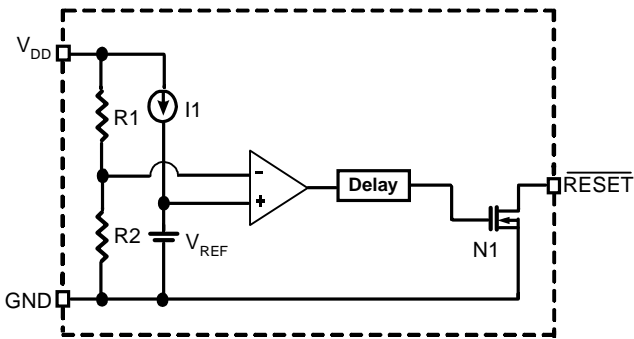
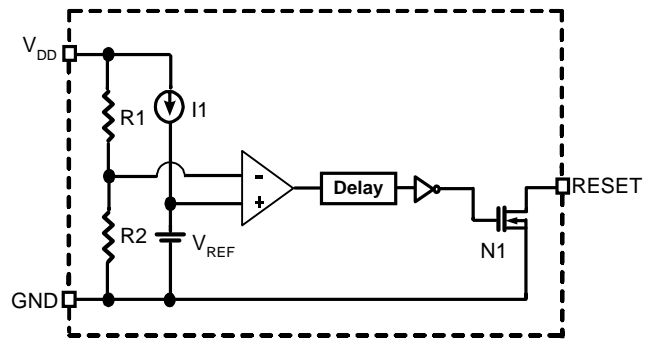
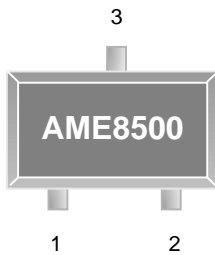
■ Block Diagram (contd.)
AME8500 with Open-Drain $\overline{\text{RESET}}$

AME8500 with Open-Drain RESET

■ Pin Configuration
**SOT-23
Top View**

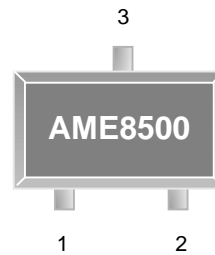
AME8500AEET
AME8501AEET

1. GND
2. Reset/ResetB
3. V_{DD}

**SOT-23
Top View**

AME8500BEET
AME8501BEET

1. Reset/ResetB
2. GND
3. V_{DD}

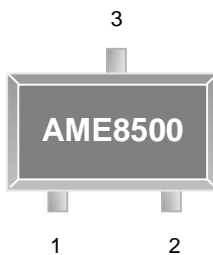
**SOT-23
Top View**

AME8500CEET
AME8501CEET

1. Reset/ResetB
2. V_{DD}
3. GND

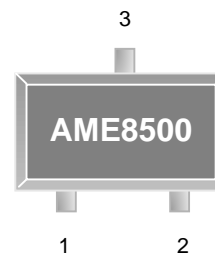
**SOT-23-L
Top View**

AME8500AEET
AME8501AEET

1. GND
2. Reset/ResetB
3. V_{DD}



■ Pin Configuration (contd.)

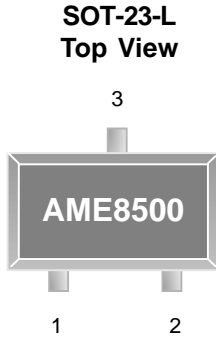

- AME8500BEET**
AME8501BEET
1. Reset/ResetB
 2. GND
 3. V_{DD}

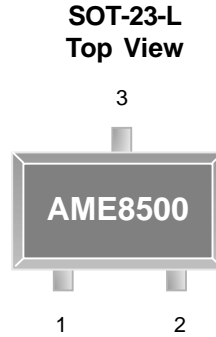

- AME8500CEET**
AME8501CEET
1. Reset/ResetB
 2. V_{DD}
 3. GND



- AME8500AEFT**
AME8501AEFT
1. GND
 2. V_{DD}
 3. Reset/ResetB



- AME8500BEFT**
AME8501BEFT
1. Reset/ResetB
 2. V_{DD}
 3. GND



- AME8500CEFT**
AME8501CEFT
1. V_{DD}
 2. GND
 3. Reset/ResetB

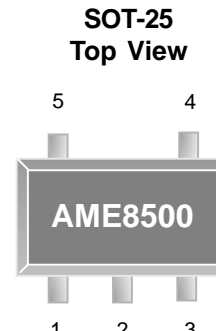

- AME8500BEEV**
AME8501BEEV
1. Reset/ResetB
 2. V_{DD}
 3. GND
 4. N/C
 5. N/C

■ Pin Description

Pin Name	Pin Description
GND	Ground
RESETB/RESET	This pin can be ordered as RESET or RESETB. RESET is active high. RESETB is active low. It is also available with an open drain or pushpull output.
V_{DD}	Positive power supply. A reset is asserted after this voltage drops below a predetermined level. After V_{DD} rises above that level the reset output remains asserted until the end of the reset timeout period.



■ Ordering Information

AME8500 X X X X X X X X
 AME8501 X X X X X X X X

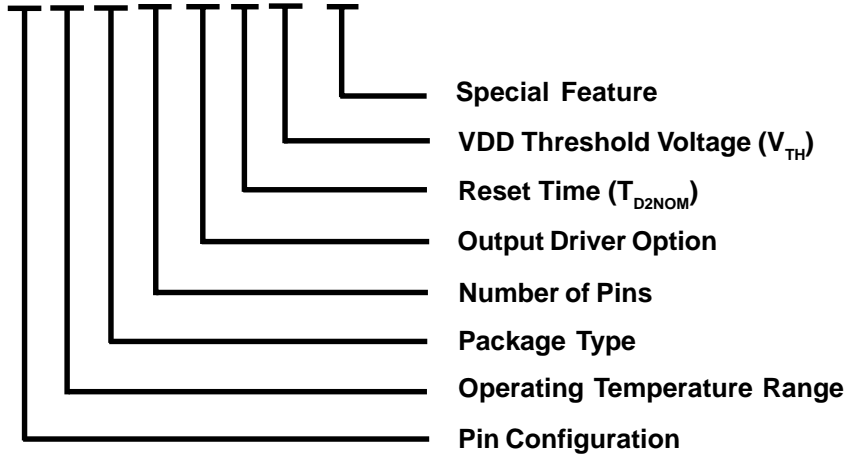

Pin Configuration	Operating Temperature Range	Package Type	Number of Pins	Output Driver Option Characteristic of RESET or RESETB pin	Reset Time (T _{D2NOM})	VDD Threshold Voltage (V _{TH})	Special Feature
A (SOT-23) 1. GND 2. Reset/ResetB 3. VDD B (SOT-23) 1. Reset/ResetB 2. GND 3. VDD C (SOT-23) 1. Reset/ResetB 2. VDD 3. GND A (SOT-89) 1. GND 2. VDD 3. Reset/ResetB B (SOT-89) 1. Reset/ResetB 2. VDD 3. GND C (SOT-89) 1. VDD 2. GND 3. Reset/ResetB	E: -40°C to 85°C	E: SOT-2X F: SOT-89	T: 3 V: 5	A: RESETB /PP B: RESETB /OD C: RESET/ PP D: RESET/ OD (RESET = Active High) (RESETB = Active Low) (PP = Push pull out) (OD = Open drain output polarity)	A: 1.5 ms D: 30 ms E: 150 ms F: 210 ms	15: VTH= 1.5V 16: VTH= 1.6V 18: VTH= 1.8V 19: VTH= 1.9V 20: VTH= 2.0V 21: VTH= 2.1V 22: VTH= 2.2V 23: VTH= 2.32V 24: VTH= 2.4V 26: VTH= 2.63V 27: VTH= 2.7V 28: VTH= 2.8V 29: VTH= 2.93V 31: VTH= 3.08V 40: VTH= 4.0V 42: VTH= 4.2V 44: VTH= 4.38V 46: VTH= 4.63V	L: Low profile Y: Lead free & Low profile Z: Lead free

■ Ordering Information

Part Number	Marking	V _{TH} Voltage	Package	Operating Temp. Range
AME8500AEETAA21	ASVww	2.10V	SOT-23	- 40°C to + 85°C
AME8500AEETAD20	ALXww	2.00V	SOT-23	- 40°C to + 85°C
AME8500AEETAE20	AUAww	2.00V	SOT-23	- 40°C to + 85°C
AME8500AEETAE21	AVGww	2.10V	SOT-23	- 40°C to + 85°C
AME8500AEETAE26	ASJww	2.63V	SOT-23	- 40°C to + 85°C
AME8500AEETAE26L	ASJww	2.63V	SOT-23	- 40°C to + 85°C
AME8500AEETAE29	ALYww	2.93V	SOT-23	- 40°C to + 85°C
AME8500AEETAE31	AUBww	3.08V	SOT-23	- 40°C to + 85°C
AME8500AEETAE46	ATSww	4.63V	SOT-23	- 40°C to + 85°C
AME8500AEETAF15	ATDww	1.50V	SOT-23	- 40°C to + 85°C
AME8500AEETAF16	ATEww	1.60V	SOT-23	- 40°C to + 85°C
AME8500AEETAF21	ASKww	2.10V	SOT-23	- 40°C to + 85°C
AME8500AEETAF23	ATTww	2.32V	SOT-23	- 40°C to + 85°C
AME8500AEETAF26	AMPww	2.63V	SOT-23	- 40°C to + 85°C
AME8500AEETAF27	ATRww	2.70V	SOT-23	- 40°C to + 85°C
AME8500AEETAF29	AMOww	2.93V	SOT-23	- 40°C to + 85°C
AME8500AEETAF31	ASAww	3.08V	SOT-23	- 40°C to + 85°C
AME8500AEETAF40	ASBww	4.00V	SOT-23	- 40°C to + 85°C
AME8500AEETAF44	ARNww	4.38V	SOT-23	- 40°C to + 85°C
AME8500AEETAF46	ARKww	4.63V	SOT-23	- 40°C to + 85°C
AME8500AEETBF31	AUTww	3.08V	SOT-23	- 40°C to + 85°C
AME8500AEETBF46	AUUww	4.63V	SOT-23	- 40°C to + 85°C
AME8500AEETCA21	ASWww	2.10V	SOT-23	- 40°C to + 85°C
AME8500AEETCA27	AVBww	2.70V	SOT-23	- 40°C to + 85°C
AME8500AEETCA46	AVCww	4.63V	SOT-23	- 40°C to + 85°C
AME8500AEETCD20	ALZww	2.00V	SOT-23	- 40°C to + 85°C
AME8500AEETCF21	ATYww	2.10V	SOT-23	- 40°C to + 85°C
AME8500AEETCF29	ALVww	2.93V	SOT-23	- 40°C to + 85°C
AME8500AEETCF31	ASUww	3.08V	SOT-23	- 40°C to + 85°C

■ Ordering Information (contd.)

Part Number	Marking	V_{TH} Voltage	Package	Operating Temp. Range
AME8500AEETCF46	ARJww	4.63V	SOT-23	- 40°C to + 85°C
AME8500AEETDF46	ARlww	4.63V	SOT-23	- 40°C to + 85°C
AME8500AEFTAA21	A8500A AA21ww	2.10V	SOT-89	- 40°C to + 85°C
AME8500AEFTAF27	A8500A AF27ww	2.70V	SOT-89	- 40°C to + 85°C
AME8500AEFTCA21	A8500A CA21ww	2.10V	SOT-89	- 40°C to + 85°C
AME8500AEFTDA21	A8500A DA21ww	2.10V	SOT-89	- 40°C to + 85°C
AME8500BEETAA21	ARTww	2.10V	SOT-23	- 40°C to + 85°C
AME8500BEETAA27	ARMww	2.70V	SOT-23	- 40°C to + 85°C
AME8500BEETAA28	ASRww	2.80V	SOT-23	- 40°C to + 85°C
AME8500BEETAA29	ARZww	2.93V	SOT-23	- 40°C to + 85°C
AME8500BEETAF27	AUCww	2.70V	SOT-23	- 40°C to + 85°C
AME8500BEETAF29	AUVww	2.93V	SOT-23	- 40°C to + 85°C
AME8500BEETAF31	ATOww	3.08V	SOT-23	- 40°C to + 85°C
AME8500BEETAF40	ATQww	4.00V	SOT-23	- 40°C to + 85°C
AME8500BEETBA21	AUWww	2.10V	SOT-23	- 40°C to + 85°C
AME8500BEETBA22	AVDww	2.20V	SOT-23	- 40°C to + 85°C
AME8500BEETBA24	AUXww	2.40V	SOT-23	- 40°C to + 85°C
AME8500BEETBA27	ASQww	2.70V	SOT-23	- 40°C to + 85°C
AME8500BEETBA28	ASSww	2.80V	SOT-23	- 40°C to + 85°C
AME8500BEETBA28L	ASSww	2.80V	SOT-23	- 40°C to + 85°C
AME8500BEETBA28Y	ASSww	2.80V	SOT-23	- 40°C to + 85°C
AME8500BEETBA29	ARLww	2.93V	SOT-23	- 40°C to + 85°C

■ Ordering Information (contd.)

Part Number	Marking	V _{TH} Voltage	Package	Operating Temp. Range
AME8500BEETBA42	ASlww	4.20V	SOT-23	- 40°C to + 85°C
AME8500BEETCA21	ASXww	2.10V	SOT-23	- 40°C to + 85°C
AME8500BEEVAK27	AUFww	2.70V	SOT-25	- 40°C to + 85°C
AME8500BEFTAA21	A8500B AA21ww	2.10V	SOT-89	- 40°C to + 85°C
AME8500BEFTAA27	A8500B AA27ww	2.70V	SOT-89	- 40°C to + 85°C
AME8500BEFTAF27	A8500B AF27ww	2.70V	SOT-89	- 40°C to + 85°C
AME8500BEFTAF40	A8500B AF40ww	4.00V	SOT-89	- 40°C to + 85°C
AME8500BEFTBA23	A8500B BA23ww	2.32V	SOT-89	- 40°C to + 85°C
AME8500CEETAA21	ASYww	2.10V	SOT-23	- 40°C to + 85°C
AME8500CEETAE26	ASHww	2.63V	SOT-23	- 40°C to + 85°C
AME8500CEETAE42	AUZww	4.20V	SOT-23	- 40°C to + 85°C
AME8500CEETAF29	ASLww	2.93V	SOT-23	- 40°C to + 85°C
AME8500CEETBE42	AVAww	4.20V	SOT-23	- 40°C to + 85°C
AME8500CEETBF31	AVYww	3.08V	SOT-23	- 40°C to + 85°C
AME8500CEETBF46	ARWww	4.63V	SOT-23	- 40°C to + 85°C
AME8500CEETCA21	ASZww	2.10V	SOT-23	- 40°C to + 85°C
AME8500CEFTBA27	A8500C BA27ww	2.70V	SOT-89	- 40°C to + 85°C
AME8500CEFTBA29	A8500C BA29ww	2.93V	SOT-89	- 40°C to + 85°C
AME8500CEFTBA42	A8500C BA42ww	4.20V	SOT-89	- 40°C to + 85°C
AME8500CEFTCD28	A8500C CD28ww	2.80V	SOT-89	- 40°C to + 85°C
AME8500CEFTCD46	A8500C CD46ww	4.63V	SOT-89	- 40°C to + 85°C

Please consult AME sales office or authorized Rep./Distributor for other voltage options.



■ Absolute Maximum Ratings

Parameter	Maximum	Unit
Supply Voltage	7	V
ESD Classification	B	
Input Current, V _{DD}	20	mA
Output Current, RESET, ResetB	20	mA
Rate of Rise, V _{DD}	100	V/μs

Caution: Stress above the listed absolute maximum rating may cause permanent damage to the device

■ Recommended Operating Conditions

Parameter	Rating	Unit
Supply Voltage	1.6 - 5	V
Ambient Temperature Range	- 40 to + 85	°C
Junction Temperature	- 40 to + 125	°C
Storage Temperature	- 65 to 150	°C

■ Thermal Information

Parameter		Maximum	Unit
Thermal Resistance	SOT-23	325	°C / W
	SOT-89	180	
Power Dissipation	SOT-23	350	mW
	SOT-89	650	
Maximum Junction Temperature		150	°C
Maximum Lead Temperature (10 Sec)		300	°C

■ Electrical Specifications

TA = 25°C unless otherwise noted

Parameter	Symbol	Test Condition		Min	Typ	Max	Units
V _{DD} Range*	V _{RANGE}			1		5.5	V
		TA=-40~85°C		1		5.5	
Supply Current	I _{DD}	V _{DD} = V _{TH} *1.10				3.0	μA
		V _{DD} = V _{TH} *1.10, TA=-40~85°C				5.0	
Reset Threshold	V _{TH}			V _{THNOM} -1.5%		V _{THNOM} +1.5%	mV
		TA=-40~85°C		V _{THNOM} -2.0%		V _{THNOM} +2.0%	
Hysteresis Range	V _{HYST}	V _{RELEASE} - V _{TH} , note1			20		mV
RESET Threshold Tempco					30		ppm
RESETB Output Voltage Low	V _{OL}	V _{DD} <V _{TH} (MIN)	I _{SINK} =1.2mA, TA= -40~85°C			0.5	V
RESET Output Voltage Low		V _{DD} >V _{TH} (MAX)					
RESETB Output Voltage High	V _{OH}	V _{DD} >V _{TH} (MAX)	I _{SOURCE} =0.5mA, V _{DD} >1.8V	0.8V _{DD}			V
RESET Output Voltage High			V _{DD} <V _{TH} (MIN)				
	I _{SOURCE} =0.5mA, V _{DD} >1.8V						
		I _{SOURCE} =0.15mA, 1.8V>=V _{DD} >1.0V					
V _{DD} to Reset Delay	T _{D1}	V _{DD} = V _{TH} - 100mV, TA= -40 ~ 85°C			40	200	μS
Reset Timeout Period*	T _{D2}	TA= -40 ~ 85°C	Version A	0.5	1.5	5	mS
			Version D	15	30	50	mS
			Version E	80	150	230	mS
			Version F	140	210	500	mS
			Version K	300	440	600	mS
Temperature Shutdown	T _{OFF}	AME8501 only			80		°C
Temperature Shutdown Hysteresis	T _{HYS}	AME8501 only			20		°C

Note1: The data based on V_{TH}=2.7V part type.

■ Timing Diagram

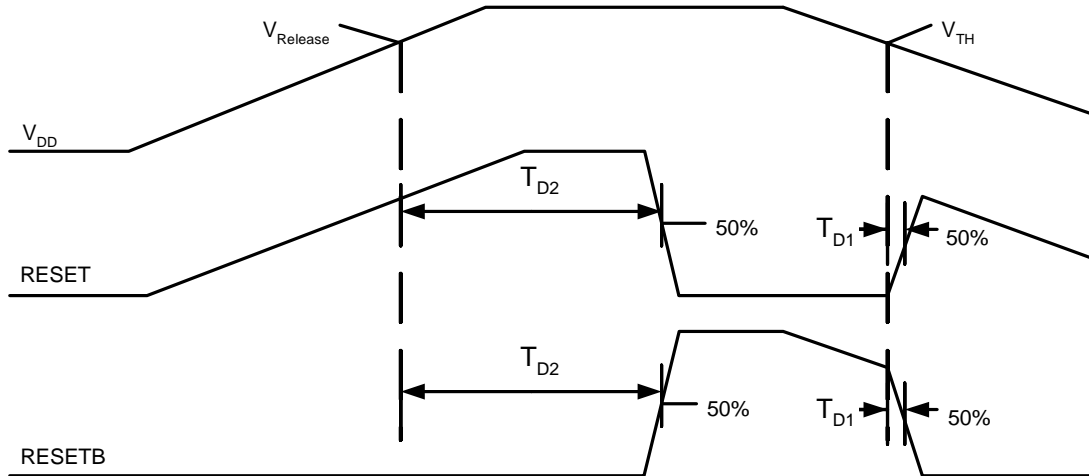

■ Applications Information

Supply Transients

These devices have a certain immunity to fast negative going transients. In the following pages the graph titled "Glitch Rejection" indicates the maximum allowable glitch amplitude and duration to avoid triggering an unintended reset. As shown in the graph shorter transients can have larger amplitudes without triggering resets.

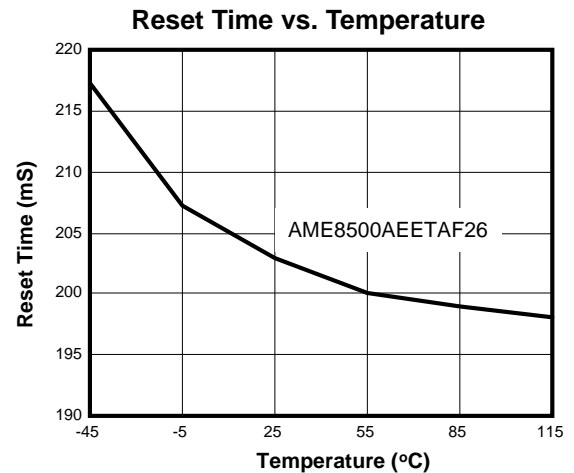
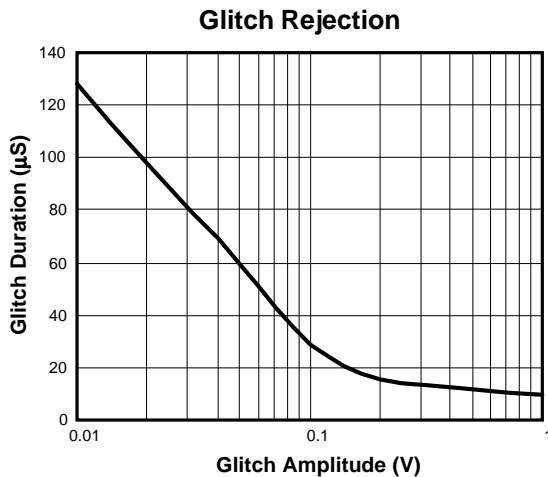



I_{DD} vs. Temperature

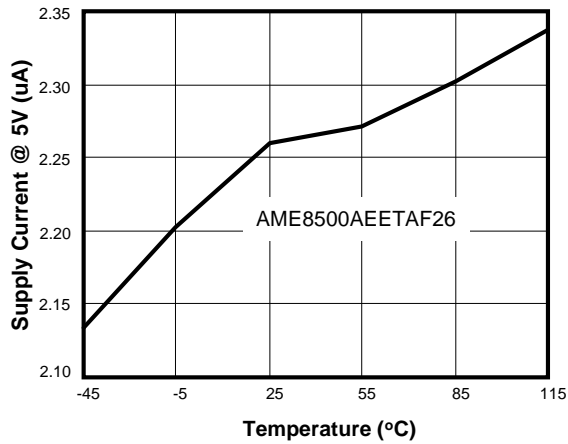

Reset V_{TH} vs. Temperature

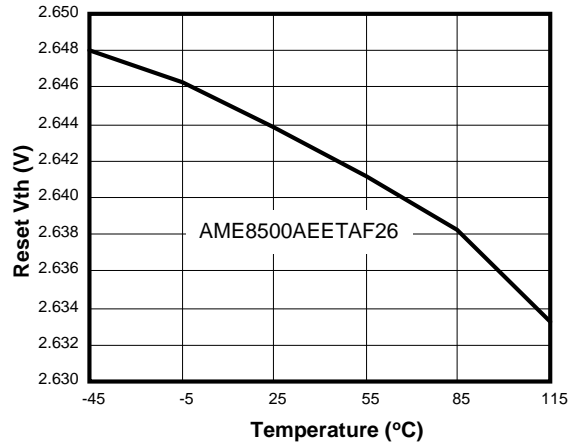

I_{DD} vs. V_{DD}

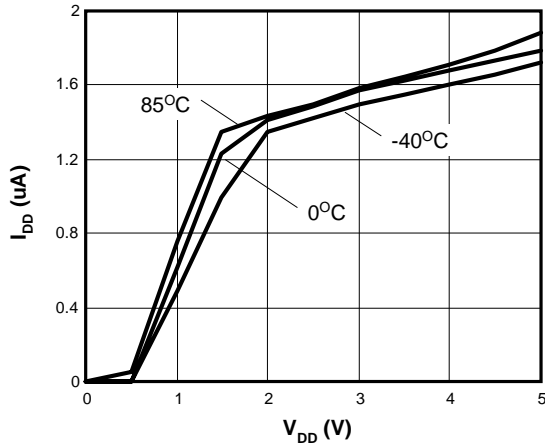

T_{D1} Delay vs. Temperature

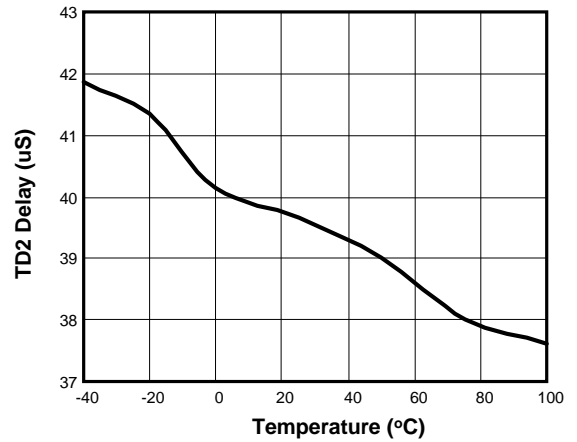

Threshold Hysteresis vs. Temperature

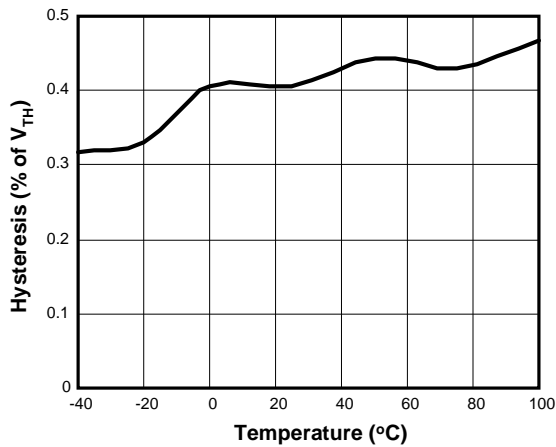

Reset VOL vs. Temperature

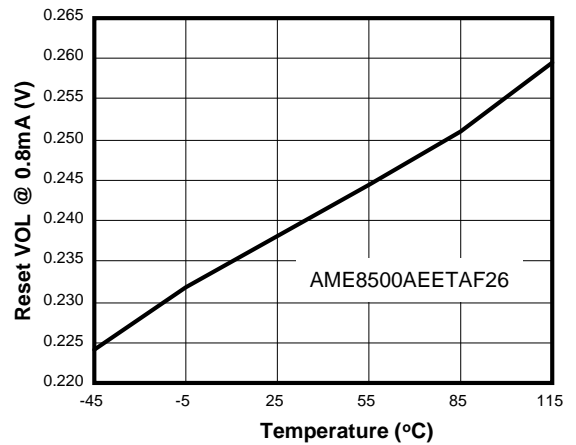

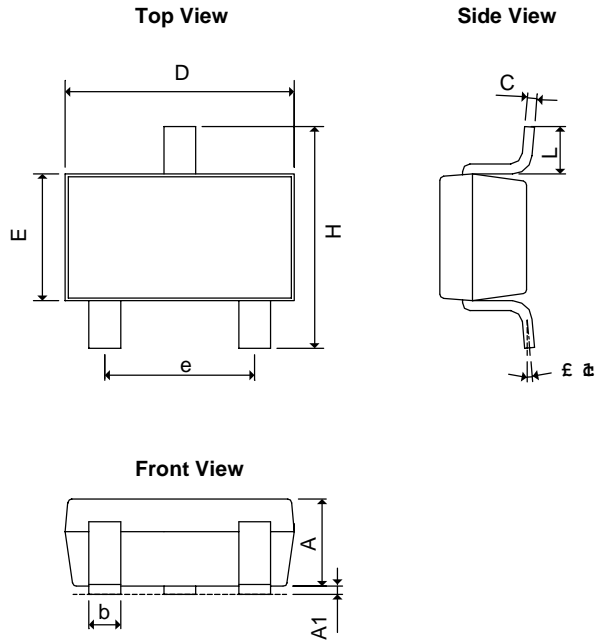
■ Package Dimension
SOT-23

SYMBOLS	MILLIMETERS		INCHES	
	MIN	MAX	MIN	MAX
A	1.00	1.40	0.0394	0.0551
A₁	0.00	0.15	0.0000	0.0059
b	0.35	0.50	0.0138	0.0197
C	0.09	0.25	0.0035	0.0098
D	2.70	3.10	0.1063	0.1220
E	1.40	1.80	0.0551	0.0709
e	1.90 BSC		0.0748 BSC	
H	2.40	3.00	0.09449	0.11811
L	0.35BSC		0.0138BSC	
θ1	0°	10°	0°	10°

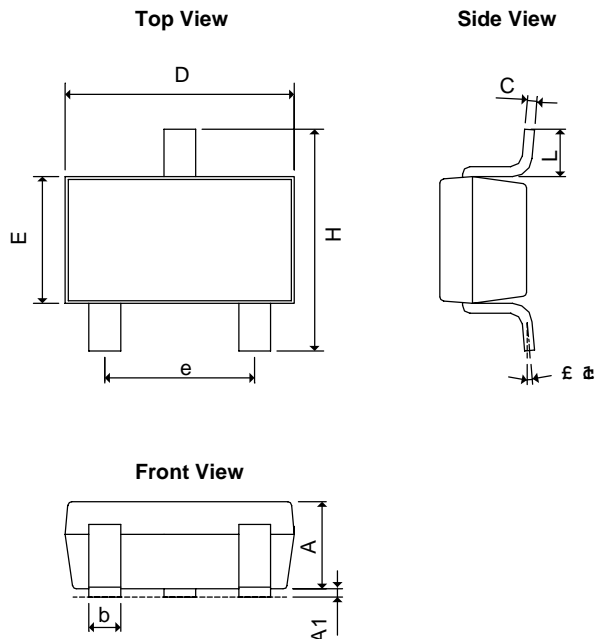
SOT-23-L

SYMBOLS	MILLIMETERS		INCHES	
	MIN	MAX	MIN	MAX
A+A₁	1.00	1.30	0.0394	0.0512
b	0.35	0.50	0.0138	0.0197
C	0.09	0.25	0.0035	0.0098
D	2.70	3.10	0.1063	0.1220
E	1.40	1.80	0.0551	0.0709
e	1.90 BSC		0.0748 BSC	
H	2.40	3.00	0.09449	0.11811
L	0.35BSC		0.0138BSC	
θ1	0°	10°	0°	10°



■ Package Dimension

SOT-89

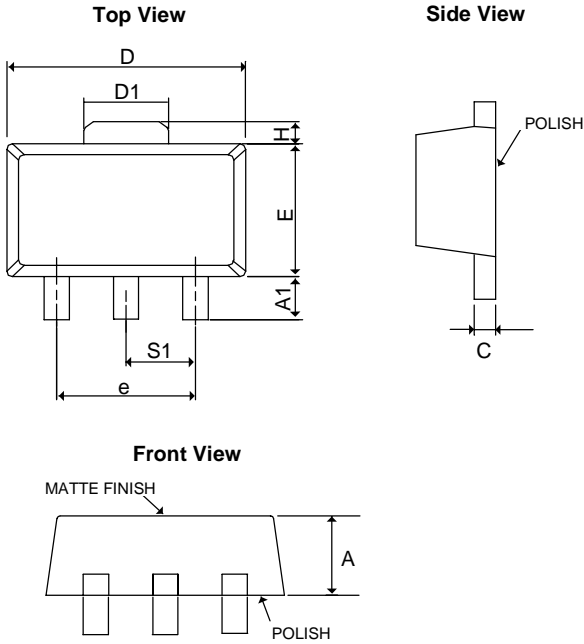

SYMBOLS	MILLIMETERS		INCHES	
	MIN	MAX	MIN	MAX
A	1.39	1.60	0.05472	0.06299
A ₁	0.8REF		0.0315REF	
C	0.35	0.44	0.01378	0.01732
D	4.39	4.60	0.17283	0.1811
D ₁	1.35	1.83	0.05315	0.07205
E	2.28	3.60	0.08976	0.14173
e	3.00REF		0.1181REF	
H	0.70REF		0.0276REF	
S ₁	1.50REF		0.0590REF	

SOT-25

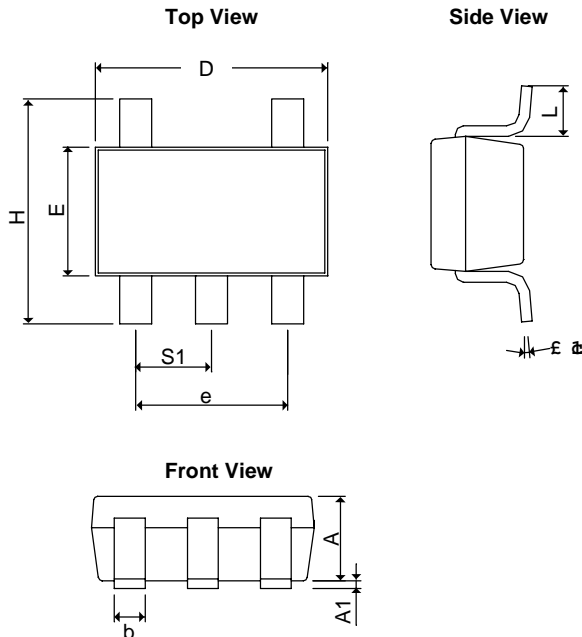

SYMBOLS	MILLIMETERS		INCHES	
	MIN	MAX	MIN	MAX
A	1.20REF		0.0472REF	
A ₁	0.00	0.15	0.0000	0.0059
b	0.30	0.55	0.0118	0.0217
D	2.70	3.10	0.1063	0.1220
E	1.40	1.80	0.0551	0.0709
e	1.90 BSC		0.07480 BSC	
H	2.60	3.00	0.10236	0.11811
L	0.37BSC		0.0146BSC	
θ ₁	0°	10°	0°	10°
S ₁	0.95BSC		0.0374BSC	



www.ame.com.tw
E-Mail: sales@ame.com.tw

Life Support Policy:

These products of AME, Inc. are not authorized for use as critical components in life-support devices or systems, without the express written approval of the president of AME, Inc.

AME, Inc. reserves the right to make changes in the circuitry and specifications of its devices and advises its customers to obtain the latest version of relevant information.

© AME, Inc. , June 2003

Document: 2007-DS8500/8501-L

Corporate Headquarter
AME, Inc.

2F, 189 Kang-Chien Road, Nei-Hu Dist.
Taipei 114 Taiwan, R.O.C.
Tel: 886 2 2627-8687
Fax: 886 2 2659-2989

U.S.A. Subsidiary
Analog Microelectronics, Inc.

3100 De La Cruz Blvd., Suite 201
Santa Clara, CA. 95054-2046
Tel : (408) 988-2388
Fax: (408) 988-2489



LittleDiode supplies new, hard to find or obsolete electronic components and semiconductors all over the world.

With over two million different components listed you are sure to find the part you need.

Feel free to visit us today at our online store:

LittleDiode.com

Looking forward to providing you with the best possible service.