

CEM9424

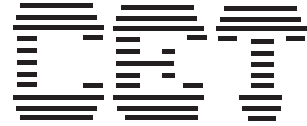

MAY 1999

P-Channel Enhancement Mode Field Effect Transistor

5

FEATURES

- -20V , -7.7A , $R_{DS(ON)}=25m\Omega$ @ $V_{GS}=-4.5V$.
 $R_{DS(ON)}=35m\Omega$ @ $V_{GS}=-2.5V$.
- Super high dense cell design for extremely low $R_{DS(ON)}$.
- High power and current handing capability.
- Surface Mount Package.

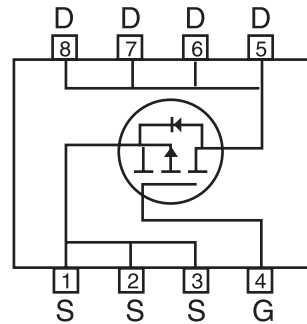
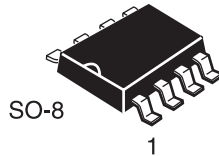

ABSOLUTE MAXIMUM RATINGS ($T_A=25^{\circ}C$ unless otherwise noted)

Parameter	Symbol	Limit	Unit
Drain-Source Voltage	VDS	-20	V
Gate-Source Voltage	VGS	± 8	V
Drain Current-Continuous ^a @ $T_J=125^{\circ}C$ -Pulsed ^b	ID	± 7.7	A
	IDM	± 30	A
Drain-Source Diode Forward Current ^a	IS	-2.3	A
Maximum Power Dissipation ^a	PD	2.5	W
Operating Junction and Storage Temperature Range	TJ, TSTG	-55 to 150	$^{\circ}C$

THERMAL CHARACTERISTICS

Thermal Resistance, Junction-to-Ambient ^a	$R_{\theta JA}$	50	$^{\circ}C/W$
--	-----------------	----	---------------

CEM9424

ELECTRICAL CHARACTERISTICS (T_A=25°C unless otherwise noted)

Parameter	Symbol	Condition	Min	Typ ^c	Max	Unit
OFF CHARACTERISTICS						
Drain-Source Breakdown Voltage	BV _{DSS}	V _{GS} =0V, I _D =-250μA	-20			V
Zero Gate Voltage Drain Current	I _{DSS}	V _{DS} =-12V, V _{GS} =0V			-1	μA
Gate-Body Leakage	I _{GSS}	V _{GS} =±8V, V _{DS} =0V			±100	nA
ON CHARACTERISTICS^b						
Gate Threshold Voltage	V _{GS(th)}	V _{DS} =V _{GS} , I _D =-250μA	-0.6			V
Drain-Source On-State Resistance	R _{DS(ON)}	V _{GS} =-4.5V, I _D =-7.7A		19	25	mΩ
		V _{GS} =-2.5V, I _D =-6.6A		24	35	mΩ
On-State Drain Current	I _{D(ON)}	V _{DS} =-5V, V _{GS} =-4.5V	-30			A
Forward Transconductance	g _{FS}	V _{DS} =-10V, I _D =-7.7A		23		S
DYNAMIC CHARACTERISTICS^c						
Input Capacitance	C _{ISS}	V _{DS} =-10V, V _{GS} =0V f=1.0MHz		2690	3500	pF
Output Capacitance	C _{OSS}			1300	1700	pF
Reverse Transfer Capacitance	C _{RSS}			615	800	pF
SWITCHING CHARACTERISTICS^c						
Turn-On Delay Time	t _{D(ON)}	V _{DD} =-6V I _D =-1A, V _{GEN} =-4.5V, R _{GEN} =6Ω		60	80	ns
Rise Time	t _r			90	130	ns
Turn-Off Delay Time	t _{D(OFF)}			310	400	ns
Fall Time	t _f			190	250	ns
Total Gate Charge	Q _g	V _{DS} =-6V, I _D =-7.7A, V _{GS} =-4.5V		46	80	nC
Gate-Source Charge	Q _{gs}			6		nC
Gate-Drain Charge	Q _{gd}			13		nC

CEM9424

ELECTRICAL CHARACTERISTICS (T_A=25°C unless otherwise noted)

5

Parameter	Symbol	Condition	Min	Typ ^c	Max	Unit
DRAIN-SOURCE DIODE CHARACTERISTICS^b						
Diode Forward Voltage	V _{SD}	V _{GS} = 0V, I _S = -2.3A		-0.7	-1.2	V

- Notes
- a. Surface Mounted on FR4 Board, t ≤ 10sec.
 - b. Pulse Test: Pulse Width ≤ 300 μs, Duty Cycle ≤ 2%.
 - c. Guaranteed by design, not subject to production testing.

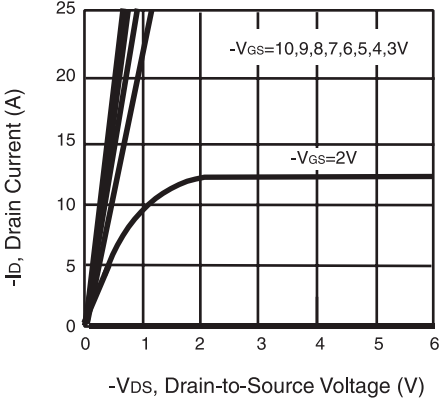

Figure 1. Output Characteristics

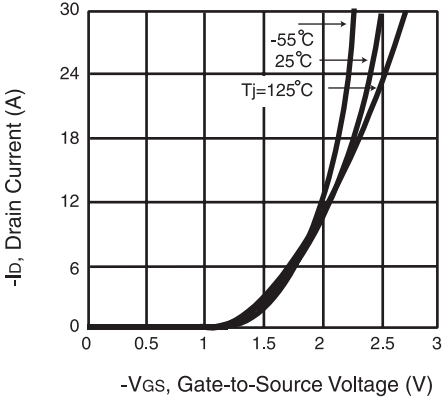

Figure 2. Transfer Characteristics

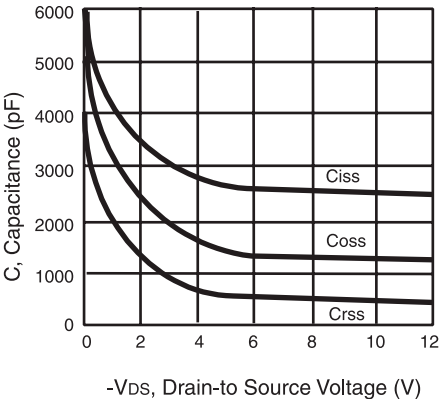

Figure 3. Capacitance

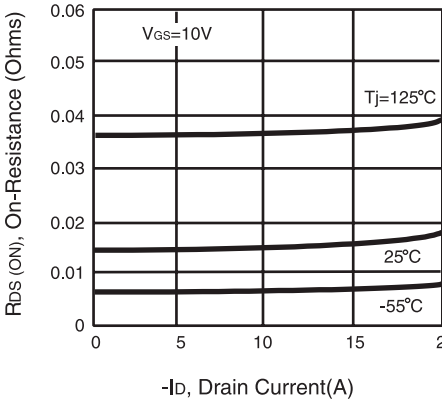

Figure 4. On-Resistance Variation with Drain Current and Temperature

CEM9424

5

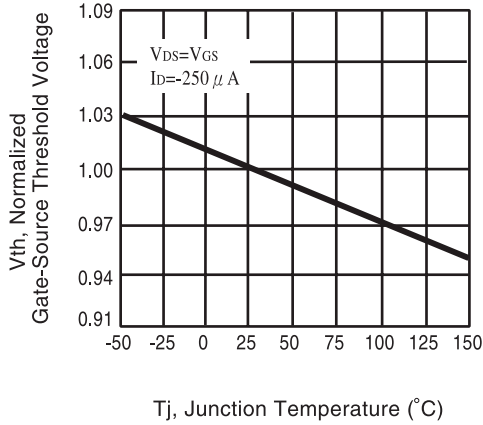

Figure 5. Gate Threshold Variation with Temperature

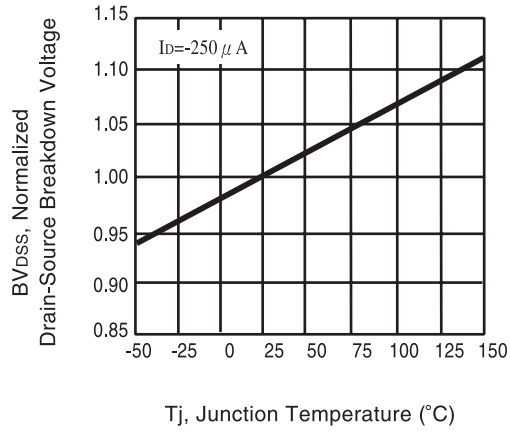

Figure 6. Breakdown Voltage Variation with Temperature

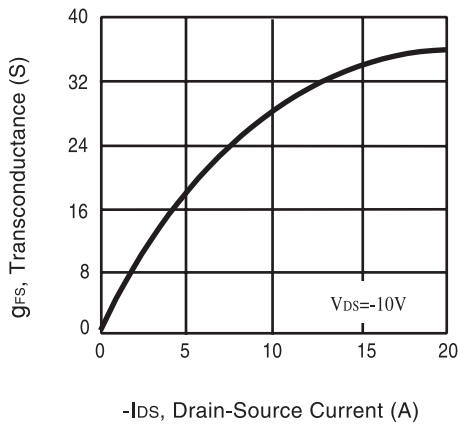

Figure 7. Transconductance Variation with Drain Current

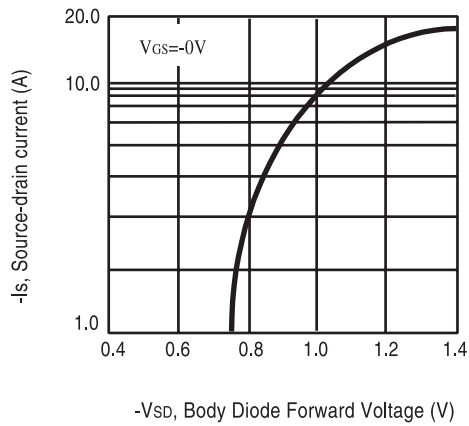

Figure 8. Body Diode Forward Voltage Variation with Source Current

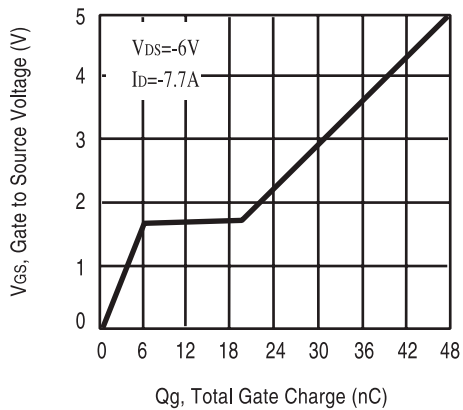

Figure 9. Gate Charge

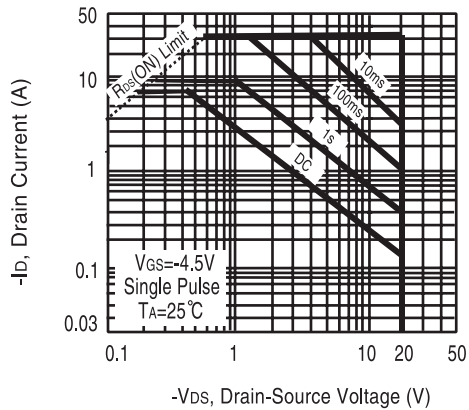

Figure 10. Maximum Safe Operating Area

CEM9424

5

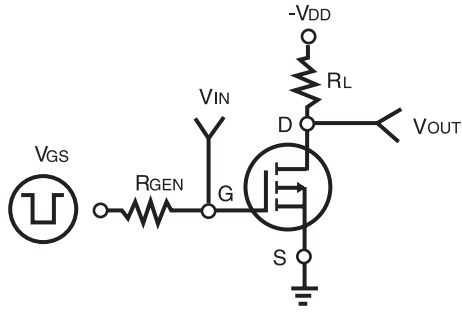

Figure 11. Switching Test Circuit

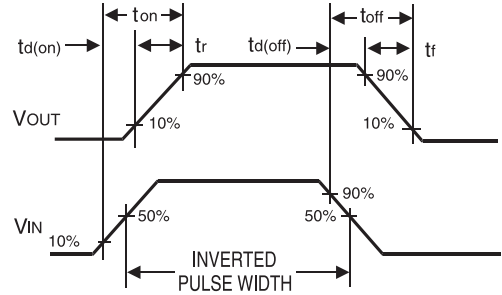

Figure 12. Switching Waveforms

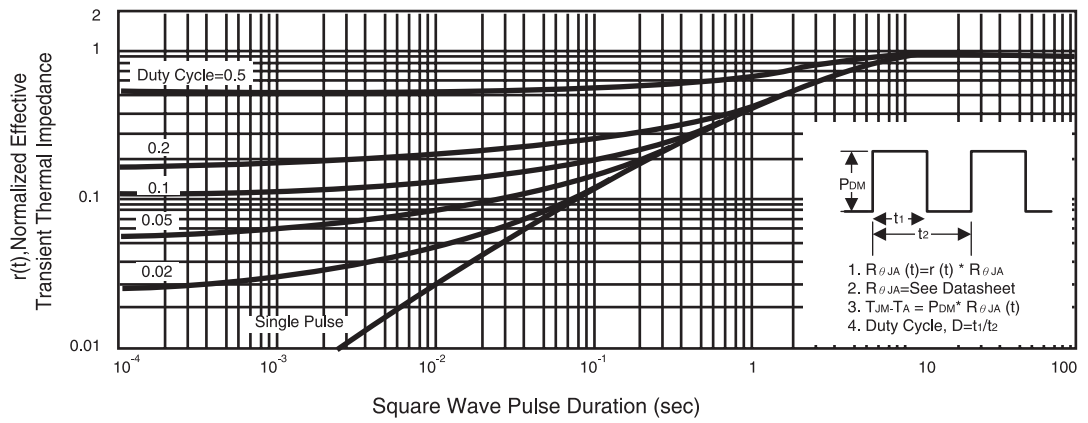

Figure 13. Normalized Thermal Transient Impedance Curve



LittleDiode supplies new, hard to find or obsolete electronic components and semiconductors all over the world.

With over two million different components listed you are sure to find the part you need.

Feel free to visit us today at our online store:

LittleDiode.com

Looking forward to providing you with the best possible service.