

CGS2535V Commercial Quad 1 to 4 Clock Drivers

CGS2535TV Industrial Quad 1 to 4 Clock Drivers

General Description

These Clock Generation and Support clock drivers are specifically designed for driving memory arrays requiring large fanouts while operating at high speeds.

This device meets the rise and fall time requirements of the 90 and 100 MHz Pentium™ processors.

The CGS2535 is a non-inverting 4 to 16 driver with CMOS I/O structures. The CGS2535 specification guarantees part-to-part skew variation.

Features

- Guaranteed:
 - 1.0 ns rise and fall times while driving 12 inches of 50Ω microstrip terminated with 25 pF
 - 350 ps pin-to-pin skew (t_{OSLH} and t_{OSHL})

- 650 ps part-to-part variation on positive or negative transition
- Operates with either 3.3V or 5.0V supply
- Inputs 5V tolerant with V_{CC} in 3.3V range
- Symmetric output current drive: 24 mA I_{OH}/I_{OL}
- Industrial temperature range -40°C to +85°C
- Symmetric package orientation
- Large fanout for memory driving applications
- Guaranteed 2 kV ESD protection
- Implemented on National's ABT family process
- 28-pin PLCC for optimum skew performance

Connection Diagrams

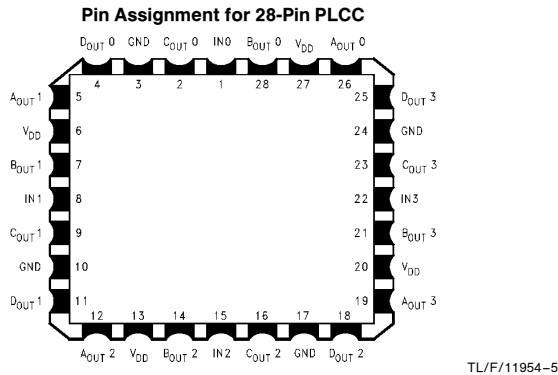

Truth Table

Input	Output
In (0-3)	ABCD Out (0-3)

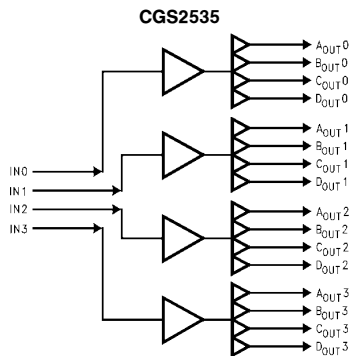

Pentium™ is a trademark of Intel Corporation.

Absolute Maximum Ratings (Note)

If Military/Aerospace specified devices are required, please contact the National Semiconductor Sales Office/Distributors for availability and specifications.

Supply Voltage (V_{CC})	7.0V
Input Voltage (V_i)	7.0V
Input Current	-30 mA
Current Applied to Output (High/Low)	Twice the Rated I_{OH}/I_{OL}
Operating Temp. Industrial grade	-40°C to +85°C
Comm. grade	0°C to +70°C
Storage Temperature Range	-65°C to +150°C
Airflow	Typical θ_{JA}
0 LFM	62°C/W
225 LFM	43°C/W
500 LFM	34°C/W
900 LFM	27°C/W

Recommended Operating Conditions

Supply Voltage	V_{CC} 4.5V to 5.5V
	V_{CC} 3.0V to 3.6V
Maximum Input Rise/Fall Time (0.8V to 2.0V)	5 ns
Free Air Operating Temperature	
Commercial	0°C to +70°C
Industrial	-40°C to +85°C

Note: The Absolute Maximum Ratings are those values beyond which the safety of the device cannot be guaranteed. The device should not be operated at these limits. The parametric values defined in the DC and AC Electrical Characteristics tables are not guaranteed at the absolute maximum ratings. The Recommended Operating Conditions will define the conditions for actual device operation.

DC Electrical Characteristics

Over recommended operating free air temperature range. All typical values are measured at $V_{CC} = 5V$, $T_A = 25^\circ C$.

Symbol	Parameter	Conditions	V_{CC} (V)	Min	Typ	Max	Units
V_{IH}	Input High Level Voltage		3.0	2.1			V
			4.5	3.15			
			5.5	3.85			
V_{IL}	Input Low Level Voltage		3.0			0.9	V
			4.5			1.35	
			5.5			1.65	
V_{IK}	Input Clamp Voltage	$I_i = -18$ mA	4.5			-1.2	V
V_{OH}	High Level Output Voltage	$I_{OH} = -50$ μA	3.0	2.9			V
			4.5	4.4			
			5.5	5.4			
		$I_{OH} = -24$ mA	3.0	2.46			V
			4.5	3.76			
			5.5	4.76			
V_{OL}	Low Level Output Voltage	$I_{OL} = 50$ μA	3.0			0.1	V
			4.5			0.1	
			5.5			0.1	
		$I_{OL} = 24$ mA	3.0			0.44	V
			4.5			0.44	
			5.5			0.44	
I_i	Input Current @ Max Input Voltage	$V_{IH} = 7V$	5.5			7	μA
		$V_{IH} = V_{CC}$	3.6			1	
I_{IH}	High Level Input Current	$V_{IH} = V_{CC}$	5.5			5	μA
I_{IL}	Low Level Input Current	$V_{IL} = 0V$	5.5	-5			μA
I_{OLD}	Minimum Dynamic Output Current*	$V_{OLD} = 1.65V$ (max)	5.5	75			mA
		$V_{OLD} = 0.9V$ (max)	3.0**	36			
I_{OHD}	Minimum Dynamic Output Current*	$V_{OHD} = 3.85V$ (min)	5.5	-75			mA
		$V_{OHD} = 2.1V$ (min)	3.0**	-25			
I_{CC}	Supply Current		3.6			75	μA
			5.5			235	
C_{IN}	Input Capacitance		5.0		5		pF

*Maximum test duration 2.0 ms, one output loaded at a time.

**At $V_{CC} = 3.3V$, $I_{OLD} = 55$ mA min; @ $V_{CC} = 3.6V$, $I_{OLD} = 64$ mA min
At $V_{CC} = 3.3V$, $I_{OHD} = -58$ mA min; @ $V_{CC} = 3.6V$, $I_{OHD} = -66$ mA min

AC Electrical Characteristics (Notes 1, 2, and 3)

Over recommended operating free air temperature specified. All typical values are measured at $V_{CC} = 5V$, $T_A = 25^\circ C$.

Symbol	Parameter	V _{CC} (V) (Note 8)	CGS2535						Units
			T _A = +25°C C _L = 50 pF, R _L = 500Ω			T _A = -40°C to +85°C (Note 4) C _L = 50 pF, R _L = 500Ω			
			Min	Typ	Max	Min	Typ	Max	
f _{max}	Frequency Maximum	3.0 5.0					100 125		MHz
t _{PLH}	Low-to-High Propagation Delay CK to O _n	3.3 5.0			4.5 3.5			4.5 3.5	ns
t _{PHL}	High-to-Low Propagation Delay CK to O _n	3.3 5.0			4.5 3.5			4.5 3.5	ns
t _{OSLH}	Maximum Skew Common Edge Output-to-Output Variation (Notes 1, 3)	3.3 5.0		150 150	350 350		300 300	350 350	ps
t _{OSHL}	Maximum Skew Common Edge Output-to-Output Variation (Notes 1, 3)	3.3 5.0		150 150	350 350		300 300	350 350	ps
t _{rise} , t _{fall}	Rise/Fall Time (from 0.8V/2.0V to 2.0V/0.8V) (Note 5)	3.3 5.0			3.5 3.0			3.5 3.0	ns
t _{rise} , t _{fall}	Rise/Fall Time (from 0.8V/2.0V to 2.0V/0.8V) (Note 6)	3.3 5.0			0.8 0.4			1.0 0.6	ns
t _{rise} , t _{fall}	Rise/Fall Time (from 0.8V/2.0V to 2.0V/0.8V) (Note 7)	3.3 5.0			1.0 0.7			1.0 0.9	ns
t _{High}	Pulse Width Duration High (Notes 2, 3)	3.3 5.0	4.0 4.0			4.0 4.0			ns
t _{Low}	Pulse Width Duration Low (Notes 2, 3)	3.3 5.0	4.0 4.0			4.0 4.0			
t _{PVLH}	Part-to-Part Variation of Low-to-High Transitions	3.3 5.0			650 650			650 650	ps
t _{PVHL}	Part-to-Part Variation of High-to-Low Transitions	3.3 5.0			650 650			650 650	

Note 1: Output-to-Output Skew is defined as the absolute value of the difference between the actual propagation delay for any outputs within the same packaged device. The specifications apply to any outputs switching in the same direction either LOW to HIGH (t_{OSLH}) or HIGH to LOW (t_{OSHL}).

Note 2: Time high is measured with outputs at 2.0V or above. Time low is measured with outputs at 0.8V or below. Input waveform characteristics for t_{High}, t_{Low} measurement: f = 66.67 MHz, duty cycle = 50%.

Note 3: The input waveform has a rise and fall time transition time of 2.5 ns (10% to 90%).

Note 4: Industrial range (-40°C to +85°C) limits apply to the commercial temperature range (0°C to +70°C).

Note 5: These Rise and Fall times are measured with C_L = 50 pF, R_L = 500Ω (see Figure 1).

Note 6: These Rise and Fall times are measured with C_L = 25 pF, R_L = 500Ω (see Figure 1), and are guaranteed by design.

Note 7: These Rise and Fall times are measured driving 12 inches of 50Ω microstrip terminated with equivalent C_L = 25 pF (see Figure 2), and are guaranteed by design.

Note 8: Voltage Range 5.0 is 5.0V ± 0.5V, 3.3 is 3.3V ± 0.3V.

Note 9: For increased output drive, output pins may be connected together when the corresponding input pins are connected together.

Timing Information

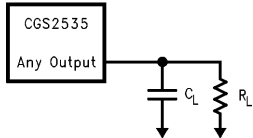
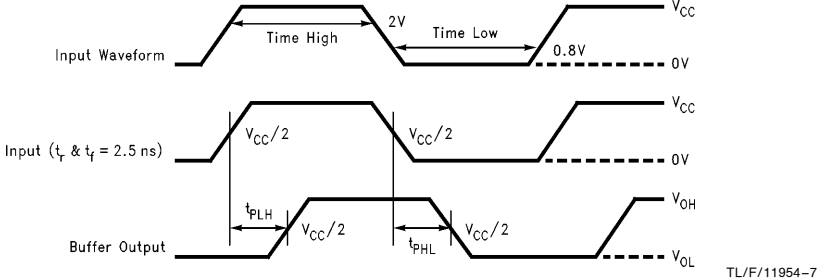

FIGURE 1. A.C. Load (Reference Notes 5, 6)
 C_L = Total Load Including Probes

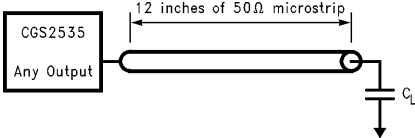

FIGURE 2. A.C. Load (Reference Note 7)
 C_L = Total Load Including Probes

CGS2534/35/36/37

Memory Array Driving

In order to minimize the total load on the address bus, quite often memory arrays are driven by buffers while having the inputs of the buffers tied together. Although this practice was feasible in the conventional memory designs, in today's high speed, large buswidth designs which require address fetching at higher speeds, this technique produces many undesired results such as cross-talk and over/undershoot. CGS2534/35/36/37 Quad 1 to 4 clock drivers were designed specifically to address these application issues on high speed, large memory arrays systems.

These drivers are optimized to drive large loads, with 3.5 ns propagation delays. These drivers produce less noise while reducing the total capacitive loading on the address bus by having only four inputs tied together (see the diagram below, point A). This helps to minimize the overshoot and undershoot by having only four outputs being switched simultaneously.

Also this larger fan-out helps to save board space since for every one of these drivers, two conventional buffers were typically being used.

Another feature associated with these clock drivers is a 350 ps pin-to-pin skew specification. The minimum skew specification allows high speed memory system designers to optimize the performance of their memory sub-system by operating at higher frequencies without having concerns about output-to-output (bank-to-bank) synchronization problems which are associated with driving high capacitive loads (Point B).

The diagram below depicts a "2534/35/36/37" a memory subsystem operating at high speed with large memory capacity. The address bus is common to both the memory and the CPU and I/Os.

These drivers can operate beyond 125 MHz, and are also available in 3V-5V TTL/CMOS versions with large current drive .

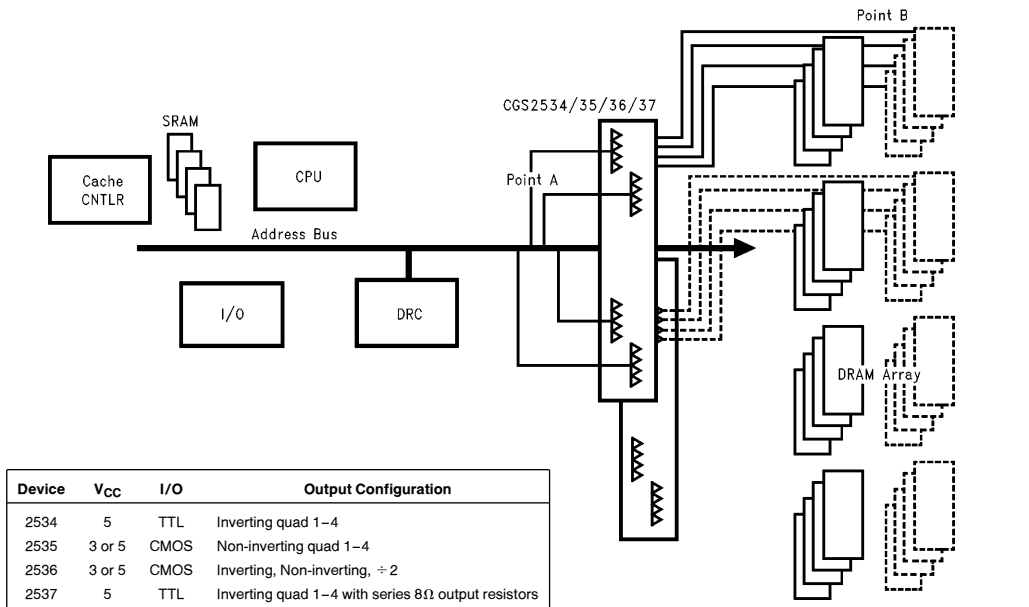

TL/F/11954-8

Ordering Information (Contact NSC Marketing for specific date of availability)



Physical Dimensions inches (millimeters)

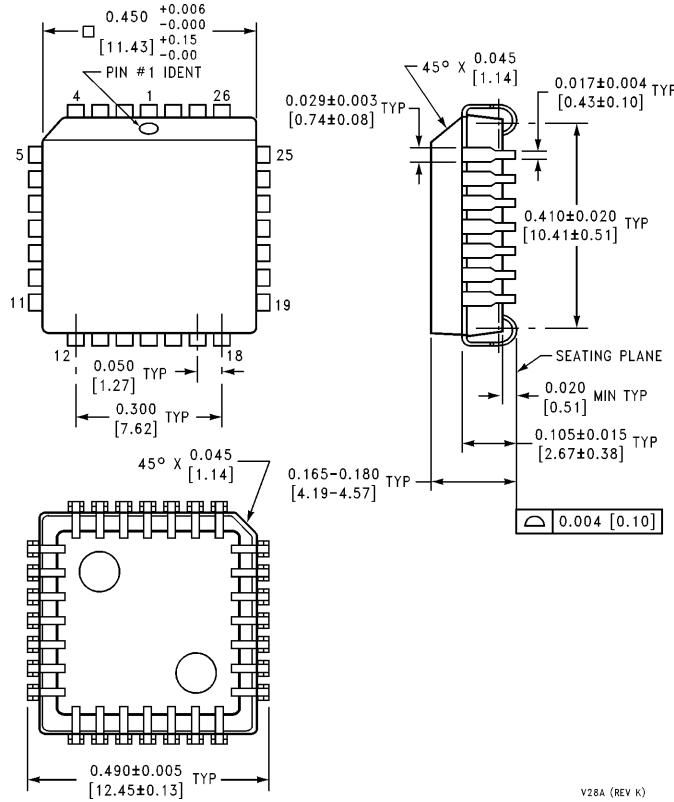

28-Lead Molded Plastic Leaded Chip Carrier
Order Number CGS2535V or CGS2535TV
NS Package Number V28A

V28A (REV K)

LIFE SUPPORT POLICY

NATIONAL'S PRODUCTS ARE NOT AUTHORIZED FOR USE AS CRITICAL COMPONENTS IN LIFE SUPPORT DEVICES OR SYSTEMS WITHOUT THE EXPRESS WRITTEN APPROVAL OF THE PRESIDENT OF NATIONAL SEMICONDUCTOR CORPORATION. As used herein:

1. Life support devices or systems are devices or systems which, (a) are intended for surgical implant into the body, or (b) support or sustain life, and whose failure to perform, when properly used in accordance with instructions for use provided in the labeling, can be reasonably expected to result in a significant injury to the user.
2. A critical component is any component of a life support device or system whose failure to perform can be reasonably expected to cause the failure of the life support device or system, or to affect its safety or effectiveness.



National Semiconductor Corporation
 1111 West Bardin Road
 Arlington, TX 76017
 Tel: 1(800) 272-9959
 Fax: 1(800) 737-7018

National Semiconductor Europe
 Fax: (+49) 0-180-530 85 86
 Email: onjwge@tevm2.nsc.com
 Deutsch Tel: (+49) 0-180-530 85 85
 English Tel: (+49) 0-180-532 78 32
 Français Tel: (+49) 0-180-532 93 58
 Italiano Tel: (+49) 0-180-534 16 80

National Semiconductor Hong Kong Ltd.
 19th Floor, Straight Block,
 Ocean Centre, 5 Canton Rd.
 Tsimshatsui, Kowloon
 Hong Kong
 Tel: (852) 2737-1600
 Fax: (852) 2736-9960

National Semiconductor Japan Ltd.
 Tel: 81-043-299-2309
 Fax: 81-043-299-2408

National does not assume any responsibility for use of any circuitry described, no circuit patent licenses are implied and National reserves the right at any time without notice to change said circuitry and specifications.

National Semiconductor was acquired by Texas Instruments.

http://www.ti.com/corp/docs/investor_relations/pr_09_23_2011_national_semiconductor.html

This file is the datasheet for the following electronic components:

CGS2535V - <http://www.ti.com/product/cgs2535v?HQS=TI-null-null-dscatalog-df-pf-null-ww>

CGS2535TV - <http://www.ti.com/product/cgs2535tv?HQS=TI-null-null-dscatalog-df-pf-null-ww>



LittleDiode supplies new, hard to find or obsolete electronic components and semiconductors all over the world.

With over two million different components listed you are sure to find the part you need.

Feel free to visit us today at our online store:

LittleDiode.com

Looking forward to providing you with the best possible service.